

### 3AL82038AA-C

Alcatel-Lucent Nokia® 3AL82038AA Compatible TAA Compliant 10GBase-DWDM SFP+ Transceiver (SMF, Tunable, 40km, LC, DOM)

#### Features:

- SFF-8432 and SFF-8472 Compliance
- Duplex LC Connector
- Single-mode Fiber
- Commercial Temperature 0 to 70 Celsius
- Hot Pluggable
- Metal with Lower EMI
- Excellent ESD Protection
- RoHS Compliant and Lead Free



#### Applications:

- 10x Gigabit Ethernet over DWDM
- 8x/10x Fibre Channel
- Access, Metro and Enterprise

#### Product Description

This Alcatel-Lucent Nokia® 3AL82038AA compatible SFP+ transceiver provides 10GBase-DWDM throughput up to 40km over single-mode fiber (SMF) using a tunable wavelength via an LC connector. It is guaranteed to be 100% compatible with the equivalent Alcatel-Lucent Nokia® transceiver. This easy to install, hot swappable transceiver has been programmed, uniquely serialized and data-traffic and application tested to ensure that it will initialize and perform identically. Digital optical monitoring (DOM) support is also present to allow access to real-time operating parameters. This transceiver is Trade Agreements Act (TAA) compliant. We stand behind the quality of our products and proudly offer a limited lifetime warranty.

ProLabs's transceivers are RoHS compliant and lead-free.

TAA refers to the Trade Agreements Act (19 U.S.C. & 2501-2581), which is intended to foster fair and open international trade. TAA requires that the U.S. Government may acquire only "U.S. – made or designated country end products."



## Regulatory Compliance

- ESD to the Electrical PINs: compatible with MIL-STD-883E Method 3015.4
- ESD to the LC Receptacle: compatible with IEC 61000-4-3
- EMI/EMC compatible with FCC Part 15 Subpart B Rules, EN55022:2010
- Laser Eye Safety compatible with FDA 21CFR, EN60950-1& EN (IEC) 60825-1,2
- RoHS compliant with EU RoHS 2.0 directive 2015/863/EU

## 100GHz Duplex Full Band Auto-Tune Channel Map

Channel	Frequency (THz)	Wavelength (nm)	Channel	Frequency (THz)	Wavelength (nm)
14	191.4	1566.31	38	193.8	1546.92
15	191.5	1565.5	39	193.9	1546.12
16	191.6	1564.68	40	194.0	1545.32
17	191.7	1563.86	41	194.1	1544.53
18	191.8	1563.05	42	194.2	1543.73
19	191.9	1562.23	43	194.3	1542.94
20	192.0	1561.42	44	194.4	1542.14
21	192.1	1560.61	45	194.5	1541.35
22	192.2	1559.79	46	194.6	1540.56
23	192.3	1558.98	47	194.7	1539.77
24	192.4	1558.17	48	194.8	1538.98
25	192.5	1557.36	49	194.9	1538.19
26	192.6	1556.55	50	195.0	1537.4
27	192.7	1555.75	51	195.1	1536.61
28	192.8	1554.94	52	195.2	1535.82
29	192.9	1554.13	53	195.3	1535.04
30	193.0	1553.33	54	195.4	1534.25
31	193.1	1552.52	55	195.5	1533.47
32	193.2	1551.72	56	195.6	1532.68
33	193.3	1550.92	57	195.7	1531.9
34	193.4	1550.12	58	195.8	1531.12
35	193.5	1549.32	59	195.9	1530.33
36	193.6	1548.51	60	196.0	1529.55
37	193.7	1547.72	61	196.1	1528.77

### Absolute Maximum Ratings

Parameter	Symbol	Min.	Max.	Unit	Notes
Maximum Supply Voltage	VCCT	0	+3.6	V	+3.3V
Maximum Supply Voltage	VCCR	0	+3.6	V	+3.3V
Storage Temperature	TS	-40	85	°C	
Operating Case Temperature	Tc	0	70	°C	
Optical Receiver Input	PIMAX		+5	dBm	Average
ESD SFI pins	ESD1		1	kV	HBM
ESD except for SFI pins	ESD2		2	kV	HBM

### Electrical Characteristics

Parameter	Symbol	Min.	Typ.	Max.	Unit	Notes
Supply Voltage	VCCT	3.135	3.300	3.465	V	
Supply Voltage	VCCR	3.135	3.300	3.465	V	
Supply Current	Icc3			0.73	A	
Power Consumption	PDS			2.3	W	
<b>Transmitter Electrical Characteristics at B''</b>						
Eye mask	X1			0.12	UI	1
Eye mask	X2			0.33	UI	1
Eye mask	Y1	95			mV	1
Eye mask	Y2			350	mV	1
<b>Receiver Electrical Characteristics at C'</b>						
Eye mask	X1			0.35	UI	2
Eye mask	Y1	150			mV	2
Eye mask	Y2			425	mV	2

### Notes:

1. Eye mask at B''

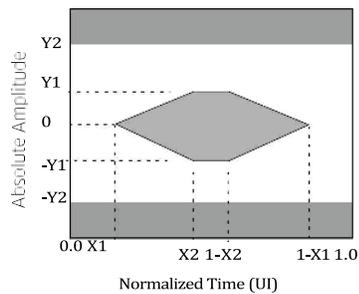

## 2. Eye mask at C'

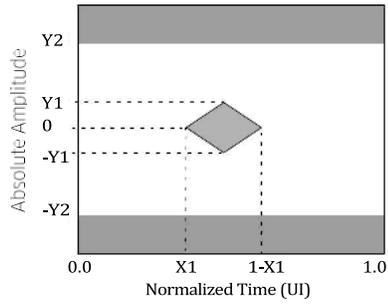

## Inrush Current

Parameter	Symbol	Min.	Max.	Unit	Notes
I <sub>cc</sub> instantaneous peak current			800	mA	1, 2
I <sub>cc</sub> sustained peak current			600	mA	1, 2

### Notes:

1. The maximum currents are the allowed currents for each power supply V<sub>ccT</sub> or V<sub>ccR</sub>, therefore the total module peak currents can be twice this value. The instantaneous peak current is allowed to exceed the specified maximum current capacity of the connector contact for a short period.
2. Not to exceed the sustained peak limit for more than 50 μs; may exceed this limit for shorter durations

## Optical Characteristics

Parameter	Symbol	Min.	Typ.	Max.	Unit	Notes
<b>Transmitter</b>						
Data Rate		1.2		11.3	Gbit/s	NRZ
Optical Extinction Ratio	ER	8.2			dB	1
Side Mode Suppression Ratio	SMSR	35			dB	2
Frequency Range		191.35		196.10	THz	4
Frequency Accuracy		-2.5		+2.5	GHz	EOL
Optical Transmit Power	Po	-1.0		+3.0	dBm	EOL
Shuttered Output power				-35	dBm	
Optical power stability	$\Delta P_o$	-1.0		+1.0	dB	All channels, SOL
Spectral Width (-20dB)	$\Delta\lambda$		0.3	0.5	nm	modulated
Tuning speed				10	sec	5
Mask margin		10			%	
Eye Diagram	GR-253, ITU-T G.691					
<b>Receiver</b>						
Input Operating Wavelength		1525		1575	nm	
Data Rate		1.2		11.3	Gbit/s	NRZ
Minimum Receiver Sensitivity (Back to back)	Prmin			-24	dBm	3
Minimum Receiver Sensitivity (+1100ps/nm)	Prmin			-23	dBm	3
Minimum Receiver Sensitivity (-300 to +1400ps/nm)	Prmin			-21	dBm	3
Maximum input power (overload)	Pro	-7			dBm	3
Receiver Reflectance	RL			-27	dB	
LOS assert		-27.5			dBm	
LOS de-assert				-24	dBm	
LOS Hysteresis		0.1			dB	
LOS assert time				100	us	
LOS de-assert time				100	us	

### Notes:

1. Filtered, 10.3Gb/s
2.  $\pm 2.5$ nm, modulated
3. 10.3Gb/s, 1E-12, OSNR>35dB
4. 50GHz grid, 96 channels
5. Warmed-up, from any CH to any other CH

## Auto Tuning

The auto tuning process is a host independent scheme. When the TSFP+ modules with auto-tuning implemented are inserted into the corresponding electrical ports at a central office and a remote site, both modules will automatically start the automatic tuning process.

The process ensures that the TSFP+ modules tune to the channel defined by the DWDM filter (MUX/DeMUX) which both modules are connected to. The first module to converge on the correct channel initiates a unique process, which helps both sides of the link communicate properly.

After completion of the auto-tune process, both modules fix their wavelengths and move into normal 10 Gbit/s operation. A LOS condition, a shutdown condition (Tx Disable) and a power cycle shall trigger a restart of the auto tuning process.

The TSFP+ module shall appear as a regular Tunable product to the host system once Auto-tune is completed.

## Tuning Parameter

Parameter	Min	Max	Unit	Description
Channel to Channel Switch Time During Tuning		3.256	s	
Tuning Convergence Time		340	s	Not including cold start
Timeout (t1)	400		s	
LOS Timeout (t2)	15	16	s	
Default Channel	191.35		THz	
Channel Sequence	191.35 191.40,...,196.1		THz	50GHz grid
Modulation Rate	125		Baud/s	Manchester encoding
Bit Rate	62.5		Bit/s	

The TSFP+ module shall follow standard MSA behavior according to SFF-8472 and SFF-8690 with the following exceptions:

- During the auto-tune phase, the TSFP+ shall accept host tuning command and restart the auto-scanning from the channel set by host
- When the auto-tune phase is completed and the operational state is reached, the TSFP+ shall accept host tuning commands and set the channel accordingly (just a pure wavelength switch, no message protocol)
- When a loss-of-signal occurs (after a 15s time-out) the TSFP+ shall go back into the auto-tune phase

### SFP+ Module Timing

In the table below figures are shown the required timing for TX\_Fault and TX\_Disable in various conditions. For more detail, please refer to SFF-8431.

Parameter	Symbol	Min.	Max.	Unit	Conditions
TX_disable assert time	t_off		100	μs	1
TX_disable negate time	T_on		2	ms	2
Time to initialize 2-wire interface	t_2w_start_up		300	ms	3
Time to initialize cooled module and time to power up a cooled module to Power Level II	t_start_up_cooled		90	sec	4
Tx_fault assert for cooled module	Tx_fault_on_cooled		1	ms	From occurrence of fault to assertion of TX_Fault
Tx_fault_reset	t_reset	10		μs	Time TX_disable must be held high to reset TX_Fault.
RX_LOS assert delay	t_los_on		100	μs	5
RX_LOS negate delay	t_los_off		100	μs	6

#### Conditions:

1. Rising edge of TX\_disable to fall of output signal below 10% of nominal.
2. Falling edge of TX\_disable to rise of output signal above 90% of nominal. This only applies in normal operation, not during start up or fault recovery.
3. From power on or hot plug after the supply meeting as shown in Electrical Characteristics table.
4. From power supplies meeting as shown in Electrical Characteristics table or hot plug, or Tx disable negated during power up or Tx\_fault recovery, until cooled power level II part during fault recovery is fully operational. Also, from stop bit low-to- high SDA transition enabling power level II until cooled module is fully operational.
5. From occurrence of loss of signal to assertion of RX\_LOS
6. From occurrence of presence of signal to negation of RX\_LOS

## Pin Descriptions

Pin	Symbol	Name/Descriptions	Ref.
1	VeeT	Transmitter Ground (Common with Receiver Ground).	1
2	TX Fault	Transmitter Fault. LVTTTL-O	2
3	TX Disable	Transmitter Disable. Laser output disabled on high or open. LVTTT-I.	3
4	SDA	2-Wire Serial Interface Data Line (Same as MOD-DEF2 in INF-8074i). LVTTTL-I/O.	
5	SCL	2-Wire Serial Interface Data Line (Same as MOD-DEF2 in INF-8074i). LVTTTL-I.	
6	MOD_ABS	Module Absent, Connect to VeeT or VeeR in Module.	4
7	RS0	Rate Select 0. Not used	5
8	LOS	Loss of Signal indication. Logic 0 indicates normal operation. LVTTTL-O.	2
9	RS1	Rate Select 1. Not used	5
10	VeeR	Receiver Ground (Common with Transmitter Ground).	1
11	VeeR	Receiver Ground (Common with Transmitter Ground).	1
12	RD-	Receiver Inverted DATA out. AC Coupled. CML-O.	
13	RD+	Receiver Non-inverted DATA out. AC Coupled. CML-O.	
14	VeeR	Receiver Ground (Common with Transmitter Ground).	1
15	VccR	Receiver Power Supply.	
16	VccT	Transmitter Power Supply.	
17	VeeT	Transmitter Ground (Common with Receiver Ground).	1
18	TD+	Transmitter Non-Inverted DATA in. AC Coupled. CML-I.	
19	TD-	Transmitter Inverted DATA in. AC Coupled. CML-O.	
20	VeeT	Transmitter Ground (Common with Receiver Ground).	1

### Notes:

1. The module signal ground contacts, VeeR and VeeT, should be isolated from the module case.
2. This contact is an open collector/drain output and should be pulled up to the Vcc\_Host with resistor in the range 4.7KΩ to 10KΩ. Pull ups can be connected to one or several power supplies, however the host board design shall ensure that no module contract has voltage exceeding module VccT/R +0.5.V.
3. Tx\_Disable is an input contact with a 4.7KΩ to 10KΩ pull-up resistor to VccT inside module.
4. Mod\_ABS is connected to VeeT or VeeR in the SFP+ module. The host may pull the contract up to Vcc\_Host with a resistor in the range from 4.7KΩ to 10KΩ. Mod\_ABS is asserted “High” when the SFP+ module is physically absent from a host slot.
5. Internally pulled down per SFF-8431

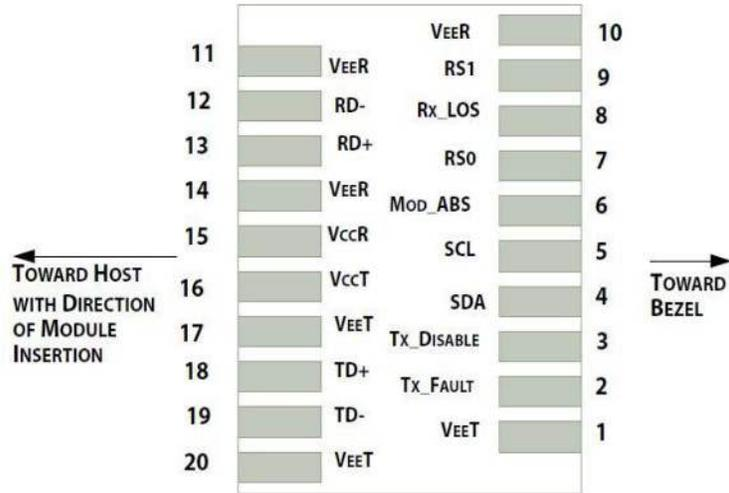

Pin-out of connector Block on Host board

### SFI Data Interface

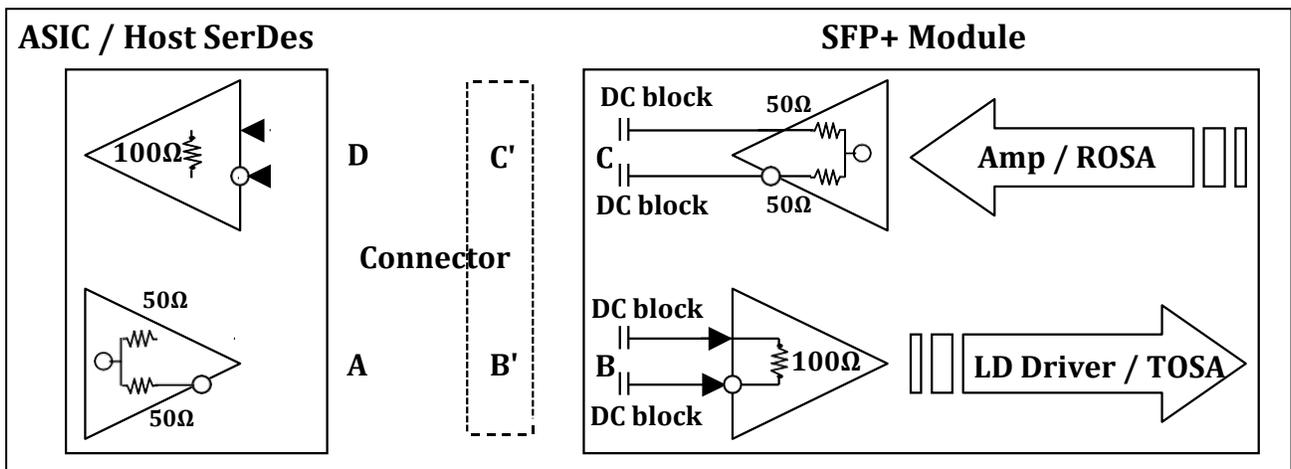

# Block Diagram

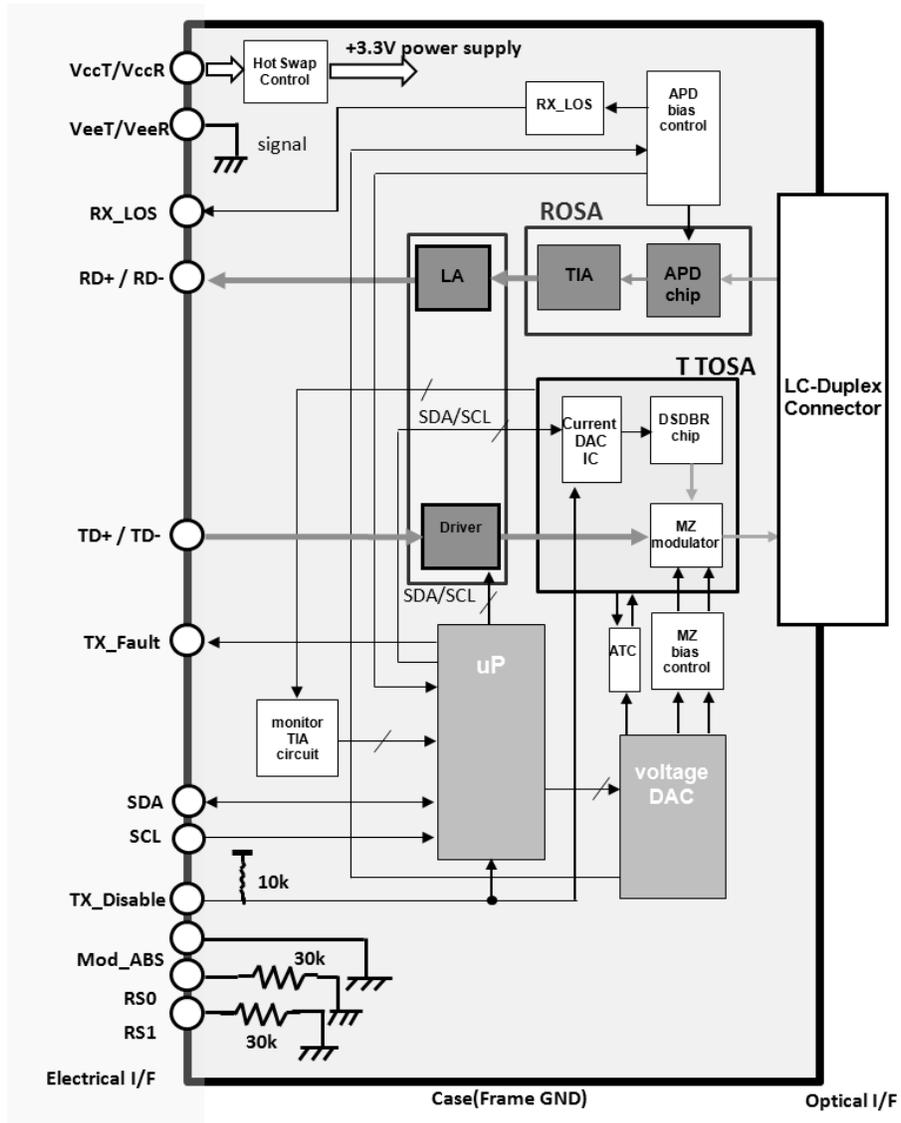

### Mechanical Specifications

Comply to SFF-8432, the improved Pluggable form factor specification, with technique #2 latch. Comply to optional operational mechanical shock test in issue 2 of GR468.

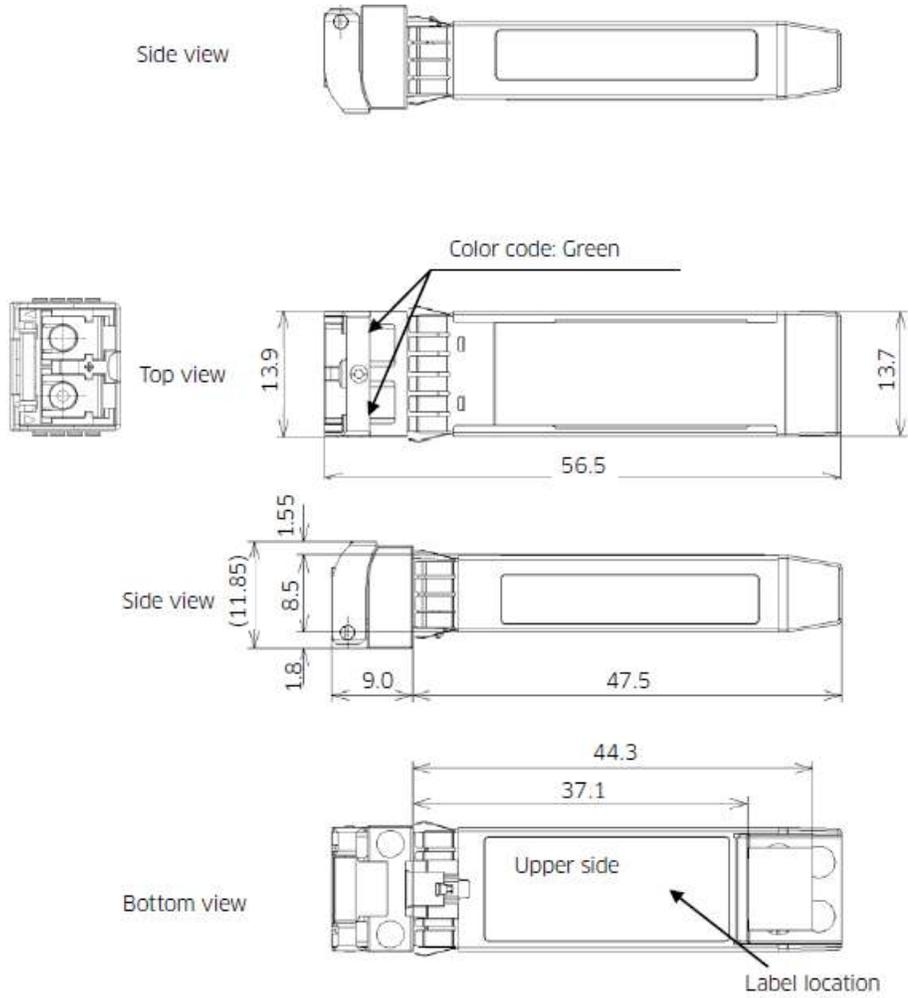

## **About ProLabs**

Our experience comes as standard; for over 15 years ProLabs has delivered optical connectivity solutions that give our customers freedom and choice through our ability to provide seamless interoperability. At the heart of our company is the ability to provide state-of-the-art optical transport and connectivity solutions that are compatible with over 90 optical switching and transport platforms.

## **Complete Portfolio of Network Solutions**

ProLabs is focused on innovations in optical transport and connectivity. The combination of our knowledge of optics and networking equipment enables ProLabs to be your single source for optical transport and connectivity solutions from 100Mb to 400G while providing innovative solutions that increase network efficiency. We provide the optical connectivity expertise that is compatible with and enhances your switching and transport equipment.

## **Trusted Partner**

Customer service is our number one value. ProLabs has invested in people, labs and manufacturing capacity to ensure that you get immediate answers to your questions and compatible product when needed. With Engineering and Manufacturing offices in the U.K. and U.S. augmented by field offices throughout the U.S., U.K. and Asia, ProLabs is able to be our customers best advocate 24 hours a day.

## **Contact Information**

ProLabs US

Email: [sales@prolabs.com](mailto:sales@prolabs.com)

Telephone: 952-852-0252

ProLabs UK

Email: [salessupport@prolabs.com](mailto:salessupport@prolabs.com)

Telephone: +44 1285 719 600