

P	LTR	DESCRIPTION	DATE	DWN	APVD
Y14		PN 3-928836-4 MADE OBSOLETE	23MAR2022	SCB	PS
Z		SYMMETRIC TOLERANCE UPDATE FROM 0.1 TO 0.15	17JUN2023	BGC	KJK

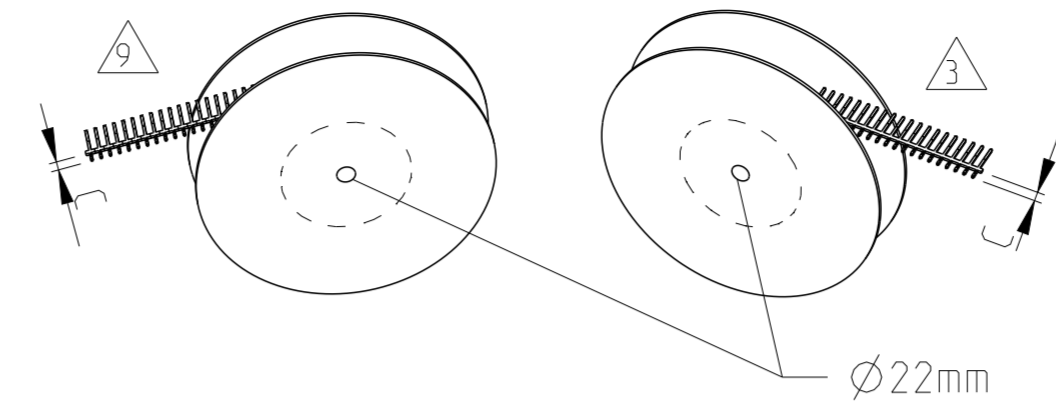

SUR-FACE	A	F	L	N	REV.	REEL MAT.	ORDER NO. (STRIP)	ORDER NO. (LOOSE PIECE)	REEL THICKN.	ENVELOPE CIRCLE
6	6.7	6.7	7.05	11.45	Y		3-928776-2	3-928836-2	30	
13	8.0	8.0	16.8	21.2	A		4-928776-7	-	36	
1	8.0	8.0	16.8	21.2	A		3-928776-7	-	36	
6	8.5	6.0	8.8	13.2	A	21	4-928776-4	-	26	Ø1.13±0.06
10	8.0	-	10.8	15.2	Z		2-928776-3	2-928836-3	30	
1	6.0	5.5	6.25	10.65	Y		5-928776-8	-	30	Ø1.05±0.04
1	6.7	6.7	7.05	11.45	Y		5-928776-6	-	30	
13	8.0	8.0	16.8	21.2	Y		2-928776-7	2-928836-7	44	
1	11.4	11.2	12.4	16.8	Y		2-928776-6	2-928836-6	35	
1	8.5	5.5	8.8	13.2	Y		5-928776-4	5-928836-4	32	
4	4.8	4.8	5.6	10.0	A		3-928776-5	-	30	
6	8.5	6.0	8.8	13.2	Y		3-928776-4	3-928836-4	32	
12	4.8	-	5.6	10.0	Y		2-928776-5	2-928836-5	30	
20	11.4	7.0	12.4	16.8	A		3-928776-6	-	35	
5	6.7	-	7.05	11.45	Y		2-928776-2	2-928836-2	30	
10	19.0	-	20.1	24.5	Y		2-928776-4	2-928836-4	44	
1	6.0	5.5	6.25	10.65	Y		2-928776-0	2-928836-0	30	Ø1.13±0.06
10	4.0	-	4.0	8.4	Y		1-928776-9	1-928836-9	30	
10	6.0	-	8.3	12.7	Y		1-928776-8	1-928836-8	32	
1	8.0	8.0	16.8	21.2	Y		1-928776-7	1-928836-7	44	
10	11.4	-	12.4	16.8	Y		1-928776-6	1-928836-6	35	
19	4.8	4.8	5.6	10.0	Y		1-928776-5	1-928836-5	30	
4	8.5	8.5	8.8	13.2	Y		1-928776-4	1-928836-4	32	
4	8.0	8.0	10.8	15.2	Y		1-928776-3	1-928836-3	35	
1	6.7	6.7	7.05	11.45	Y		1-928776-2	1-928836-2	30	
1	19.0	19.0	20.1	24.5	Y		1-928776-1	1-928836-1	44	

ROUNDED AT AREA A
VERRUNDET IM BEREICH A

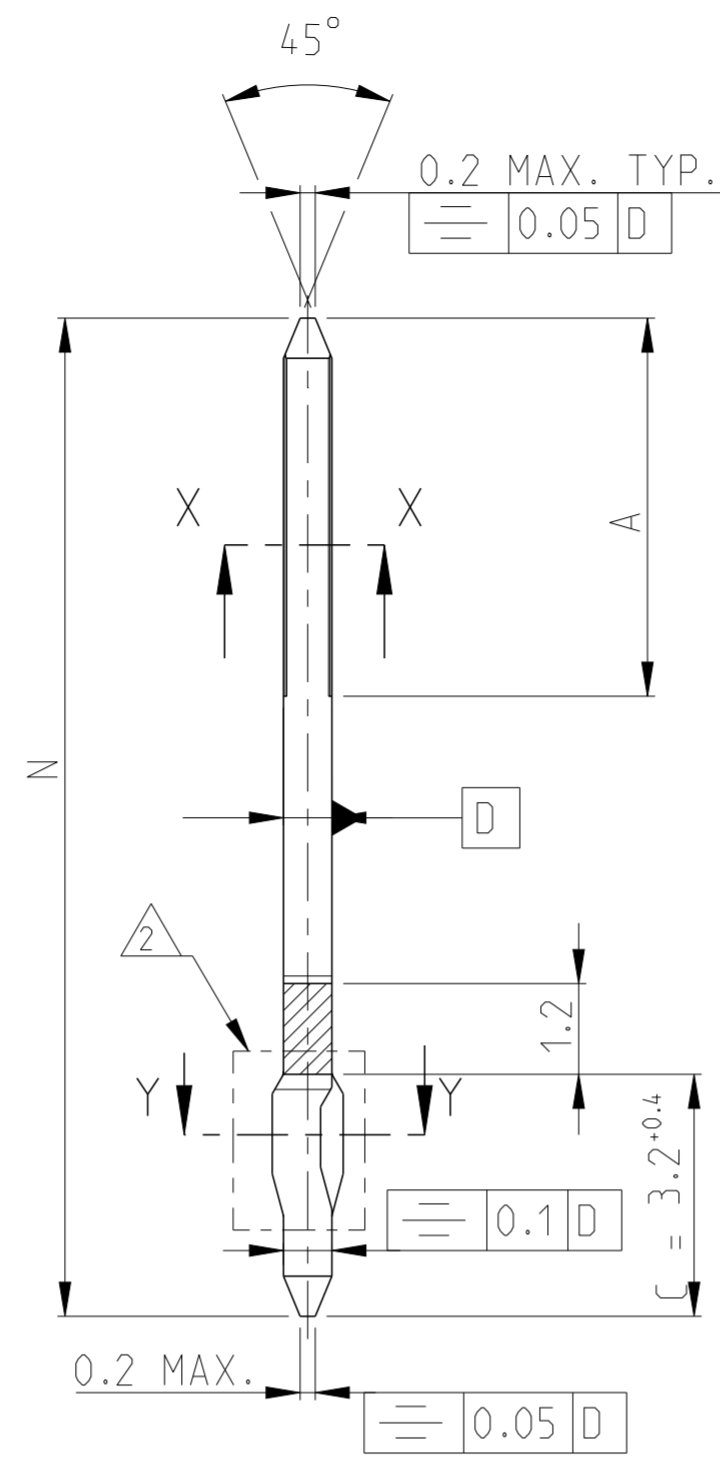
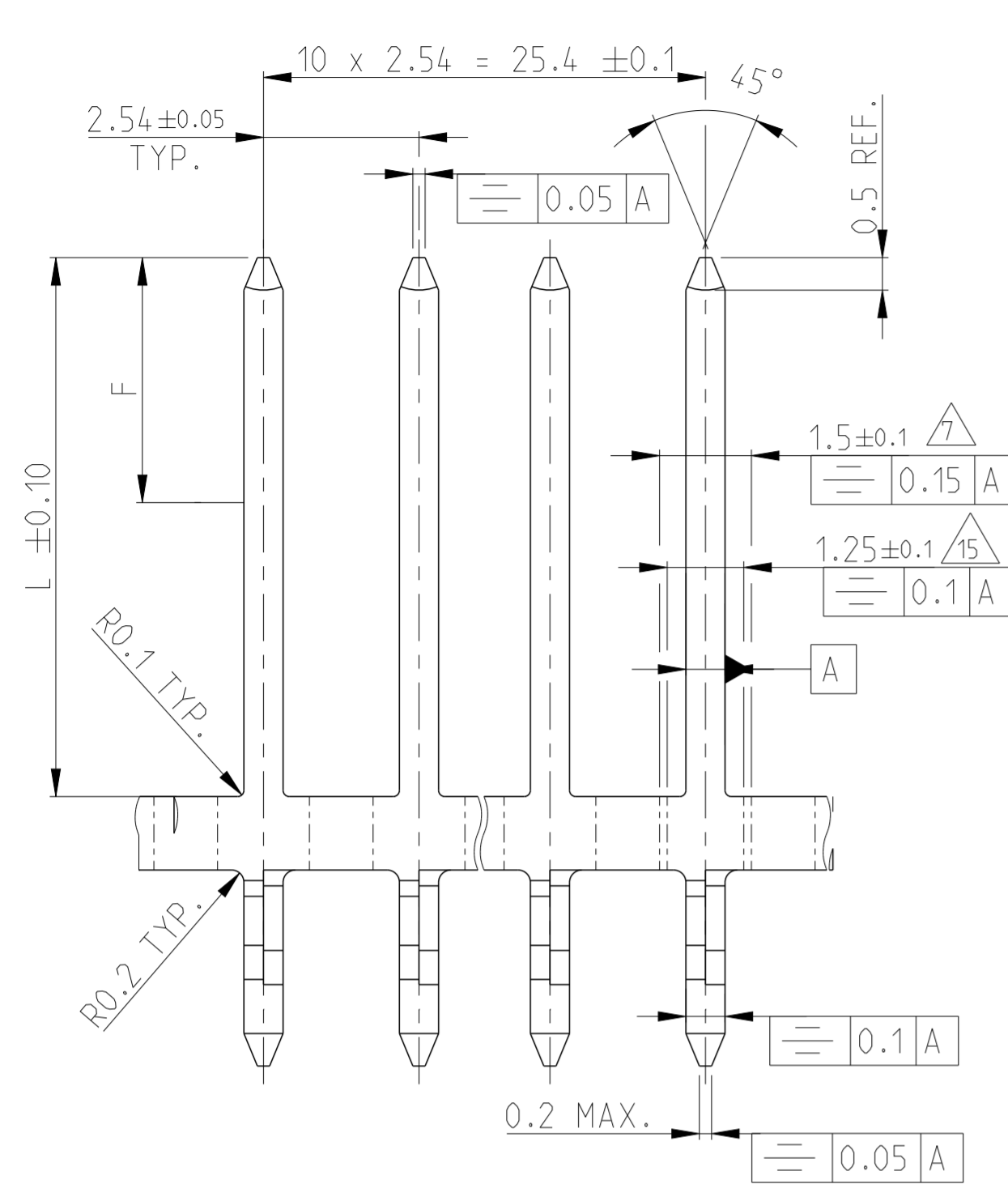
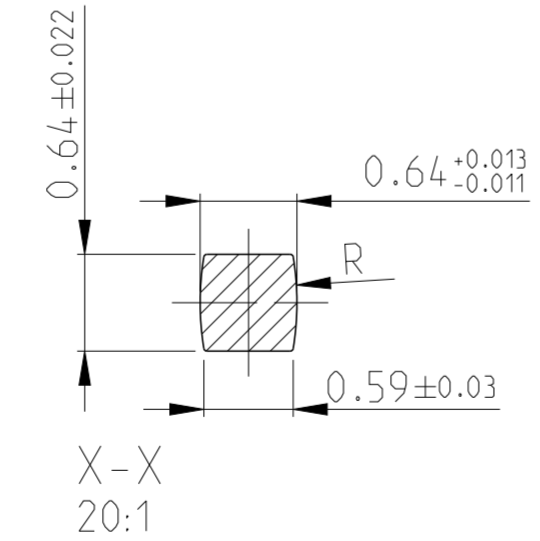

ROTATION PERMITTED
VERDREHUNG ERLAUBT

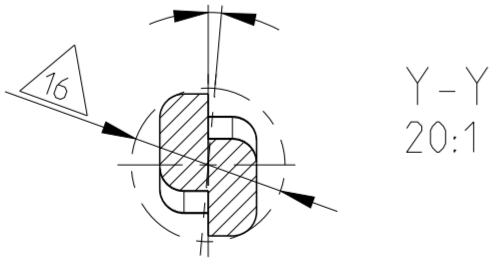

REFER SHEET 2 FOR NOTES

THIS DRAWING IS A CONTROLLED DOCUMENT.

DWN: A. HOFFMANN 15 JUN 1986
CHK: M. SCHAARSCHEIDT 15 JUN 1986
APVD: G. FELDMER 15 JUN 1986

STE TE Connectivity

NAME: AMPMODU II ACTION PIN FOR HOLE DIAMETER 0.9mm

PRODUCT SPEC: 108-18012
APPLICATION SPEC: -

MATERIAL: CuSn
FINISH: SEE NOTES

WEIGHT: -

CUSTOMER DRAWING

SCALE: 10:1 SHEET: 1 OF 2 REV: Z

REVISIONS

P	LTR	DESCRIPTION	DATE	DWN	APVD
-		SEE SHEET 1	-	-	-

NOTES:

1 AT AREA F MIN 0.8 µm GOLD OVER MIN 1.2 µm NICKEL AT AREA N;
AT AREA C 3.0 -6.0 µm TIN OVER MIN 1.2 µm NICKEL

2 PRESS-IN AREA FOR 1.6mm PCB
REQUIREMENTS FOR PCB HOLE

PLATED HOLE:
DRILL-Ø: 1.0 ±0.025
Cu-THICKN.: 25 - 50 µm
Sn-THICKN.: 4 - 10 µm
FINISHED HOLE-Ø: 0.9 ±0.07

UNPLATED HOLE:
DRILL-Ø: 1.0 ±0.025
FOR SOLDER APPLICATION

ALTERNATIVE-PLATING:
Cu-THICKN.: 25 - 50 µm
Ni-THICKN.: 1.3 - 5 µm
Au-THICKN.: 0.05 - 0.2 µm

9 3 REEL UNIT 50.000 PIECES. REEL-Ø 600mm / Ø588mm
REEL THICKNESS SEE TABLE

4 SOLDERABILITY ACC. TO IEC 60068 - 2 - 20; TEST Ta

5 AT AREA N 3.0-6.0 µm TIN OVER MIN 1.2 µm NICKEL

6 AT AREA F 1-2 µm TIN; AT AREA C 3.0-6.0 µm TIN
OVER MIN 1.2 µm NICKEL

15 7 CUT AREA FOR LOOSE PIECE PARTS DURING THE STITCHING INTO PCB
DIMENSION IS DETERMINED BY THE TOOL OF THE STITCHING MACHINE

8 1000 PIECES ARE PACKED INTO SHOCK-PROOF BOX
AND CLOSED WITH COVER

10 AT AREA N MIN. 2.5 µm TIN OVER MIN 1.2 µm NICKEL

12 AT AREA N 1-2 µm TIN OVER MIN 1.2 µm NICKEL

13 AT AREA F 2-4 µm TIN OVER MIN 1.2 µm NICKEL AT AREA N;
AT AREA C MIN. 1.2 µm TIN OVER MIN 1.2 µm NICKEL

14 AT AREA F MIN 0.8 µm GOLD OVER MIN 1.2 µm NICKEL AT AREA N;
AT AREA C 1.3-2.5 µm TIN OVER MIN 1.2 µm NICKEL

17 OBSOLETE PARTS: OBSOLETE CIS STREAMLINING PER D.RENAUD/D.SINISI

18 OBSOLETE

19 AT AREA F MIN. 1.2 µm GOLD OVER MIN 1.2 µm NICKEL AT AREA N;
AT AREA C 1.3-2.5 µm TIN OVER MIN 1.2 µm NICKEL

20 AT AREA F 1.5-5.0 µm SILVER (WEIGHT% ≥98.0) OVER MIN 1.2 µm NICKEL AT AREA N
AT AREA C 3.0-6.0 µm TIN OVER MIN 1.2 µm NICKEL

21 PACKED ON PLASTIC REEL

22 PACKED ON CARDBOARD REEL

1 IM BEREICH F MIN. 0.8 µm GOLD ÜBER MIN. 1.2 µm NICKEL IM BEREICH N;
IM BEREICH C 3.0-6.0 µm ZINN ÜBER MIN. 1.2 µm NICKEL

2 EINPRESSZONE FÜR 1.6mm LEITERPLATTE
ANFORDERUNG AN DIE LEITERPLATTENBOHRUNG

PLATTIERTES LOCH:
BOHR-Ø: 1.0 ±0.025
Cu-DICKE: 25 - 50 µm
Sn-DICKE: 4 - 10 µm
FERTIGLOCH-Ø: 0.9 ±0.07

NICHT PLATTIERTES LOCH:
BOHR-Ø: 1.0 ±0.025
ZUM LÖTEN

ALTERNATIV-PLATING:
Cu-DICKE: 25 - 50 µm
Ni-DICKE: 1.3 - 5 µm
Au-DICKE: 0.05 - 0.2 µm

9 3 ROLLENEINHEIT 50.000 STIFTE. ROLLEN-Ø 600mm / Ø588mm
ROLLENDICKE SIEHE TABELLE

4 LÖTBARKEIT NACH IEC 60068 - 2 - 20; PRÜFUNG Ta

5 IM BEREICH N 3.0-6.0 µm ZINN ÜBER MIN. 1.2 µm NICKEL

6 IM BEREICH F 1-2 µm ZINN; IM BEREICH C 3.0-6.0 µm ZINN
ÜBER JE MIN. 1.2 µm NICKEL

15 7 SCHNITTSTELLE FÜR EINZELSTIFT BEIM EINSETZEN IN PCB
MAß IST DURCH WERKZEUG AN DER JEWEILIGEN
EINSETZMASCHINE VORGEZEIGT

8 1000 STIFTE IN STOBSICHERE SCHACHTEL VERPACKT
UND MIT DECKEL VERSCHLOSSEN

10 IM BEREICH N MIN. 2.5 µm ZINN ÜBER MIN. 1.2 µm NICKEL

12 IM BEREICH N 1-2 µm ZINN ÜBER MIN. 1.2 µm NICKEL

13 IM BEREICH F 2-4 µm ZINN ÜBER 1.2 µm NICKEL IM BEREICH N;
IM BEREICH C MIN. 1.2 µm ZINN ÜBER MIN. 1.2 µm NICKEL

14 IM BEREICH F MIN. 0.8 µm GOLD ÜBER MIN. 1.2 µm NICKEL IM BEREICH N;
IM BEREICH C 1.3-2.5 µm ZINN ÜBER MIN. 1.2 µm NICKEL

17 OBSOLETE PARTS: OBSOLETE CIS STREAMLINING PER D.RENAUD/D.SINISI

18 OBSOLETE

19 IM BEREICH F MIN. 1.2 µm GOLD ÜBER MIN. 1.2 µm NICKEL IM BEREICH N;
IM BEREICH C 1.3-2.5 µm ZINN ÜBER MIN. 1.2 µm NICKEL

20 IM BEREICH F 1.5-5.0 µm SILBER (GEWICHT% ≥98.0) ÜBER MIN 1.2 µm NICKEL IM BEREICH N;
IM BEREICH C 3.0-6.0 µm ZINN ÜBER MIN. 1.2 µm NICKEL

21 VERPACKT AUF PLASTIKHASPEL

22 AUF KARTONROLLE VERPACKT

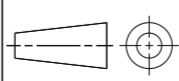
THIS DRAWING IS A CONTROLLED DOCUMENT.		DWN A.HOFFMANN 15 JUN 1986	 TE Connectivity		
DIMENSIONS: mm		CHK M.SCHAARSCHEIDT 15 JUN 1986			
TOLERANCES UNLESS OTHERWISE SPECIFIED:		APVD G.FELDMEIER 15 JUN 1986	NAME AMPMODU II ACTION PIN FOR HOLE DIAMETER 0.9mm		
		PRODUCT SPEC 108-18012	RESTRICTED TO		
MATERIAL CuSn		APPLICATION SPEC -	SIZE A2	CAGE CODE 100779	DRAWING NO G-928776
FINISH SEE NOTES		WEIGHT -	SCALE 10:1	SHEET 2 OF 2	REV Z
		CUSTOMER DRAWING			