

100 Watts ALH25-Dual

Total Power: 100 Watts
Input Voltages: 48V
No. of Outputs: Dual



Special Features

- 100W Output loadsharing
- 48VDC Input
- Open Frame 2.3" x 2.4" x 0.50" pkg.
- -40 to 120°C board temperature
- Trim feature, both rails
- Industry standard pin-out
- Enable (on/off) (pos or neg logic)
- OC, OV, OT protection
- 5.0V/3.3V dual outputs

Environmental

Operating PCB temperature range:

-40°C to +120°C

Storage temperature: -55°C to +125°C

Weight 80 grams

Safety

UL UL 1950 Pending
CAN22.2-950 Pending

TUV EN60950 Pending

Electrical Specs

Input

Input range	36 to 75 VDC (48Vdc Nom.)
Efficiency	88% typical
Input reverse	
Voltage protection	Fuse recommended 3A.MB
Input surge voltage	100V for 100mS

Output

Voltage tolerance	± 1%
Line regulation	±0.2%
Load regulation	±0.5%
Ripple/noise	200mV P-P
Temperature coefficient	+0.02%/°C (max)
Transient response	3% Vo max recovery <500msec (50% to 75% step load change)
Switching frequency	250 kHz typical

Control

Enable	on = 1.2Vdc Max (Neg Enable) off = 3Vdc Min (Neg Enable) Ref. to -Vin. TTL compatible
Input current (enable off)	<2ma.
Output trim	Both outputs ±10% minimum

Isolation

I/O isolation	1500 VDC
---------------	----------

AMERICAS

5810 Van Allen Way
 Carlsbad, CA 92008
 Telephone: 760-930-4600
 Facsimile: 760-930-0698

EUROPE

Astec House, Waterfront Business Park
 Merry Hill, Dudley
 West Midlands, DY5 1LX, UK
 Telephone: 44 (1384) 842-211
 Facsimile: 44 (1384) 843-355

ASIA

Units 2111-2116, Level 21
 Tower1, Metroplaza
 223, Hing Fong Road
 Fwai Fong, New Territories
 Hong Kong
 Telephone: 852-2437-9662
 Facsimile: 852-2402-4426



Ordering Information

Input Voltage	Output 1 Voltage	Output 2 Voltage	Model Number
36 - 75VDC	5.0V @ 20A	3.3V @ 25A	ALH25AF48

Note:

Enable Function

"N" = negative logic enable (without "N" = positive enable)

1. Maximum output power not to exceed 100W total for 5/3.3V version 20/25A).
2. Any output loading ratio within the maximum specified limits is possible.

Pin Assignments

Dual Output

1. -Vin
2. Case
3. Control (on/off)
4. Vin+
5. V2
6. Rtn (V2)
7. Trim (V2)
8. V1
9. Rtn (V1)
10. Trim (V1)

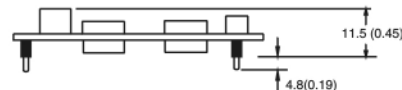
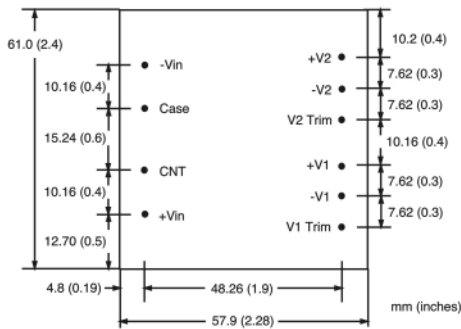

Notes:

1. 20MHz bandwidth. An external 2.2mf ceramic capacitor is recommended to be placed from +V out to -V out.
2. Recommended External components below:
 C1 = 100uF/100V, C2=C4= metallic film .47uF/50V
 C3= C5 = Electrolytic 1000uF/10V, C6 = .01uF/1500V
3. All specifications are typical at nominal line, full load, and 25°C unless otherwise noted.
4. All specifications subject to change without notice. Mechanical drawings are for reference only.
5. Please refer to the Technical Reference Notes for more information.
6. Warranty: 1 yr

