

Silicon Super Fast Recovery Diode

$V_{RRM} = 400\text{ V} - 600\text{ V}$

$I_F = 25\text{ A}$

Features

- High Surge Capability
- Types from 400 V to 600 V V_{RRM}
- Not ESD Sensitive

Note:

1. Standard polarity: Stud is cathode.
2. Reverse polarity (R): Stud is anode.
3. Stud is base.

DO-4 Package

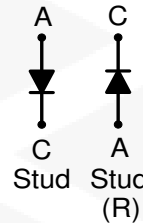

Maximum ratings, at $T_j = 25\text{ }^\circ\text{C}$, unless otherwise specified ("R" devices have leads reversed)

Parameter	Symbol	Conditions	MUR2540 (R)	MUR2560 (R)	Unit
Repetitive peak reverse voltage	V_{RRM}		400	600	V
RMS reverse voltage	V_{RMS}		280	420	V
DC blocking voltage	V_{DC}		400	600	V
Continuous forward current	I_F	$T_C \leq 145\text{ }^\circ\text{C}$	25	25	A
Surge non-repetitive forward current, Half Sine Wave	$I_{F,SM}$	$T_C = 25\text{ }^\circ\text{C}$, $t_p = 8.3\text{ ms}$	500	500	A
Operating temperature	T_j		-55 to 150	-55 to 150	$^\circ\text{C}$
Storage temperature	T_{stg}		-55 to 150	-55 to 150	$^\circ\text{C}$

Electrical characteristics, at $T_j = 25\text{ }^\circ\text{C}$, unless otherwise specified

Parameter	Symbol	Conditions	MUR2540 (R)	MUR2560 (R)	Unit
Diode forward voltage	V_F	$I_F = 25\text{ A}$, $T_j = 25\text{ }^\circ\text{C}$	1.3	1.7	V
Reverse current	I_R	$V_R = 50\text{ V}$, $T_j = 25\text{ }^\circ\text{C}$	10	10	μA
		$V_R = 50\text{ V}$, $T_j = 125\text{ }^\circ\text{C}$	3	3	mA

Recovery Time

Maximum reverse recovery time	T_{RR}	$I_F = 0.5\text{ A}$, $I_R = 1.0\text{ A}$, $I_{RR} = 0.25\text{ A}$	75	90	ns
-------------------------------	----------	---	----	----	----

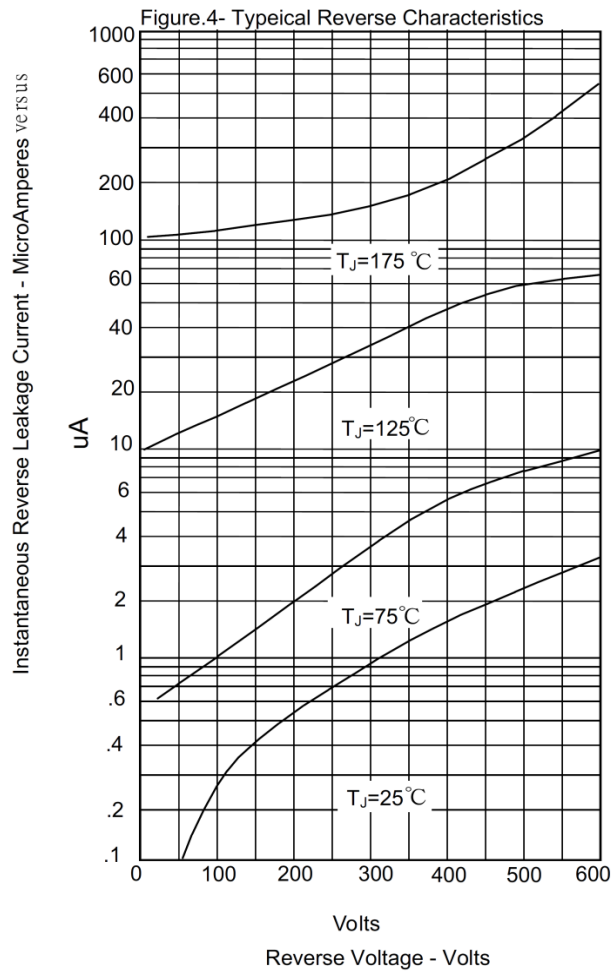
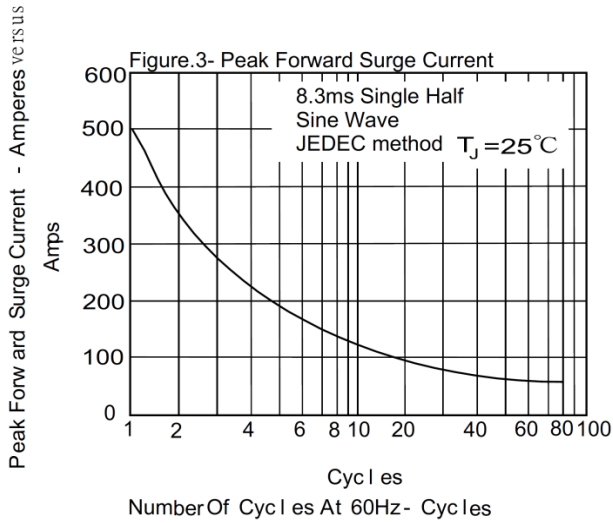
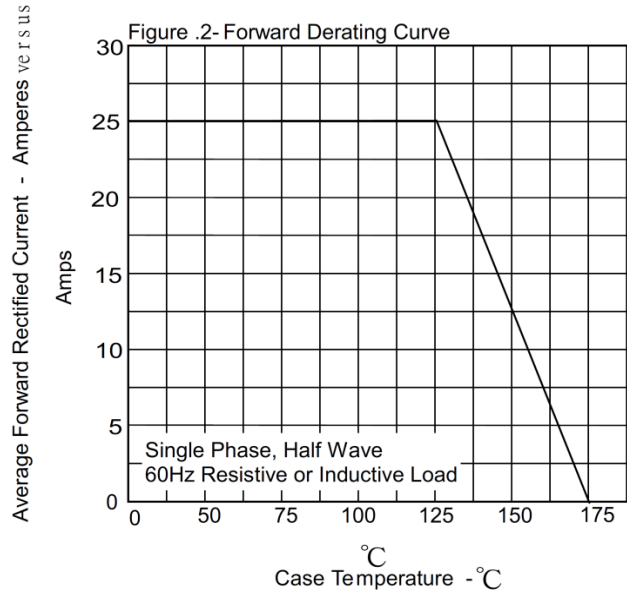
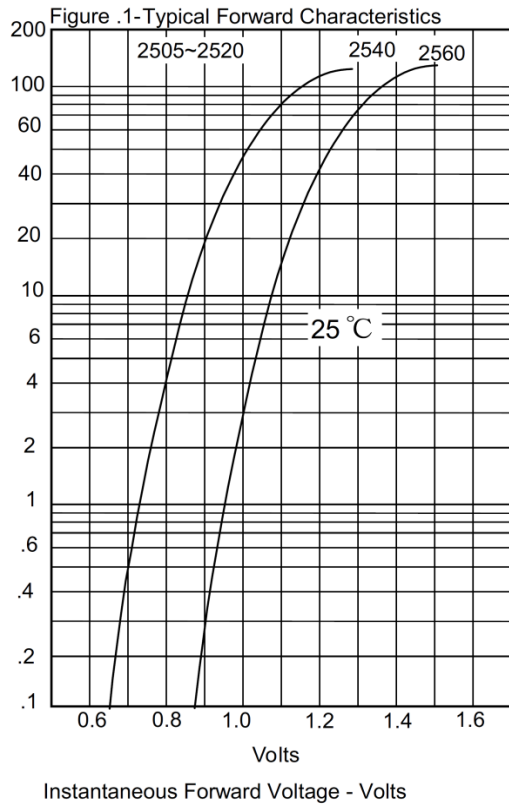

Package dimensions and terminal configuration

Product is marked with part number and terminal configuration.

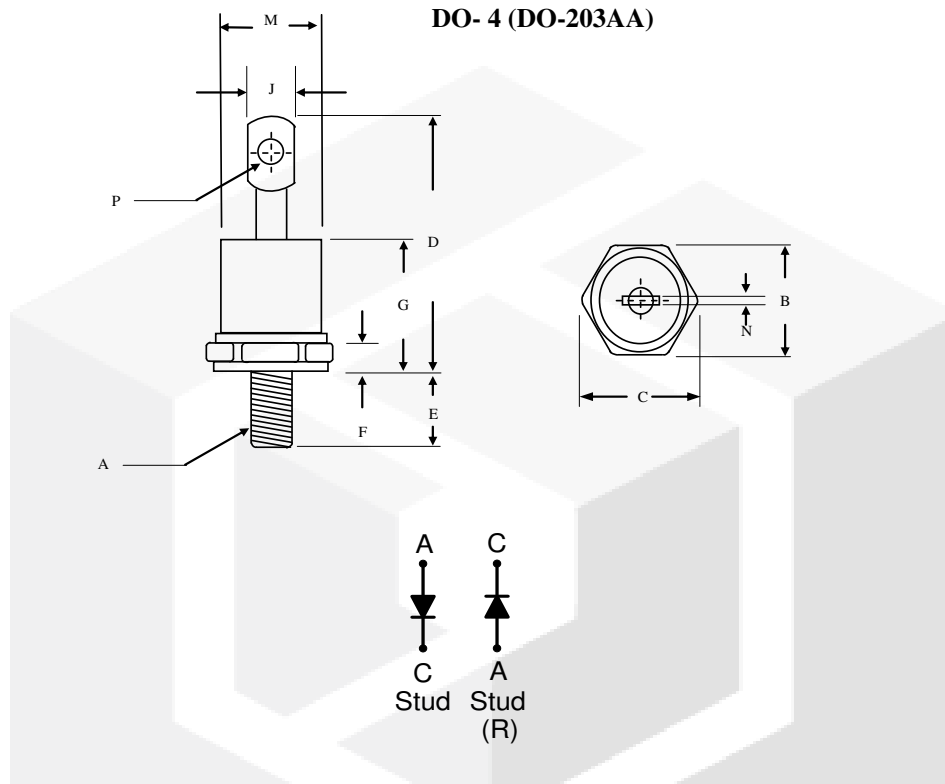

	Inches		Millimeters	
	Min	Max	Min	Max
A	10-32 UNF			
B	0.424	0.437	10.77	11.10
C	-----	0.505	-----	12.82
D	-----	0.800	-----	20.30
E	0.453	0.492	11.50	12.50
F	0.114	0.140	2.90	3.50
G	-----	0.405	-----	10.29
J	-----	0.216	-----	5.50
M	-----	φ0.302	-----	φ7.68
N	0.031	0.045	0.80	1.15
P	0.070	0.79	1.80	2.00