

PRODUCT NUMBER	QUANTITY PER REEL	PACKAGING
76785-Y01LF	15000	CARDBOARD REEL
76785-Y11LF	3000	CARDBOARD REEL

RoHS COMPATIBLE, SEE NOTE 3

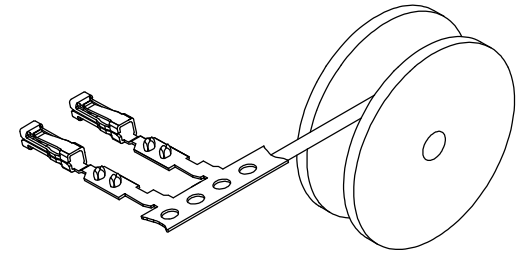

REELING AFTER STAMPING

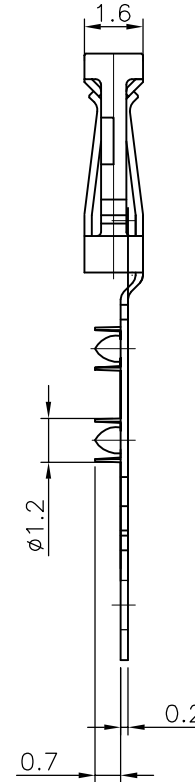
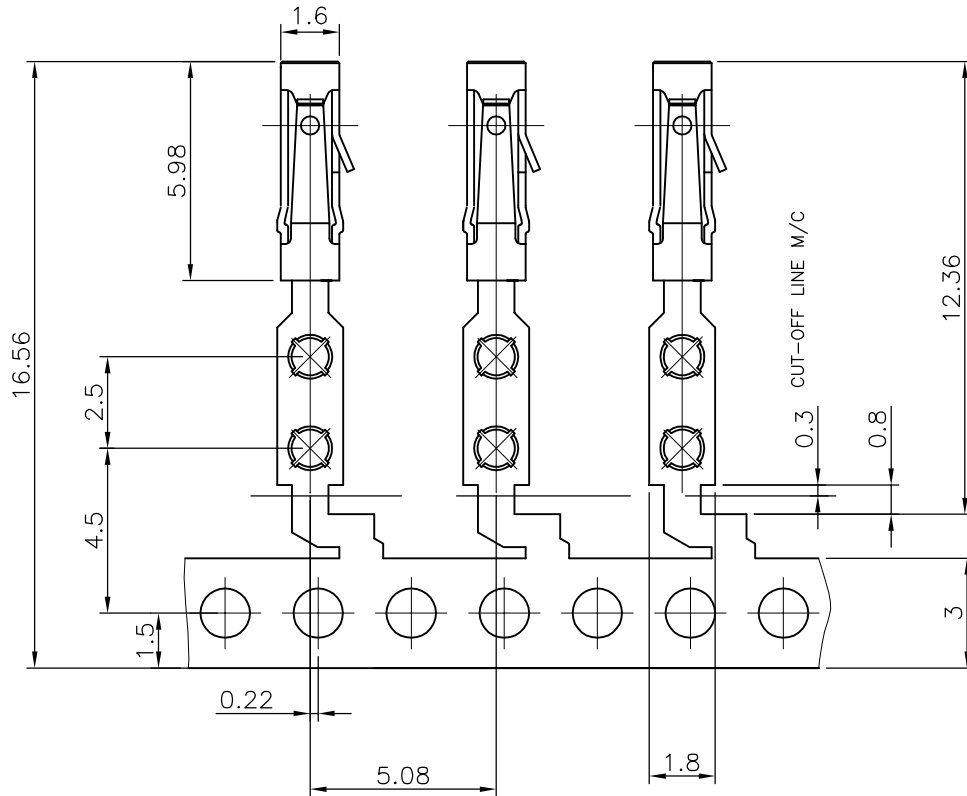

NOTES:

- 1 - MATERIAL: PHOSPHOR BRONZE, EXTRA HARD
- 2 - FOR APPLICATION DATA, SEE TA 338
- 3 - RoHS COMPATIBLE PRODUCT SPECIFICATIONS
 - a - PLATING:
 - "LF" MEANS THE PRODUCT IS LEAD-FREE, 2µm MINIMUM MATTE TIN OVER 1.27µm MINIMUM NICKEL UNDERPLATE.
 - b - LABELING:
 - MEETS PACKAGING SPECS AS PER GS-14-920
 - c - LEGAL STATEMENT: SEE GS-47-0004

THE PRODUCT IS NOT INTENDED TO BE EXPOSED TO A MANUFACTURING SOLDER PROCESS.

76785-3XXLF	0.75µm Au MIN. OVER 1.3µm Ni MIN.	Sn OVER Ni	0.3 N MIN
			0.6 N MAX
76785-4XXLF	5µm Sn MIN. OVER 1.27µm Ni MIN.	Sn OVER Ni	0.3 N MIN
			0.6 N MAX
PLATING CODE	CONTACT AREA	SOLDER TAIL	WITHDRAWAL FORCE USING SQUARE PIN
PLATING EXPLANATION			0.61

mat'l. code		surface	tolerance	projection	product family	
SEE NOTE		ISO 1302	ISO 406 ISO 101		DUFLEX	
Ltr	ecm no	dr	date	tolerances unless otherwise specified	title	
M	F05-0286	DLE	05.11.07	.X±.3	DUFLEX	
N	F06-0196	DLE	06.06.13	linear .XX±.13	TERMINAL	
P	B-19779	BVE	14.12.18	.XXX±.08	scale 10:1	
		dr	D LEGRAND	06.06.12	FCI	
		engr	P NIZZI	06.06.12		
		chr	D LE	06.06.12		
		appd	P NZ	06.06.12		
sheet index	revision sheet				dwg no	sheet 1 of 1 size
					76785	A2
					type	Product Customer Drawing