

## Ceramic Singlelayer DC Disc Capacitors Class 2, 500 V<sub>DC</sub>, 1 kV<sub>DC</sub>, General Purpose



QUICK REFERENCE DATA	
DESCRIPTION	VALUE
Ceramic Class	2
Ceramic Dielectric	X7R
Voltage (V <sub>DC</sub> )	500, 1000
Min. Capacitance (pF)	1000
Max. Capacitance (pF)	4700
Mounting	Radial

### MARKING

Marking indicates capacitance value and tolerance in accordance with "EIA 198".

The capacitors meet the essential requirements of "EIA 198". Unless stated otherwise all electrical values apply at an ambient temperature of 25 °C ± 3 °C, at normal atmospheric conditions.

### OPERATING TEMPERATURE RANGE

Class 2, - 55 °C to +125 °C

### TEMPERATURE COEFFICIENTS

Class 2, X7R

### SECTIONAL SPECIFICATIONS

Class 2, IEC 60 384-9,  
EIA 198

### CLIMATIC CATEGORY

Class 2, 55/125/21

### FEATURES

- High capacitance in small size
- Kinked (preferred) or straight leads
- Material categorization:  
for definitions of compliance please see  
[www.vishay.com/doc?99912](http://www.vishay.com/doc?99912)



**RoHS**  
COMPLIANT

### APPLICATIONS

- Bypassing
- Coupling
- Resonant circuit

### DESIGN

The capacitors consist of a ceramic disc both sides of which are silver-plated. Connection leads are made of tinned copper having a diameter of 0.6 mm.

The capacitors have inward kinked leads with a spacing of 5 mm (0.200") or 7.5 mm (0.300") and a lead length from 4 mm to 30 mm. Encapsulation is made of phenolic resin for 500 V<sub>DC</sub> and epoxy resin for 1 kV<sub>DC</sub>.

### CAPACITANCE RANGE

Class 2, at 1 kHz, 1 V<sub>RMS</sub> ± 0.2 V<sub>RMS</sub>; 1000 pF to 4700 pF

### RATED DC VOLTAGE

500 V and 1 kV

### DIELECTRIC STRENGTH

250 % of rated voltage for 500 V<sub>DC</sub>  
200 % of rated voltage for 1 kV<sub>DC</sub>

### INSULATION RESISTANCE AT 500 V<sub>DC</sub>

≥ 10 000 MΩ

### TOLERANCE ON CAPACITANCE

± 10 %; ± 20 %

### DISSIPATION FACTOR

Class 2, ≤ 2.5 %

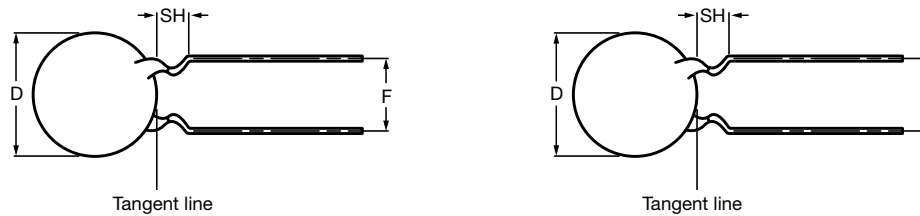
**DIMENSIONS**

Capacitors with 5 mm (0.20") and 7.5 mm (0.30") lead spacing

**ORDERING INFORMATION (PREFERRED TYPES), CLASS 2, 500 V<sub>DC</sub>, KINKED**

C (pF)	TOL. (%)	D <sub>MAX.</sub> (mm)	LEAD SPACING (mm)	SH <sup>(1)</sup> (mm)	CLEAR TEXT CODE
					13 <sup>TH</sup> DIGIT: T = REEL; U = AMMO; 3 = BULK
<b>CLASS 2 X7R</b>					
1000	± 10	6.5	5.0	4.0	H102K25X7RL6.J5R
1500		7.5			H152K29X7RL6.J5R
2200		8.5			H222K33X7RL6.J5R
3300		10	H332K39X7RL6.J5R		
4700		12	7.5		H472K47X7RL6.J7R

**Notes**

- <sup>(1)</sup> SH = Seated height
- Maximum thickness 4.0 mm
  - Lead style codes refer to inward kinked leads. Other styles available on request

**ORDERING INFORMATION (PREFERRED TYPES), CLASS 2, 1 kV<sub>DC</sub>, KINKED**

C (pF)	TOL. (%)	D <sub>MAX.</sub> (mm)	LEAD SPACING (mm)	SH <sup>(1)</sup> (mm)	CLEAR TEXT CODE
					13 <sup>TH</sup> DIGIT: T = REEL; U = AMMO; 3 = BULK
<b>CLASS 2 X7R</b>					
1000	± 10	6.5	5.0	4.0	H102K25X7RN6.J5R
1500		8			H152K31X7RN6.J5R
2200		9			H222K35X7RN6.J5R
3300		10.5	H332K41X7RN6.J5R		
4700		12	7.5		H472K47X7RN6.J7R

**Notes**

- <sup>(1)</sup> SH = Seated height
- Maximum thickness 4.0 mm
  - Lead style codes refer to inward kinked leads. Other styles available on request

**PACKAGING**

D <sub>MAX.</sub> (mm)	SIZE CODE	PACKAGING QUANTITIES		
		BULK	REEL	AMMO
5.0 (0.20")	20	1000	2000	2000
6.5 (0.25")	25			
7.5 (0.29")	29			
8.5 (0.33")	33			
10.0 (0.39")	39			
11.0 (0.43")	43			
12.0 (0.47")	47	500	-	-
13.5 (0.53")	53			
15.0 (0.59")	59			
17.5 (0.69")	69			

**Note**

- The capacitors are supplied in bulk packaging (cardboard boxes), in tape on reel or in ammpack.

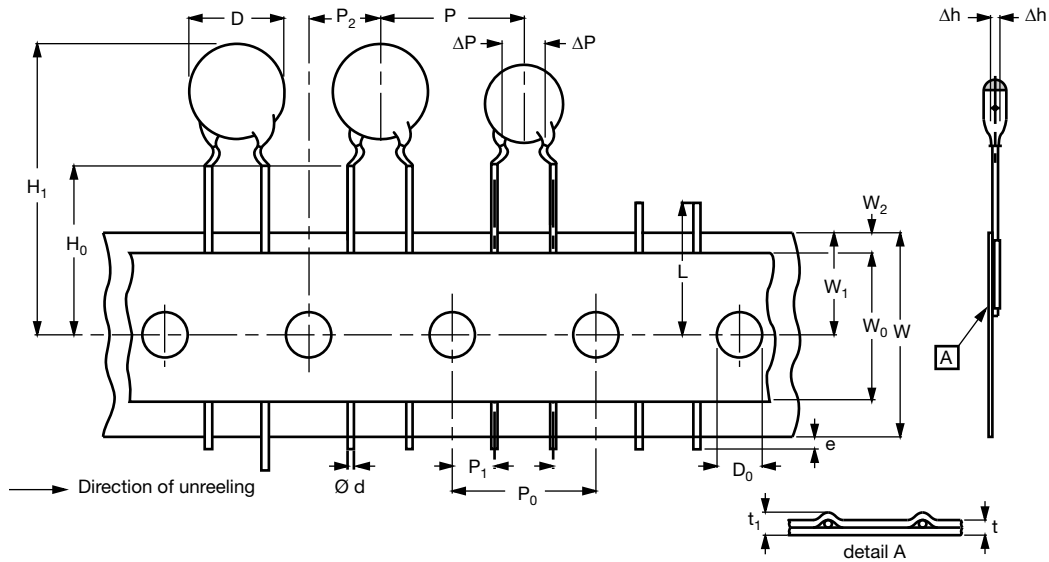

Kinked capacitors on tape, lead spacing 5.0 mm (0.2")

DIMENSIONS OF TAPE			
SYMBOL	PARAMETER	DIMENSIONS (mm)	
		NOMINAL	TOLERANCE
D	Body diameter	11.0 maximum	-
d	Lead diameter	0.6	± 0.05
P	Pitch between capacitors	12.7	± 1.0
P <sub>0</sub> <sup>(1)</sup>	Feed-hole pitch	12.7	± 0.3
ΔP	Plane deviation	1.0 maximum	-
P <sub>1</sub> <sup>(2)</sup>	Feed-hole center to lead center	3.85	± 0.7
P <sub>2</sub> <sup>(2)</sup>	Feed-hole center to component center	6.35	± 1.3
F	Lead spacing	5.0	0.6 - 0.4
Δh	Component alignment	0	± 1.0
W	Tape width	18.0	1.0 - 0.5
W <sub>0</sub>	Hold-down tape width	5.0 minimum	-
W <sub>1</sub>	Hole position	9.0	0.75 - 0.5
W <sub>2</sub>	Hold-down tape margin	3.0 maximum	-
H <sub>0</sub>	Height to seating plane	16.0	± 0.5
H <sub>1</sub>	Maximum component height	32.0	-
e	Lead end protrusion	1.0 maximum	-
L	Maximum length of snapped lead	11.0	-
D <sub>0</sub>	Feed-hole diameter	4.0	± 0.2
t	Total tape thickness	0.9 maximum	-
t <sub>1</sub>	Maximum thickness of tape and wires	1.5 maximum	-

**Notes**

- (1) Cumulative pitch error: ± ≤ 1 mm/20 pitches  
 (2) Obliquity maximum 3°



### REEL AND TAPE DATA in millimeters

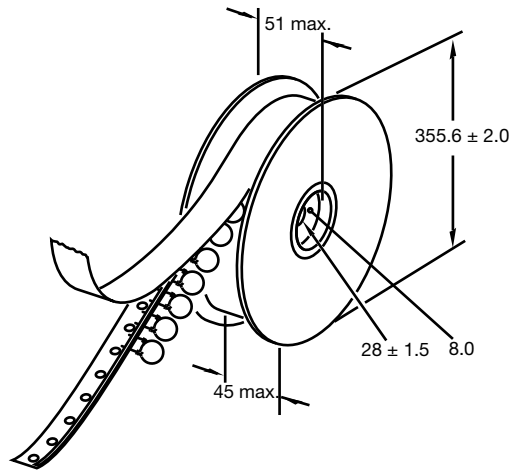

Reel with capacitors on tape

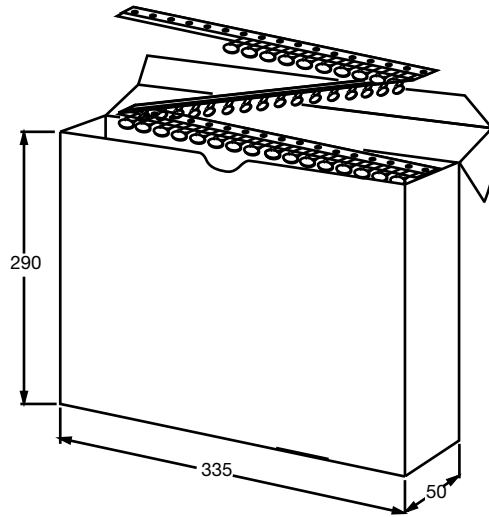

Ammopack with capacitors on tape



## **Disclaimer**

ALL PRODUCT, PRODUCT SPECIFICATIONS AND DATA ARE SUBJECT TO CHANGE WITHOUT NOTICE TO IMPROVE RELIABILITY, FUNCTION OR DESIGN OR OTHERWISE.

Vishay Intertechnology, Inc., its affiliates, agents, and employees, and all persons acting on its or their behalf (collectively, "Vishay"), disclaim any and all liability for any errors, inaccuracies or incompleteness contained in any datasheet or in any other disclosure relating to any product.

Vishay makes no warranty, representation or guarantee regarding the suitability of the products for any particular purpose or the continuing production of any product. To the maximum extent permitted by applicable law, Vishay disclaims (i) any and all liability arising out of the application or use of any product, (ii) any and all liability, including without limitation special, consequential or incidental damages, and (iii) any and all implied warranties, including warranties of fitness for particular purpose, non-infringement and merchantability.

Statements regarding the suitability of products for certain types of applications are based on Vishay's knowledge of typical requirements that are often placed on Vishay products in generic applications. Such statements are not binding statements about the suitability of products for a particular application. It is the customer's responsibility to validate that a particular product with the properties described in the product specification is suitable for use in a particular application. Parameters provided in datasheets and / or specifications may vary in different applications and performance may vary over time. All operating parameters, including typical parameters, must be validated for each customer application by the customer's technical experts. Product specifications do not expand or otherwise modify Vishay's terms and conditions of purchase, including but not limited to the warranty expressed therein.

Hyperlinks included in this datasheet may direct users to third-party websites. These links are provided as a convenience and for informational purposes only. Inclusion of these hyperlinks does not constitute an endorsement or an approval by Vishay of any of the products, services or opinions of the corporation, organization or individual associated with the third-party website. Vishay disclaims any and all liability and bears no responsibility for the accuracy, legality or content of the third-party website or for that of subsequent links.

Except as expressly indicated in writing, Vishay products are not designed for use in medical, life-saving, or life-sustaining applications or for any other application in which the failure of the Vishay product could result in personal injury or death. Customers using or selling Vishay products not expressly indicated for use in such applications do so at their own risk. Please contact authorized Vishay personnel to obtain written terms and conditions regarding products designed for such applications.

No license, express or implied, by estoppel or otherwise, to any intellectual property rights is granted by this document or by any conduct of Vishay. Product names and markings noted herein may be trademarks of their respective owners.