

BIDIRECTIONAL THYRISTOR OVERVOLTAGE PROTECTORS



9ELx Primary Protector Series

- Ion-Implanted Breakdown Region**
 - Precise and Stable Voltage
 - Low Voltage Overshoot under Surge

Device	V _(BR) Minimum V	V _(BO) Minimum V	V _(BO) Maximum V
9EL2	±245	±265	±400
9EL3		±200	±265

Cell Package (Side View)

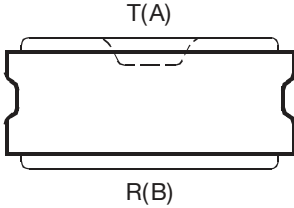

MD4XACAa

Rated for International Surge Wave Shapes

Device	ITU-T K28 (10/700) I _{TSP} A	GR-974-CORE (10/1000) I _{TSP} A
9EL2	±200	±150
9EL3	±125	±100

Device Symbol



SD4XAA

Terminals T and R correspond to the alternative line designators of A and B

Gas Discharge Tube (GDT) Replacement

- Planar Passivated Junctions in a Protected Cell Construction**
 - Low Off-State Current
 - Extended Service Life

- Soldered Copper Electrodes**
 - High Current Capability
 - Cell Construction Short Circuits Under Excessive Current Conditions

 UL Recognized Components

Description

These devices are primary protector components for semiconductor arrester assemblies intended to meet the generic requirements of Telcordia GR-974-CORE or ITU-T Recommendation K28 (03/93). To conform to the specified environmental requirements, the 9ELx must be installed in a housing which maintains a stable microclimate during these tests (e.g. FIGURE I.1/K28).

The protector consists of a symmetrical voltage-triggered bidirectional thyristor. Overvoltages are initially clipped by breakdown clamping until the voltage rises to the breakover level, which causes the device to crowbar into a low-voltage on state. This low-voltage on state causes the current resulting from the overvoltage to be safely diverted through the device. In usual applications, the high crowbar holding current prevents d.c. latchup as the diverted current subsides. This 9ELx range consists of two voltage variants to meet various maximum system voltage levels. They are designed to voltage limit and withstand the listed international lightning surges in both polarities.

These monolithic protection devices are constructed using two nickel plated copper electrodes soldered to each side of the silicon chip. This packaging approach allows heat to be removed from both sides of the silicon, resulting in the doubling of the devices thermal capacity, enabling a power line cross current capability of 10 A rms for 1 second. One of the 9ELx's copper electrodes is specially shaped to promote a progressive shorting action (at 50/60 Hz currents greater than 60 A). The assembly must hold the 9ELx in compression, so that the cell electrodes can be forced together during overstress testing. Under excessive power line cross conditions the 9ELx will fail short circuit, providing maximum protection to the equipment.

JANUARY 1994 - REVISED OCTOBER 2003
 Specifications are subject to change without notice.
 Customers should verify actual device performance in their specific applications.

9ELx Primary Protector Series

BOURNS®

Absolute Maximum Ratings, $T_A = 25\text{ }^\circ\text{C}$ (Unless Otherwise Noted)

Rating	Symbol	Value	Unit
Non-repetitive peak on-state pulse current (see Notes 1 and 2) 5/310 μs (ITU-T K28, 10/700 μs voltage wave shape)	I_{TSP}	9EL2 -20 $^\circ\text{C}$ to 65 $^\circ\text{C}$	200
9EL3 0 $^\circ\text{C}$ to 65 $^\circ\text{C}$		125	
10/1000 μs (GR-974-CORE, 10/1000 μs voltage wave shape)		9EL2 -20 $^\circ\text{C}$ to 65 $^\circ\text{C}$	150
9EL3 0 $^\circ\text{C}$ to 65 $^\circ\text{C}$		100	
Non-repetitive peak on-state current (see Note 1) full sine wave, 50/60 Hz, 1 s	I_{TSM}	9EL2 -40 $^\circ\text{C}$ to 65 $^\circ\text{C}$	10
9EL3 0 $^\circ\text{C}$ to 65 $^\circ\text{C}$		10	
Junction temperature	T_J	-40 to +150	$^\circ\text{C}$
Storage temperature range	T_{stg}	-40 to +150	$^\circ\text{C}$

- NOTES: 1. The surge may be repeated after the device has returned to thermal equilibrium.
2. Most PTTs quote an unloaded voltage waveform. In operation the 9ELx essentially shorts the generator output. The resulting loaded current waveform is specified.

Electrical Characteristics for the R and T Terminals, $T_A = 25\text{ }^\circ\text{C}$ (Unless Otherwise Noted)

Parameter	Test Conditions	Min	Typ	Max	Unit
$V_{(BR)}$ Breakdown Voltage	$I_{(BR)} = \pm 20\text{ mA}$, (see Note 3)	9EL2 -40 $^\circ\text{C}$ to 65 $^\circ\text{C}$	± 245		V
$V_{(BO)}$ Breakover voltage	$dv/dt = \pm 0.2\text{ V/s}$, $R_{SOURCE} > 200$	9EL2 +15 $^\circ\text{C}$ to 25 $^\circ\text{C}$	± 265	± 400	V
		9EL3 -40 $^\circ\text{C}$ to 65 $^\circ\text{C}$	± 200	± 265	
$V_{(BO)}$ Impulse breakover voltage	100 $\text{V}/\mu\text{s} \leq dv/dt \leq \pm 1000\text{ V}/\mu\text{s}$, $di/dt \leq 10\text{ A}/\mu\text{s}$	9EL2 -40 $^\circ\text{C}$ to 65 $^\circ\text{C}$		± 400	V
		9EL3 0 $^\circ\text{C}$ to 65 $^\circ\text{C}$		± 350	
Impulse reset	Sources are 52.5 V O.C., 260 mA S.C. and 135 V O.C., 200 mA S.C. on-state current 25 A, 10/1000 μs impulse	9EL2 -40 $^\circ\text{C}$ to 65 $^\circ\text{C}$		20	ms
		9EL3 0 $^\circ\text{C}$ to 65 $^\circ\text{C}$		20	
I_D Off-state current	$V_D = \pm 50\text{ V}$ (see Note 4) $V_D = \pm 200\text{ V}$	9EL2 -40 $^\circ\text{C}$ to 65 $^\circ\text{C}$		± 0.5	μA
		9EL3 0 $^\circ\text{C}$ to 65 $^\circ\text{C}$		± 0.5	
		9EL2 -40 $^\circ\text{C}$ to 65 $^\circ\text{C}$		± 10	
		9EL3 +15 $^\circ\text{C}$ to 25 $^\circ\text{C}$		± 1	
C_{off} Off-state capacitance	$f = 1\text{ MHz}$, $V_d = 1\text{ Vrms}$, $V_D = 0$,	9EL2 -40 $^\circ\text{C}$ to 65 $^\circ\text{C}$		150	pF
		9EL3 0 $^\circ\text{C}$ to 65 $^\circ\text{C}$		150	

- NOTES: 3. Meets Telcordia GR-974-CORE Issue 2, December 1999 - Rated Voltage Test (4.7).
4. This device is sensitive to light. Suggest that this parameter be measured in a dark environment.

Parameter Measurement Information

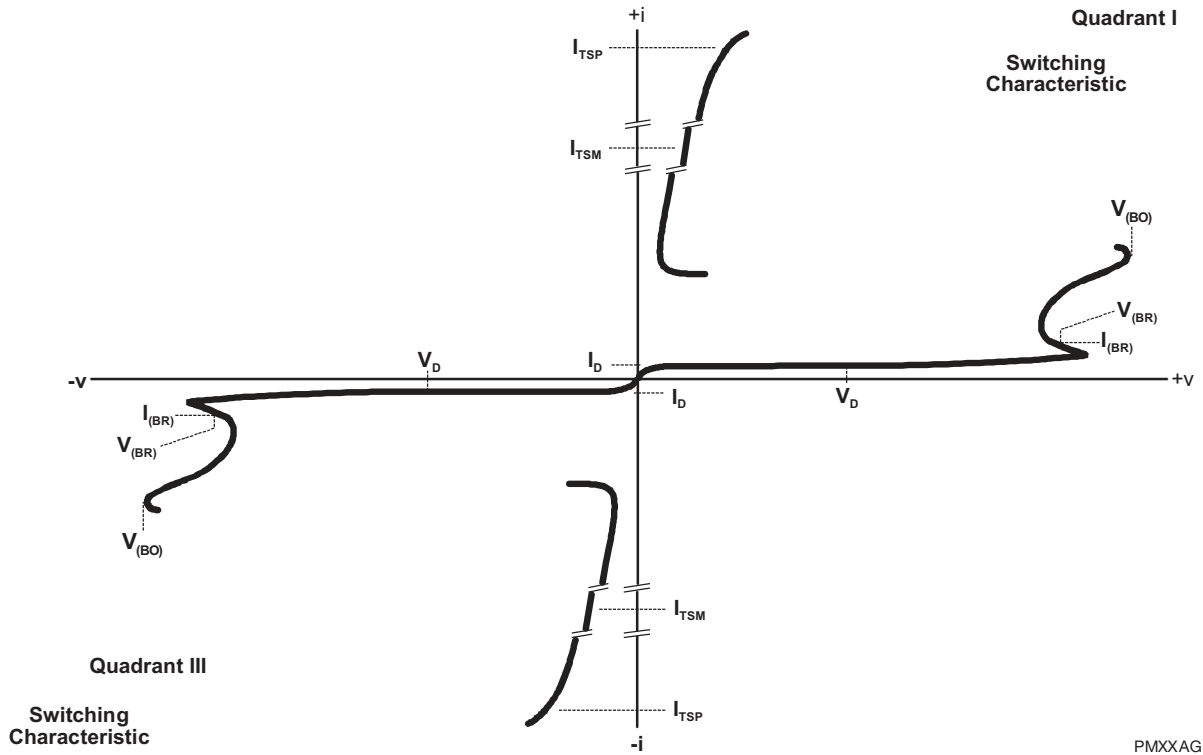

Figure 1. Voltage-Current Characteristic for the T and R Terminals
All Measurements are Referenced to the R Terminal

PMXXAG

9ELx Primary Protector Series

BOURNS®

Cell Package

BUTTON CELL 9ELx

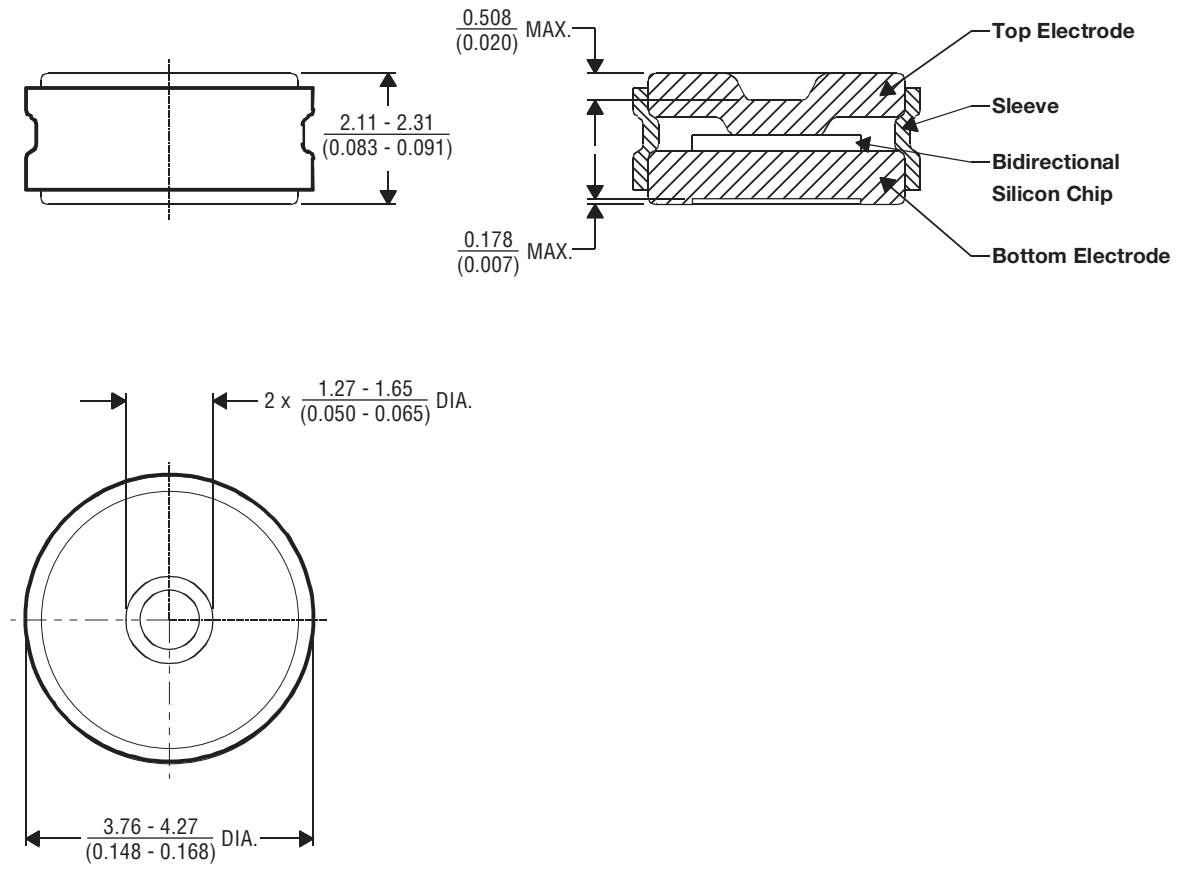

DIMENSIONS ARE : $\frac{\text{MILLIMETERS}}{\text{(INCHES)}}$

MDXXAVAA

Bourns Sales Offices

Region	Phone	Fax
The Americas:	+1-909-781-5500	+1-909-781-5700
	+1-951-781-5500	+1-951-781-5700 <i>(after 7/17/04)</i>
Europe:	+41(0)41-7685555	+41(0)41-7685510
Asia-Pacific:	+886-2-25624117	+886-2-25624116

Technical Assistance

Region	Phone	Fax
The Americas:	+1-909-781-5500	+1-909-781-5700
	+1-951-781-5500	+1-951-781-5700 <i>(after 7/17/04)</i>
Europe:	+41(0)41-7685555	+41(0)41-7685510
Asia-Pacific:	+886-2-25624117	+886-2-25624116

www.bourns.com

Bourns® products are available through an extensive network of manufacturer's representatives, agents and distributors. To obtain technical applications assistance, a quotation, or to place an order, contact a Bourns representative in your area.



Reliable Electronic Solutions

"Bourns" is a registered trademark of Bourns, Inc. in the U.S. and other countries.

COPYRIGHT© 2004, BOURNS, INC. LITHO IN U.S.A. e 03/04/TSP0340