

- NOTES:
- PART SHALL BE FREE OF BURRS AND SHARP EDGES
 - ASSURE ASSEMBLY CAPABILITY BY MATCHING WITH MATING PART
 - DIMENSIONS IN [] ARE IN MILLIMETERS

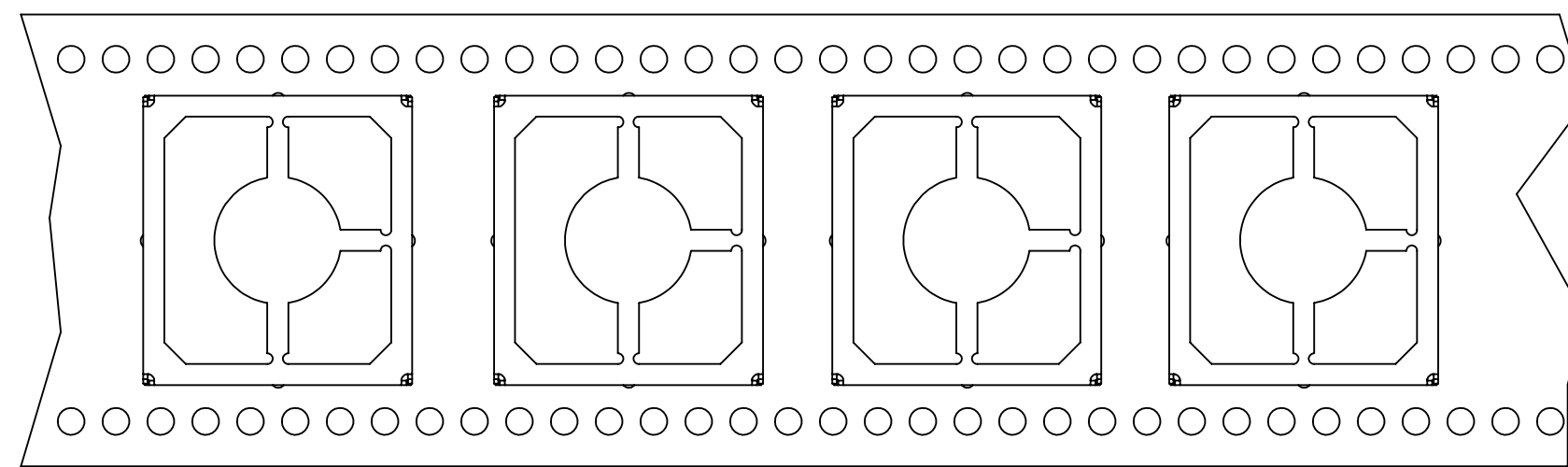
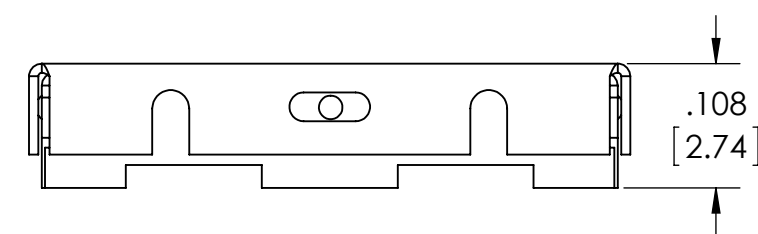
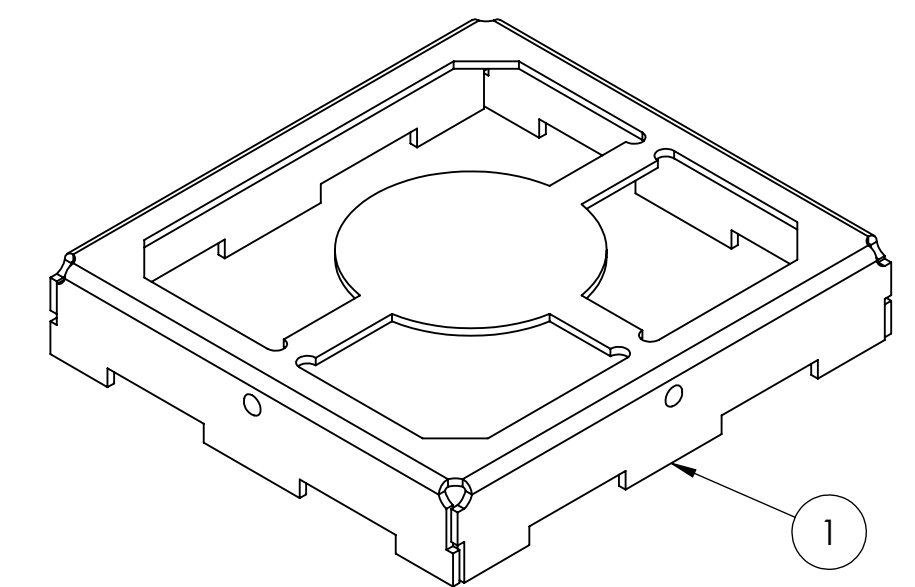
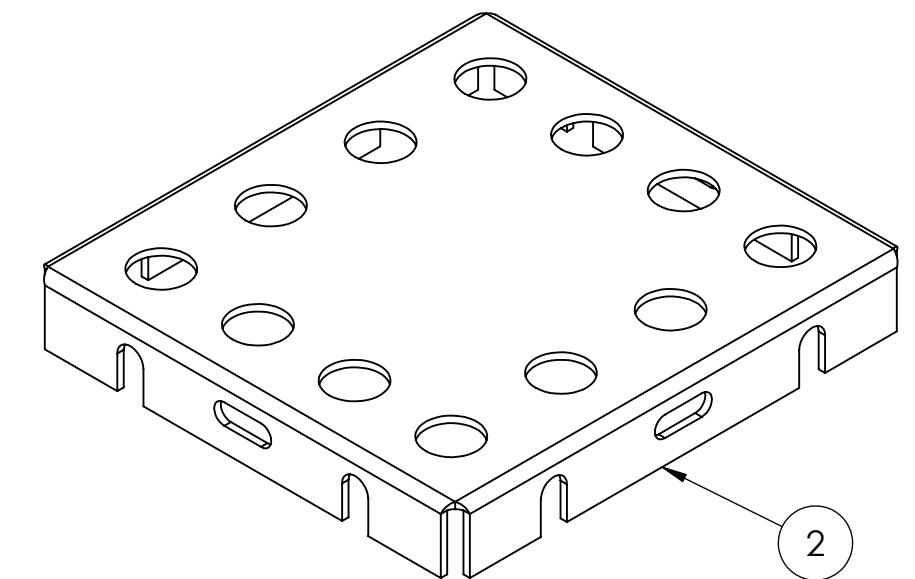
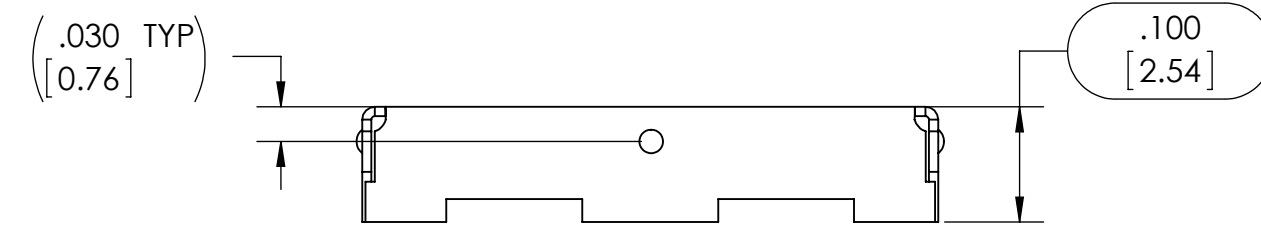
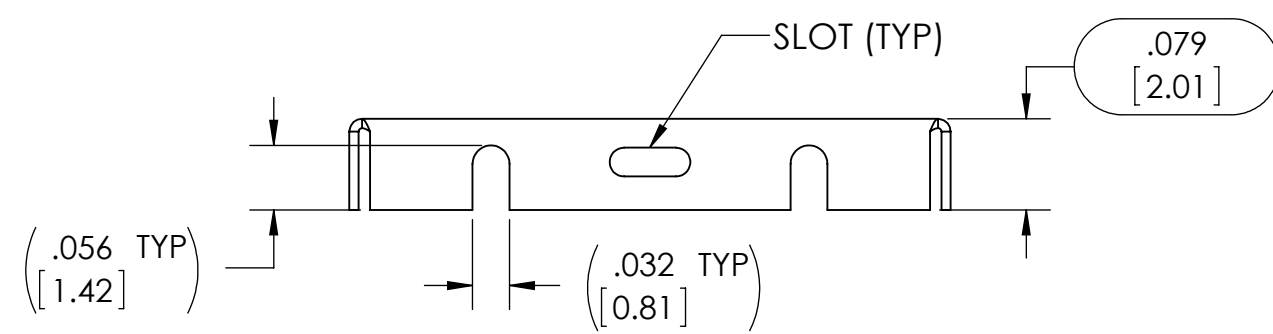
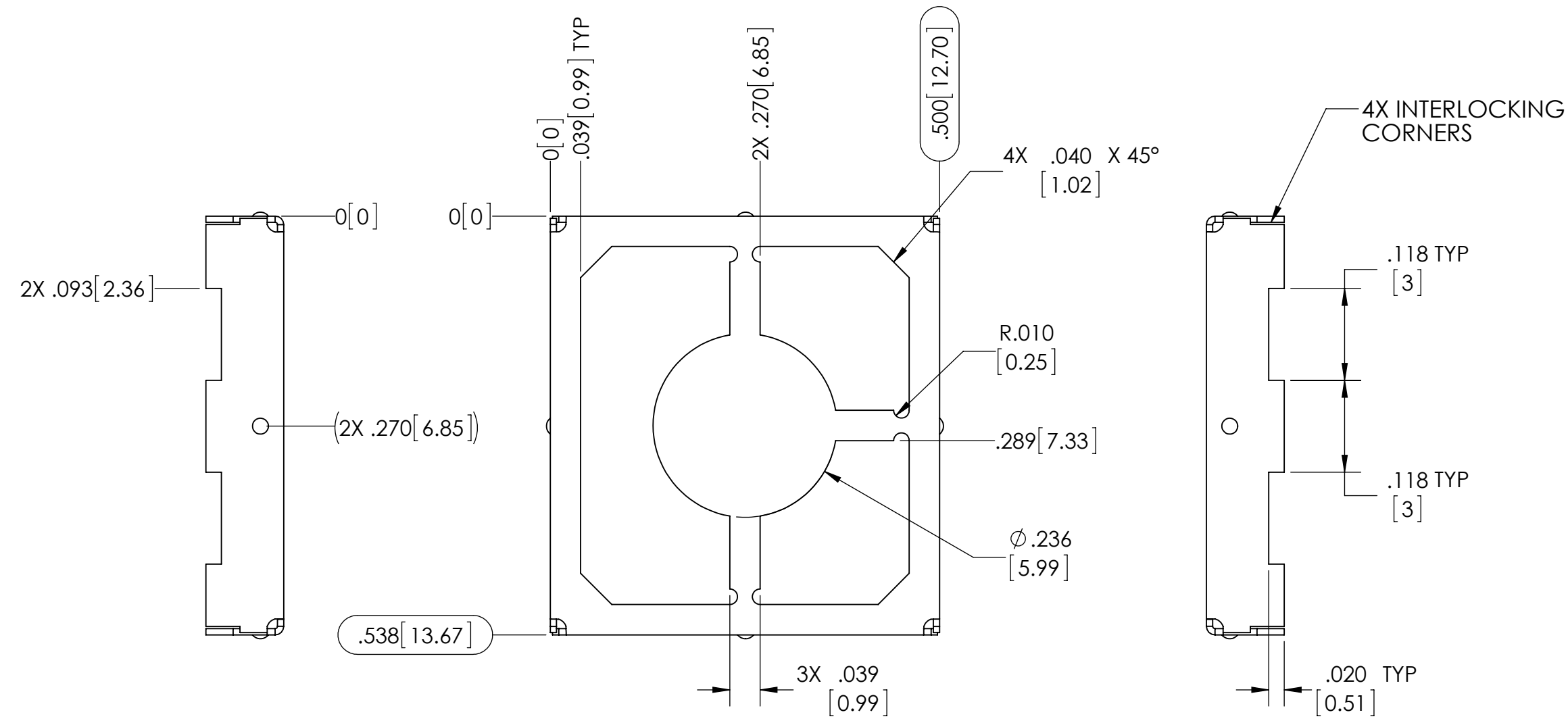
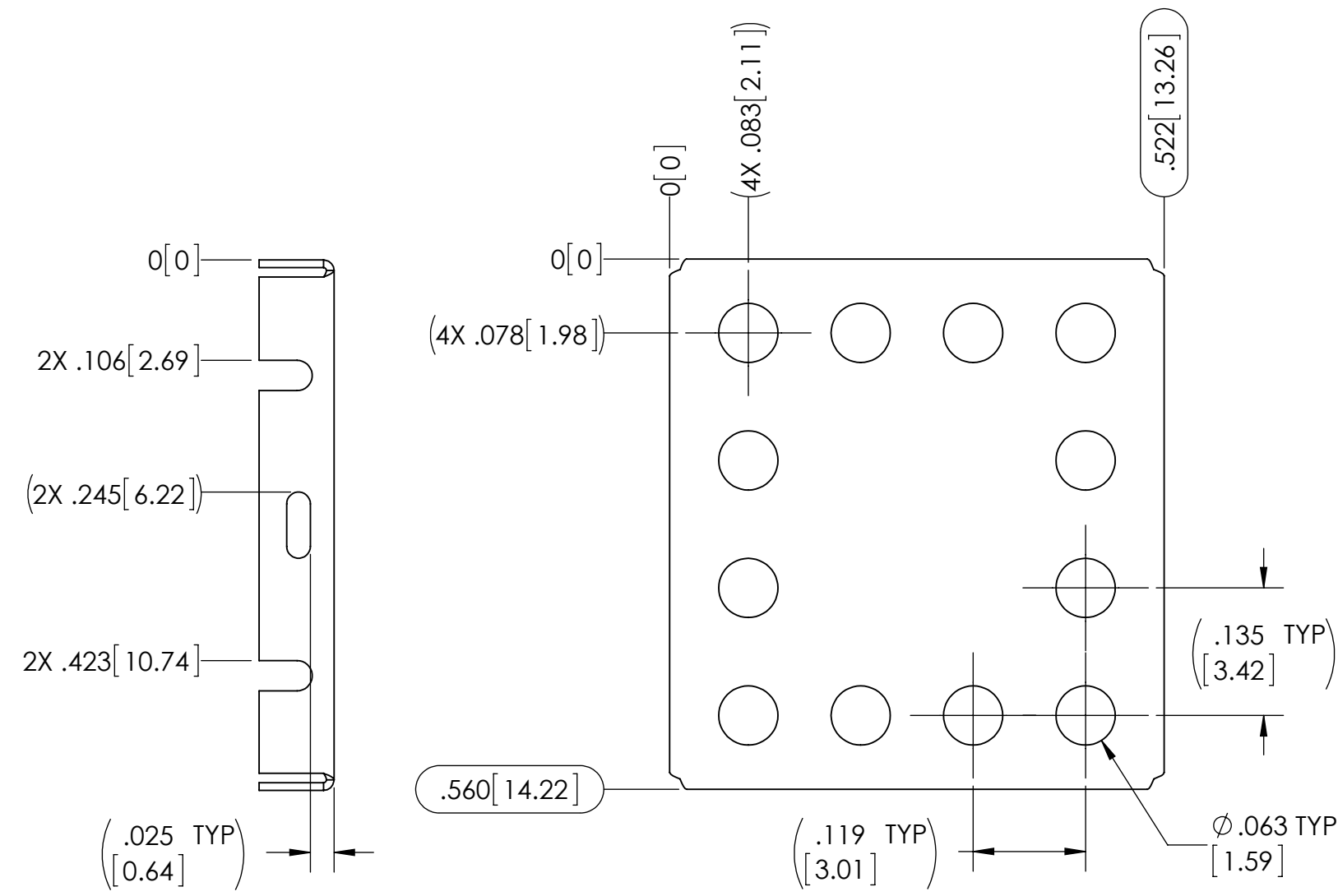
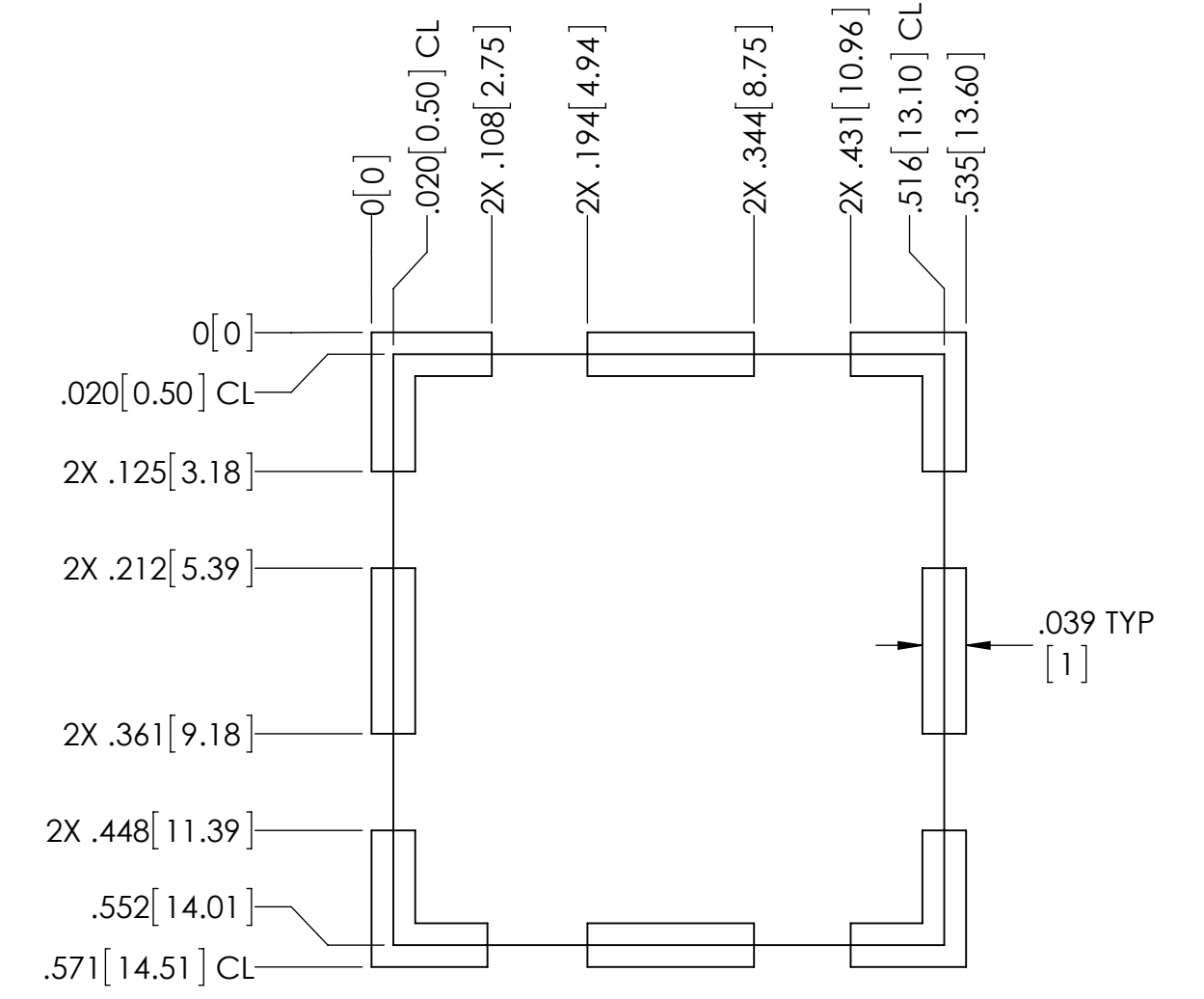
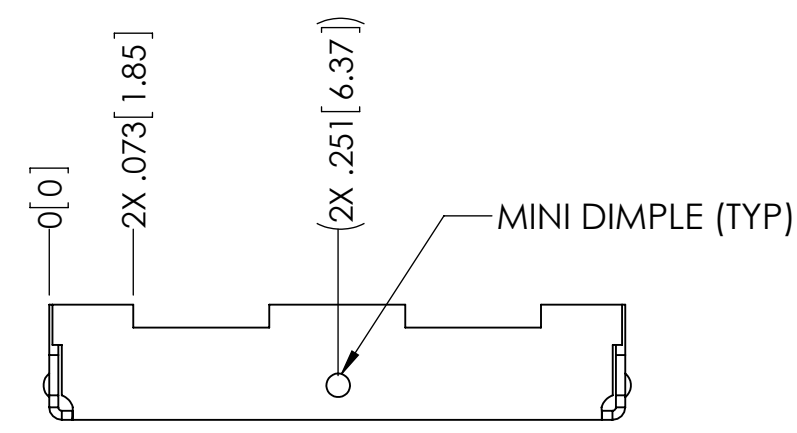
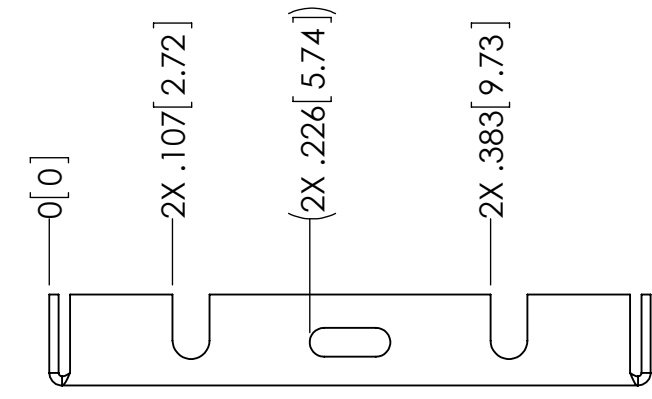

CARRIER TAPE SPECIFICATIONS						
PART NUMBER	DESCRIPTION	OVERALL DIMENSIONS	OVERALL HEIGHT	CARRIER TAPE WIDTH	CARRIER TAPE PITCH	PARTS PER REEL
SMS-201-F	FRAME	.538 X .500 [13.67 X 12.70]	.100 [2.54]	24 mm	20 mm	1000
SMS-201-C	COVER	.560 X .522 [14.22 X 13.26]	.079 [2.01]	N/A	N/A	BULK PACK

THIS DOCUMENT CONTAINS PROPRIETARY INFORMATION OWNED BY LEADTECH OR DEVELOPED AT ITS OWN PRIVATE EXPENSE AND MAY NOT BE USED, DUPLICATED OR DISCLOSED IN WHOLE OR IN PART FOR ANY PURPOSE INCLUDING DESIGN, MANUFACTURE OR PROCUREMENT WITHOUT THE WRITTEN PERMISSION OF LEADTECH. LEADTECH DOES NOT GUARANTEE OR WARRANT THE PERFORMANCE CHARACTERISTICS.

ITEM NO.	PART NUMBER	DESCRIPTION	QTY.
1	SMS-201 F	FRAME	1
2	SMS-201 C	COVER	1

<p>UNLESS OTHERWISE SPECIFIED: - ALL DIMENSIONS ARE IN INCHES - PART SHALL BE FREE OF BURRS AND SHARP EDGES - ALL DIMENSIONS SHOWN APPLY BEFORE PLATING AND COATINGS - ROHS COMPLIANT PER EU DIRECTIVE 2011/65/EU - POI = POINT OF INTERSECTION</p>					
TITLE: SURFACE MOUNT SHIELD		DRAWN BY: DJM 2010-01-06 APPROVED BY: -			
MATERIAL: .008" [0.20] PRE TIN STEEL	SCALE: 6:1	CAGE CODE: 4J674	SHEET: 1 OF 1		