ADuCM410/ADuCM420 Hardware Reference Manual**SCOPE**

This manual provides a detailed description of the ADuCM410 and ADuCM420 functionality and features.

DISCLAIMER

Information furnished by Analog Devices, Inc., is believed to be accurate and reliable. However, no responsibility is assumed by Analog Devices for its use, nor any infringements of patents or other rights of third parties that may result from its use. Specifications subject to change without notice. No license is granted by implication or otherwise under any patent or patent rights of Analog Devices. Trademarks and registered trademarks are the property of their respective owners. See the ADuCM410 and ADuCM420 data sheets for the functional block diagrams.

TABLE OF CONTENTS

Scope.....	1	Other Internal Channels.....	34
Disclaimer.....	1	ADC Calibration.....	34
Using the ADuCM410/ADuCM420 Reference Manual.....	5	ADC Interrupts.....	35
Introduction to the ADuCM410 and ADuCM420....	6	ADC Power-Up Requirements.....	36
Main Features of the ADuCM410 and ADuCM420.....	7	Register Summaries: ADC Control, ADC Voltage Programmable Gain Amplifier (PGA), and ADC Temperature Sensor Registers.....	37
Clocking Architecture.....	8	Register Details ADC Control, ADC Voltage Programmable Gain Amplifier (PGA), and ADC Temperature Sensor Registers.....	38
Clocking Architecture Operation: Switching Clock Settings When PLL Clock Is Included....	8	Voltage References.....	54
PLL Interrupt.....	9	External ADC Reference Details.....	54
Register Summary: Clock Gating and Other Settings (Clock).....	10	Analog Comparators.....	55
Register Details: Clock Gating and Other Settings (Clock).....	10	Analog Comparators Features.....	55
Power Management Unit.....	13	Analog Comparator Overview.....	55
Power Management Unit Features.....	13	Analog Comparator Operation.....	55
Power Management Unit Overview.....	13	Register Summary: Analog Comparators.....	55
Power Management Unit Operation.....	13	Register Details: Analog Comparators.....	55
Register Summary: Power Management Unit.....	14	VDACS.....	61
Register Details: Power Management Unit.....	14	DAC Features.....	61
Arm Cortex-M33 Processor.....	15	DAC Overview.....	61
Arm Cortex-M33 Processor Features.....	15	DAC Operation.....	61
Arm Cortex-M33 Processor Overview.....	15	DAC to Bias Comparator or TIA.....	62
Arm Cortex-M33 Processor Operation.....	15	VDAC Power-Up Requirements.....	62
Arm Cortex-M33 Processor Related Documents.....	16	Register Summary: DAC.....	63
System Exceptions and Peripheral Interrupts....	17	Register Details: DAC.....	63
Cortex-M33 and Fault Management.....	17	Flash Controller.....	64
External Interrupt Configuration.....	21	Flash Controller Features.....	64
Register Summary: External Interrupts.....	22	Flash Controller Overview.....	65
Register Details: External Interrupts.....	22	Flash Protection and Integrity.....	66
Reset.....	24	Flash Controller Performance and Command Duration.....	69
Reset Features.....	24	Flash Erase/Program Requirements.....	69
Reset Operation.....	24	Flash Block Switching.....	69
Register Summary: Reset.....	24	Register Summary: Flash Controller (Flash)....	73
Register Details: Reset.....	25	Register Details: Flash Controller (Flash).....	74
Analog Pin Functionality.....	26	Static Random Access Memory (SRAM).....	83
ADC Circuit.....	27	SRAM Features.....	83
ADC Circuit Features.....	27	SRAM Configuration: Instruction SRAM Vs. Data SRAM.....	83
ADC Circuit Block Diagram.....	27	ECC Protection.....	83
ADC Circuit Overview.....	27	Initialization in Cache and Instruction SRAM...	84
ADC Circuit Operation.....	27	Register Summary: SRAM Controller (SRAM).....	84
ADC Channel Sequencer.....	28	Register Details: SRAM Controller (SRAM)....	84
ADC Transfer Function.....	29	Cache.....	88
ADC Oversampling and Output Data Rate.....	30	Cache Programming Model.....	88
Digital Comparators Overview.....	30	Programming Guidelines.....	88
PGA/TIA Input Amplifier (ADuCM410 Only)....	31		
Temperature Sensor Channel.....	34		

TABLE OF CONTENTS

Register Summary: Cache Controller.....	88	Register Summary: General-Purpose Timers	159
Register Details: Cache Controller.....	88	Register Details: General-Purpose Timers.....	159
I ² C Serial Interfaces.....	90	General-Purpose Timers (32-Bit).....	162
I ² C Features.....	90	Timer Compare Feature.....	162
I ² C Overview.....	90	Timer Capture Feature.....	162
I ² C Operation.....	90	Register Summaries: 32-Bit Timer 0 and 32- Bit Timer 1.....	163
I ² C Operating Modes.....	92	Register Details: 32-Bit Timer 0 and 32-Bit Timer 1.....	163
Register Summaries: I ² C Master/Slave I2C0, I2C1, and I2C2.....	96	Wake-Up Timer.....	166
Register Details: I ² C Master/Slave I2C0, I2C1, and I2C2.....	98	Wake-Up Timer Features.....	166
UART Serial Interface.....	110	Wake-Up Timer Block Diagram.....	166
UART Features.....	110	Wake-Up Timer Overview.....	166
UART Overview.....	110	Wake-Up Timer Operation.....	166
UART Operation.....	110	Register Summary: WUT.....	168
Register Summary: UART0, UART1.....	113	Register Details: WUT.....	169
Register Details: UART0, UART1.....	114	Watchdog Timer.....	173
Serial Peripheral Interfaces.....	123	Watch Dog Timer Features.....	173
SPI Features.....	123	Watchdog Timer Block Diagram.....	173
SPI Overview.....	123	Watch Dog Timer Operation.....	173
SPI Operation.....	123	Windowed Watchdog Feature.....	174
SPI Transfer Initiation.....	124	Interrupt Mode.....	174
SPI Interrupts.....	126	Register Summary: Watchdog Timer Register Map (WDT).....	174
SPI Wire-OR'ed Mode (WOM).....	127	Register Details: Watchdog Timer Register Map (WDT).....	175
SPI CSERR Condition.....	127	Direct Memory Access (DMA) Controller.....	177
SPI DMA.....	127	DMA Features.....	177
SPI and Power-Down Modes.....	128	DMA Overview.....	177
Register Summary: Serial Peripheral Interface (SPI0, SPI1, SPI2).....	128	DMA Operation.....	178
Register Details: Serial Peripheral Interface (SPI0, SPI1, SPI2).....	129	DMA Interrupts.....	178
MDIO.....	138	DMA Priority.....	178
MDIO Features.....	138	Channel Control Data Structure.....	178
MDIO Overview.....	138	Control Data Configuration.....	179
MDIO Operation.....	138	DMA Transfer Types (CHNL_CFG, Bits[2:0]).	181
Register Summary: MDIO Interface.....	140	Address Calculation.....	183
Register Details: MDIO Interface.....	140	PLA Trigger Channel.....	183
Digital Inputs/Outputs.....	144	Aborting DMA Transfers.....	184
Digital Inputs/Outputs Features.....	144	Flash DMA Channel.....	184
Digital Inputs/Outputs Block Diagram.....	144	Register Summary: DMA.....	184
Digital Inputs/Outputs Overview.....	144	Register Summary: DMA Request.....	185
Digital Inputs/Outputs Operation.....	144	Register Details: DMA.....	185
Interrupts.....	146	Register Details: DMA Request.....	192
Digital Port Multiplex.....	147	Programmable Logic Array (PLA).....	195
Register Summary: Digital Input/Output.....	149	PLA Features.....	195
Register Details: Digital Input/Output.....	151	PLA Overview.....	195
General-Purpose Timers (16-Bit).....	158	PLA Operation.....	196
Timer Features and Overview.....	158	Register Summary: PLA.....	197
General-Purpose Timers Operation.....	158	Register Details: PLA.....	198

TABLE OF CONTENTS

Downloader.....	204	Cyclic Redundancy Check.....	213
I ² C Downloader.....	204	CRC Features.....	213
MDIO Downloader.....	204	CRC Functional Description.....	213
Pulse Width Modulator (PWM).....	205	CRC Data Transfer.....	216
PWM Features.....	205	CRC Programming Model.....	216
PWM Overview.....	205	Register Summary: CRC.....	217
PWM Operation.....	205	Register Details: CRC.....	217
PWM Interrupt Generation.....	208	Silicon Identification.....	219
Register Summary: PWM.....	208	Register Summary: Silicon Identification.....	219
Register Details: PWM.....	209	Register Details: Silicon Identification.....	219

REVISION HISTORY**6/2023—Rev. 0 to Rev. A**

Changes to Figure 1.....	8
Changes to Table 65.....	55
Changes to Table 66.....	56
Changes to Table 67.....	58
Changes to Table 68.....	59
Changes to Automatic Clock Stretching Section.....	93
Changes to Table 228.....	160
Changes to Figure 32, Figure 33, and Figure 34.....	195
Changes to Table 303.....	199

1/2021—Revision 0: Initial Version

USING THE ADUCM410/ADUCM420 REFERENCE MANUAL**Table 1. Number Notations**

Notation	Description
Bit N	Bits are numbered in little endian format, where the least significant bit of a number is referred to as Bit 0.
V[x:y]	A range from Bit x to Bit y of a value or a field (V) is represented in bit field format V[x:y].
0xNN	Hexadecimal (Base 16) numbers are preceded by the 0x prefix.
0bNN	Binary (Base 2) numbers are preceded by the 0b prefix.

Table 2. Register Access Conventions

Mode	Description
R/W	Memory location has read and write access.
RC	Memory location is cleared after reading it.
R	Memory location is read access only. A read always returns 0, unless otherwise specified.
W	Memory location is write access only.
R/W1C	Memory location has read access. To clear to 0, write 1 once to the memory location.

Memory mapped register (MMR) bits that are not documented are reserved. When writing to MMRs with reserved bits, the reserved bits must be written with the value in the reset column of the relevant MMR description, unless otherwise specified.

INTRODUCTION TO THE ADUCM410 AND ADUCM420

The ADuCM410 and ADuCM420 are fully integrated, single package devices that include high performance analog peripherals together with digital peripherals (controlled by a 160 MHz Arm® Cortex®-M33 processor) and integrated flash for code and data.

The analog-to-digital converter (ADC) on the devices provides 16-bit (ADuCM410) and 12-bit (ADuCM420), 2 MSPS data acquisition using up to 16 input pins that can be programmed for single-ended or differential operation with a programmable gain amplifier (PGA) or transimpedance amplifier (TIA) for voltage and current measurements. Additionally, the die temperature and supply voltages can be measured.

The ADC input voltage is 0 V to VREF. A sequencer is provided that allows a user to select a set of ADC channels to be measured in sequence without software involvement during the sequence. The sequence can optionally repeat automatically at a user-selectable rate.

Up to 12 channels of 12-bit voltage digital-to-analog converters (VDACs) are provided with output buffers supported.

The ADuCM410 and ADuCM420 can be configured so that the digital and analog outputs retain their output voltages through a watchdog or software reset sequence. Therefore, a product can remain functional even while the ADuCM410 or ADuCM420 is resetting itself.

The ADuCM410 and ADuCM420 have a low power Arm Cortex-M33 processor and a 32-bit reduced instruction set computer (RISC) machine that offers up to 240 million instructions per second (MIPS) peak performance with a floating-point unit (FPU). Also integrated are 2× 512 kB Flash/EE memories and 128 kB static random access memory (SRAM)—both with single-error correction (SEC) and double error detection (DED) error checking and correction (ECC). The flash comprises two separate 512 kB blocks supporting execution from one flash block and simultaneous writing and/or erasing of the other flash block.

The ADuCM410 and ADuCM420 operate from an on-chip oscillator and have a phase-locked loop (PLL) of 160 MHz. This clock can optionally be divided down to reduce current consumption. Additional low power modes can be set via the ADuCM410 and ADuCM420 software.

The device includes a management data input/output (MDIO) interface capable of operating up to 10 MHz. User programming is eased by incorporating physical address (PHYADR) and device address (DEVADD) hardware comparators. The nonerasable kernel code combined with flags in user flash allow user code to reliably switch between the two hardware independent flash blocks.

The ADuCM410 and ADuCM420 integrate a range of on-chip peripherals that can be configured under software control, as required in the application. These peripherals include two universal asynchronous receiver transmitters (UARTs), three I²C and three serial peripheral interface (SPI) serial input/output communication controllers, general-purpose inputs/outputs (GPIOs), a 32-element programmable logic array (PLA), five general-purpose timers, a wake-up timer (WUT), and a system watchdog timer (WDT). A 16-bit pulse-width modulation (PWM) with eight output channels is also provided.

The GPIO pins (Px.x) power up in high impedance input mode. In output mode, the software chooses between open-drain mode and push/pull mode. The pull-up and pull-down resistors can be disabled and enabled in the software. The GPIO pins can be configured with different voltage levels according to the IOVDDx pin, such as 3.3 V, 1.8 V, and 1.2 V. In GPIO output mode, the inputs can remain enabled to monitor the GPIO pins. The GPIO pins can also be programmed to handle digital or analog peripheral signals, in which case, the pin characteristics are matched to the specific requirement.

A large support ecosystem is available for the Arm Cortex-M33 processor to ease product development of the ADuCM410 and ADuCM420. Access is via the Arm serial wire debug port. On-chip factory firmware supports in-circuit serial download via MDIO or I²C. These features are incorporated into a low cost, quick start development system supporting this precision analog microcontroller.

Note that throughout this user guide, multifunction pins, such as P2.3/BM/PLA10, are referred to either by the entire pin name or by a single function of the pin, for example, P2.3, when only that function is relevant.

INTRODUCTION TO THE ADUCM410 AND ADUCM420

MAIN FEATURES OF THE ADUCM410 AND ADUCM420

The analog-to-digital converter (ADC) includes the following features:

- ▶ Multichannel, 16-bit, 2 MSPS SAR ADC with 16-bit no missing codes (ADuCM410) or 12-bit no missing codes (ADuCM420)
- ▶ Low drift, on-chip voltage reference
- ▶ Voltage and current input measurements supported, including PGA with programmable gain setting (ADuCM410) and TIAs with programmable gain resistors (ADuCM410)

The digital-to-analog converters (DACs) include the following features:

- ▶ 12 VDACS that are 12-bit monotonic
- ▶ Low drift, on-chip 2.5 V voltage reference source with two buffered reference outputs

The ADuCM410 and ADuCM420 include four comparators with configurable hysteresis levels.

The ADuCM410 and ADuCM420 contain the following communication features:

- ▶ Two UART channels with industry-standard, 16450 UART peripheral and support for direct memory access (DMA).
- ▶ Three I²C channels with 2-byte transmit and receive first in, first out (FIFO) buffers for the master and slave, support for DMA, an automatic clock stretching option, and support for 3.4 Mbps, 1 Mbps, 400 kbps, and 100 kbps.
- ▶ Three SPIs with master or slave mode, separate 4-byte receive and transmit FIFOs, and receive and transmit DMA channels.
- ▶ MDIO slave at up to 10 Mbps.
- ▶ 16-bit, 8-channel PWM.
- ▶ 12 GPIO pins with configurable input/output (I/O) level (3.3 V or 1.8 V).

The processor operates using the following:

- ▶ Arm Cortex-M33 processor operating from an internal 160 MHz system clock
- ▶ 1 MB Flash/EE memory, 128 kB SRAM (ADuCM410) or 512 kB Flash/EE memory, 64 kB SRAM (ADuCM420)
- ▶ In-circuit download and debug via serial wire
- ▶ On-chip I²C or MDIO download capability

The on-chip peripherals include the following:

- ▶ Five general-purpose timers
- ▶ Wake-up timer
- ▶ Watchdog timer
- ▶ 32-element PLA

The ADuCM410 and ADuCM420 are packaged in a 5 mm × 5 mm, 81-ball CSP_BGA package and 3.46 mm × 3.46 mm 64-ball WLCSP. The temperature range is -40°C to +105°C.

The ADuCM410 and ADuCM420 offer a low cost development system and third-party compiler and emulator tool support. The devices can be used in optical networking applications, such as 100 Gbps, 200 Gbps, and 400 Gbps optical transceivers.

CLOCKING ARCHITECTURE

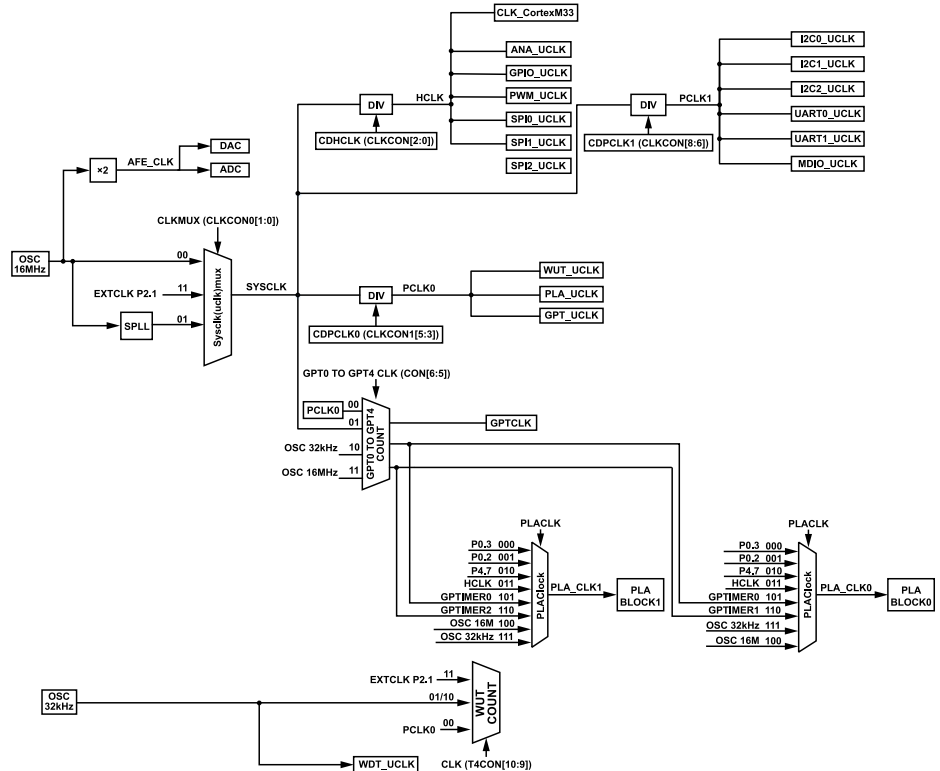

Figure 1. Clock Architecture Overview

CLOCKING ARCHITECTURE OPERATION: SWITCHING CLOCK SETTINGS WHEN PLL CLOCK IS INCLUDED

When the PLL is the source clock for any ADuCM410 and ADuCM420 block, follow these steps to change the clock divide ratio:

1. Set the internal oscillator as the source clock.
2. Configure the required clock divide coefficient.
3. Set PLL as the root clock again.

CLOCKING ARCHITECTURE

PLL INTERRUPT

Analog Devices recommends the user always enable the PLL interrupt source for the unlikely event that a PLL loss of lock error occurs. If the PLL loses lock, the risk of a system error is high, which may result in a hard fault or bus fault exception occurring.

The ADuCM410 and ADuCM420 PLL interrupt source triggers on the loss of lock. In this interrupt handler function, Analog Devices recommends first switching the system clock to the internal oscillator source. Then user code can recover as required, possibly via a software reset or alerting a host to a hardware error on the ADuCM410 and ADuCM420.

After a reset, the internal kernel program enables and selects the kernel as the high speed system clock (HCLK) source. Therefore, the first read of the CLKSTAT0 register likely shows both the SPLLOCK and SPLUNLOCK bits set. Before enabling the PLL interrupt source, clear these bits by writing 1 to the SPLLOCKCLR and SPLUNLOCKCLR bits of CLKSTAT0.

The following is example code to enable the PLL interrupts, and shows an example interrupt service routine:

```
pADI_CLK->CLKCON0 |=
    BITM_CLOCK_CLKCON0_SPLLIE;           // Enable PLL interrupts
NVIC_EnableIRQ(PLL_IRQn);               // Enable PLL detection interrupt

void PLL_Int_Handler()
{
    uint32_t ulPLLSTA = 0;

    ulPLLSTA = pADI_CLK->CLKSTAT0;
    if ((ulPLLSTA & BITM_CLOCK_CLKSTAT0_SPLLUNLOCK)
        == BITM_CLOCK_CLKSTAT0_SPLLUNLOCK) // PLL loss of lock error detected
    {
        // Change CPU clock source to Internal Oscillator
        pADI_CLK->CLKCON0 &= 0xFFFC;        // Return to internal oscillator - PLL unstable
        ucPLLLoss = 1;                     // Set flag to indicate loss of PLL Lock error
    }
    if ((ulPLLSTA & BITM_CLOCK_CLKSTAT0_SPLLLOCK)
        == BITM_CLOCK_CLKSTAT0_SPLLLOCK) // PLL lock detected
    {
        // Change CPU clock source to PLL - PLL is stable
        pADI_CLK->CLKCON0 &= 0xFFFC;
        pADI_CLK->CLKCON0 |= 0x1;          // PLL is stable
        ucPLLLoss = 0;                     // Set flag to indicate loss of PLL Lock error
    }
    pADI_CLK->CLKSTAT0 |=
        BITM_CLOCK_CLKSTAT0_SPLLLOCKCLR |
        BITM_CLOCK_CLKSTAT0_SPLLUNLOCKCLR;
}
```

CLOCKING ARCHITECTURE

REGISTER SUMMARY: CLOCK GATING AND OTHER SETTINGS (CLOCK)

Table 3. Clock Register Summary

Address	Name	Description	Reset	Access
0x40060000	CLKCON0	Miscellaneous Clock Settings Register.	0x043D	R/W
0x40060004	CLKCON1	Clock Dividers Register.	0x0048	R/W
0x40060008	CLKSTAT0	Clock Status Register.	0x0019	R/W

REGISTER DETAILS: CLOCK GATING AND OTHER SETTINGS (CLOCK)

Miscellaneous Clock Settings Register

Address: 0x40060000, Reset: 0x043D, Name: CLKCON0

CLKCON0 is used to configure clock sources used by various blocks such as the core and memories as well as peripherals. All unused bits are read only, returning a value of 0.

Table 4. Bit Descriptions for CLKCON0

Bits	Bit Name	Settings	Description	Reset	Access
[15:12]	RESERVED		Reserved.	0x0	R
[11:10]	ANAROOTCLKMUX	00 Reserved. 01 32 MHz Oscillator Clock. Only option allowed. 10 Reserved. 11 Reserved.	Clock Mux Select for ADC and DAC Blocks.	0x1	R/W
9	SPLLIE	0 PLL Interrupt Is Not Generated. 1 PLL Interrupt Is Generated.	PLL Unlock and Lock Interrupt Enable. If this bit is enabled, an interrupt is generated if the PLL transits from lock to unlock or from unlock to lock.	0x0	R/W
[8:6]	RESERVED		Reserved.	0x0	R/W
[5:2]	CLKOUT	0000 16 MHz Internal High Frequency Oscillator. 0001 HCLK. 0010 Reserved. 0011 32 kHz Internal Oscillator. 0100 HCLK. 0101 Peripheral Clock 0 (PCLK0). 0110 Peripheral Clock 1 (PCLK1). 0111 Reserved. 1000 Reserved. 1001 Timer 0 Clock. 1010 Wake-Up Timer Clock. 1011 Timer 3 Clock. 1100 HCLK. 1101 SPLL Clock. 1110, 1111 Reserved.	GPIO Clock Output Select. Used to select which clock is output on GPIO pin (P2.2). Implemented as a 16 to 1 mux.	0xF	R/W
[1:0]	CLKMUX	00 High Frequency Internal Oscillator. 01 System PLL is Selected (160 MHz). 10 Reserved. 11 External GPIO Port is Selected (ECLKIN on P2.1).	Clock Mux Select. Determines HCLK clock source.	0x1	R/W

CLOCKING ARCHITECTURE

Clock Dividers Register

Address: 0x40060004, Reset: 0x0048, Name: CLKCON1

CLKCON1 is used to set the divide rates for the universal clock (UCLK) and PCLK0/PCLK1. This register can be written at any time. All unused bits are read only, returning a value of 0. Writing unused bits has no effect.

Analog Devices only guarantees operation for clock divider settings of $\div 1$, $\div 2$, $\div 4$, and $\div 8$.

Table 5. Bit Descriptions for CLKCON1

Bits	Bit Name	Settings	Description	Reset	Access
[15:9]	RESERVED		Reserved.	0x00	R
[8:6]	CDPCLK1	000 Divide by 1 (PCLK1 is Equal to Root Clock). 001 Divide by 2 (PCLK1 is Half the Frequency of Root Clock). 010 Divide by 4 (PCLK1 is Quarter the Frequency of Root Clock, 40 MHz). 011 Divide by 8. 100 Divide by 16. Reserved. Analog Devices has not characterized for this clock divide setting. 101 Divide by 32. Reserved. Analog Devices has not characterized for this clock divide setting. 110 Divide by 64. Reserved. Analog Devices has not characterized for this clock divide setting. 111 Divide by 128. Reserved. Analog Devices has not characterized for this clock divide setting.	PCLK1 Divide Bits. PCLK1 must be \leq HCLK.	0x1	R/W
[5:3]	CDPCLK0	000 Divide by 1 (PCLK0 is Equal to Root Clock). 001 Divide by 2 (PCLK0 is Half the Frequency of Root Clock). 010 Divide by 4 (PCLK0 is Quarter the Frequency of Root Clock, 40 MHz). 011 Divide by 8. 100 Divide by 16. Reserved. Analog Devices has not characterized for this clock divide setting. 101 Divide by 32. Reserved. Analog Devices has not characterized for this clock divide setting. 110 Divide by 64. Reserved. Analog Devices has not characterized for this clock divide setting. 111 Divide by 128. Reserved. Analog Devices has not characterized for this clock divide setting.	PCLK0 Divide Bits. PCLK0 must be \leq HCLK.	0x1	R/W
[2:0]	CDHCLK	000 Divide by 1 (HCLK is Equal to Root Clock). 001 Divide by 2 (HCLK is Half the Frequency of Root Clock). 010 Divide by 4 (HCLK is Quarter the Frequency of Root Clock). 011 Divide by 8. 100 Divide by 16. Reserved. Analog Devices has not characterized for this clock divide setting. 101 Divide by 32. Reserved. Analog Devices has not characterized for this clock divide setting. 110 Divide by 64. Reserved. Analog Devices has not characterized for this clock divide setting. 111 Divide by 128. Reserved. Analog Devices has not characterized for this clock divide setting.	HCLK Divide Bits. HCLK must be \geq PCLKx.	0x0	R/W

CLOCKING ARCHITECTURE

Clock Status Register

Address: 0x40060008, Reset: 0x0019, Name: CLKSTAT0

CLKSTAT0 is used to monitor the PLL and oscillator status. With interrupts enabled, the user is free to run initialization code or idle the core while clock components stabilize.

Table 6. Bit Descriptions for CLKSTAT0

Bits	Bit Name	Settings	Description	Reset	Access
[15:5]	RESERVED		Reserved.	0x0	R
4	SPLLUNLOCK		System PLL Unlock Flag. 0 No PLL Unlock Event Was Detected. 1 A PLL Unlock Event Was Detected. Cleared by writing a 1 to SPLLUNLOCKCLR.	0x1	R
3	SPLLLOCK		System PLL Lock Flag. 0 No PLL Lock Event Was Detected. 1 A PLL Lock Event Was Detected. Cleared by writing a 1 to SPLLLOCKCLR.	0x1	R
2	SPLLUNLOCKCLR		System PLL Unlock. Writing a 1 to this bit clears the SPLLUNLOCK bit.	0x0	R/W
1	SPLLLOCKCLR		System PLL Lock. Writing a 1 to this bit clears sticky status and SPLLLOCK status bit.	0x0	R/W
0	SPLLSTATUS		System PLL Status. Indicates the current status of the PLL. Initially, the system PLL is unlocked. After a stabilization period, the PLL locks and is ready for use as the system clock source. This is a read only bit. A write has no effect. 0 The PLL Is Not Locked or Not Properly Configured. The PLL is not ready for use as the system clock source. 1 The PLL Is Locked and Is Ready for Use as the System Clock Source.	0x1	R

POWER MANAGEMENT UNIT

POWER MANAGEMENT UNIT FEATURES

The power management unit (PMU) controls the different power modes of the ADuCM410 and ADuCM420.

Four power modes are available: active, core sleep, system sleep, and hibernate.

POWER MANAGEMENT UNIT OVERVIEW

The Cortex-M33 power saving modes are linked to the PMU modes and are described in this section. The PMU is in the always on section. Each mode gives a power reduction benefit with a corresponding reduction in functionality.

POWER MANAGEMENT UNIT OPERATION

The debug tools can prevent the Cortex-M33 from fully entering its power saving modes by setting bits in the debug logic. Only a power-on reset resets the debug logic. Therefore, the device must be power cycled after using serial wire debug with application code containing the wait for interrupt (WFI) instruction.

Power Mode: Active Mode (Mode 0)

The system is fully active. Memories and all user enabled peripherals are clocked, and the Cortex-M33 processor executes instructions. Note that the Cortex-M33 processor manages its internal clocks and can be in a partial clock gated state. This clock gating affects only the internal Cortex-M33 processing core. Automatic clock gating is used on all blocks. User code can use a WFI command to put the Cortex-M33 processor into a power saving mode (Mode 1, Mode 2, or Mode 3). The WFI instruction is independent of the power mode settings of the PMU.

When the ADuCM410 and ADuCM420 wake up from any of the low power modes (Mode 1 to Mode 3), the devices return to Mode 0.

Power Mode: Core Sleep Mode (Mode 1)

In core sleep mode, the system gates the clock to the Cortex-M33 core after the Cortex-M33 enters sleep mode. The rest of the system remains active. No instructions can be executed. However, DMA transfers can continue to occur between peripherals and memories. The Cortex-M33 processor HCLK is active, and the device wakes up using the nested vectored interrupt controller (NVIC).

Power Mode: System Sleep Mode (Mode 2)

In system sleep mode, the system gates the high speed system bus clock (HCLK) and the peripheral bus clocks (PCLK0 and PCLK1) after the Cortex-M33 enters sleep mode. The gating of these clocks stops all Arm high performance bus (AHB) activities and all peripherals attached to the Arm peripheral bus (APB). Peripheral clocks are all off, and they are no longer user programmable. The NVIC clock remains active, and the NVIC processes wake-up events.

Power Mode : Hibernate Mode (Mode 3)

In hibernate mode, the system disables power to all combinational logic and places sequential logic in retain mode. Because HCLK is stopped, the number of sources capable of waking up the system is restricted. A limited number of interrupts can wake the device from this mode (see [Table 11](#)).

Power Mode 1 to Power Mode 3 must be entered when the processor is not in an interrupt handler. If Power Mode 1 to Power Mode 3 are entered when the processor is in an interrupt handler, the power-down mode can only be exited by a reset or a higher priority interrupt source.

The following is example code of how to enter hibernate mode:

```
void EnterHibernateMode(void)
{
    int32_t index = 0;

    SCB->SCR = 0x04;           // sleep deep mode - write to the Cortex-M33 System
    Control register bit2
    pADI_ALLON->PWRKEY = 0x4859; // key1
    pADI_ALLON->PWRKEY = 0xF27B; // key2
    pADI_ALLON->PWRMOD = 0x3;    // Hibernate state
}
```

POWER MANAGEMENT UNIT

```

pADI_ALLON->PWRKEY = 0x4859;    // key1
pADI_ALLON->PWRKEY = 0xF27B;    // key2
pADI_ALLON->PWRMOD |= 0x8;      // Deep sleep - not required when entering Core
Sleep mode

for (index=0;index<2;index++);
  _WFI();
for (index=0;index<2;index++);
}

```

REGISTER SUMMARY: POWER MANAGEMENT UNIT*Table 7. Power Management Register Summary*

Address	Name	Description	Reset	Access
0x40005000	PWRMOD	Power modes	0x0000	RW
0x40005004	PWRKEY	Key protection for PWRMOD	0x0000	RW

REGISTER DETAILS: POWER MANAGEMENT UNIT**Power Modes Register**

Address: 0x40005000, Reset: 0x0000, Name: PWRMOD

Table 8. Bit Descriptions for PWRMOD

Bits	Bit Name	Settings	Description	Reset	Access
[15:4]	RESERVED		Reserved.	0x0	R
3	WICENACK		Wake-Up Controller Acknowledgment for Hibernate Mode (Mode 3).	0x0	R
		0	Disable Sleep Deep.		
		1	Enable Sleep Deep. Must be set to enter system sleep and hibernate modes.		
2	RESERVED		Reserved.	0x0	R
[1:0]	PWRMOD		Power Modes Control Bits. When read, these bits contain the last power mode value entered by user code. Note that, to place the Cortex in hibernate mode (Mode 3), the Cortex-M33 System Control Register (Address 0xE000ED10) must be configured to 0x4 or 0x06.	0x0	R/W
		00	Active Mode.		
		01	Core Sleep Mode.		
		10	System Sleep Mode.		
		11	Hibernate Mode.		

Key Protection for PWRMOD Register

Address: 0x40005004, Reset: 0x0000, Name: PWRKEY

Table 9. Bit Descriptions for PWRKEY

Bit(s)	Bit Name	Description	Reset	Access
[15:0]	PWRKEY	Power control key register. The PWRMOD register is key protected. Two writes to the key are necessary to change the value in the PWRMOD register: first 0x4859, then 0xF27B. Then, write to the PWRMOD register. A write to any other register before writing to PWRMOD returns the protection to the lock state.	0x0	RW

ARM CORTEX-M33 PROCESSOR

ARM CORTEX-M33 PROCESSOR FEATURES

The high performance features include the following:

- ▶ 1.5 Dhrystone MIPS/MHz.
- ▶ Many instructions, including multiply, are single cycle.
- ▶ Optimized for single-cycle flash usage.
- ▶ Hardware division and fast digital signal processing (DSP) orientated multiply and accumulate.

The low power features include the following:

- ▶ Low standby current.
- ▶ Core implemented using advanced clock gating so that only the actively used logic consumes dynamic power.
- ▶ Low power features including architectural clock gating, sleep mode, and a power aware system with optional wake-up interrupt controller.

The advanced interrupt handling features include the following:

- ▶ The NVIC supports up to 480 interrupts, and eight levels of priority are available. The ADuCM410 and ADuCM420 support 74 of these interrupts. The vectored interrupt feature greatly reduces interrupt latency because software is not required to determine which interrupt handler to serve. In addition, software is not required to set up nested interrupt support.
- ▶ The Arm Cortex-M33 processor automatically pushes registers onto the stack at the entry interrupt and retrieves them at the exit interrupt. The pushing and retrieving reduce interrupt handling latency and allow interrupt handlers to be normal C functions.
- ▶ Dynamic priority control for each interrupt.
- ▶ Latency reduction using late arrival interrupt acceptance and tail chain interrupt entry.
- ▶ Immediate execution of a nonmaskable interrupt request for safety critical applications.

The system includes advanced fault handling features, including various exception types and fault status registers.

The ADuCM410 and ADuCM420 also have the following debug support features:

- ▶ Serial wire debug (SWD) interfaces.
- ▶ Flash patch and breakpoint unit for implementing breakpoints.
- ▶ Data watchpoint and trigger unit for implementing watchpoints trigger resources and system profiling. The ADuCM410 and ADuCM420 are limited to one hardware watchpoint. With only one comparator, the data watchpoint and trigger unit does not support data matching for watchpoint generation.

ARM CORTEX-M33 PROCESSOR OVERVIEW

The ADuCM410 and ADuCM420 contain an embedded Arm Cortex-M33 processor. The Arm Cortex-M33 processor provides a high performance, low cost platform that meets the system requirements of minimal memory implementation, reduced pin count, and low power consumption while delivering computational performance and system response to interrupts.

ARM CORTEX-M33 PROCESSOR OPERATION

Several Arm Cortex-M33 processor components are flexible in their implementation. This section details the actual implementation of these components in the ADuCM410 and ADuCM420.

Serial Wire Debug

The ADuCM410 and ADuCM420 support the serial wire interface via SWO, SWCLK, and SWDIO. The devices do not support the 5-wire Joint Action Test Group (JTAG) interface.

ROM Table

The ADuCM410 and ADuCM420 implement the default read only memory (ROM) table.

ARM CORTEX-M33 PROCESSOR

Nested Vectored Interrupt Controller Interrupts (NVICs)

The Arm Cortex-M33 processor includes an NVIC, which offers the following features:

- ▶ Nested interrupt support
- ▶ Vectored interrupt support
- ▶ Dynamic priority changes support
- ▶ Interrupt masking

In addition, the NVIC has a nonmaskable interrupt (NMI) input.

The NVIC is implemented on the ADuCM410 and ADuCM420, and more details are available in the [System Exceptions and Peripheral Interrupts](#) section.

Wake-Up Interrupt Controller

The ADuCM410 and ADuCM420 have a modified wake-up controller that provides the lowest possible power-down current. More details on this feature are available in the [Power Management Unit](#) section. It is not recommended to enter power saving mode while servicing an interrupt. However, if the device does enter power saving mode while servicing an interrupt, it can only wake up by a higher priority interrupt source.

μDMA

The ADuCM410 and ADuCM420 implement the Arm μDMA. See the [Direct Memory Access \(DMA\) Controller](#) section for more details.

Floating-Point Unit (FPU)

The Cortex-M33 contains a single precision, floating-point computation unit.

The FPU adds 45 IEEE® 754™-2008-compatible, single-precision floating-point instructions. Using floating-point instructions usually yields an average of 10 times increase in performance over the equivalent software libraries.

Ensure the compiler is instructed to use the FPU for floating-point arithmetic (see the ADuCM410 and ADuCM420 evaluation kits for examples).

Peripheral Address Accesses Using a Cortex-M33 Core

Unaligned peripheral address accesses are not supported on the Cortex-M33 core. Unaligned address accesses result in a usage exception fault. Access for a Cortex-M33 core is different compared to a Cortex-M3, which does not generate such an exception for unaligned address accesses.

An example code of an unaligned memory access follows:

```
R0 = 4
R1 = 0x40064001
STR R0, [R1]
```

When R1 = 0x20001001(SRAM location), there is no issue.

When R1 = 0x40064001, which is the PWMCON0 Byte 1 address, a usage fault exception occurs.

If using the C-based header file definitions provided with the Analog Devices evaluation software, the usage fault errors are not a concern.

ARM CORTEX-M33 PROCESSOR RELATED DOCUMENTS

The following list contains documentation related to the Arm Cortex-M3:

- ▶ Cortex-M33 Revision r1p0 Technical Reference Manual.
- ▶ ARMv8-M Architecture Reference Manual (DDI 0553).
- ▶ Arm Debug Interface Architecture Specification v5.
- ▶ PrimeCell μDMA Controller (PL230) Technical Reference Manual Revision r0p0 (DDI 0417).

SYSTEM EXCEPTIONS AND PERIPHERAL INTERRUPTS

CORTEX-M33 AND FAULT MANAGEMENT

The ADuCM410 and ADuCM420 integrate an Arm Cortex-M33 processor, which supports several system exceptions and interrupts generated by peripherals. [Table 10](#) lists the Arm Cortex-M33 processor system exceptions.

Table 10. System Exceptions

Number	Type	Priority	Description
1	Reset	-3 (highest)	Any reset.
2	NMI	-2	Nonmaskable interrupt not connected on the ADuCM410 and ADuCM420.
3	Hard fault	-1	All fault conditions if the corresponding fault handler is not enabled.
4	Memory management fault	Programmable	Access to invalid locations.
5	Bus fault	Programmable	Prefetch fault, memory access fault, data abort, and other address/memory related faults.
6	Usage fault	Programmable	Same as undefined instruction executed or invalid state transition attempt.
7 to 10	Reserved	Not applicable.	Not applicable.
11	SVCALL	Programmable	System supervisor call with SVC instruction. Used for system function calls.
12	Debug monitor	Programmable	Debug monitor (breakpoint, watchpoint, or external debug requests).
13	Reserved	Not applicable	Not applicable.
14	PENDSV	Programmable	Pending request for system service. Used for queuing system calls until other tasks and interrupts are serviced.
15	SYSTICK	Programmable	System tick timer.

The NVIC controls the peripheral interrupts and are listed in [Table 11](#). All interrupt sources can wake up the device from core sleep mode (Mode 1). Only a limited number of interrupts can wake up the processor from the low power modes, system sleep and hibernate (Mode 2 and Mode 3), as shown in [Table 11](#). When the device is woken up from Mode 2 or Mode 3, it returns to Mode 0. If the processor enters any power mode from Mode 1 to Mode 3 while the processor is in an interrupt handler, only an interrupt source with a higher priority than the current interrupt can wake up the device (higher value in the IPRx registers).

The following two steps are usually required to configure an interrupt:

1. Configure a peripheral to generate an interrupt request to the NVIC.
2. Configure the NVIC for that peripheral request.

Table 11. Interrupt Vector Table

Interrupt Number	Vector	Wake Up Processor from Mode 1	Wake Up Processor from Mode 2 or Mode 3
0	Wake-up timer	Yes	Yes
1	External Interrupt 0	Yes	Yes
2	External Interrupt 1	Yes	Yes
3	External Interrupt 2	Yes	Yes
4	External Interrupt 3	Yes	Yes
5	External Interrupt 4	Yes	Yes
6	External Interrupt 5	Yes	Yes
7	External Interrupt 6	Yes	Yes
8	External Interrupt 7	Yes	Yes
9	External Interrupt 8	Yes	Yes
10	External interrupt 9	Yes	Yes
11	Watchdog Timer	Yes	Yes
12	16-Bit General-Purpose Timer 0 (GPT0)	Yes	No
13	16-Bit General-Purpose Timer 1 (GPT1)	Yes	No
14	16-Bit General-Purpose Timer 2 (GPT2)	Yes	No
15	32-Bit General-Purpose Timer 0 (GPT3)	Yes	No
16	32-Bit General-Purpose Timer 1 (GPT4)	Yes	No
17	MDIO	Yes	No
18	Flash controller	Yes	No

SYSTEM EXCEPTIONS AND PERIPHERAL INTERRUPTS

Table 11. Interrupt Vector Table (Continued)

Interrupt Number	Vector	Wake Up Processor from Mode 1	Wake Up Processor from Mode 2 or Mode 3
19	UART Channel 0 (UART0)	Yes	No
20	UART Channel 1 (UART1)	Yes	No
21	SPI Channel 0 (SPI0)	Yes	No
22	SPI Channel 1 (SPI1)	Yes	No
23	SPI Channel 2 (SPI2)	Yes	No
24	I ² C Channel 0 (I2C0) slave	Yes	No
25	I2C0 master	Yes	No
26	I ² C Channel 1 (I2C1) slave	Yes	No
27	I2C1 master	Yes	No
28	I ² C Channel 2 (I2C2) slave	Yes	No
29	I2C2 master	Yes	No
30	PLA Channel 0 (PLA0)	Yes	No
31	PLA Channel 1 (PLA1)	Yes	No
32	PLA Channel 2 (PLA2)	Yes	No
33	PLA Channel 3 (PLA3)	Yes	No
34	PWM trip	Yes	No
35	PWM Pair 0 (IRQPWM0)	Yes	No
36	PWM Pair 1 (IRQPWM1)	Yes	No
37	PWM Pair 2 (IRQPWM2)	Yes	No
37	PWM Pair 3 (IRQPWM3)	Yes	No
39	SRAM error	Yes	No
40	DMA error	Yes	No
41	DMA Channel 0 (SPI0 transmit) done	Yes	No
42	DMA Channel 1 (SPI0 receive) done	Yes	No
43	DMA Channel 2 (SPI1 transmit) done	Yes	No
44	DMA Channel 3 (SPI1 receive) done	Yes	No
45	DMA Channel 4 (SPI2 transmit) done	Yes	No
46	DMA Channel 5 (SPI2 receive) done	Yes	No
47	DMA Channel 6 (UART0 transmit) done	Yes	No
48	DMA Channel 7 (UART0 receive) done	Yes	No
49	DMA Channel 8 (UART1 transmit) done	Yes	No
50	DMA Channel 9 (UART1 receive) done	Yes	No
51	DMA Channel 10 (I2C0 slave transmit) done	Yes	No
52	DMA Channel 11 (I2C0 slave receive) done	Yes	No
53	DMA Channel 12 (I2C0 master) done	Yes	No
54	DMA Channel 13 (I2C1 Slave transmit) done	Yes	No
55	DMA Channel 14 (I2C1 slave receive) done	Yes	No
56	DMA Channel 15 (I2C1 master) done	Yes	No
57	DMA Channel 16 (I2C2 slave transmit) done	Yes	No
58	DMA Channel 17 (I2C2 slave receive) done	Yes	No
59	DMA Channel 18 (I2C2 master) done	Yes	No
60	DMA Channel 19 (MDIO transmit) done	Yes	No
61	DMA Channel 20 (MDIO receive) done	Yes	No
62	DMA Channel 21 (flash) done	Yes	No
63	DMA Channel 22 (ADC) done	Yes	No
64	PLL	Yes	No
65	High frequency oscillator	Yes	No
66	ADC	Yes	No

SYSTEM EXCEPTIONS AND PERIPHERAL INTERRUPTS

Table 11. Interrupt Vector Table (Continued)

Interrupt Number	Vector	Wake Up Processor from Mode 1	Wake Up Processor from Mode 2 or Mode 3
67	Sequencer	Yes	No
68	Comparator 0	Yes	No
69	Comparator 1	Yes	No
70	Comparator 2	Yes	No
71	Comparator 3	Yes	No
72	VDAC	Yes	No
73	Reserved	Not applicable	Not applicable
74	Reserved	Not applicable	Not applicable
75	Reserved	Not applicable	Not applicable
76	Reserved	Not applicable	Not applicable
77	Reserved	Not applicable	Not applicable
78	Reserved	Not applicable	Not applicable
79	Reserved	Not applicable	Not applicable
80	Reserved	Not applicable	Not applicable
81	Reserved	Not applicable	Not applicable
82	Reserved	Not applicable	Not applicable
83	Reserved	Not applicable	Not applicable
84	Reserved	Not applicable	Not applicable
85	Reserved	Not applicable	Not applicable
86	Reserved	Not applicable	Not applicable
87	GPIO Interrupt A	Not applicable	Not applicable
88	GPIO Interrupt B	Not applicable	Not applicable

Internal to the Arm Cortex-M33 processor, the highest user-programmable priority (0) is treated as fourth priority, which is after a reset, an NMI, and a hard fault. The ADuCM410 and ADuCM420 implement three priority bits, which means that eight priority levels are available as programmable priorities. Note that 0 is the default priority for all the programmable priorities. If the same priority level is assigned to two or more interrupts, their hardware priority (a lower interrupt number) determines the order in which the processor activates them. For example, if both SPI0 and SPI1 interrupts occur simultaneously, SPI0 takes priority because its interrupt number is lower.

To enable an interrupt for any peripheral listed from Interrupt 0 to Interrupt 31 in Table 11, set the appropriate bit in the ISER0 register. ISER0 is a 32-bit register, and each bit corresponds to the first 32 entries in Table 11.

For example, to enable the interrupt source for External Interrupt 4 in the NVIC, set ISER0, Bit 5 = 1. Similarly, to disable External Interrupt 4, set ICER0, Bit 5 = 1.

To enable an interrupt for any peripheral listed from Interrupt 32 to Interrupt 63 in Table 11, set the appropriate bit in the ISER1 register. ISER1 is a 32-bit register, and Bit 0 to Bit 31 in ISER1 correspond to Interrupt 32 to Interrupt 63 in Table 11.

For example, to enable the PWM Pair 0 interrupt source in the NVIC, set ISER1, Bit 3 = 1. Similarly, to disable the PWM Pair 0 interrupt, set ICER1, Bit 3 = 1.

Similarly, ISER2 and ICER2 enable and clear the interrupt sources in Interrupt 64 to Interrupt 88 in Table 11.

Alternatively, the Cortex microcontroller software interface standard (CMSIS) provides several useful NVIC functions in the `core_cm33.h` file. The `NVIC_EnableIRQ(PWM0_IRQn)` function enables the PWM Pair 0 interrupt. The interrupt can be disabled by calling the `NVIC_DisableIRQ(PWM0_IRQn)` function.

To set the priority of a peripheral interrupt, the IPRx bits can be set appropriately or, alternatively, the `NVIC_SetPriority()` function can be called. For example, `NVIC_SetPriority(GPT0_IRQn, 2)` configures the General-Purpose Timer 0 interrupt with a priority level of 2.

Table 12 lists the registers to enable and disable relevant interrupts and set the priority levels. The registers in Table 12 are defined in the CMSIS `core_cm33.h` file, which is shipped with tools from third party vendors.

SYSTEM EXCEPTIONS AND PERIPHERAL INTERRUPTS

Table 12. NVIC Registers

Address	Analog Devices Header File Name	Description	Access
0xE000E004	ICTR	Shows the number of interrupt lines that the NVIC supports.	R
0xE000E010	STCSR	SYSTICK control and status register.	RW
0xE000E014	STRVR	SYSTICK reload value register.	RW
0xE000E018	STCVR	SYSTICK current value register.	RW
0xE000E01C	STCR	SYSTICK calibration value register.	R
0xE000E100	ISER0	Set the appropriate bit, IRQ0 to IRQ31, to enable. Each bit corresponds to Interrupt 0 to Interrupt 31 in Table 11 .	RW
0xE000E104	ISER1	Set the appropriate bit, IRQ32 to IRQ63, to enable. Each bit corresponds to Interrupt 32 to Interrupt 63 in Table 11 .	RW
0xE000E108	ISER2	Set the appropriate bit, IRQ64 to IRQ88, to enable. Each bit corresponds to Interrupt 64 to Interrupt 88 in Table 11 .	RW
0xE000E180	ICER0	Clear IRQ0 to IRQ31 by setting the appropriate bit. Each bit corresponds to Interrupt 0 to Interrupt 31 in Table 11 .	RW
0xE000E184	ICER1	Clear IRQ32 to IRQ63 by setting the appropriate bit. Each bit corresponds to Interrupt 32 to Interrupt 63 in Table 11 .	RW
0xE000E188	ICER2	Clear IRQ64 to IRQ88 by setting the appropriate bit. Each bit corresponds to Interrupt 64 to Interrupt 88 in Table 11 .	RW
0xE000E200	ISPR0	Set the appropriate bit, IRQ0 to IRQ31, to force the interrupt source to its pending state. Each bit corresponds to Interrupt 0 to Interrupt 31 in Table 11 .	RW
0xE000E204	ISPR1	Set the appropriate bit, IRQ32 to IRQ63, to force the interrupt source to its pending state. Each bit corresponds to Interrupt 32 to Interrupt 63 in Table 11 .	RW
0xE000E208	ISPR2	Set the appropriate bit, IRQ64 to IRQ88, to force the interrupt source to its pending state. Each bit corresponds to Interrupt 64 to Interrupt 88 in Table 11 .	RW
0xE000E280	ICPR0	Clear the appropriate bit, IRQ0 to IRQ31, to remove the interrupt source from its pending state. Each bit corresponds to Interrupt 32 to Interrupt 38 in Table 11 .	RW
0xE000E284	ICPR1	Clear the appropriate bit, IRQ32 to IRQ63, to remove the interrupt source from its pending state. Each bit corresponds to Interrupt 32 to Interrupt 63 in Table 11 .	RW
0xE000E288	ICPR2	Clear the appropriate bit, IRQ64 to IRQ88, to remove the interrupt source from its pending state. Each bit corresponds to Interrupt 64 to Interrupt 88 in Table 11 .	RW
0xE000E300	IABR0	IRQ0 to IRQ31 active bits.	RW
0xE000E304	IABR1	IRQ32 to IRQ63 active bits.	RW
0xE000E308	IABR2	IRQ64 to IRQ80 active bits.	RW
0xE000E400	IPR0	IRQ0 to IRQ3 priority.	RW
0xE000E404	IPR1	IRQ4 to IRQ7 priority.	RW
0xE000E408	IPR2	IRQ8 to IRQ11 priority.	RW
0xE000E40C	IPR3	IRQ12 to IRQ15 priority.	RW
0xE000E410	IPR4	IRQ16 to IRQ19 priority.	RW
0xE000E414	IPR5	IRQ20 to IRQ23 priority.	RW
0xE000E418	IPR6	IRQ24 to IRQ27 priority.	RW
0xE000E41C	IPR7	IRQ28 to IRQ31 priority.	RW
0xE000E420	IPR8	IRQ32 to IRQ35 priority.	RW
0xE000E424	IPR9	IRQ36 to IRQ39 priority.	RW
0xE000E428	IPR10	IRQ40 to IRQ43 priority.	RW
0xE000E42C	IPR11	IRQ44 to IRQ47 priority.	RW
0xE000E430	IPR12	IRQ48 to IRQ51 priority.	RW
0xE000E434	IPR13	IRQ52 to IRQ55 priority.	RW
0xE000E438	IPR14	IRQ56 to IRQ59 priority.	RW
0xE000E43C	IPR15	IRQ60 to IRQ63 priority.	RW
0xE000E440	IPR16	IRQ64 to IRQ67 priority.	RW
0xE000E444	IPR17	IRQ68 to IRQ71 priority.	RW
0xE000E448	IPR18	IRQ72 to IRQ75 priority.	RW
0xE000E44C	IPR19	IRQ76 to IRQ79 priority.	RW
0xE000E450	IPR20	IRQ80 to IRQ83 priority.	RW
0xE000E454	IPR21	IRQ84 to IRQ87 priority.	RW
0xE000E458	IPR22	IRQ88 priority.	RW

SYSTEM EXCEPTIONS AND PERIPHERAL INTERRUPTS

Table 12. NVIC Registers (Continued)

Address	Analog Devices Header File Name	Description	Access
0xE00ED00	CPUID	Central processing unit ID (CPUID) base register.	R
0xE00ED04	ICSR	Interrupt control and status register.	RW
0xE00ED08	VTOR	Vector table offset register.	RW
0xE00ED0C	AIRCR	Application interrupt/reset control register.	RW
0xE00ED10	SCR	System control register.	RW
0xE00ED14	CCR	Configuration control register.	RW
0xE00ED18	SHPR1	System Handlers Register 1.	RW
0xE00ED1C	SHPR2	System Handlers Register 2.	RW
0xE00ED20	SHPR3	System Handlers Register 3.	RW
0xE00ED24	SHCRS	System handler control and state.	RW
0xE00ED28	CFSR	Configurable fault status.	RW
0xE00ED2C	HFSR	Hard fault status.	RW
0xE00ED34	MMAR	Memory manage fault address register.	RW
0xE00ED38	BFAR	Bus fault address.	RW
0xE00EF00	STIR	Software trigger interrupt register.	W

EXTERNAL INTERRUPT CONFIGURATION

The ADuCM410 and ADuCM420 implement 10 external interrupts that can be separately configured to detect any combination of the following type of events:

- ▶ Rising edge: the logic detects a transition from low to high and generates a pulse. Only one pulse is sent to the Cortex-M33 per rising edge.
- ▶ Falling edge: the logic detects a transition from high to low and generates a pulse. Only one pulse is sent to the Cortex-M33 per falling edge.
- ▶ Rising edge or falling edge: the logic detects a transition from low to high or high to low and generates a pulse. Only one pulse is sent to the Cortex-M33 per edge.
- ▶ High level: the logic detects a high level. The appropriate interrupt is asserted and sent to the Cortex-M33. The interrupt line is held asserted until the external source deasserts. The high level must be maintained for one core clock (HCLK) cycle minimum to be detected.
- ▶ Low level: the logic detects a low level. The appropriate interrupt is asserted and sent to the Cortex-M33. The interrupt line is held asserted until the external source deasserts. The low level must be maintained for one core clock (HCLK) cycle minimum to be detected.

The external interrupt detection unit block is in the always on section and allows external interrupts to wake up the device when in hibernate mode.

Ensure that the associated GPxIE register bit is enabled for the required external interrupt input. The GPxIE register enables the input path circuit for the external interrupt.

External Interrupt Request (IRQ) Mode

Five external interrupt modes can be enabled or disabled. These modes are set up via the EI0CFG, EI1CFG, and EI2CFG registers.

Table 13. External Interrupt Mode Selection for IRQxMDE (x = 0 to 9)

Settings	External interrupt Mode
0x0	Rising edge
0x1	Falling edge
0x2	Rising or falling edge
0x3	High level
0x4	Low level
0x5	Falling edge (same as 0x1)
0x6	Rising or falling edge (same as 0x2)
0x7	High level (same as 0x3)

SYSTEM EXCEPTIONS AND PERIPHERAL INTERRUPTS

REGISTER SUMMARY: EXTERNAL INTERRUPTS

Table 14. External Interrupts Register Summary

Address	Name	Description	Reset	Access
0x40005020	EIOCFG	External Interrupt Configuration 0	0x0000	R/W
0x40005024	EI1CFG	External Interrupt Configuration 1	0x0000	R/W
0x40005028	EI2CFG	External Interrupt Configuration 2	0x0000	R/W
0x40005030	EICLR	External interrupt clear	0x0000	R/W

REGISTER DETAILS: EXTERNAL INTERRUPTS

External Interrupt Configuration 0 Register

Address: 0x40005020, Reset: 0x0000, Name: EIOCFG

Table 15. Bit Descriptions for EIOCFG

Bits	Bit Name	Settings	Description	Reset	Access
15	IRQ3EN		External Interrupt 3 Enable Bit	0x0	R/W
		0x0	External Interrupt 3 Disabled.		
		0x1	External Interrupt 3 Enabled.		
[14:12]	IRQ3MDE		External Interrupt 3 Mode Registers. See Table 13 for more details.	0x0	R/W
11	IRQ2EN		External Interrupt 2 Enable Bit	0x0	R/W
		0x0	External Interrupt 2 Disabled.		
		0x1	External Interrupt 2 Enabled.		
[10:8]	IRQ2MDE		External Interrupt 2 Mode Registers. See Table 13 for more details.	0x0	R/W
7	IRQ1EN		External Interrupt 1 Enable Bit	0x0	R/W
		0x0	External Interrupt 1 Disabled.		
		0x1	External Interrupt 1 Enabled.		
[6:4]	IRQ1MDE		External Interrupt 1 Mode Registers. See Table 13 for more details.	0x0	R/W
3	IRQ0EN		External Interrupt 0 Enable Bit	0x0	R/W
		0x0	External Interrupt 0 Disabled.		
		0x1	External Interrupt 0 Enabled.		
[2:0]	IRQ0MDE		External Interrupt 0 Mode Registers. See Table 13 for more details.	0x0	R/W

External Interrupt Configuration 1 Register

Address: 0x40005024, Reset: 0x0000, Name: EI1CFG

Table 16. Bit Descriptions for EI1CFG

Bits	Bit Name	Settings	Description	Reset	Access
15	IRQ7EN		External Interrupt 7 Enable Bit	0x0	R/W
		0x0	External Interrupt 7 Disabled.		
		0x1	External Interrupt 7 Enabled.		
[14:12]	IRQ7MDE		External Interrupt 7 Mode Registers. See Table 13 for more details.	0x0	R/W
11	IRQ6EN		External Interrupt 6 Enable Bit	0x0	R/W
		0x0	External Interrupt 6 Disabled.		
		0x1	External Interrupt 6 Enabled.		
[10:8]	IRQ6MDE		External Interrupt 6 Mode Registers. See Table 13 for more details.	0x0	R/W
7	IRQ5EN		External Interrupt 5 Enable Bit	0x0	R/W
		0x0	External Interrupt 5 Disabled.		
		0x1	External Interrupt 5 Enabled.		
[6:4]	IRQ5MDE		External Interrupt 5 Mode Registers. See Table 13 for more details.	0x0	R/W
3	IRQ4EN		External Interrupt 4 Enable Bit	0x0	R/W
		0x0	External Interrupt 4 Disabled.		

SYSTEM EXCEPTIONS AND PERIPHERAL INTERRUPTS

Table 16. Bit Descriptions for EI1CFG (Continued)

Bits	Bit Name	Settings	Description	Reset	Access
		0x1	External Interrupt 4 Enabled.		
[2:0]	IRQ4MDE		External Interrupt 4 Mode Registers. See Table 13 for more details.	0x0	R/W

External Interrupt Configuration 2 Register

Address: 0x40005028, Reset: 0x0000, Name: EI2CFG

Table 17. Bit Descriptions for EI2CFG

Bits	Bit Name	Settings	Description	Reset	Access
[15:8]	RESERVED		Reserved.	0x0	R
7	IRQ9EN		External Interrupt 9 Enable Bit 0 External Interrupt 9 Disabled. 1 External Interrupt 9 Enabled.	0x0	R/W
[6:4]	IRQ9MDE		External Interrupt 9 Mode Registers. See Table 13 for more details.	0x0	R/W
3	IRQ8EN		External Interrupt 8 Enable Bit 0 External Interrupt 8 Disabled. 1 External Interrupt 8 Enabled.	0x0	R/W
[2:0]	IRQ8MDE		External Interrupt 8 Mode Registers. See Table 13 for more details.	0x0	R/W

External Interrupt Clear Register

Address: 0x40005030, Reset: 0x0000, Name: EICLR

Table 18. Bit Descriptions for EICLR

Bits	Bit Name	Settings	Description	Reset	Access
[15:10]	RESERVED		Reserved.	0x0	R
9	IRQ9		External Interrupt 9. Set to 1 to clear an internal interrupt flag. Cleared automatically by hardware.	0x0	R/W
8	IRQ8		External Interrupt 8. Set to 1 to clear an internal interrupt flag. Cleared automatically by hardware.	0x0	R/W
7	IRQ7		External Interrupt 7. Set to 1 to clear an internal interrupt flag. Cleared automatically by hardware.	0x0	R/W
6	IRQ6		External Interrupt 6. Set to 1 to clear an internal interrupt flag. Cleared automatically by hardware.	0x0	R/W
5	IRQ5		External Interrupt 5. Set to 1 to clear an internal interrupt flag. Cleared automatically by hardware.	0x0	R/W
4	IRQ4		External Interrupt 4. Set to 1 to clear an internal interrupt flag. Cleared automatically by hardware.	0x0	R/W
3	IRQ3		External Interrupt 3. Set to 1 to clear an internal interrupt flag. Cleared automatically by hardware.	0x0	R/W
2	IRQ2		External Interrupt 2. Set to 1 to clear an internal interrupt flag. Cleared automatically by hardware.	0x0	R/W
1	IRQ1		External Interrupt 1. Set to 1 to clear an internal interrupt flag. Cleared automatically by hardware.	0x0	R/W
0	IRQ0		External Interrupt 0. Set to 1 to clear an internal interrupt flag. Cleared automatically by hardware.	0x0	R/W

RESET

RESET FEATURES

There are four kinds of resets: external reset, power-on reset (POR), watchdog timeout, and software system reset.

RESET OPERATION

The software system reset is provided as part of the Cortex-M33 processor. To generate a software system reset, the application interrupt or reset control register must be written to 0x05FA0004. This register is part of the NVIC register and is located at Address 0xE00ED0C.

Analog peripherals have the option of maintaining their state after a software or watchdog reset. This function is enabled by default, but can be disabled through RSTCFG, Bit 3. Note that while debugging, the software tools generally only issue a software reset. Therefore, an external reset is needed to return registers to their default values.

The GPIO pins and PLA also have the option of maintaining their state after a software or watchdog reset. By default, this function is enabled. Writing a value of 0x1 to RSTCFG configures the GPIO pins and PLA to reset after a software or watchdog reset. Before writing to this register, 0x2009 must be written to RSTKEY followed by 0x0426. After the two keys are written to RSTKEY, RSTCFG must be immediately written.

The RSTSTA register stores the cause for the reset until the bit is cleared by writing to the RSTSTA register. RSTSTA can be used during a reset exception service routine to identify the source of the reset.

The watchdog timer is enabled by default after a reset. The default timeout period is approximately 32 sec.

User code must disable the watchdog timer at the start of user code when debugging or when the watchdog timer is not required, as follows:

```
pADI_WDT->T3CON = 0x00; // Disable watchdog timer
```

Table 19. Device Reset Implications

Reset	Impact					RSTSTA After Reset Event
	Reset External Pins to Default State	Execute Kernel	Reset All MMRs Except RSTSTA	Reset All Peripherals	Valid SRAM	
Software Reset	Yes/No ¹	Yes	Yes/No ¹	Yes/No ¹	Yes	RSTSTA, Bit 3 = 1
Watchdog Timeout	Yes/No ¹	Yes	Yes/No ¹	Yes/No ¹	Yes	RSTSTA, Bit 2 = 1
External Reset Pin	Yes	Yes	Yes	Yes	Yes	RSTSTA, Bit 1 = 1
POR	Yes	Yes	Yes	Yes	No	RSTSTA, Bit 0 = 1

¹ GPIOs, PLA, and analog peripherals have the option of retaining their output state during a watchdog or software reset.

REGISTER SUMMARY: RESET

Table 20. Reset Register Summary

Address	Name	Description	Reset	Access
0x40005008	RSTCFG	Reset configuration	0x000F	RW
0x4000500C	RSTKEY	Key protection for RSTCFG	0x0000	RW
0x40005040	RSTSTA	Reset status	0x0000	RW

RESET**REGISTER DETAILS: RESET**
Reset Configuration Register

Address: 0x40005008, Reset: 0x0000, Name: RSTCFG

Table 21. Bit Descriptions for RSTCFG

Bits	Bit Name	Settings	Description	Reset	Access
[15:4]	RESERVED		Reserved.	0x0	R
3	ANA_RETAIN		Analog Blocks Retain Status After Watchdog or Software Reset 0 Analog Blocks Retain Status After Watchdog or Software Reset. 1 Analog Blocks Do Not Retain Status After Watchdog or Software Reset.	0x1	R/W
[2:1]	RESERVED		Reserved.	0x1	R/W
0	GPIO_PLA_RETAIN		GPIO/PLA Retain Their Status After Watchdog Timer Reset and Software Reset. P2.1 and 2.3 are not affected by this register. They do not retain their state. 0 GPIO/PLA Retain Status After Watchdog or Software Reset. 1 GPIO/PLA Does not Retain Status After Watchdog or Software Reset.	0x1	R/W

Key Protection for RSTCFG Register

Address: 0x4000500C, Reset: 0x0000, Name: RSTKEY

Table 22. Bit Descriptions for RSTKEY

Bit(s)	Bit Name	Description	Reset	Access
[15:0]	RSTKEY	Reset configuration key register. The RSTCFG register is key protected. Two writes to the key are necessary to change the value in the RSTCFG register: first 0x2009, then 0x0426. The RSTCFG register must then be written to. A write to any other register on the APB before writing to RSTCFG returns the protection to the lock state.	0x0	RW

Reset Status Register

Address: 0x40005040, Reset: 0x0000, Name: RSTSTA

Table 23. Bit Descriptions for RSTSTA

Bit(s)	Bit Name	Description	Reset	Access
[15:4]	RESERVED	Reserved.	0x0	R
3	SWRST	Software reset. Set automatically to 1 when the Cortex-M33 system reset is generated. Cleared by writing 1 to this bit.	0x0	RW1C
2	WDRST	Watchdog timeout. Set automatically to 1 when a watchdog timeout occurs. Cleared by writing 1 to this bit.	0x0	RW1C
1	EXTRST	External reset. Set automatically to 1 when an external reset occurs. Cleared by writing 1 to this bit.	0x0	RW1C
0	POR	Power-on reset. Set automatically when a power-on reset occurs. Cleared by writing one to this bit.	0x0	RW1C

ANALOG PIN FUNCTIONALITY

The ADuCM410 and ADuCM420 combine multiple functions on the same analog input/output pins.

This section details the alternate functions of each analog I/O pin and describes the limitations.

Table 24.

Pin Mnemonic	Comments
AIN15/COM3N/BUF0_VREF AIN14/COM3P/BUF0_VREF	Three analog functions can be used at the same time: the buffered reference outputs can be measured via AIN15 or AIN14 while connected to the Comparator 3 amplifier. Higher input current flows in these analog pins if the comparator is enabled.
AIN2/PADC0P AIN3/PADC1P AIN5/PADC2P AIN6/PADC3P AIN8/COP0P AIN10/COM1P AIN12/COM2P AIN13/COM2N	Both functions can be used at the same time for all these pins. Only one of the AINx or PADCxP inputs can be sampled by the ADC at any given time. Higher input current flows in these analog pins if the comparator is enabled.
AIN9/COM0N/PGA2OUT AIN11/COM1N/PGA0OUT	The comparator function can be enabled at the same time as either the AINx or PGAxOUT function. Higher input current flows in these analog pins if the comparator is enabled.
AIN4/PADC01N/VDAC0 AIN7/PADC23N/VDAC2	Only AIN4 and AIN7 can be used with the VDAC or PGA function. The VDAC and PGA functions cannot be used at the same time.
VDAC8/P5.0 VDAC9/P5.1 VDAC10/P5.2 VDAC11/P5.3	Use only one of these two options on each pin at any given time.
VDAC3/P4.0/PLAI11 VDAC6/P4.1/PLAO28 VDAC5/P4.4 VDAC7/P4.2	Do not use the digital GPIO function and DAC output function at the same time.

ADC CIRCUIT

ADC CIRCUIT FEATURES

The ADuCM410 and ADuCM420 incorporate a fast, multichannel, 16-bit ADC and 12-bit ADC, respectively.

A flexible input multiplexer supports 16 external inputs and several internal channels. The internal channels include the following:

- ▶ A temperature sensor channel.
- ▶ An internal 2.5 V reference.
- ▶ An external reference.
- ▶ $IOVDD0 \div 2$ and $IOVDD1$ supply voltages.
- ▶ $AVDD \div 2$ and $DVDD \div 2$ supply voltages.

An input precharge buffer can be selected for any channel to allow very low input current and input leakage specifications on these input channels.

A high precision, low drift internal 2.5 V reference source is provided. An external reference can also be connected to the ADCREFP and ADCREFN pins.

The programmable ADC update rate is from 100 kSPS to 2 MSPS.

Each channel has its own distinct data register for its conversion result. For example, when AIN0 is selected, the result appears in ADCDAT0. If AIN7 is selected, the result appears in ADCDAT7. For a differential measurement, the result always appears in the data register of the positive channel.

ADC CIRCUIT BLOCK DIAGRAM

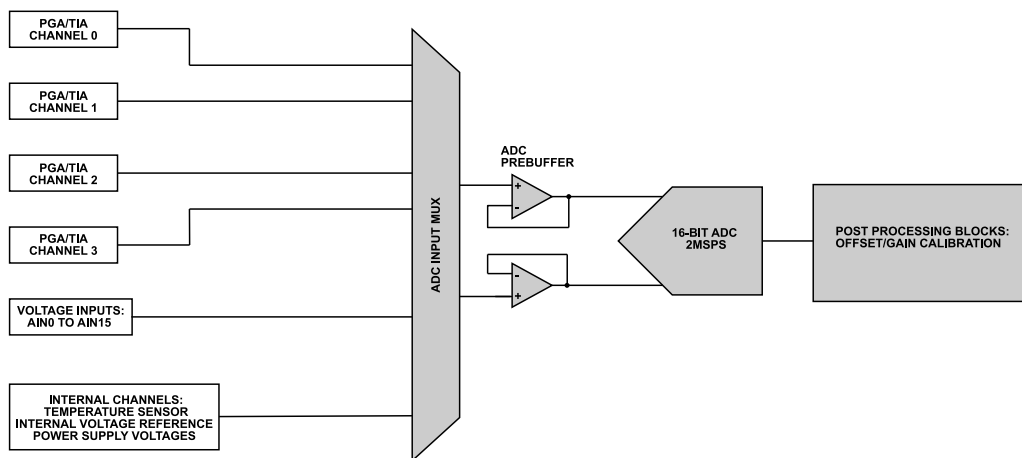

Figure 2. ADC Circuit Block Diagram

ADC CIRCUIT OVERVIEW

The ADuCM410 incorporates a fast, multichannel, 16-bit ADC, and the ADuCM420 has a 12-bit ADC that can provide a throughput of up to 2 MSPS. This ADC block provides the user with a multichannel multiplexer, a precharge buffer for high impedance input channels, an on-chip reference, and a successive approximation register (SAR) ADC.

A high precision, low drift, factory calibrated, 2.5 V reference is provided on chip. An external reference can also be connected to the ADCREFP and ADCREFN pins.

ADC CIRCUIT OPERATION

The input mux selects one of the external AIN0 to AIN15 channels or internal channels (such as PGAs, TIAs, or temperature sensor).

ADC CIRCUIT

ADC CHANNEL SEQUENCER

An ADC sequencer is provided to reduce the processor overhead of sampling and reading individual channels. The ADC sequencer allows the user to select the ADC input channels that the ADC samples, via the ADCSEQCH, ADCSEQCHMUX0, and ADCSEQCHMUX1 registers, and provides an interrupt source that is asserted at the end of the sequence. The sequencer can only work in continuous mode. The sequencer can also be programmed to restart from the first configured channel, but the current ADC conversion must first be executed completely.

Sequencer Mode: Single Sequence

When ADCSEQC, Bits[7:0] is equal to 255, the sequencer runs in a single sequence. The sequencer automatically causes a halt after one sequence.

Sequencer Mode: Repeat Sequence

When ADCSEQC, Bits[7:0] is not equal to 255, the sequencer runs in a repeat sequence. After one sequence ends and waits a period of ADCSEQC, Bits[7:0] × ADCCNVC or ADCCNVSLOW cycles, the sequencer runs again. The repeat sequence can be stopped by configuring ADCSEQC, Bits[7:0] to 255. The sequencer cannot be turned off immediately by configuring ADCSEQC, Bits[7:0] to 255 until all the current channels in the sequence loop finish.

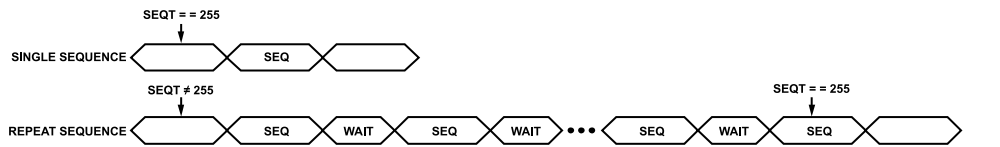

Figure 3. Single and Repeat Sequences

AINx and Negative (N)/Positive (P) Mux Channel Selection

Channel P or Channel N selection is used for mux selection in sequencer mode, which can be configured through ADCSEQCHMUX0, Bits[29:0] and ADCSEQCHMUX1, Bits[9:0], respectively.

Table 25. Channel N or Channel P Selection

Channel	Settings	Selection
Channel N	0x0	REFN
	0x1	REFP
	0x2	AIN1
	0x3	AIN3
	0x4	AIN5
	0x5	AIN7
	0x6	AIN9
	0x7	AIN11
	0x8	AIN13
	0x9	AIN15
	0xA to 0xF	All other combinations are reserved
Channel P	0x0	REFN
	0x1	REFP

ADC CIRCUIT

ADC TRANSFER FUNCTION

Single-Ended Mode

In single-ended mode, the input range is 0 V to VREF. The output coding is straight binary with

$$1 \text{ LSB} = FS/65,536 \quad (1)$$

where FS is full scale.

or

$$VREF/65,536 = 2.50 \text{ V}/65,536 = 38.14 \text{ } \mu\text{V} \quad (2)$$

In differential mode, the equation is

$$(2 \times VREF)/65,536 = (2 \times 2.50 \text{ V})/65,536 = 76.28 \text{ } \mu\text{V} \quad (3)$$

The data values in ADCDATx are aligned such that the most significant bit (MSB) is in ADCDATx, Bit 19 and, therefore, the least significant bit (LSB) is in ADCDATx, Bit 4. The ideal code transitions occur midway between successive integer LSB values (that is, $\frac{1}{2}$ LSB, $\frac{3}{2}$ LSB, $\frac{5}{2}$ LSB, ..., $FS - \frac{3}{2}$ LSB). The ideal input/output transfer characteristic is shown in [Figure 4](#).

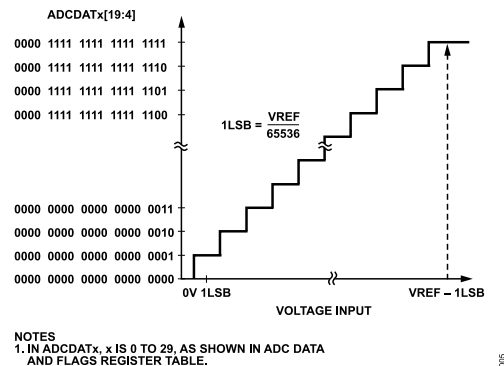

Figure 4. ADC Transfer Function: Single-Ended Mode

TIA Channel With AC Mode Enabled

The ADuCM410 supports both sinking and sourcing current measurements via the TIA.

To enable this,

- ▶ Set PGAxCON, Bit 1 = 1 to enable TIA mode.
- ▶ Set PGAxCON, Bit 2 = 1 to enable AC mode.
- ▶ Clear PGAxCON, Bit 3 = 0 to bypass the feedback on the amplifier.
- ▶ Clear PGAxCON, Bit 4 = 0 to support the full current sink range.

With this configuration, the ADC output is signed with Bit 19 as the sign bit.

When sinking current, the ADC codes in Bits[19:4] of ADCDAT16, ADCDAT17, ADCDAT18, and ADCDAT19 range from 0xFFFF to 0x8000.

When sourcing current, the ADC codes in Bits[19:4] of ADCDAT16, ADCDAT17, ADCDAT18, and ADCDAT19 range from 0x0000 to 0x7FFF.

When sinking current, set the common-mode voltage of the TIA as high as possible to maximize the output range. A value of 2.5 V on the VDAC allows a TIA output range of 2.5 V (zero-scale input current) down to 0.25 V (close to full-scale input current range). The 0.25 V value is the minimum output voltage supported by the TIA (see the ADuCM410 data sheet for more details).

When sourcing current, set the common-mode voltage of the TIA as low as possible to maximize the output range. A value of 0.25 V on the associated VDAC allows a TIA output range of 0.25 V (zero-scale input current) up to 2.5 V (close to full-scale input current range). The 2.5 V value is the maximum output voltage supported by the TIA (see the ADuCM410 data sheet for more details).

ADC CIRCUIT

ADC OVERSAMPLING AND OUTPUT DATA RATE

ADCCNVC configures the ADC conversion rate for the AIN0 to AIN15 ADC channels.

ADCCNVCSLOW configures the ADC conversion for the following ADC channels:

- ▶ Temperature sensor and PGA channels. These channels have an optional chop feature, meaning two samples are taken per conversion with chop enabled.
- ▶ Internal supply channels: $AVDD \div 2$, $IOVDD0 \div 2$, $DVDD \div 2$, and $IOVDD1$.

ADCCON, Bits[12:10] configure the ADC oversampling feature. The oversampling feature results in the ADC output rate selected by the user in ADCCNVC and ADCCNVCSLOW, but, internally, the ADC oversamples by the value selected via ADCCON, Bits[12:10].

For example, if ADCCON, Bits[12:10] = 0b010 for an oversampling rate of 4× and ADCCNVC = 0x100, the ADC output rate seen by the user is still 125 kSPS, but the ADC takes four samples at 600 kSPS and averages these results to still achieve the 125 kSPS throughput rate.

The user must ensure that the ADC conversion rate never exceeds 2 MSPS for the AIN0 to AIN15 channels. Care must be taken when enabling oversampling that

$$(32 \text{ MHz}/ADCCNVC) \times \text{Oversampling Rate} \leq 2 \text{ MSPS} \quad (4)$$

All ADC input channels support oversampling rates up to 16.

However, only the external AIN0 to AIN15 channels support the oversampling rate of 32. The internal channels and the PGA and TIA channels do not support the oversampling value of 32.

Oversampling and the TIA Channels

For the TIA channels, there are limitations to the maximum ADC update rates allowed. Therefore, the user must be careful with the value loaded into the ADCCNVCSLOW register and the selected oversampling rate.

When using TIA mode, it is recommended to enable chop mode of the TIA amplifier via the PGAxCHPCON registers.

Table 26. TIA Channels Oversampling Constraints

TIA Gain	Maximum Allowed Effective ADC Sampling Rate ¹ (kSPS)	Comments
250 Ω, 750 Ω, 2 kΩ	800	If OSR = 8, maximum ADCCNVCSLOW value allowed is 100 kSPS. ADC interrupt occurs at 100 kSPS, but, internally, ADC is taking eight samples at 800 kSPS. If chop is enabled, ADC interrupt occurs at 50 kSPS rate.
5 kΩ, 10 kΩ, 20 kΩ	200	If OSR = 8, maximum ADCCNVCSLOW value allowed is 25 kSPS. ADC interrupt occurs at 25 kSPS, but, internally, ADC is taking eight samples at 200 kSPS. If chop is enabled, ADC interrupt occurs at 12.5 kSPS rate.
100 kΩ	100	If OSR = 4, maximum ADCCNVCSLOW value allowed is 25 kSPS. ADC interrupt occurs at 25 kSPS, but, internally, ADC is taking four samples at 100 kSPS. If chop is enabled, ADC interrupt occurs at 12.5 kSPS rate.

¹ (ADCCNVCSLOW × Oversampling Rate) × Chop Rate. If chopping is enabled, chop rate = 2. Else, chop rate = 1.

DIGITAL COMPARATORS OVERVIEW

Four independent ADC digital comparators compare the ADC result with a digital threshold. If this threshold is exceeded for the required ADC channel, an interrupt is triggered. Each digital comparator has a dedicated interrupt vector. The interrupts are described in the [System Exceptions and Peripheral Interrupts](#) section.

The interrupt can be triggered by the ADC going above or below the threshold value.

The positive input of the comparator is configured by ADCCMPx, Bits[17:2], which set the ADC result threshold value.

ADC CIRCUIT

PGA/TIA INPUT AMPLIFIER (ADUCM410 ONLY)

The ADuCM410 contains four input amplifiers that can be configured as programmable voltage gain amplifiers or as TIAs to convert current inputs to a voltage that the ADC can measure.

When using the PGA or TIA channels, it is recommended to enable chopping via the PGAxCHPCON registers. With chopping enabled, the ADC sampling time is doubled because two samples are needed per ADC result.

TIA Mode (ADuCM410 Only)

In TIA mode, the input amplifiers are configured to measure the output current from external photodiodes.

A VDAC channel is required to set the noninverting input bias voltage.

The ADC measures the differential voltage across the inverting terminal and the output voltage of the amplifier, thus measuring the voltage drop across the TIA gain resistors, R_{TIA} .

Disable all biasing amplifiers. For example, to disable the 0.2 V and 1.25 V bias voltage amplifiers, use the following code:

```
pADI_PGA->PGABIASCON = 0x3F; // Disable 1.25V and disable 0.2V bias buffers to TIA amplifier.
```

This register setting allows the selected VDAC channel to set the noninverting input voltage of the amplifier.

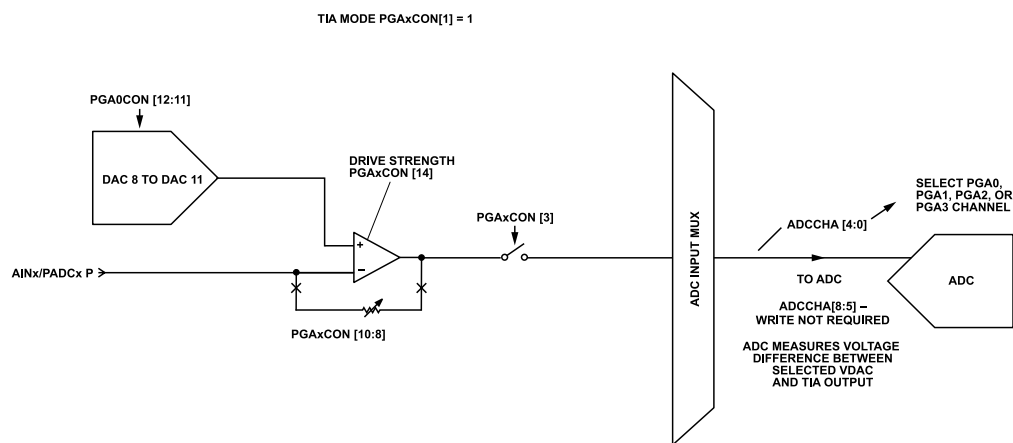

Figure 5. PGA Amplifier in TIA Mode

The following code configures the Channel 0 amplifier for TIA mode:

```
DacWr(pADI_DAC8, 0xC00); // Set VDAC8 to 1.875V
pADI_PGA->PGABIASCON = 0x3F; // Disable 1.25V and 0.2V bias buffers to TIA amplifier
pADI_PGA->PGA0CHPCON = 1; // 1 = disable chop; 0=enable chop
pADI_PGA->PGA0CON = 0x410E; // Extra drive (bit 14), Gain res=750ohms (bit 8), bypass cap
(bit 3), TIA/AC mode (bits 3 & 1). VDAC8 bias. Clear Bit 4.
pADI_ADC->ADCCHA = 0x10; // PGA0 = p input, VREFN = N input
```

The following code converts the ADC results to current in μA :

```
data = ((pADI_ADC->ADCDAT16) >> >>BITP_ADC_ADCDAT_N_DAT); // read PGA0 result and right shift
4 places.
fPGAVoltage = (data / 65536.0) * 2500;
fPGACurrent = (fPGAVoltage / uiGainAdjust) * 1000; // if RTIA = 750, then uiGainAdjust = 750.
AdcData[i] = AdcData[i] >> BITP_ADC_ADCDAT_N_DAT;
```

ADC CIRCUIT

```

iADC_DAT_BiPol = (uint32_t)AdcData[i];
if (AdcData[i] < 32768) // if Sourcing current
{
    volt = (iADC_DAT_BiPol/32768.0f*2500);
    current = -(volt*1000)/RTIA;
}
else
{
    iADC_DAT_BiPol = (65535 - iADC_DAT_BiPol) ;
    volt = iADC_DAT_BiPol/32768.0f*2500;
    current = (volt*1000)/RTIA;
}

```

PGA DC Mode (ADuCM410 Only)

PGA dc mode measures an external photodiode current. The photodiode current is converted to a voltage externally by connecting the diode to a resistor and biasing this resistor with 200 mV via internal biasing amplifiers (see the PGABIASCN register in [Table 52](#)). Each side of this external resistor is connected to the PGA amplifier, but it can also be used to amplify and measure a differential dc voltage.

When the PGA is selected as the ADC positive input, select the reference negative terminal as the ADC N channel (ADCCHA, Bits[8:5] = 0b0000).

To use PGA Channel 0, apply an external voltage across AIN2 and AIN4. Select the PGA0 channel from the ADC mux as the positive input (see [Table 31](#)).

In single-ended mode, the input range is 0 to VREF. The output coding is straight binary with

$$1 \text{ LSB} = (FS/65,536)/PGAGAIN \quad (5)$$

where:

FS is full scale.

PGAGAIN is set by PGA0CON, Bits[7:5].

To calculate a voltage from the PGA channels, assuming PGA Channel 0 is measured relative to VREFN,

$$(((ADC_DAT \times 65,536) \times VREF)/PGAGAIN) + \text{Biasing Amplifier Voltage} \quad (6)$$

For example, if VREF = 2.5 V and PGAGAIN = 4,

$$(((ADC_DAT \times 65,536) \times 2.5)/4) + 0.2 \quad (7)$$

To calculate a voltage from the PGA channels, assuming PGA Channel 0 and external voltage applied between AIN2 and AIN4,

$$(((ADC_DAT \times 65,536) \times VREF)/PGAGAIN) \quad (8)$$

For example, if VREF = 2.5 V and PGAGAIN = 4,

$$(((ADC_DAT \times 65,536) \times 2.5)/4) \quad (9)$$

ADC CIRCUIT

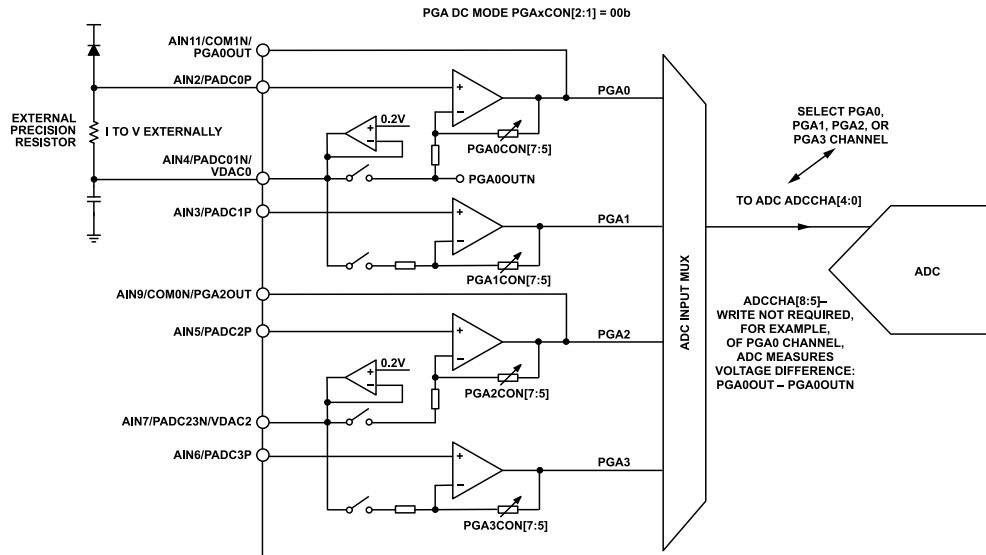

Figure 6. PGA Amplifier in DC PGA Gain Mode

PGA AC Mode (ADuCM410 Only)

In PGA ac mode, an external ac voltage signal is connected to the noninverting input of the PGA amplifier.

The following are key points on the amplifier operation in ac mode:

- ▶ All four PGA channels can be independently used to measure external ac signals.
- ▶ Select PGA0, PGA1, PGA2, or PGA3 for the ADC N terminal and P terminal mux inputs to measure each channel.
- ▶ The measurement is a differential measurement.
- ▶ Optional output low-pass filter on the PGA0 and PGA2 channels only. An external capacitor can be connected to the AINx/COMxN/PAGAxOUT pin. The connection to this capacitor can be bypassed via PGAxCON, Bit 3.
- ▶ $R_{LOWPASS}$ is typically 1 kΩ. A recommended external capacitor if using the output filter is 10 nF.
- ▶ $R_{HIGHPASS}$ is typically 265 kΩ.

The output voltage at the P terminal of the ADC input mux is

$$= V_{CM_OUT} + (Gain \text{ set by } PGAxCON, Bits[7:5] \times V_{IN})$$

where V_{CM_OUT} is the voltage seen by the N terminal of the ADC mux (the output of the common-mode voltage buffer).

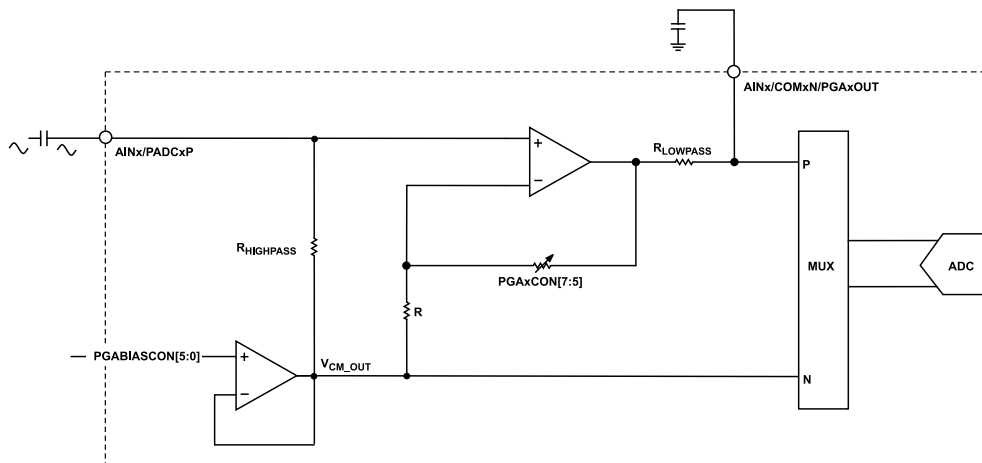

Figure 7. PGA Amplifier in AC PGA Gain Mode

ADC CIRCUIT

TEMPERATURE SENSOR CHANNEL

The temperature sensor ADC channel measures the die temperature. At least a single-point calibration is recommended.

By default, the temperature sensor channel enables chop mode, where the ADC hardware takes two samples and averages them in hardware before the result is sent to ADCDAT20. The temperature sensor channel is measured differentially. Configure ADCCHA, Bits[4:0] = 0x14. ADCCHA, Bits[8:5] are ignored.

Chopping can be enabled or disabled via the TMPSENSCHPCON register. With chopping disabled, the ADC sampling period for this channel is set by ADCCNVCSLOW. With chopping enabled, this sampling period is 2× the sampling time set by ADCCNVCSLOW.

The temperature sensor channel offset and gain calibration registers are ADCOFTEMP and ADCGNTEMP.

To calculate the die temperature in °C, use the following equation:

$$\text{Temperature} = ((\text{ADCDAT20} \gg 4) / 6.01) - 273.15 \quad (10)$$

The following is an example initialization function for the ADC temperature sensor channel:

```
void TempSensorTest ()
{
    float fTemperature = 0.00;

    pADI_TMPSENS->TMPSENSCON = BITM_VCM_MMRS_TMPSENSCON_ENTMPSENS; // Enable the temperature sensor
    AdcPinSingleExt(CHAN_TEMPSENS); // Select ADC temperature sensor channel
    NVIC_EnableIRQ(ADC_IRQn); //enable interrupt
    AdcGo(ENUM_ADC_ADCCON_CONVTYPE_CONT); //ADC continuous conversion
    while(conversionDone==0); //wait for conversion finish - set in the ADC interrupt handler
    function

    fTemperature = ((REG_ADC_TEMP_DAT20 >>4) / 6.01) - 273.15;
    PRINTF("Temp. Sensor Result, %fC", fTemperature);
}
```

OTHER INTERNAL CHANNELS

Apart from the PGA, TIA, and temperature sensor channels, the ADuCM410 and ADuCM420 ADC mux also supports measurement of the power supply rails.

For the DVDD supply rail, the ADC positive Channel 29 of ADCCHA, Bits[4:0] can be configured to measure either DVDD ÷ 2 or AGND. The selection is made via ADCCON, Bit 8.

ADC CALIBRATION

The ADuCM410 and ADuCM420 ADC is factory calibrated for voltage offset and gain. These calibration values are stored in the ADCOFGN-DIFF register (see [Table 45](#)).

This register is user accessible if further system calibration is required. This register applies to both single-ended and differential operation.

The PGA channels have additional gain calibration registers: ADCOFGNPGA0, ADCOFGNPGA1, ADCOFGNPGA2, and ADCOFGNPGA3. These registers are not factory calibrated and contain a default value. These registers allow a user to calibrate for the errors associated with PGA amplifiers when configured to either measure a voltage or a current in TIA mode. The calibration range is ~±3%. Therefore, this range is not enough to fully calibrate the absolute error of the TIA gain resistor. If calibration is required for this resistor, calibration must be completed at a system level where a known current into the TIA is used for calibration.

The ADC temperature sensor channel has its own offset and gain calibration registers, ADCOFTEMP and ADCGNTEMP. These registers contain a factory default value.

ADC CIRCUIT**ADC INTERRUPTS**

The following code shows how to set up the ADuCM410 and ADuCM420 ADC to trigger interrupts to Cortex-M33 after every conversion:

```
uint32_t sta;
uint32_t data;
sta = 0;

AdcSetup(&gAdcSetup); // Call
initialization function of ADC
AdcPinSingleExt(SING_END_CHAN_AIN1_REFN); // Single Ended measurement of AIN1 channel
NVIC_EnableIRQ(ADC_IRQn); // Enable ADC interrupt in the
nVIC
AdcGo(ENUM_ADC_ADCCON_CONVTYPE_CONT); //ADC continuous conversion

// Example interrupt Handler for the ADC:
void ADC_Int_Handler(void)
{
    sta = pADI_ADC->ADCIRQSTAT; //must read to clear status
    if(sta & BITM_ADC_ADCIRQSTAT_CNVRQSTAT) //Continuous conversion triggered interrupt
    {
        data = REG_ADC_REF_AIN1_DAT1 // read ADCDAT1 register for the ADC result
    }
}
```

Polling Status Bits for ADC Conversions

The following code shows how to poll the ADC status bits to determine if an ADC conversion has completed, if the ADC interrupts are not used in the user application:

```
uint32_t sta;
uint32_t data;

sta = 0;
AdcGo(ENUM_ADC_ADCCON_CONVTYPE_CONT); //Function call to start continuous ADC conversions
while ((sta & 0x1) == 0) // Wait for
conversion to complete
{
    sta = pADI_ADC->ADCIRQSTAT;
}
data = pADI_ADC->ADCDATx; // read the selected ADC Data
register
```

ADC CIRCUIT

ADC POWER-UP REQUIREMENTS

The digital logic associated with the ADC block requires the AVDD supply to be fully powered up latest, 25 ms after the DVDD supply.

If the AVDD supply powers up more than 25 ms after DVDD, there is a risk that the ADC block does not power up properly and results in inaccurate ADC results.

If the AVDD supply cannot be powered up within 25 ms of the DVDD supply, restart the ADC by setting the RESTARTADC bit, ADCCON, Bit 6, and wait for 20 ms before starting ADC conversions.

The following function demonstrates how to restart the ADC and set the 20 ms delay:

```
void ResetAdcBlock(void)
{
    pADI_ADC->ADCCON |= 0x40;           // Power down ADC and ADC reference buffer
    delay(20mS);                       // delay 20mS
}
```

Then, measure the AVDD/2 channel to ensure the measured voltage is greater than 2.85 V, as follows:

```
float AdcAvddTest(void)
{
    AdcPinInt(CHAN_AVDD_DIV2);         //select internal AVDD/2 ADC channel
    conversionDone = 0;                // Clear conversion flag
    NVIC_EnableIRQ(ADC_IRQn);         // Enable interrupt
    AdcGo(ENUM_ADC_ADCCON_CONVTYPE_CONT); // ADC continuous conversion

    while(conversionDone==0); //wait for conversion finish
    AdcData = AdcData>>BITP_ADC_ADCDAT_N_DAT;
    iADCDAT = (int16_t)AdcData;
    fAvddVolts = (float)(iADCDAT/65535.0f); // Convert ADC sample to a voltage
    fAvddVolts = (float)( fAvddVolts *2500);
    return fAvddVolts;
}
//Sample ADC interrupt handler
void ADC_Int_Handler()
{
    uint32_t data,sta;

    sta = pADI_ADC->ADCIRQSTAT; //must read to clear status
    if(sta&BITM_ADC_ADCIRQSTAT_CNVRQSTAT) //conversion triggered interrupt
    {
        data = REG_ADC_AVDD_DIV2_DAT21; // Read AVDD/2 channel
        if(!conversionDone)
        {
            AdcData = data;
        }
        conversionDone = 1;
        dataCnt = 0;
        AdcGo(ENUM_ADC_ADCCON_CONVTYPE_IDLE); //stop conversion
    }
}
```

ADC CIRCUIT

REGISTER SUMMARIES: ADC CONTROL, ADC VOLTAGE PROGRAMMABLE GAIN AMPLIFIER (PGA), AND ADC TEMPERATURE SENSOR REGISTERS

Table 27. ADC Register Summary

Address	Name	Description	Reset	Access
0x40068000 to 0x40068074	ADCDATx	ADCDAT Result and Flags for Each ADC Input Channel.	0x00000000	R
0x40068078	ADCCON	ADC Configuration.	0x00000200	R/W
0x4006807C	PREBUFCON	Precharge Buffer Control.	0x00000003	R/W
0x40068080	ADCCNVC	ADC Conversion Cycle for Positive Input AINx Channels.	0x00000010	R/W
0x40068084	ADCCNVCSLOW	ADC Conversion Cycle for Positive Input TIA and Internal Channels.	0x00000140	R/W
0x40068088	ADCCHA	ADC Channel Select.	0x00000000	R/W
0x4006808C	ADCIRQSTAT	ADC Interrupt Status.	0x00000000	R
0x40068090	ADCSEQ	ADC Sequencer Control.	0x00000000	R/W
0x40068094	ADCSEQC	ADC Sequencer Configuration.	0x00000000	R/W
0x40068098	ADCSEQS	ADC Sequencer Status.	0x00000000	R
0x4006809C	ADCSEQCH	ADC Sequencer Channel 0.	0x00000000	R/W
0x400680A0	ADCSEQCHMUX0	ADC Sequencer Channel 1.	0x00000000	R/W
0x400680A4	ADCSEQCHMUX1	ADC Sequencer Channel 1.	0x00000000	R/W
0x400680A8	ADCCMP	Digital Comparator 0 Configuration.	0x00040000	R/W
0x400680AC	ADCCMPIRQSTAT	Digital Comparator Interrupt Status.	0x00000000	R/W
0x400680B0	ADCOFGNDIFF	ADC Offset Gain Differential Channel Error Correction.	Factory calibration value	R/W
0x400680B4	ADCOFTEMP	ADC Offset Gain Temperature Sensor Channel Error Correction.	Factory calibration value	R/W
0x400680B8	ADCNGTEMP	ADC Offset Gain Temperature Sensor Channel Error Correction.	Factory calibration value	R/W
0x400680BC	ADCOFGNPGA0	ADC Offset Gain PGA0 Channel Error Correction.	0x00004000	R/W
0x400680C0	ADCOFGNPGA1	ADC Offset Gain PGA1 Channel Error Correction.	0x00004000	R/W
0x400680C4	ADCOFGNPGA2	ADC Offset Gain PGA2 Channel Error Correction.	0x00004000	R/W
0x400680C8	ADCOFGNPGA3	ADC Offset Gain PGA3 Channel Error Correction.	0x00004000	R/W
0x40068154	ADCCMP1	Digital Comparator 1 Configuration.	0x00040000	R/W
0x40068158	ADCCMP2	Digital Comparator 2 Configuration.	0x00040000	R/W
0x4006815C	ADCCMP3	Digital Comparator 3 Configuration.	0x00040000	R/W

Table 28. PGA Register Summary

Address	Name	Description	Reset	Access
0x40069000	PGABIASCON	PGA Bias Circuit Control Signal Register.	0x0000003F	R/W
0x40069020	PGA0CON	PGA0 Control Register.	0x00000009	R/W
0x40069024	PGA0CHPCON	PGA0 Chop Function Control Register.	0x00000001	R/W
0x40069028	PGA3CHPCON	PGA3 Chop Function Control Register.	0x00000001	R/W
0x40069070	PGA1CON	PGA1 Control Register.	0x00000011	R/W
0x40069074	PGA1CHPCON	PGA1 Chop Function Control Register.	0x00000001	R/W
0x400690A0	PGA2CON	PGA2 Control Register.	0x00000009	R/W
0x400690A4	PGA2CHPCON	PGA2 Chop Function Control Register.	0x00000001	R/W
0x400690D0	PGA3CON	PGA3 Control Register.	0x00000011	R/W

Table 29. Temperature Sensor Register Summary

Address	Name	Description	Reset	Access
0x40069600	TMPNSNCON	Temperature Sensor Control Register.	0x00000002	R/W
0x40069604	TMPNSNSCHPCON	Temperature Sensor channel Chopping Control Register.	0x00000000	R/W

ADC CIRCUIT

REGISTER DETAILS ADC CONTROL, ADC VOLTAGE PROGRAMMABLE GAIN AMPLIFIER (PGA), AND ADC TEMPERATURE SENSOR REGISTERS

ADCx Data and Flags Register

Address: 0x40068000 to 0x40068074 (Increments of 0x04), Reset: 0x00000000, Name: ADCDATx

Table 30. Bit Descriptions for ADCDATx

Bits	Bit Name	Settings	Description	Reset	Access
[31:20]	RESERVED		Reserved.	0x0	R
[19:4]	DAT		ADCx Data. ADC conversion result for each channel. ADCDAT0: AIN0 Channel Data. ADCDAT1: AIN1 Channel Data. ADCDAT2: AIN2 Channel Data. ADCDAT3: AIN3 Channel Data. ADCDAT4: AIN4 Channel Data. ADCDAT5: AIN5 Channel Data. ADCDAT6: AIN6 Channel Data. ADCDAT7: AIN7 Channel Data. ADCDAT8: AIN8 Channel Data. ADCDAT9: AIN9 Channel Data. ADCDAT10: AIN10 Channel Data. ADCDAT11: AIN11 Channel Data. ADCDAT12: AIN12 Channel Data. ADCDAT13: AIN13 Channel Data. ADCDAT14: AIN14 Channel Data. ADCDAT15: AIN15 Channel Data. ADCDAT16: PGA0 Channel Data. ADCDAT17: PGA1 Channel Data. ADCDAT18: PGA2 Channel Data. ADCDAT19: PGA3 Channel Data. ADCDAT20: Temperature Sensor Channel Data. ADCDAT21: AVDD/2 Channel Data. ADCDAT22: IOVDD0/2 Channel Data. ADCDAT23: IOVDD1 Channel Data. ADCDAT24: Reserved. ADCDAT25: Reserved. ADCDAT26: Reserved. ADCDAT27: Reserved. ADCDAT28: Reserved. ADCDAT29: AGND or DVDD/2 Channel Data.	0x0	R
3	RESERVED		Reserved.	0x0	R
2	RDY		Data Read Flag. Flag indicating whether data has already been read. 0 Data is Not Ready or Has Been Read Out. 1 Data is Ready to Be Read.	0x0	R
1	UVF		Underflow Flag. It is meaningless in oversampling mode. 0 Not Underflow. 1 Underflow. Set if the DAT value is zero scale.	0x0	R
0	OVF		Overflow Flag. This bit is meaningless in oversampling mode. 0 Not Overflow.	0x0	R

ADC CIRCUIT

Table 30. Bit Descriptions for ADCDATx (Continued)

Bits	Bit Name	Settings	Description	Reset	Access
		1	Overflow. Set if the DAT value is full scale. May indicate that the input being measured is above the ADC reference voltage.		

ADC Configuration Register

Address: 0x40068078, Reset: 0x00000200, Name: ADCCON

Table 31. Bit Descriptions for ADCCON

Bits	Bit Name	Settings	Description	Reset	Access
[31:20]	RESERVED		Reserved.	0x0	R
[19:15]	GPTEVENTEN		Enable General-Purpose Timer (GPT) Event to Trigger Conversion. Each bit of GPTEVENTEN[4:0] is used independently to enable GPT0, GPT1, GPT2, GPT3, or GPT4 event to trigger ADC conversion. GPTEVENTEN[4]: enable bit for GPT4 event. GPTEVENTEN[3]: enable bit for GPT3 event. GPTEVENTEN[2]: enable bit for GPT2 event. GPTEVENTEN[1]: enable bit for GPT1 event. GPTEVENTEN[0]: enable bit for GPT0 event	0x0	R/W
14	CNVIRQEN	0 1	Enable Conversion Interrupt. 0 Disable interrupt source. 1 Enable interrupt source.	0x0	R/W
13	RESERVED		Reserved.	0x0	R
[12:10]	OSR	000 001 010 011 100 101 110, 111	Oversampling Ratio. 000 Oversampling Disable. ADC output rate controlled by ADCCNVC. 001 Oversampling ×2. ADCCNVC must be ≥0x20. 010 Oversampling ×4. ADCCNVC must be ≥0x40. 011 Oversampling ×8. ADCCNVC must be ≥0x80. 100 Oversampling ×16. ADCCNVC must be ≥0x100. 101 Oversampling ×32. ADCCNVC must be ≥0x200. Limited only to AINx channels. PGA and internal channels not supported with this setting. 110, 111 Oversampling Disable. ADC output rate controlled by ADCCNVC or ADCCNVC SLOW.	0x0	R/W
9	PDADC	0 1	ADC Power-Down. 0 ADC Active. 1 Power Down ADC.	0x1	R/W
8	VDDSEL	0 1	Select Whether Channel 29 is DVDD Channel or AGND Channel. 0 Channel 29 is Half of DVDD Channel. 1 Channel 29 is AGND Channel.	0x0	R/W
7	PDREFBUF	0 1	ADC Reference Buffer Power-Down. 0 Normal Mode. 1 Power Down Reference.	0x0	R/W
6	RESTARTADC	0 1	Restart ADC. 0 No Effect. 1 Write to 1 to Restart the ADC Block. Automatically clears to 0 after write.	0x0	R/W
5	PINMOD	0 1	PIN Conversion Mode (Uses P2.0). 0 Conversion is Controlled by Pin Level. 1 Conversion is Controlled by Pin Edge.	0x0	R/W
4	SEQDMA	1 0	DMA Request Enable for ADC Sequencer Conversions. 1 Enable DMA Request. 0 Disable DMA Request.	0x0	R/W

ADC CIRCUIT

Table 31. Bit Descriptions for ADCCON (Continued)

Bits	Bit Name	Settings	Description	Reset	Access
3	CNVDMA		DMA Request Enable for ADC Conversions (Nonsequencer Based). 1 Enable DMA request. 0 Disable DMA request.	0x0	R/W
[2:0]	CONVTYPE		ADC Conversion Type Selection. 0 No Conversion. ADC is halted. 1 ADC Controlled by GPIO Pin (P2.0). When PINMOD = 0, ADC conversion is controlled by the pin signal level, active low. When PINMOD = 1, ADC conversion is controlled by the falling edge of the pin signal. (Limited to ≤0.8 MSPS update rate.) 10 Software Single Conversion (Limited to ≤0.8 MSPS update rate). 11 Software Continue Conversion. Sequence is working under this mode. 100 PLA Conversion. 101 GPT Triggered Conversion.	0x0	R/W

Precharge Buffer Control Register

Address: 0x4006807C, Reset: 0x00000003, Name: PREBUFCON

Table 32. Bit Descriptions for PREBUFCON

Bits	Bit Name	Settings	Description	Reset	Access
[31:2]	RESERVED		Reserved.	0x0	R
1	PRGBYPN		Bypass N Channel Input Buffer. 0 Enable N Channel Input Buffer. 1 Disable N Channel Input Buffer.	0x1	R/W
0	PRGBYPP		Bypass P Channel Input Buffer. 0 Enable P Channel Input Buffer. 1 Disable P Channel Input Buffer.	0x1	R/W

ADC Conversion Cycle for Positive Input AINx Channels Register

Address: 0x40068080, Reset: 0x00000010, Name: ADCCNVC

Table 33. Bit Descriptions for ADCCNVC

Bits	Bit Name	Settings	Description	Reset	Access
[31:0]	CNVC		Configures the ADC Sampling frequency for Channel AIN0 to Channel AIN15. For example, conversion frequency = 32 MHz/ADCCNVC. Default frequency is 2 MHz. Ensure frequency is ≤2 MHz. Configure ADCCNVC only after setting ADCON, Bits[2:0] to 0x0 to disable the ADC conversion.	0x10	R/W

ADC Conversion Cycle for Positive Input TIA and Internal Channels Register

Address: 0x40068084, Reset: 0x00000140, Name: ADCCNVCSLOW

Table 34. Bit Descriptions for ADCCNVCSLOW

Bits	Bit Name	Settings	Description	Reset	Access
[31:0]	CNVCSLOW		Configures the ADC Sampling frequency for Internal Channels and PGA/TIA Channels. 32 MHz/ADCCNVCSLOW. Default frequency is 100 kSPS. Configure ADCCNVCSLOW only after setting ADCON, Bits[2:0] to 0x0 to disable the ADC conversion. When chopping is enabled, the ADC update frequency is divided by 2.	0x140	R/W

ADC CIRCUIT

ADC Channel Select Register

Address: 0x40068088, Reset: 0x00000000, Name: ADCCHA

Table 35. Bit Descriptions for ADCCHA

Bits	Bit Name	Settings	Description	Reset	Access
[31:9]	RESERVED		Reserved.	0x0	R
[8:5]	ADCCN	0000 ADCREFN. 0001 ADCREFP. 0010 AIN1. 0011 AIN3. 0100 AIN5. 0101 AIN7. 0110 AIN9. 0111 AIN11. 1000 AIN13. 1001 AIN15. 1010 to 1111 ADCREFN.	ADC N Channel Selection. In normal conversion mode, for certain ADCCP configurations, hardware needs ADCCN for further mux selection of N channel.	0x0	R/W
[4:0]	ADCCP	0 AIN0. 1 AIN1. 10 AIN2. 11 AIN3. 100 AIN4. 101 AIN5. 110 AIN6. 111 AIN7. 1000 AIN8. 1001 AIN9. 1010 AIN10. 1011 AIN11. 1100 AIN12. 1101 AIN13. 1110 AIN14. 1111 AIN15. 10000 PGA0. 10001 PGA1. 10010 PGA2. 10011 PGA3. 10100 Internal temperature sensor. 10101 AVDD/2. 10110 IOVDD0/2. 10111 IOVDD1. 11000 to 11100 Reserved. 11101 AGND or DVDD ÷ 2 (see ADCCON, Bit 8). 11110 to 11111 Reserved.	ADC P Channel Selection.	0x0	R/W

ADC CIRCUIT

ADC Interrupt Status Register

Address: 0x4006808C, Reset: 0x00000000, Name: ADCIRQSTAT

Table 36. Bit Descriptions for ADCIRQSTAT

Bits	Bit Name	Settings	Description	Reset	Access
[31:2]	RESERVED		Reserved.	0x0	R
1	SEQIRQSTAT		Sequence Conversion IRQ Status flag. 0 No interrupt/Interrupt Clear. 1 Interrupt Set.	0x0	R
0	CNVIRQSTAT		Single Conversion IRQ Status flag. 0 No interrupt/Interrupt Clear. 1 Interrupt Set.	0x0	R

ADC Sequencer Control Register

Address: 0x40068090, Reset: 0x00000000, Name: ADCSEQ

Table 37. Bit Descriptions for ADCSEQ

Bits	Bit Name	Settings	Description	Reset	Access
[31:4]	RESERVED		Reserved.	0x0	R
3	SEQIRQEN		Enable Sequencer Interrupt Generation. 1 Enable Sequencer interrupts. 0 Disable Sequencer interrupts.	0x0	R/W
2	SEQSTL		Sequencer Stall. 0 Running Sequence. 1 Stalling Sequence.	0x0	R/W
1	SEQREN		Sequence Restart. Sequence restart used to force sequencer to start at first channel when sequence is working. Set to 1 to restart the sequencer. Cleared after writing 1.	0x0	W
0	SEQEN		Sequence Enable. Set to 1 to enable the sequencer. Cleared after writing 1.	0x0	W

ADC Sequencer Configuration Register

Address: 0x40068094, Reset: 0x00000000, Name: ADCSEQC

Table 38. Bit Descriptions for ADCSEQC

Bits	Bit Name	Settings	Description	Reset	Access
[31:8]	RESERVED		Reserved.	0x0	R
[7:0]	SEQT		Repeat Sequence Interval. Define programmable delay of 0 to 254 between sequences. A delay 255 causes a halt after one sequence.	0x0	R/W

ADC Sequencer Status Register

Address: 0x40068098, Reset: 0x00000000, Name: ADCSEQS

Table 39. Bit Descriptions for ADCSEQS

Bits	Bit Name	Settings	Description	Reset	Access
[31:3]	RESERVED		Reserved.	0x0	R
2	SEQSTAT		Sequencer Status. 1 Sequencer is Busy. Sequencer is running/stalled or starting next sequence. 0 Sequence is Idle. Sequencer becomes idle when sequencer is turned off. For a single sequencer, the sequencer is turned off automatically after one sequence loop ends. For repeat sequences, the sequencer is turned off after software configures the SEQT to 255 in the ADCSEQC register. The sequencer cannot be turned off immediately after software configures SEQT to 255. The sequencer cannot be turned off until all the current channels in the sequence loop have ended.	0x0	R

ADC CIRCUIT

Table 39. Bit Descriptions for ADCSEQS (Continued)

Bits	Bit Name	Settings	Description	Reset	Access
1	SEQSTLSTAT		Stall Sequencer Status. 0 Sequence Still Run. 1 Sequence Has Stalled.	0x0	R
0	CNVSTAT		ADC Conversion Idle/Busy Flag. 0 ADC Conversion is Idle. 1 ADC Conversion is Busy.	0x0	R

ADC Sequencer Channel 0 Register

Address: 0x4006809C, Reset: 0x00000000, Name: ADCSEQCH

Table 40. Bit Descriptions for ADCSEQCH

Bits	Bit Name	Settings	Description	Reset	Access
[31:30]	RESERVED		Reserved.	0x0	R
[29:0]	SEQCH		Sequence Channel Selection. SEQCH[0]: Channel 0. SEQCH[1]: Channel 1. ... SEQCH[29]: Channel 29.	0x0	R/W

ADC Sequencer Channel 1 Register

Address: 0x400680A0, Reset: 0x00000000, Name: ADCSEQCHMUX0

Table 41. Bit Descriptions for ADCSEQCHMUX0

Bits	Bit Name	Settings	Description	Reset	Access
[31:30]	RESERVED		Reserved.	0x0	R
29	DIF11		When AIN11 is P Channel in Sequencer Mode, N Channel Mux Selection: 0 ADCREFN. 1 ADCREFFP.	0x0	R/W
[28:25]	DIF10		When AIN10 is P Channel in Sequencer Mode, N Channel Mux Selection: 0 ADCREFN. 1 ADCREFFP. 10 AIN1. 11 AIN3. 100 AIN5. 101 AIN7. 110 AIN9. 111 AIN11. 1000 AIN13. 1001 AIN15. 1010 to 1111 ADCREFN.	0x0	R/W
24	DIF9		When AIN9 is P Channel in Sequencer Mode, N Channel Mux Selection: 0 ADCREFN. 1 ADCREFFP.	0x0	R/W
[23:20]	DIF8		When AIN8 is P Channel in Sequencer Mode, N Channel Mux Selection: 0 ADCREFN. 1 ADCREFFP. 10 AIN1. 11 AIN3.	0x0	R/W

ADC CIRCUIT

Table 41. Bit Descriptions for ADCSEQCHMUX0 (Continued)

Bits	Bit Name	Settings	Description	Reset	Access
		100	AIN5.		
		101	AIN7.		
		110	AIN9.		
		111	AIN11.		
		1000	AIN13.		
		1001	AIN15.		
		1010 to 1111	ADCREFN.		
19	DIF7		When AIN7 is P Channel in Sequencer Mode, N Channel Mux Selection: 0 ADCREFN. 1 ADCREFP.	0x0	R/W
[18:15]	DIF6		When AIN6 is P Channel in Sequencer Mode, N Channel Mux Selection: 0 ADCREFN. 1 ADCREFP. 10 AIN1. 11 AIN3. 100 AIN5. 101 AIN7. 110 AIN9. 111 AIN11. 1000 AIN13. 1001 AIN15. 1010 to 1111 ADCREFN.	0x0	R/W
14	DIF5		When AIN5 is P Channel in Sequencer Mode, N Channel Mux Selection: 0 ADCREFN. 1 ADCREFP.	0x0	R/W
[13:10]	DIF4		When AIN4 is P Channel in Sequencer Mode, N Channel Mux Selection: 0 ADCREFN. 1 ADCREFP. 10 AIN1. 11 AIN3. 100 AIN5. 101 AIN7. 110 AIN9. 111 AIN11. 1000 AIN13. 1001 AIN15. 1010 to 1111 ADCREFN.	0x0	R/W
9	DIF3		When AIN3 is P Channel in Sequencer Mode, N Channel Mux Selection: 0 ADCREFN. 1 ADCREFP.	0x0	R/W
[8:5]	DIF2		When AIN2 is P Channel in Sequencer Mode, N Channel Mux Selection: 0 ADCREFN. 1 ADCREFP. 10 AIN1. 11 AIN3. 100 AIN5. 101 AIN7. 110 AIN9.	0x0	R/W

ADC CIRCUIT

Table 41. Bit Descriptions for ADCSEQCHMUX0 (Continued)

Bits	Bit Name	Settings	Description	Reset	Access
		111	AIN11.		
		1000	AIN13.		
		1001	AIN15.		
		1010 to 1111	ADCREFN.		
4	DIF1		When AIN1 is P Channel in Sequencer Mode, N Channel Mux Selection: 0 ADCREFN. 1 ADCREFF.	0x0	R/W
[3:0]	DIF0		When AIN0 is P Channel in Sequencer Mode, N Channel Mux Selection: 0 ADCREFN. 1 ADCREFF. 10 AIN1. 11 AIN3. 100 AIN5. 101 AIN7. 110 AIN9. 111 AIN11. 1000 AIN13. 1001 AIN15. 1010 to 1111 ADCREFN.	0x0	R/W

ADC Sequencer Channel 1 Register

Address: 0x400680A4, Reset: 0x00000000, Name: ADCSEQCHMUX1

Table 42. Bit Descriptions for ADCSEQCHMUX1

Bits	Bit Name	Settings	Description	Reset	Access
[31:10]	RESERVED		Reserved.	0x0	R
9	DIF15		When AIN15 is P Channel in Sequencer Mode, N Channel Mux Selection: 0 ADCREFN. 1 ADCREFF.	0x0	R/W
[8:5]	DIF14		When AIN14 is P Channel in Sequencer Mode, N Channel Mux Selection: 0 ADCREFN. 1 ADCREFF. 10 AIN1. 11 AIN3. 100 AIN5. 101 AIN7. 110 AIN9. 111 AIN11. 1000 AIN13. 1001 AIN15. 1010 to 1111 ADCREFN.	0x0	R/W
4	DIF13		When AIN13 is P Channel in Sequencer Mode, N Channel Mux Selection: 0 ADCREFN. 1 ADCREFF.	0x0	R/W
[3:0]	DIF12		When AIN12 is P Channel in Sequencer Mode, N Channel Mux Selection: 0 ADCREFN. 1 ADCREFF. 10 AIN1.	0x0	R/W

ADC CIRCUIT

Table 42. Bit Descriptions for ADCSEQCHMUX1 (Continued)

Bits	Bit Name	Settings	Description	Reset	Access
		11	AIN3.		
		100	AIN5.		
		101	AIN7.		
		110	AIN9.		
		111	AIN11.		
		1000	AIN13.		
		1001	AIN15.		
		1010 to 1111	ADCREFN.		

Digital Comparator 0, Comparator 1, Comparator 2, and Comparator 3 Configuration Registers

Address: 0x400680A8, Reset: 0x00040000, Name: ADCCMP

Address: 0x40068154, Reset: 0x00040000, Name: ADCCMP1

Address: 0x40068158, Reset: 0x00040000, Name: ADCCMP2

Address: 0x40068158, Reset: 0x00040000, Name: ADCCMP3

Table 43. Bit Descriptions for ADCCMP, ADCCOMP1, ADCCOMP2, ADCCOMP3

Bits	Bit Name	Settings	Description	Reset	Access
[31:24]	RESERVED		Reserved.	0x0	R
[23:19]	CH		Channel Index for Data Comparison. List matches ADCCP bits in the ADCCHA register (see Table 35).	0x0	R/W
		00000	AIN0.		
		00001	AIN1.		
			
		11101	AGND.		
18	IRQEN		Enable IRQ Generation.	0x1	R/W
		1	Enable.		
		0	Disable.		
[17:2]	THR		Compare Threshold Value. Threshold value for comparison.	0x0	R/W
1	CMPDIR		Select Digital Comparator Direction.	0x0	R/W
		0	Generate interrupt if smaller than or equal to threshold value.		
		1	Generate interrupt if greater than threshold value.		
0	EN		Digital Comparator Enable.	0x0	R/W
		0	Disable Comparator.		
		1	Enable Comparator.		

Digital Comparator Interrupt Status Register

Address: 0x400680AC, Reset: 0x00000000, Name: ADCCMPIRQSTAT

Table 44. Bit Descriptions for ADCCMPIRQSTAT

Bits	Bit Name	Settings	Description	Reset	Access
[31:12]	RESERVED		Reserved	0x0	R
11	COMP3PLACLR		Comparator 3 to PLA Interrupt Clear	0x0	R/W
10	COMP2PLACLR		Comparator 2 to PLA Clear	0x0	R/W
9	COMP1PLACLR		Comparator 1 to PLA Clear	0x0	R/W
8	COMP0PLACLR		Comparator 0 to PLA Clear	0x0	R/W
7	COMP3IRQCLR		Comparator 3 Interrupt Clear	0x0	R/W
6	COMP2IRQCLR		Comparator 2 Interrupt Clear	0x0	R/W

ADC CIRCUIT

Table 44. Bit Descriptions for ADCCMPIRQSTAT (Continued)

Bits	Bit Name	Settings	Description	Reset	Access
5	COMP1IRQCLR		Comparator 1 Interrupt Clear	0x0	R/W
4	COMP0IRQCLR		Comparator 0 Interrupt Clear	0x0	R/W
3	COMP3IRQSTA		Comparator 3 Interrupt Status	0x0	R
2	COMP2IRQSTA		Comparator 2 Interrupt Status	0x0	R
1	COMP1IRQSTA		Comparator 1 Interrupt Status	0x0	R
0	COMP0IRQSTA		Comparator 0 Interrupt Status	0x0	R

ADC Offset Gain Differential Channel Error Correction Register

Address: 0x400680B0, Reset: 0x00004000, Name: ADCOFGNDIFF

Table 45. Bit Descriptions for ADCOFGNDIFF

Bits	Bit Name	Settings	Description	Reset	Access
[31:15]	OFFSET		Offset Error Correction. Signed number, twos complement form: $Offset\ Factor = 4\ fractional\ bits + 12\ MSB\ bit + 1\ sign\ bit$	0x0	R/W
[14:0]	GAIN		Gain Error Correction. Unsigned number: $Gain\ Factor = (2^{19} - 16,384 + Gain[14:0])/2^{19}$	0x4000	R/W

ADC Offset Gain Temperature Sensor Channel Error Correction Register

Address: 0x400680B4, Reset: 0x00000000, Name: ADCOFTEMP

Table 46. Bit Descriptions for ADCOFTEMP

Bits	Bit Name	Settings	Description	Reset	Access
[31:17]	RESERVED		Reserved.	0x0	R
[16:0]	OFFSET		Offset Error Correction. Signed number, twos complement form: $Offset\ Factor = 4\ fractional\ bits + 12\ MSB\ bit + 1\ sign\ bit$	0x0	R/W

ADC Offset Gain Temperature Sensor Channel Error Correction Register

Address: 0x400680B8, Reset: 0x00080000, Name: ADCGNTEMP

Table 47. Bit Descriptions for ADCGNTEMP

Bits	Bit Name	Settings	Description	Reset	Access
[31:20]	RESERVED		Reserved.	0x0	R
[19:0]	GAIN		Gain Error Correction. Unsigned number: $Gain\ Factor = Gain[19:0]/2^{19}$	0x80000	R/W

ADC Offset Gain PGA0 Channel Error Correction Register

Address: 0x400680BC, Reset: 0x00004000, Name: ADCOFGNPGA0

Table 48. Bit Descriptions for ADCOFGNPGA0

Bits	Bit Name	Settings	Description	Reset	Access
[31:15]	RESERVED		Reserved.	0x0	R
[14:0]	GAIN		Gain Error Correction. Additional gain correction. Unsigned number: $Gain\ Factor = (2^{19} - 16,384 + Gain[14:0])/2^{19}$	0x4000	R/W

ADC Offset Gain PGA1 Channel Error Correction Register

Address: 0x400680C0, Reset: 0x00004000, Name: ADCOFGNPGA1

Table 49. Bit Descriptions for ADCOFGNPGA1

Bits	Bit Name	Settings	Description	Reset	Access
[31:15]	RESERVED		Reserved.	0x0	R

ADC CIRCUIT

Table 49. Bit Descriptions for ADCOFGNPGA1 (Continued)

Bits	Bit Name	Settings	Description	Reset	Access
[14:0]	GAIN		Gain Error Correction. Additional gain correction Unsigned number: $Gain Factor = (2^{19} - 16,384 + Gain[14:0])/2^{19}$	0x4000	R/W

ADC Offset Gain PGA2 Channel Error Correction Register

Address: 0x400680C4, Reset: 0x00004000, Name: ADCOFGNPGA2

Table 50. Bit Descriptions for ADCOFGNPGA2

Bits	Bit Name	Settings	Description	Reset	Access
[31:15]	RESERVED		Reserved.	0x0	R
[14:0]	GAIN		Gain Error Correction. Additional gain correction Unsigned number: $Gain Factor = (2^{19} - 16,384 + Gain[14:0])/2^{19}$	0x4000	R/W

ADC Offset Gain PGA3 Channel Error Correction Register

Address: 0x400680C8, Reset: 0x00004000, Name: ADCOFGNPGA3

Table 51. Bit Descriptions for ADCOFGNPGA3

Bits	Bit Name	Settings	Description	Reset	Access
[31:15]	RESERVED		Reserved.	0x0	R
[14:0]	GAIN		Gain Error Correction. Additional gain correction Unsigned number: $Gain Factor = (2^{19} - 16,384 + Gain[14:0])/2^{19}$	0x4000	R/W

PGA Bias Circuit Control Signal Register

Address: 0x40069000, Reset: 0x0000003F, Name: PGABIASCON

Table 52. Bit Descriptions for PGABIASCON

Bits	Bit Name	Settings	Description	Reset	Access
[31:6]	RESERVED		Reserved.	0x0	R
5	PD3BUF1P25		PGA Channel 3 Common-Mode Buffer Power-Down Control. 0 1.25 V Buffer Enable. 1 1.25 V Buffer Power-Down.	0x1	R/W
4	PD2BUF1P25		PGA Channel 2 Common-Mode Buffer Power-Down Control. 0 1.25 V Buffer Enable. 1 1.25 V Buffer Power-Down.	0x1	R/W
3	PD1BUF1P25		PGA Channel 1 Common-Mode Buffer Power-Down Control. 0 1.25 V Buffer Enable. 1 1.25 V Buffer Power-Down.	0x1	R/W
2	PD0BUF1P25		PGA Channel 0 Common-Mode Buffer Power-Down Control. 0 1.25 V Buffer Enable. 1 1.25 V Buffer Power-Down.	0x1	R/W
1	PD2BUF0P2		PGA Channel 2 200 mV Common-Mode Buffer Power-Down Control. 0 200 mV Buffer Enable. 1 200 mV Buffer Power-Down.	0x1	R/W
0	PD0BUF0P2		PGA Channel 0 200 mV Common-Mode Buffer Power-Down Control. 0 200 mV Buffer Enable. 1 200 mV Buffer Power-Down.	0x1	R/W

ADC CIRCUIT

PGA0 Control Register

Address: 0x40069020, Reset: 0x00000009, Name: PGA0CON

Table 53. Bit Descriptions for PGA0CON

Bits	Bit Name	Settings	Description	Reset	Access
[31:8]	RESERVED		Reserved.	0x0	R
14	DRVEN	0 1	Sink Current Increase in TIA Mode. 0 Normal Drive. 1 Enable Current Sink Boost.	0x0	R/W
[12:11]	TIAVDACSEL	0 1 10 11	TIA Bias Voltage (V_{BIAS}) Selection. TIA can select VDAC8, VDAC 9, VDAC 10, or VDAC 11 as V_{BIAS} . 0 Select VDAC8 as TIA V_{BIAS} . 1 Select VDAC9 as TIA V_{BIAS} . 10 Select VDAC10 as TIA V_{BIAS} . 11 Select VDAC11 as TIA V_{BIAS} .	0x0	R/W
[10:8]	TIAGAIN	0 1 10 11 100 101 110	TIA Gain Resistor Configuration. 0 $R_{TIA} = 250 \Omega$. 1 $R_{TIA} = 750 \Omega$. 10 $R_{TIA} = 2 \text{ k}\Omega$. 11 $R_{TIA} = 5 \text{ k}\Omega$. 100 $R_{TIA} = 10 \text{ k}\Omega$. 101 $R_{TIA} = 20 \text{ k}\Omega$. 110 $R_{TIA} = 100 \text{ k}\Omega$.	0x0	R/W
[7:5]	PGAGAIN	0 1 10 11 100 101	PGA Gain Configuration. 0 Gain = 1. 1 Gain = 2. 10 Gain = 4. 11 Gain = 6. 100 Gain = 8. 101 Gain = 10.	0x0	R/W
4	Reserved		Reserved.	0x0	R/W
3	CAPBYPASS	1 0	Bypass the External Capacitor. PGA has external capacitor option to filter noise. Capacitor can be bypassed or selected. 1 Bypass the External Capacitor. 0 Select the External Capacitor.	0x1	R/W
2	PGAMODE	0 1	PGA DC Mode or AC Mode Select. 0 PGA DC Mode Enable. 1 PGA AC Mode Enable.	0x0	R/W
1	MODE	0 1	PGA or TIA Mode Selection. 0 PGA Mode Enable. 1 TIA Mode Enable.	0x0	R/W
0	PDPGACORE	0 1	PGA Core Power-Down. 0 Enable the PGA. 1 Power Down the PGA.	0x1	R/W

ADC CIRCUIT

PGA0 Chop Function Control Register

Address: 0x24, Reset: 0x00000001, Name: PGA0CHPCON

Table 54. Bit Descriptions for PGA0CHPCON

Bits	Bit Name	Settings	Description	Reset	Access
[31:1]	RESERVED		Reserved.	0x0	R
0	CHOPOFF		Disable Chop Function. PGA has chop function to reduce offset. Function can be disabled. 0 Enable Chop Function. Recommended setting. Results in 2× increase in ADC sample time. 1 Disable Chop Function.	0x1	R/W

PGA1 Control Register

Address: 0x70, Reset: 0x00000011, Name: PGA1CON

Table 55. Bit Descriptions for PGA1CON

Bits	Bit Name	Settings	Description	Reset	Access
[31:15]	RESERVED		Reserved.	0x0	R
14	DRVEN		Sink Current increase in TIA Mode. 0 Normal Drive. 1 Enable Current Sink Boost.	0x0	R/W
[13:8]	RESERVED		Reserved.	0x0	R/W
[12:11]	TIADVACSEL		TIA V_{BIAS} Selection. TIA can select VDACC8, VDACC9, VDACC10, or VDACC11 as V_{BIAS} . 0 Select VDACC8 as TIA V_{BIAS} . 1 Select VDACC9 as TIA V_{BIAS} . 10 Select VDACC10 as TIA V_{BIAS} . 11 Select VDACC11 as TIA V_{BIAS} .	0x0	R/W
[10:8]	TIAGAIN		TIA Gain Configuration. TIA has 250 Ω , 750 Ω , 2 k Ω , 5 k Ω , 10 k, 20 k Ω , or 100 k Ω resistor value selection. 0 $R_{TIA} = 250 \Omega$. 1 $R_{TIA} = 750 \Omega$. 10 $R_{TIA} = 2 \text{ k}\Omega$. 11 $R_{TIA} = 5 \text{ k}\Omega$. 100 $R_{TIA} = 10 \text{ k}\Omega$. 101 $R_{TIA} = 20 \text{ k}\Omega$. 110 $R_{TIA} = 100 \text{ k}\Omega$.	0x0	R/W
[7:5]	PGAGAIN		PGA Gain Configuration. PGA gain can be configured as 1, 2, 4, 6, 8, or 10. 0 Gain = 1. 1 Gain = 2. 10 Gain = 4. 11 Gain = 6. 100 Gain = 8. 101 Gain = 10.	0x0	R/W
[4:3]	RESERVED		Reserved.	0x1	R/W
2	PGAMODE		PGA DC Mode or AC Mode Select. 0 PGA DC Mode Enable. 1 PGA AC Mode Enable.	0x0	R/W
1	MODE		PGA or TIA Mode Selection. 0 PGA Mode Enable. 1 TIA Mode Enable.	0x0	R/W
0	PDPGACORE		PGA Core Power Down. 0 Enable the PGA.	0x1	R/W

ADC CIRCUIT

Table 55. Bit Descriptions for PGA1CON (Continued)

Bits	Bit Name	Settings	Description	Reset	Access
		1	Power Down the PGA.		

PGA1 Chop Function Control Register

Address: 0x74, Reset: 0x00000001, Name: PGA1CHPCON

Table 56. Bit Descriptions for PGA1CHPCON

Bits	Bit Name	Settings	Description	Reset	Access
[31:1]	RESERVED		Reserved.	0x0	R
0	CHOPOFF	0	Disable Chop Function. PGA has chop function to reduce offset, can be disabled.	0x1	R/W
		1	Enable Chop Function. Recommended setting. Results in 2× increase in ADC sample time.		
		1	Disable Chop Function.		

PGA2 Control Register

Address: 0xA0, Reset: 0x00000019, Name: PGA2CON

Table 57. Bit Descriptions for PGA2CON

Bits	Bit Name	Settings	Description	Reset	Access
[31:15]	RESERVED		Reserved.	0x0	R
14	DRVEN	0	Sink Current Increase in TIA Mode.	0x0	R/W
		1	Normal Drive.		
		1	Enable Current Sink Boost.		
[13:8]	RESERVED		Reserved.	0x0	R/W
[12:11]	TIADACSEL	0	TIA V_{BIAS} Selection. TIA can select VDAC8, VDAC9, VDAC10, or VDAC11 as V_{BIAS} .	0x0	R/W
		1	Select VDAC8 as TIA V_{BIAS} .		
		10	Select VDAC9 as TIA V_{BIAS} .		
		11	Select VDAC10 as TIA V_{BIAS} .		
		11	Select VDAC11 as TIA V_{BIAS} .		
[10:8]	TIAGAIN	0	TIA Gain Configuration. TIA has 250 Ω , 750 Ω , 2 k Ω , 5 k Ω , 10 k, 20 k Ω , or 100 k Ω resistor value selection.	0x0	R/W
		1	$R_{TIA} = 250 \Omega$.		
		10	$R_{TIA} = 750 \Omega$.		
		11	$R_{TIA} = 2 \text{ k}\Omega$.		
		100	$R_{TIA} = 5 \text{ k}\Omega$.		
		101	$R_{TIA} = 10 \text{ k}\Omega$.		
		110	$R_{TIA} = 20 \text{ k}\Omega$.		
		111	$R_{TIA} = 100 \text{ k}\Omega$.		
[7:5]	PGAGAIN	0	PGA Gain Configuration. PGA gain can be configured as 1, 2, 4, 6, 8, or 10.	0x0	R/W
		1	Gain = 1.		
		10	Gain = 2.		
		11	Gain = 4.		
		100	Gain = 6.		
		101	Gain = 8.		
		110	Gain = 10.		
4	Reserved		Reserved.	0x1	R/W
3	CAPBYPASS	1	Bypass the External Capacitor. PGA has external capacitor option to filter noise. Capacitor can be bypassed or selected.	0x1	R/W
		0	Bypass the External Capacitor.		
		0	Select the External Capacitor.		

ADC CIRCUIT

Table 57. Bit Descriptions for PGA2CON (Continued)

Bits	Bit Name	Settings	Description	Reset	Access
2	PGAMODE		PGA DC Mode or AC Mode Select. 0 PGA DC Mode Enable. 1 PGA AC Mode Enable.	0x0	R/W
1	MODE		PGA or TIA Mode Selection. 0 PGA Mode Enable. 1 TIA Mode Enable.	0x0	R/W
0	PDPGACORE		PGA Core Power-Down. 0 Enable the PGA. 1 Power Down the PGA	0x1	R/W

PGA2 Chop Function Control Register

Address: 0xA4, Reset: 0x00000001, Name: PGA2CHPCON

Table 58. Bit Descriptions for PGA2CHPCON

Bits	Bit Name	Settings	Description	Reset	Access
[31:1]	RESERVED		Reserved.	0x0	R
0	CHOPOFF		Disable Chop Function. PGA has chop function to reduce offset. Function can be disabled. 0 Enable Chop Function. Recommended setting. Results in 2 \times increase in ADC sample time. 1 Disable Chop Function.	0x1	R/W

PGA3 Control Register

Address: 0xD0, Reset: 0x00000011, Name: PGA3CON

Table 59. Bit Descriptions for PGA3CON

Bits	Bit Name	Settings	Description	Reset	Access
[31:15]	RESERVED		Reserved.	0x0	R
14	DRVEN		Sink Current increase in TIA Mode. 0 Normal Drive. 1 Enable Current Sink Boost.	0x0	R/W
[13:8]	RESERVED		Reserved.	0x0	R/W
[12:11]	TIAVDACSEL		TIA V_{BIAS} Selection. TIA can select VDAC8, VDAC9, VDAC10, or VDAC11 as V_{BIAS} . 0 Select VDAC8 as TIA V_{BIAS} . 1 Select VDAC9 as TIA V_{BIAS} . 10 Select VDAC10 as TIA V_{BIAS} . 11 Select VDAC11 as TIA V_{BIAS} .	0x0	R/W
[10:8]	TIAGAIN		TIA Gain Configuration. TIA has 250 Ω , 750 Ω , 2 k Ω , 5 k Ω , 10 k, 20 k Ω , or 100 k Ω resistor value selection. 0 $R_{TIA} = 250 \Omega$. 1 $R_{TIA} = 750 \Omega$. 10 $R_{TIA} = 2 \text{ k}\Omega$. 11 $R_{TIA} = 5 \text{ k}\Omega$. 100 $R_{TIA} = 10 \text{ k}\Omega$. 101 $R_{TIA} = 20 \text{ k}\Omega$. 110 $R_{TIA} = 100 \text{ k}\Omega$.	0x0	R/W
[7:5]	PGAGAIN		PGA Gain Configuration. PGA gain can be configured as 1, 2, 4, 6, 8, or 10. 0 Gain = 1. 1 Gain = 2. 10 Gain = 4.	0x0	R/W

ADC CIRCUIT

Table 59. Bit Descriptions for PGA3CON (Continued)

Bits	Bit Name	Settings	Description	Reset	Access
		11	Gain = 6.		
		100	Gain = 8.		
		101	Gain = 10.		
[4:3]	RESERVED		Reserved.	0x1	R/W
2	PGAMODE		PGA DC Mode or AC Mode Select.	0x0	R/W
		0	PGA DC Mode Enable.		
		1	PGA AC Mode Enable.		
1	MODE		PGA or TIA Mode Selection.	0x0	R/W
		0	PGA Mode Enable.		
		1	TIA Mode Enable.		
0	PDPGACORE		PGA Core Power-Down.	0x1	R/W
		0	Enable the PGA.		
		1	Power Down the PGA		

PGA3 Chop Function Control Register

Address: 0x28, Reset: 0x00000001, Name: PGA3CHPCON

Table 60. Bit Descriptions for PGA3CHPCON

Bits	Bit Name	Settings	Description	Reset	Access
[31:1]	RESERVED		Reserved.	0x0	R
0	CHOPOFF		Disable Chop Function. PGA has chop function to reduce offset. Function can be disabled.	0x1	R/W
		0	Enable Chop Function. Recommended setting. Results in 2x increase in ADC sample time.		
		1	Disable Chop Function.		

Temperature Sensor Enable Register

Address: 0x40069600, Reset: 0x00000002, Name: TMPNSNCON

Table 61. Bit Descriptions for TMPNSNCON

Bits	Bit Name	Settings	Description	Reset	Access
[31:2]	RESERVED		Reserved.	0x0	R
1	ENTMPNSNS		Temperature Sensor Enable Bit.	0x1	R/W
		0	Disable Temperature Sensor Channel.		
		1	Enable Temperature Sensor Channel.		
0	RESERVED		Reserved.	0x0	R

Temperature Sensor Chop Control Register

Address: 0x40069604, Reset: 0x00000000, Name: TMPNSNSCHPCON

Table 62. Bit Descriptions for TMPNSNSCHPCON

Bits	Bit Name	Settings	Description	Reset	Access
[31:1]	RESERVED		Reserved.	0x0	R
0	CHOFFTMPNSNS		Chopping Control Bit.	0x0	R/W
		0	Enable Temperature Sensor Channel Chopping.		
		1	Disable Temperature Sensor Chopping.		

VOLTAGE REFERENCES

The ADuCM410 and ADuCM420 contain a 2.5 V, internal, band gap-based voltage reference source. Internal buffers connect this reference source to the ADC and the string DACs. The ADC reference requires a 4.7 μ F capacitor connected between the ADCREFP and ADCREFN pins.

EXTERNAL ADC REFERENCE DETAILS

An option exists to connect an external voltage reference for the ADC.

To select an external reference source, follow these steps:

1. Connect the external reference to the ADCREFP and ADCREFN pins.
2. Power down the internal reference by setting ADCCON, Bit 7 = 1.
3. Restart the ADC by setting ADCCON, Bit 6 = 1 (RESTARTADC bit).

Buffered Reference Voltage Output Details

The AIN14/COM3P/BUF0_VREF and AIN15/COM3N/BUF1_VREF pins can optionally be configured as buffered reference voltage outputs. By default, both pins are inputs. To configure these pins as reference voltage outputs, configure the VCMBUFCON register appropriately.

The output voltage for each pin can be individually configured to output 1.25 V or 2.5 V.

Address: 0x40069610, Reset: 0x00000013, Name: VCMBUFCON

Table 63. Bit Descriptions for VCMBUFCON

Bits	Bit Name	Settings	Description	Reset	Access
[31:5]	RESERVED		Reserved.	0x0	R
4	MUXSEL1		Select 2.5 V or 1.25 V. 0 Buffer 1 output = 2.5 V. 1 Buffer 1 output = 1.25 V.	0x1	R/W
3	RESERVED		Reserved.	0x0	R/W
2	MUXSEL0		Select 2.5 V or 1.25 V. 0 Buffer 0 output = 2.5 V. 1 Buffer 0 output = 1.25 V.	0x0	R/W
1	PDBUF1		Power-Down Unit Gain Buffer 1. 0 Enable Buffer 1 output. 1 Disable Buffer 1 output.	0x1	R/W
0	PDBUF0		Power-Down Unit Gain Buffer 0. 0 Enable Buffer 0 output. 1 Disable Buffer 0 output.	0x1	R/W

ANALOG COMPARATORS

The ADuCM410 and ADuCM420 contain four analog comparators.

ANALOG COMPARATORS FEATURES

Each analog comparator compares two analog signals and gives an output indicating which of the input signals is higher. Each comparator output can generate an interrupt and is connected to a PLA element.

ANALOG COMPARATOR OVERVIEW

For the negative input options of the Comparator 0 pin, see COMPCON0, Bits[12:10], and for the positive input options, see COMPCON0, Bits[15:13]. The output pin is P0.0/SCLK0/COMOUT0/PLAI0.

For the negative input options of the Comparator 1 pin, see COMPCON1, Bits[12:10], and for the positive input options, see COMPCON1, Bits[15:13]. The output pin is P0.1/MISO0/COMOUT1/PLAI1.

For the negative input options of the Comparator 2 pin, see COMPCON2, Bits[12:10], and for the positive input options, see COMPCON2, Bits[15:13]. The output pin is P1.0/SIN1/COMOUT2/PLAI4.

For the negative input options of the Comparator 3 pin, see COMPCON3, Bits[12:10], and for the positive input options, see COMPCON3, Bits[15:13]. The output pin is P1.1/SOUT1/COMOUT3/PLAI5.

The comparator outputs are connected to the interrupt logic and can be used as described in the [System Exceptions and Peripheral Interrupts](#) section.

ANALOG COMPARATOR OPERATION

If required, change the hysteresis for each comparator via COMPCONx, Bits[4:0]. COMPCONx, Bit 7 selects the output polarity.

Enable the comparator with COMPCONx, Bit 17.

REGISTER SUMMARY: ANALOG COMPARATORS

Table 64. COMP Register Summary

Address	Name	Description	Reset	Access
0x40068A00	COMPCON0	Analog Comparator 0 Control Register.	0x00000060	R/W
0x40068A04	COMPCON1	Analog Comparator 1 Control Register.	0x00000060	R/W
0x40068A08	COMPCON2	Analog Comparator 1 Control Register.	0x00000060	R/W
0x40068A0C	COMPCON3	Analog Comparator 1 Control Register.	0x00000060	R/W
0x40068A10	COMPIRQSTAT	Analog Comparators Interrupt Status Register.	0x00000000	R

REGISTER DETAILS: ANALOG COMPARATORS

Address: 0x40068A00, Reset: 0x00000060, Name: COMPCON0

Table 65. Bit Descriptions for COMPCON0

Bits	Bit Name	Settings	Description	Reset	Access
[31:21]	RESERVED		Reserved.	0x0	R
[20:19]	INTMODE		Interrupt Mode. 0 Generate interrupt if rising edge happens. 1 Generate interrupt if falling edge happens. 10 Reserved. 11 Reserved.	0x0	R/W
18	INTEN		Interrupt Enable.	0x0	R/W
17	EN		Enable Comparator.	0x0	R/W
16	RESERVED		Reserved. Leave as 0.	0x0	R/W

ANALOG COMPARATORS

Table 65. Bit Descriptions for COMPCON0 (Continued)

Bits	Bit Name	Settings	Description	Reset	Access
[15:13]	INPOS		Select Comparator Positive Input Source. 0 All input switches off. 1 Enable AIN8. 10 Enable PGA0. 11 Enable P0.6.	0x0	R/W
[12:10]	INNEG		Select Comparator Negative Input Source. 000 All input switches off. 001 Enable half AVDD input. 010 Enable AIN9. 011 Enable VDAC8 input. 100 Enable VDAC9 input. 101 Enable VDAC10 input. 110 Enable VDAC11 input. 111 Enable 1.25 V reference input from AIN15/COM3N/BUF1_VREF. WLCSP device does not support it.	0x0	R/W
9	Reserved		Reserved.	0x0	R/W
8	Reserved		Reserved. Always leave as 0.	0x0	R/W
7	INV		Select Output Logic State. 0 Output is high if + (positive) input is higher than - (negative) input. 1 Output is high if - (negative) is higher than + (positive) input.	0x0	R/W
[6:5]	RESERVED		Reserved.	0x3	R/W
[4:0]	HYS		Comparator Hysteresis Bits. 0 Hysteresis disabled. 1 10 mV hysteresis enabled. 10 25 mV hysteresis. 11 35 mV hysteresis. 110 50 mV hysteresis. 111 60 mV hysteresis. 1100 75 mV hysteresis. 1101 85 mV hysteresis. 1110 100 mV hysteresis. 10001 110 mV hysteresis. 10010 125 mV hysteresis. 10011 135 mV hysteresis. 10110 150 mV hysteresis. 10111 160 mV hysteresis. 11100 175 mV hysteresis. 11101 185 mV hysteresis. 11110 200 mV hysteresis. 11111 210 mV hysteresis.	0x0	R/W

Address: 0x40068A04, Reset: 0x00000060, Name: COMPCON1

Table 66. Bit Descriptions for COMPCON1

Bits	Bit Name	Settings	Description	Reset	Access
[31:21]	RESERVED		Reserved.	0x0	R

ANALOG COMPARATORS

Table 66. Bit Descriptions for COMPCON1 (Continued)

Bits	Bit Name	Settings	Description	Reset	Access
[20:19]	INTMODE		Interrupt Mode. 0 Generate interrupt if rising edge happens. 1 Generate interrupt if falling edge happens. 10 Reserved. 11 Reserved.	0x0	R/W
18	INTEN		Interrupt Enable.	0x0	R/W
17	EN		Enable Comparator.	0x0	R/W
16	RESERVED		Reserved. Leave as 0.	0x0	R/W
[15:13]	INPOS		Select Comparator Positive Input Source. 0 All input switches off. 1 Enable AIN10. 10 Enable PGA1. 11 Enable P0.7.	0x0	R/W
[12:10]	INNEG		Select Comparator Negative Input Source. 000 All input switches off. 001 Enable Half AVDD input. 010 Enable AIN11. 011 Enable VDAC8 input. 100 Enable VDAC9 input. 101 Enable VDAC10 input. 110 Enable VDAC11 input. 111 Enable 1.25 V reference input from AIN15/COM3N/BUF1_VREF. WLCSP device does not support it.	0x0	R/W
9	Reserved		Reserved.	0x0	R/W
8	Reserved		Reserved. Always leave as 0.	0x0	R/W
7	INV		Select Output Logic State. 0 Output is high if + (positive) input is higher than - (negative) input. 1 Output is high if - (negative) is higher than + (positive) input.	0x0	R/W
[6:5]	RESERVED		Reserved.	0x3	R/W
[4:0]	HYS		Comparator Hysteresis Bits. 0 Hysteresis disabled. 1 10 mV hysteresis enabled. 10 25 mV hysteresis. 11 35 mV hysteresis. 110 50 mV hysteresis. 111 60 mV hysteresis. 1100 75 mV hysteresis. 1101 85 mV hysteresis. 1110 100 mV hysteresis. 10001 110 mV hysteresis. 10010 125 mV hysteresis. 10011 135 mV hysteresis. 10110 150 mV hysteresis. 10111 160 mV hysteresis. 11100 175 mV hysteresis. 11101 185 mV hysteresis. 11110 200 mV hysteresis. 11111 210 mV hysteresis.	0x0	R/W

ANALOG COMPARATORS

Address: 0x40068A08, Reset: 0x00000060, Name: COMPCON2

Table 67. Bit Descriptions for COMPCON2

Bits	Bit Name	Settings	Description	Reset	Access
[31:21]	RESERVED		Reserved.	0x0	R
[20:19]	INTMODE	0 Generate interrupt if rising edge happens. 1 Generate interrupt if falling edge happens. 10 Reserved. 11 Reserved.	Interrupt Mode.	0x0	R/W
18	INTEN		Interrupt Enable.	0x0	R/W
17	EN		Enable Comparator.	0x0	R/W
16	RESERVED		Reserved. Leave as 0.	0x0	R/W
[15:13]	INPOS	0 All input switches off. 1 Enable AIN12. 10 Enable PGA2. 11 Enable P2.0.	Select Comparator Positive Input Source.	0x0	R/W
[12:10]	INNEG	000 All input switches off. 001 Enable Half AVDD input. 010 Enable AIN13. 011 Enable VDAC8 input. 100 Enable VDAC9 input. 101 Enable VDAC10 input. 110 Enable VDAC11 input. 111 Enable 1.25 V reference input from AIN15/COM3N/BUF1_VREF. WLCSP device does not support it.	Select Comparator Negative Input Source.	0x0	R/W
9	Reserved		Reserved.	0x0	R/W
8	Reserved		Reserved. Always leave as 0.	0x0	R/W
7	INV	0 Output is high if + (positive) input is higher than - (negative) input. 1 Output is high if - (negative) is higher than + (positive) input.	Select Output Logic State.	0x0	R/W
[6:5]	RESERVED		Reserved.	0x3	R/W
[4:0]	HYS	0 Hysteresis disabled. 1 10 mV hysteresis enabled. 10 25 mV hysteresis. 11 35 mV hysteresis. 110 50 mV hysteresis. 111 60 mV hysteresis. 1100 75 mV hysteresis. 1101 85 mV hysteresis. 1110 100 mV hysteresis. 10001 110 mV hysteresis. 10010 125 mV hysteresis. 10011 135 mV hysteresis. 10110 150 mV hysteresis. 10111 160 mV hysteresis. 11100 175 mV hysteresis. 11101 185 mV hysteresis. 11110 200 mV hysteresis.	Comparator Hysteresis Bits.	0x0	R/W

ANALOG COMPARATORS

Table 67. Bit Descriptions for COMPCON2 (Continued)

Bits	Bit Name	Settings	Description	Reset	Access
		11111	210 mV hysteresis.		

Address: 0x40068A0C, Reset: 0x00000060, Name: COMPCON3

Table 68. Bit Descriptions for COMPCON3

Bits	Bit Name	Settings	Description	Reset	Access
[31:21]	RESERVED		Reserved.	0x0	R
[20:19]	INTMODE	0 1 10 11	Interrupt Mode. Generate interrupt if rising edge happens. Generate interrupt if falling edge happens. Reserved. Reserved.	0x0	R/W
18	INTEN		Interrupt Enable.	0x0	R/W
17	EN		Enable Comparator.	0x0	R/W
16	RESERVED		Reserved. Leave as 0.	0x0	R/W
[15:13]	INPOS	0 1 10 11	Select Comparator Positive Input Source. All input switches off. Enable AIN14. Enable PGA3 output. Enable P2.1.	0x0	R/W
[12:10]	INNEG	000 001 010 011 100 101 110 111	Select Comparator Negative Input Source. All input switches off. Enable half AVDD input. Enable AIN15 Enable VDAC8 input. Enable VDAC9 input. Enable VDAC10 input. Enable VDAC11 input. Enable 1.25 V reference input from AIN15/COM3N/BUF1_VREF. WLCSP device does not support it.	0x0	R/W
9	Reserved		Reserved.	0x0	R/W
8	Reserved		Reserved. Always leave as 0.	0x0	R/W
7	INV	0 1	Select Output Logic State. Output is high if + (positive) input is higher than - (negative) input. Output is high if - (negative) is higher than + (positive) input.	0x0	R/W
[6:5]	RESERVED		Reserved.	0x3	R/W
[4:0]	HYS	0 1 10 11 110 111 1100 1101 1110 10001 10010 10011 10110	Comparator Hysteresis Bits. Hysteresis disabled. 10 mV hysteresis enabled. 25 mV hysteresis. 35 mV hysteresis. 50 mV hysteresis. 60 mV hysteresis. 75 mV hysteresis. 85 mV hysteresis. 100 mV hysteresis. 110 mV hysteresis. 125 mV hysteresis. 135 mV hysteresis. 150 mV hysteresis.	0x0	R/W

ANALOG COMPARATORS

Table 68. Bit Descriptions for COMPCON3 (Continued)

Bits	Bit Name	Settings	Description	Reset	Access
		10111	160 mV hysteresis.		
		11100	175 mV hysteresis.		
		11101	185 mV hysteresis.		
		11110	200 mV hysteresis.		
		11111	210 mV hysteresis.		

Address: 0x40068A10, Reset: 0x00000000, Name: COMP_IRQSTAT

Table 69. Bit Descriptions for COMP_IRQSTAT

Bits	Bit Name	Description	Reset	Access
[31:4]	RESERVED	Reserved.	0x0	R
3	COMP3	Comparator 3 Interrupt Status. Set when the interrupt source active.	0x0	R
2	COMP2	Comparator 2 Interrupt Status. Set when the interrupt source active.	0x0	R
1	COMP1	Comparator 1 Interrupt Status. Set when the interrupt source active.	0x0	R
0	COMP0	Comparator 0 Interrupt Status. Set when the interrupt source active.	0x0	R

VDACS

DAC FEATURES

The 12-bit DACs convert digital input Code 0 to Code 4095 to an analog output voltage. Each channel can drive ± 2.5 mA current with a maximum 100 pF capacitance load. Setting DACCON, Bit 9 can boost the drive capability of the DAC to 10 mA.

DAC OVERVIEW

The ADuCM410 and ADuCM420 have 12, 12-bit DACs that support two full-scale ranges: 50 mV to 2.5 V and 50 mV to AVDD.

DAC OPERATION

The VDAC converts the digital codes to analog voltages by the following equation:

$$V_{OUT} = \frac{C}{4095} \times V_{FULLSCALE} \quad (11)$$

where:

V_{OUT} is the DAC output.

C is the code written to DACDATx.

$V_{FULLSCALE}$ is the DAC full-scale voltage. $V_{FULLSCALE}$ can be 2.5 V when DACCONx, Bit 5 = 0, or 3.3 V when DACCONx, Bit 5 = 1.

DAC Pin Mux

To use DAC3 and DAC5 to DAC11, the user must set the appropriate GPxCON bits to output the VDAC signal to an external GPIO (see the relationship shown in [Table 70](#)). VDAC0 shares the same pin as AIN4. VDAC2 shares the same pin as AIN7. If a user enables VDAC0 or VDAC2 and selects those channels as ADC inputs, the ADC measures the VDAC output.

Table 70. DAC Pin Multiplex

GPIO	GPxCON, CONx Bit Setting	VDAC Signal
P4.0	01	DAC3
P4.4	01	DAC5
P4.1	01	DAC6
P4.2	01	DAC7
P5.0	10	DAC8
P5.1	10	DAC9
P5.2	10	DAC10
P5.3	10	DAC11

VDACS

DAC TO BIAS COMPARATOR OR TIA

DAC8 to DAC11 can be selected as the bias voltage for the TIA or comparator. In Figure 8, DAC_BUF refers to a VDAC output buffer.

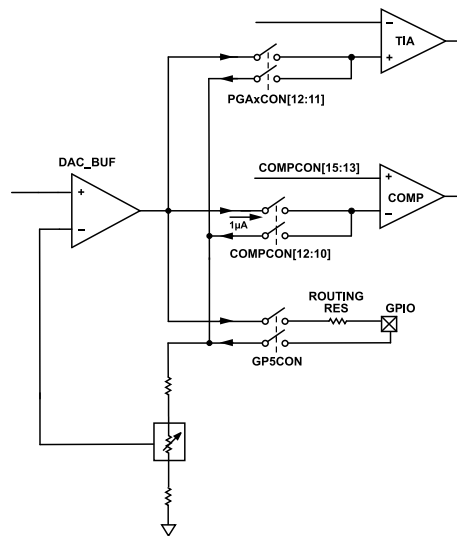

Figure 8. DAC8 to DAC11 Output

Writing to DACDATx Register

The settling time for the voltage DACs is typically 10 μ s.

Writing to a DACDATx register of the DAC channel more frequently than 100 kHz (<10 μ s) may result in an unexpected voltage level on the DAC output pin.

Also, from a digital perspective, do not write user code to the same DACDATx register <1 μ s after a previous write to the same register.

VDAC POWER-UP REQUIREMENTS

The digital logic associated with the VDAC blocks requires the AVDD supply to be fully powered up within 25 ms maximum after the DVDD supply.

If the AVDD supply powers up more than 25 ms after DVDD, there is a risk that the VDAC block does not power up properly and results in incorrect VDAC operation.

If the AVDD supply cannot be powered up within 25 ms of the DVDD supply, it is recommended to follow the ADC power-up and AVDD measurement sequences described in the [ADC Power-Up Requirements](#) section. Then, restart the VDAC by setting the EN bit (DACCONx, Bit 4) and wait for 10 μ s before initializing the VDACS.

The following function demonstrates how to restart the VDAC and set the 10 μ s delay for Channel 0 (repeat for the other channels):

```
void ResetDacBlocks(void)
{
    pADI_VDAC->DACCON0 &=~( BITM_DAC_DACCON_N__EN); // Power down VDAC0
    delay(1uS); // short delay -
    1uS
    pADI_VDAC->DACCON0 |=
        BITM_DAC_DACCON_N__EN; // Enable data writes
    delay(10uS); // short delay - 10uS
}
```

VDACS

REGISTER SUMMARY: DAC

Table 71. DAC Register Summary

Address	Name	Description	Reset	Access
0x40069800 to 0x4006982C (Increments of 0x04)	DACCONx	DAC Control Register	0x00000D02	R/W
0x40069830 to 0x4006985C (Increments of 0x04)	DACDATx	DAC Data Register	0x00000000	R/W

REGISTER DETAILS: DAC

DAC Control Register

Address: 0x40069800 to 0x4006982C (Increments of 0x04), Reset: 0x00000D02, Name: DACCONx

Table 72. Bit Descriptions for DACCONx

Bits	Bit Name	Settings	Description	Reset	Access
[31:10]	RESERVED		Reserved.	0x3	R
9	DRV		Drive Boost Enable. Can drive 10 mA load. 0 Normal Work Mode. 1 Drive Ability Boost Mode. Data sheet minimum and maximum specifications are not applicable when this bit is set.	0x0	R/W
8	PD		DAC Power-Down. 0 DAC Enable. 1 DAC Power Down.	0x1	R/W
[7:6]	RESERVED		Reserved.	0x0	R/W
5	FSLVL		Select Output Full Scale. 0 Full Scale is 2.5 V (VREF). 1 Full Scale is 3.3 V (AVDD). Data sheet minimum and maximum specifications are not applicable when this bit is set.	0x0	R/W
4	EN		DAC Input Data Clear. Set to 1 to enable VDAC writes. 0 DAC Data Clear. 1 DAC Data Normal Input.	0x0	R/W
3:0	RESERVED		Reserved.	0x2	R

DAC Data Register

Address: 0x40069830 to 0x4006985C (Increments of 0x04), Reset: 0x00000000, Name: DACDATx

Table 73. Bit Descriptions for DACDATx

Bits	Bit Name	Settings	Description	Reset	Access
[31:28]	RESERVED		Reserved.	0x0	R
[27:16]	DATAIN		DAC Input Data.	0x0	R/W
[15:0]	Reserved		Reserved.	0x0000	R/W

FLASH CONTROLLER

FLASH CONTROLLER FEATURES

The flash controller provides 1 MB Flash/EE memory in two blocks of 512 kB each (Flash 0 and Flash 1), as well as a 16 kB information space, which contains factory code.

ECC is supported. The single-error correction (SEC) and double error detection (DED) ECC block can detect 1-bit or 2-bit errors during a flash read cycle. Any errors are reported via interrupt sources. ECC is always enabled.

Each flash page is 8 kB in size. Flash accesses are 72 bits wide, with 8 bits dedicated to ECC and the remaining 64 bits for read/write accesses (see Figure 10).

Flash read/write protection is provided with the ability to lock out SWD access to the flash.

24-bit signature functionality is provided for verifying the flash contents. This functionality can be set up to generate a CRC number for the whole of flash or for configurable flash blocks. The hardware automatically stores the 4-byte signature result at the top of the highest address page included in the sign operation.

Two separate internal buses are connected to the flash blocks: one for code access and the other for DMA accesses. The DMA bus has higher priority.

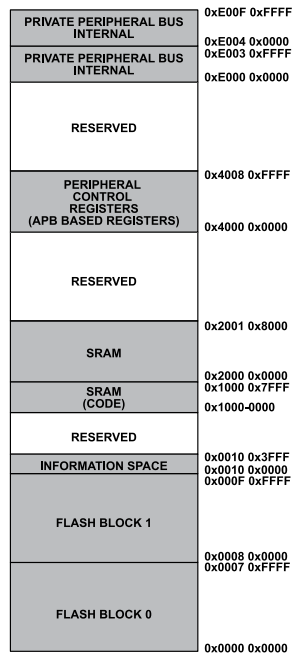

Figure 9. ADuCM410 and ADuCM420 Memory Map (Default)

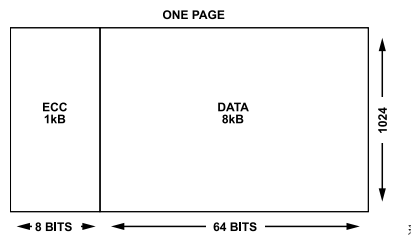

Figure 10. ADuCM410 and ADuCM420 Flash Page Overview

FLASH CONTROLLER

FLASH CONTROLLER OVERVIEW

The flash controller supports read operation on one flash block and erase/write operation on the other block. Peripheral DMA support is also provided for flash keyhole-based writes. A kernel is present in the information space.

The flash controller supports buffered read, executing code from a 64-bit read while fetching the next 64 bits. There is a 32-bit interface for MMR access.

Flash User Space Organization

The user space is the portion of flash memory for user data and program code. Several address ranges in user space are reserved for use as metadata to enable various protection and integrity features.

The top 24 bytes of user space (uppermost page) in each flash block (Flash 0 and Flash 1) are reserved for a signature, user write protection, and the user failure analysis allow key (USERFAAKEYx). See [Figure 11](#) and [Figure 12](#).

Only the signature word is reserved in other user space pages. These other pages can use the most significant word for user space integrity checks on user defined blocks of pages. The signature calculation only seeks the expected signature value from the most significant word of the most significant page targeted for verification.

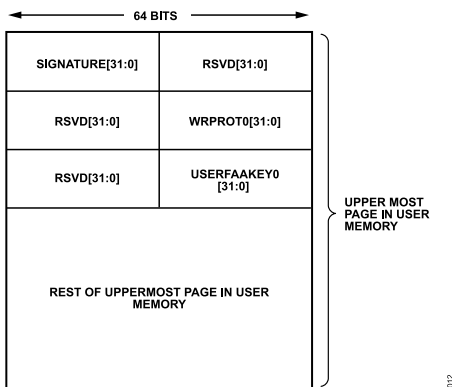

Figure 11. Uppermost Page of User Flash 0

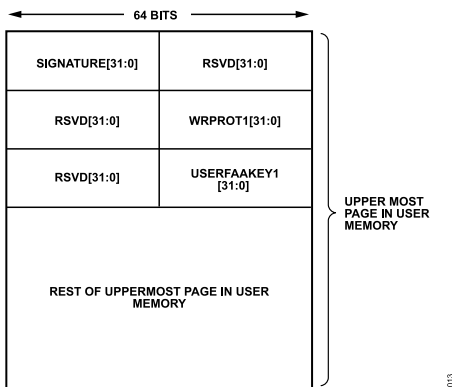

Figure 12. Uppermost Page of User Flash 1

In [Figure 11](#) and [Figure 12](#), the bits are defined as follows:

- ▶ Signature[31:0]: this location holds the expected value for signature verification (integrity check).
- ▶ RSVD[31:0]: reserved for future use.
- ▶ WRPROTx[31:0]: this location holds a bit field representing write protection state for each of the 32 evenly sized groups of pages in the user space.
- ▶ USERFAAKEYx: this location holds the user definable failure analysis key.

FLASH CONTROLLER

Basic Flash Operations

To erase a flash page, complete these steps:

1. Load the user key into the FEEKEY register.
2. Load FEEADR0 with an address from the page that is to be erased.
3. Call the erase page command in the FEECMD register.

The following is an example function:

```
uint32_t FeePErs(uint32_t lAddr)
{
    if(pADI_FLASH->FEESTA&BITM_FLASH_FEESTA_CMDBUSY) return 0;

    pADI_FLASH->FEEKEY = FLASH_USER_KEY;    // (0xF123 F456)
    pADI_FLASH->FEEADR0 = lAddr;
    pADI_FLASH->FEECMD = ENUM_FLASH_FEECMD_CMD_ERASEPAGE;
    return 1;
}
```

To perform basic writes to a flash location, complete these steps. Writes are 64 bits wide.

1. Load the user key into the FEEKEY register.
2. Load FEEFLADR with the address to write to.
3. Load FEEFLDATA1 and FEEFLDATA0 with the 64-bit value to write.
4. Call the write command in the FEECMD register.

The following is an example function:

```
uint32_t FeeWr(uint32_t lAddr, uint64_t udData)
{
    if(pADI_FLASH->FEESTA&BITM_FLASH_FEESTA_CMDBUSY) return 0;

    pADI_FLASH->FEEKEY = FLASH_USER_KEY;
    pADI_FLASH->FEEFLADR = lAddr;
    pADI_FLASH->FEEFLDATA0 = (uint32_t)udData;
    pADI_FLASH->FEEFLDATA1 = udData>>32;
    pADI_FLASH->FEECMD = ENUM_FLASH_FEECMD_CMD_WRITE;
    return 1;
}
```

FLASH PROTECTION AND INTEGRITY

Flash Keys

The user key, 0xF123 F456, is entered via the 32-bit FEEKEY register. This key must be entered to run certain user commands (ERASEPAGE, sign, MASSERASE_ACTIVE, MASSERASE_PASSIVE, and abort) or to write to certain locations at the top of the flash blocks. When entered, the key remains asserted unless a write access to the write protection registers (FEEPRO0, FEEPRO1) or a command is written to the FEECON0 register. When the command starts, the key clears. If this key is entered to enable writes to certain locations in flash, the key must be cleared afterward. To clear the key, write any 32-bit value other than 0xF123 F456 to the key register.

FLASH CONTROLLER

Flash Failure Analysis Key

It may be necessary to perform failure analysis on devices that are returned by a user even though read protection is enabled. A method is provided to allow failure analysis of protected memory by a user flash failure analysis key (USERFAAKEYx).

The user must set the key as two 32-bit values near the top of each user flash block. Supplying this key to Analog Devices allows access to user code for debug purposes.

For Flash 0, the address for the USERFAAKEY0 is 0x7FFE8.

For Flash 1, the address for the USERFAAKEY1 is 0xFFFE8.

Read Protection—Locking/Unlocking Serial Wire Debug (SWD) Port

Clear the JTAGDEBUGEN bit in the flash user setup register to 0 (see FEECON1 in the [User Setup Register](#) section). Clearing this bit locks the serial wire debug port. Debug port writes are ignored. Debug port reads return 0.

User Write Protection

User write protection is provided to prevent accidental writes to pages in user space and to protect blocks of user code when downloading extra code to flash. If a block of data is protected by FEEPROx (FEEPRO0 or FEEPRO1) bits, writes cannot happen to any location in that associated flash block.

0x7FFF0 is the 32-bit location that controls the write protection settings of Flash 0. Similarly, 0xFFFF0 is the 32-bit location that controls the write protection settings of Flash 1. Each bit of 0xFFFF0 protects two flash pages, 16 kB per protection bit. For write protection, memory is split into 32 blocks (512 kB/32 = 16 kB).

The write protection bits are uploaded by the flash controller into local memory mapped registers (FEEPRO0, Bits[31:0] and FEEPRO1, Bits[31:0]) after reset. To write to these memory mapped registers, a user must first write the user key (0xF123 F456) to the key register, FEEKEY. After the write protection is written, it cannot be rewritten without a mass erase of the user space or a page erase of the last page (if the last page is not protected). After an erase, the device must be reset to deassert the uploaded copy of the write protection bits.

The following is the sequence to program the write protection location in flash:

1. Ensure the last page of user space is erased.
2. Write 0xF123 F456, the user key, to the key register (FEEKEY).
3. Write the required write protection directly to flash. Write 0 to enable protection. For example, clearing Bit 27 at Flash Address 0x7FFF0 write protects the 0x60000 to 0x63FFF flash addresses.

```
FeeWr(0x7FFF0, (0xFEFFFFFF) | 0xFFFFFFFF00000000); // Protect flash addresses 0x60000 to 0x63FFF
```

4. Verify that the write completed by polling the status register or enabling a command complete interrupt.
5. Reset the device, and the write protection is uploaded from the user space and activated by the flash controller.

If the write protection in flash has not been programmed, that is 0xFFFF FFFF is uploaded from flash on power-up, the FEEPRO0 and FEEPRO 1 registers can be written to directly from the APB interface to allow a user to verify the write protection before committing it to flash.

The LSB of write protection word corresponds to the lowest addressable block in the flash (Flash 0 or Flash 1). The MSB of the write protection word corresponds to the top addressable block in flash (Flash 0 or Flash 1). Therefore, if the write protection in flash has been programmed, the MSB of the write protection must be programmed to 0 to prevent erasing of the top block, which has the write protection word.

If an attempt is made to write to the FEEPROx word in flash without setting the user key first, an appropriate flag in CMDFAIL is set.

FLASH CONTROLLER

Signature and ECC

The signature is used to check the integrity of the flash device. The flash signature is calculated only on the 64-bit data and not the 64-bit data + 8-bit ECC. The signature is split into two 32-bit values. The sequence for CRC calculations is the first lower 32 bits, and then the next higher 32 bits of the 64-bit flash data with increasing flash address. The 32 bit data is pushed into the CRC polynomial until the specified end address and the result in the CRC is the remainder.

ECC is checked on each 72-bit flash read. If errors are corrected by ECC, the appropriate status flag is set in FEESTA (see the [Status Register](#) section) after the signature check is completed. If errors are detected and cannot be corrected by ECC, the appropriate flag in FEESTA again is set after the signature check is completed. A signature check is treated as a failure when the computed signature is not equal to the stored signature. Software can call a signature check command occasionally or whenever a new block of code is about to be executed. The signature is a 24-bit CRC with the following polynomial $x^{24} + x^{23} + x^6 + x^5 + x + 1$.

The sign command can be used to generate a signature and check the signature of a block of code, where a block can be a single page or multiple pages. A 24-bit linear feedback shift register (LFSR) is used to generate the signature. The hardware assumes that the signature for a block is stored in the upper four bytes of the most significant page of a block. Therefore, these four bytes are not included when generating the signature. Use the following procedure to generate a signature:

1. Write the start address of the block to the FEECCADDR0 register.
2. Write the end address of the block to the FEECCADDR1 register. Make sure the address does not cross from Flash 0 to Flash 1.
3. Write the sign command to the command register.
4. When the command is completes, the signature is available in the signature register. The signature is compared with the data stored in the upper four bytes of the uppermost page of the block. If the data does not match the signature, a fail status is returned in the status register.

While the signature is being computed for a particular flash, all other accesses to the same flash are stalled.

The FEEADDRx addresses are byte addresses but only pages need to be identified. That is, the lower 10 bits are ignored by the hardware.

After a POR, the controller calculates the signature for the kernel in the information space of Flash 0. During this signature calculation, if there is an ECC error corrected and computed signature is the same as the value stored in flash, the signature check is considered a pass and the controller continues its operation normally. During this signature calculation, if there is an ECC 2-bit error detected and the computed signature is the same as the value stored in flash, the signature check is considered a failure and the controller gives a bus error for any instruction code request thereafter (see the [Status Register](#) section).

Flash ECC is enabled by default. It is recommended to keep flash ECC enabled for normal operation although special keys are available to disable the flash ECC feature.

Integrity Check of Internal Flash Page 0 by the On-Chip Kernel

Flash Page 0 is in the address range of 0x00000 to 0x01FFF. Users must reserve the top 32 bits of this page for a Page 0 checksum at Address 0x01FFC.

After every reset, the kernel program checks the value stored at Address 0x01FFC. If the value is 0xFFFFFFFF (no checksum present), the kernel does not run the signature command for Page 0.

If the kernel reads a value not equal to 0xFFFFFFFF at Address 0x01FFC, the kernel assumes that a user generated checksum has been calculated for Page 0 and placed at 0x01FFC. The kernel then runs a signature for Address 0x00000 to Address 0x01FFB and compares the result to the value stored at 0x01FFC. If the kernel signature result matches the value stored at 0x01FFC, the kernel assumes the Page 0 contents are valid and transfers code execution to user code. But, if the kernels signature does not match the value stored at Address 0x01FFC, the kernel does not switch to user code and enters download mode instead.

When developing code, ensure Flash Address 0x01FFC = 0xFFFFFFFF. Analog Devices example projects show how to set this up for IAR Embedded Workbench® via a default linker file and in Keil® µVision®5 via a scatter file. Each program assigns Address 0x01FFC as a dedicated checksum location with 0xFFFFFFFF as the default value.

The kernel only runs a signature on Page 0. The reason is the time duration is too long to complete a signature command on a larger flash area.

FLASH CONTROLLER

It is recommended that user code periodically generate a signature for all its flash memory space. Place the function calling the signature for all of user flash in Page 0. The sign command can run on one or more pages and automatically compares the computed checksum with the checksum written at an offset of 0x1FFC of the last page included in the signature calculation.

This offset allows the Page 0 check after any reset to detect an error in the entire flash area, not just Page 0.

FLASH CONTROLLER PERFORMANCE AND COMMAND DURATION

All flash functions are slower than the CPU execution speed. Apart from flash reads, all other flash operations are significantly slower, as detailed in [Table 74](#).

Table 74. Typical Flash Execution Times

Operation	Typical Time	Comments
Write 72-Bit Location	46 μ s	Flash clock assumed to be 16 MHz
Fast Write	20 μ s	Sequential writes within single flash page, using the WRALCOMP bit in the FEESTA register to trigger writes to the FEEFLDATAx registers.
Mass Erase One Flash Block	11 ms	
Page Erase One Page	11 ms	
Sign Flash 0/Flash 1 User Space	8.192 ms	128k cycles, 512 kB, and flash clock of 16 MHz

In general, use the timings in [Table 74](#) as a guideline only. Software must use the flash status information or the interrupt system to detect when flash operations are complete. If one of the operations in [Table 74](#) executes in the same block as the block from which the CPU fetches instructions, the CPU stalls until the operation is complete.

FLASH ERASE/PROGRAM REQUIREMENTS

Do not program the same flash address more than one time between erase operations.

Do not program the same bit location to 0 more than one time between erase operations.

Violating these guidelines may result in a weakened flash cell that may not retain its correct value for the data sheet defined minimum period.

FLASH BLOCK SWITCHING

For MDIO applications, the system memory is separated into two flash blocks, as shown in [Figure 13](#). See [Table 75](#) for the key definitions.

Table 75. Definition of Keys

Key ^{1,2}	Description
K1B0	Key 1 in Flash 0 at 0x7FFC0
K1B1	Key 1 in Flash 1 at 0xFFFC0
K2B0	Key 2 in Flash 0 at 0x7FFC8
K2B1	Key 2 in Flash 1 at 0xFFFC8
Key 1	Key used to identify latest revision in active flash block at 0x7FFC0
Key 2	Key used for trial runs in active flash block at 0x7FFC8
Key 1'	Key 1 for the other flash block at 0xFFFC0
Key 2'	Key 2 for the other flash block at 0xFFFC8
0xFFs	0xFFFFFFFFFFFFFFFF

¹ Key 1, Key 2, Key 1', and Key 2' refer to the keys as seen by the user.

² K1B0, K1B1, K2B0, and K2B1 refer to the keys as seen by the kernel before block switching occurs.

FLASH CONTROLLER

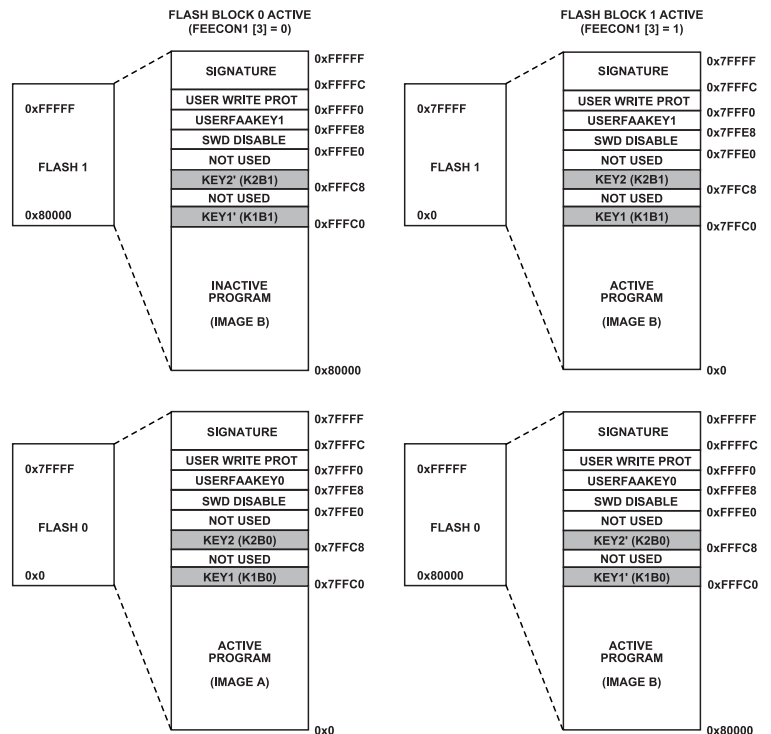

Figure 13. Memory Map for MDIO Flash Swapping

Flash Block Partitioning

In the MDIO dual program image configuration, there are two types of modes: unswitched mode and switched mode. In unswitched mode, Flash 0 is mapped from 0 to 0x7FFFF, and Flash 1 is mapped from 0x80000 to 0xFFFFF. In switched mode, Flash 1 is mapped from 0 to 0x7FFFF, and Flash 0 is mapped from 0x80000 to 0xFFFFF. The user only needs to build code to run in the 0 to 0x7FFFF address range and only run code in this range. A mechanism is provided in the kernel to run from the appropriate flash block after any reset, which is described in the subsequent subsections of the [MDIO](#) section.

For additional information, see [Figure 14](#), [Table 76](#), and [Table 75](#).

Program Image

The choice of which blocks are used is determined by the kernel and based on keys placed at the top of the two 512 kB program image blocks. The six modes of operation are as follows:

- ▶ Debug mode
- ▶ Downloader mode (no valid code)
- ▶ Normal code execution from Program Image A (Flash 0)
- ▶ Trial run from Program Image A (Flash 0)
- ▶ Normal code execution from Program Image B (Flash 1)
- ▶ Trial run from Program Image B (Flash 1)

Each of these modes can only be entered via a reset. Every reset causes the kernel to run, and the kernel chooses the appropriate mode according to keys in the program images.

Each program image contains two keys (see [Table 75](#) for key definitions). For the active program image, Key 1 at Address 0x7FFC0 has a numeric value that indicates the update number. A higher Key 1 value means a more recent update. Key 2 at Address 0x7FFC8 manages the trial runs. A value of 0xFFFFFFFF (erased) indicates a new download. A trial run that has passed must be indicated by changing the value to 0.

Key 1' of the other program image is at 0x7FFC0, and Key 2' of the other program image is at 0x7FFC8.

FLASH CONTROLLER

The user program space CRCs can be stored at 0x7FFFC for Flash 0 and at 0xFFFFC for Flash 1. The CRC is not required as part of the block selection mechanism, but to increase robustness, it is recommended to include it. The user code can check this CRC periodically.

Note that the keys are placed just below the 512 kB boundary, which is assumed to be the top of the program space. There is no restriction against placing code above or below this boundary.

Debug Mode

If after a reset the kernel determines that the download pin function (P2.3) is high, the kernel enters user code regardless of the keys. This debug mode is intended for debugging only.

Choosing the Active Block

After any reset, the kernel chooses the active program image. [Figure 14](#) is the flowchart for choosing the active program image.

Initially, the kernel assumes that the program image with the larger Key 1 is made active. If the associated Key 2 is not 0, this code has not passed the trial run and must not yet be used. Instead, the kernel investigates using the other program image. If Key 2' of the other program image is 0, that program image is chosen. Based on these decisions, the kernel then sets the active program image and exits to the user code. If neither program image has a valid Key 2, the kernel enters its own download mode.

Trial Run Mode

After the user code is entered, the code checks whether to perform a trial run or a normal run. A trial run is indicated if the active Key 1 is less than Key 1'. In a trial run, the old code first checks that the new program image is functioning correctly. The trial run starts in the old program image and performs initial checks, such as CRCs and other checks that the user deems necessary, on the new program image. The trial run can then continue by switching to the new image using Bit 3 (swap) of the FEECON1 register. It is recommended that the code that performs the switching be at a fixed location in Flash Page 0 and be the same in all revisions. Ensure the code following the switching point includes enough identical code so that the CPU pipeline plus the flash look ahead buffers contain the expected code after switching. The user must also clear the memory cache to prevent old code from executing after the switch.

After the new flash blocks are deemed correct, the user code must write 0 to Key 2' of the new flash block to mark the block as correct. The user code can then initiate normal operation. Alternatively, a software reset can be issued, and the device then enters normal mode in the new program image.

A reset may occur during a trial run (for instance, due to power loss) or during a watchdog event (due to program hanging or a deliberate software reset). In this case, a trial run restarts in the old code, and the trial run code then decides how to proceed.

Normal Mode

The user code must check whether to perform a trial run or a normal run. A normal run is indicated if the active Key 1 is larger than the other Key 1. During normal operation, the MDIO master can send download information to the active user code so that new code is written to the other program image. Such a download must also write the new Key 1' with a value of one more than the active Key 1. The new Key 2' must be left erased as 0xFFs (see [Table 75](#)). After the download, the device must be reset to allow a trial run to occur.

Typical Sequence

See [Table 76](#) for a typical sequence and [Table 75](#) for definitions of the keys.

On a new device, the initial code can be downloaded via serial wire if P2.3 is held high and P2.1 is held high during a reset. Otherwise, the kernel enters its own downloader because there is no valid key. At the end of the download to Flash 0, Key 1 is set to 1, and Key 2 is set to 0.

After a reset, normal code is run from Flash 0 because its Key 1 is greater than Key 1' (0xFFs = -1) and its Key 2 is 0. User code can receive MDIO frames instructing it to download code to Flash 1, which results in the new Key 2' being erased and 2 being written to the new Key 1'.

After a reset, the kernel activates Flash 0 for a trial run on the new code because Key 2' of Flash 1 is 0xFFs. If the trial run passes, the user code sets Key 2 to 0 and issues a software reset.

After a reset, the kernel selects Flash 1 because its Key 1 is still larger than Key 1' and the active Key 2 is 0. User code can receive MDIO frames instructing it to download code, which results in Key 2 being erased and 3 being written to Key 1.

FLASH CONTROLLER

The sequence to switch back to Flash 0 is similar to the sequence to switch to Flash 1.

Table 76. Example Block Switching Sequence

No. of Software Downloads ¹	Key 2 of Flash 0	Key 1 of Flash 0	Key 2 of Flash 1	Key 1 of Flash 1	Status	Reset Required
Not applicable	0xFFFFFFFF	0xFFFFFFFF	0xFFFFFFFF	0xFFFFFFFF	Initial startup	Not applicable
1	0	1	0xFFFFFFFF	0xFFFFFFFF	Kernel has downloaded Code 1 to Flash 0	Yes
1	0	1	0xFFFFFFFF	0xFFFFFFFF	Code1 normal execution in Flash 0	No
2	0	1	0xFFFFFFFF	2	Code1 has downloaded Code 2 to Flash 1	Yes
2	0	1	0xFFFFFFFF	2	Code1 starts a trial run on Code 2 in Flash 1	No
2	0	1	0	2	Code 2 trial run complete	Yes
2	0	1	0	2	Code 2 normal execution in Flash 1	No
3	0xFFFFFFFF	3	0	2	Code 2 has downloaded Code 3 to Flash 0	Yes
3	0xFFFFFFFF	3	0	2	Code 2 starts trial run on Code 3 in Flash 0	No
3	0	3	0	2	Code 3 trial mode complete	Yes
3	0	3	0	2	Code 3 normal execution in Flash 0	No
4	0	3	0xFFFFFFFF	4	Code 3 has downloaded Code 4 to Flash 1	Yes
4	0	3	0xFFFFFFFF	4	Code 3 starts a trial run on Code 4 in Flash 1	No
4	0	3	0	4	Code 4 trial mode complete	Yes
4	0	3	0	4	Code4 normal execution in Flash 1	No
...

¹ The ellipsis (...) means the sequence can be infinite.

FLASH CONTROLLER

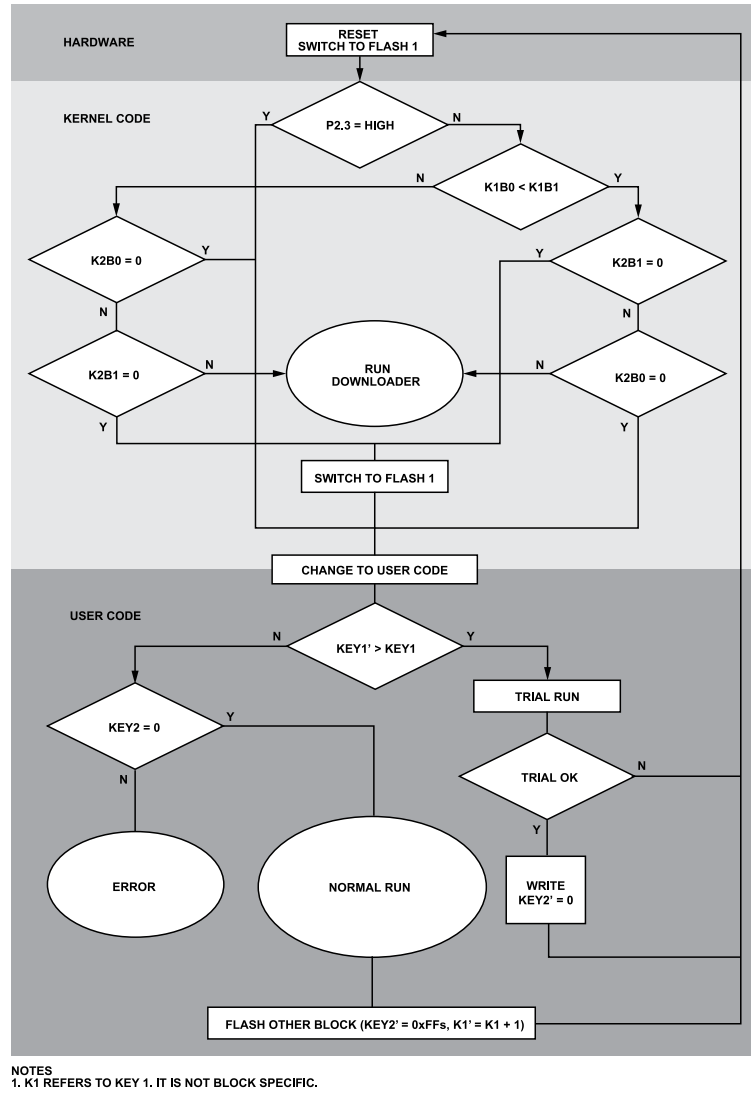

NOTES
1. K1 REFERS TO KEY 1. IT IS NOT BLOCK SPECIFIC.

Figure 14. Flowchart Flash Swapping

REGISTER SUMMARY: FLASH CONTROLLER (FLASH)

Table 77. Flash Register Summary

Address	Name	Description	Reset	Access
0x40048000	FEESTA	Status Register.	0x00000000	R
0x40048004	FEECON0	Command Control Register—Interrupt Enable Register.	0x00000000	R/W
0x40048008	FEECMD	Command Register.	0x00000000	R/W
0x4004800C	FEEFLADR	Flash Address Keyhole Register.	0x00000000	R/W
0x40048010	FEEFLDATA0	Flash Data Register—Keyhole Interface, Lower 32 Bits.	0x00000000	R/W
0x40048014	FEEFLDATA1	Flash Data Register—Keyhole Interface, Upper 32 Bits.	0x00000000	R/W
0x40048018	FEEADR0	Lower Page Address.	0x00000000	R/W
0x4004801C	FEEADR1	Upper Page Address.	0x00000000	R/W
0x40048020	FEEKEY	Flash Key Register.	0x00000000	W
0x40048028	FEEPRO0	Write Protection Register for Flash 0.	0xFFFFFFFF	R/W
0x4004802C	FEEPRO1	Write Protection Register for Flash 1.	0xFFFFFFFF	R/W
0x40048034	FEESIG	Flash Signature.	0x00XXXXXX	R
0x40048038	FEECON1	User Setup Register.	0x00000011	R/W

FLASH CONTROLLER

Table 77. Flash Register Summary (Continued)

Address	Name	Description	Reset	Access
0x40048040	FEWRADDRA	Write Abort Address Register.	0xFFFFFFFF	R
0x40048048	FEEAEN0	Lower 32 Bits of the System IRQ Abort Enable Register.	0x00000000	R/W
0x4004804C	FEEAEN1	Middle 32 Bits of the System IRQ Abort Enable Register.	0x00000000	R/W
0x40048050	FEEAEN2	Upper 32 Bits of the System IRQ Abort Enable Register.	0x00000000	R/W
0x40048064	FEECCONFIG	Flash ECC Configuration Register.	0x00000012	R/W
0x40048074	FEECCADDR0	Flash 0 ECC Error Address via Code Bus.	0x00000000	R
0x40048078	FEECCADDR1	Flash 1 ECC Error Address via Code Bus.	0x00000000	R
0x40048094	FEECCADDR0	Flash 0 ECC Error Address via DMA Bus.	0x00000000	R
0x40048098	FEECCADDR1	Flash 1 ECC Error Address via DMA Bus.	0x00000000	R

REGISTER DETAILS: FLASH CONTROLLER (FLASH)

Status Register

Address: 0x40048000, Reset: 0x00000000, Name: FEESTA

Program flash and Flash 0 are synonymous in this user guide. Either name is used. Similarly, data flash and Flash 1 are the same.

Table 78. Bit Descriptions for FEESTA

Bits	Bit Name	Settings	Description	Reset	Access
31	Reserved.		Reserved.	0x0	R
[30:29]	ECCERRCNTD1		ECC Error Count via DMA Bus of Flash 1. Counts the number of extra 1-bit ECC errors that occur between first ECC error and the ECC error interrupt service routine. 2-bit errors have no effect on this count. 00 No error. 01 1 extra 1-bit ECC error occurred after initial DMA bus ECC error to Flash 1. 10 2 extra 1-bit ECC errors occurred after initial DMA bus ECC error to Flash 1. 11 3 extra 1-bit ECC errors occurred after initial DMA bus ECC error to Flash 1.	0x0	R
[28:27]	ECCHRESPDMA		ECC Error Response on DMA Bus. These bits are set if ECC errors occur during an AHB read of a location on the data code (DCODE) bus. 00 No error. Completed read from program flash via AHB. 01 During AHB read to flash, 2-bit error detected, not corrected. 10 1-bit error is corrected for one flash location while doing AHB read to program flash. 11 Reserved.	0x0	RC
[26:25]	ECCHRESPCODE		ECC Error Response on Code Bus. These bits are set if ECC errors occur during an AHB read of a location on code bus. 00 No error. Completed read from program flash via AHB. 01 During AHB read to flash, 2-bit error detected, not corrected. 10 1-bit error is corrected for one flash location while doing AHB read to program flash. 11 Reserved.	0x0	RC
[24:22]	ECCERRCNTC1		ECC Error Count via Code Bus of Flash 1. This is a 3-bit counter in the flash controller, which counts the number of ECC 1-bit errors detected during data flash reads via AHB. It does not count if an ECC 2-bit error is detected. The counter is cleared when the status register is read by the user. This is useful in the following scenario: if an interrupt is enabled for 1-bit errors, an interrupt is generated by the flash controller on the first 1-bit error detection or correction. This counter shows the number of further 1-bit error corrections that happened between the interrupt generation and the interrupt service. On reaching the maximum count, the counter stays at 0b111. This value is cleared when the status register is read.	0x0	RC
[21:20]	ECCERRCNTD0		ECC Error Count via DMA Bus of Flash 0. Counts the number of extra 1-bit ECC errors that occur between the first ECC error and the ECC error interrupt service routine. 2-bit errors have no effect on this count. 00 No error.	0x0	R

FLASH CONTROLLER

Table 78. Bit Descriptions for FEESTA (Continued)

Bits	Bit Name	Settings	Description	Reset	Access
		01	1 extra 1-bit ECC error occurred after initial DMA bus ECC error to Flash 0.		
		10	2 extra 1-bit ECC errors occurred after initial DMA bus ECC error to Flash 0.		
		11	3 extra 1-bit ECC errors occurred after initial DMA bus ECC error to Flash 0.		
[19:17]	ECCERRCNT0		ECC Error Count via Code Bus of Flash 0. This is a 3-bit counter in the flash controller, which counts the number of ECC 1-bit errors detected during data flash reads via AHB. It does not count if an ECC 2-bit error is detected. The counter is cleared when the status register is read by the user. This is useful in the following scenario: if an interrupt is enabled for 1-bit errors, or an interrupt is generated by the flash controller on the first 1-bit error detection or correction. This counter shows the number of further 1-bit error corrections that happened between the interrupt generation and interrupt service. On reaching the maximum count, the counter stays at 0b111. This value is cleared when the status register is read.	0x0	RC
[16:15]	ECCERRINITSIGN		This value is cleared when the status register is read. 00 No error, completed flash read operation during initial signature check, page signature check. 01 During initial signature check, 2-bit error detected, not corrected for at least one flash location. 10 1-bit error is corrected for one flash location while doing signature commands. 11 During initial signature command, 1-bit error and 2-bit errors are detected on one or more flash locations.	0x0	R
14	Reserved		Reserved	0x0	R
13	SIGNERR		Initial Signature Check Error on Info Space. After reset, the flash controller automatically checks the Info space signature. If the signature check fails, this bit is set to 1. To clear this bit, the correct signature must be programmed to the most significant long word address in the information space.	0x0	R
[12:11]	ECCREADERRFLSH1		ECC Interrupt Errors During AHB Read to Flash 1. 00 No error. Completed read from data flash via AHB bus. 01 1-bit error is corrected for one flash location while doing an AHB read of data flash. 10 During AHB read to Flash 1, 2-bit error detected, not corrected. 11 During AHB read, either ECC error or ECC corrected error detected. This condition can arise if multiple ECC errors in Flash 1 occur before the status register is read.	0x0	RC
[10:9]	ECCREADERRFLSH0		ECC Interrupt Errors During AHB Read to Flash 0. 00 No error. Completed read from program Flash 0 via AHB. 01 During AHB read to Flash 0, 2-bit error detected, not corrected. 10 1-bit error is corrected for one flash location while doing AHB read of Flash 0. 11 During AHB read, indicates either an ECC error or ECC corrected error occurred. This condition can arise if multiple ECC errors in Flash 0 occur before the status register is read.	0x0	RC
[8:7]	ECCERRCMD		ECC Errors Produced During Signature Commands. These bits are set to appropriate values, when a sign command is run. To generate interrupt on these bits, user needs to set the appropriate bit in FEECMD, Bits[4:0]. 00 No error, completed flash read operation during signature check. 01 During signature commands, 2-bit error is detected on one or more flash locations, not corrected. 10 1-bit error is corrected for one or more flash locations while doing signature commands. 11 During signature commands, 1-bit error and 2-bit errors are detected on one or more flash locations.	0x0	RC
6	RESERVED		Reserved.	0x0	R
[5:4]	CMDFAIL		Command Failed. These two bits indicate the status of a command on completion. If multiple commands are executed without a read of the status register, the first error encountered is stored. These bits clear to 00 when read.	0x0	RC

FLASH CONTROLLER

Table 78. Bit Descriptions for FEESTA (Continued)

Bits	Bit Name	Settings	Description	Reset	Access
			00 Completion of a command or a write. 01 Attempted sign check, write or erase of a protected location or out of memory location. the Command is Ignored. If the sign command is executed and the resulting signature does not match the data in the upper four bytes of the upper page in a block, then this is the resulting status. 10 Read verify error. After an erase, the controller reads the corresponding word(s) to verify that the transaction completed. If data read is not all 0xFFs, this is the resulting status. 11 Indicates that a command or a write was aborted by an abort command or a system interrupt has caused an abort.		
3	WRALCOMP		Write Almost Complete—Keyhole Registers Open for Access. This bit can generate an interrupt when IWRALCOMP in the FEECON0 register is set to 1. This bit is set after the first 36 bits of a 72-bit write are completed. For sequential writes within a flash page, this bit can be used to load the next value into the FEEFLDATAx registers, which speeds up programming of a flash page. This bit clears when read.	0x0	RC
2	CMDCOMP		Command Complete. This bit asserts when a command completes and clears when read. If there are multiple commands, this status bit asserts after the first command completes and stays asserted until read.	0x0	RC
1	WRCLOSE		Keyhole Registers Closed for Access. This bit is asserted when the user has written all keyhole registers for a flash write and the controller has started the write. This bit clears only after WRALCOMP flag is set to 1.	0x0	R
0	CMDBUSY		Command Busy. This bit is asserted when the flash block is executing any command entered via the command register.	0x0	R

Command Control Register—Interrupt Enable Register

Address: 0x40048004, Reset: 0x00000000, Name: FEECON0

Table 79. Bit Descriptions for FEECON0

Bits	Bit Name	Settings	Description	Reset	Access
[31:3]	RESERVED		Reserved.	0x0	R
2	IENERR		Command Fail Interrupt Enable. If this bit is set, an interrupt is generated when a command or flash write completes with an error status. 0 Disable. 1 Enable.	0x0	R/W
1	IWRALCOMP		Write Almost Complete Interrupt Enable. Returns 0 when read. Use to speed up write interrupts when programming within a flash page. 0 Disable. 1 Enable.	0x0	R/W
0	IENCMD		Command Complete Interrupt Enable. When set, an interrupt is generated when a command or flash write completes. 0 Disable. 1 Enable.	0x0	R/W

FLASH CONTROLLER

Command Register

Address: 0x40048008, Reset: 0x00000000, Name: FEECMD

Table 80. Bit Descriptions for FEECMD

Bits	Bit Name	Settings	Description	Reset	Access
[31:5]	RESERVED		Reserved.	0x0	R
[4:0]	CMD		Commands. Write command values to this register to begin a specific operation.	0x0	R/W
		00000	Idle. No command executed. Does not need a key.		
		00001	ERASEPAGE. Write the address of the page to be erased to the PAGEADDR0 bits, then write this code to the CMD bits and the flash erases the page. When the erase has completed, the flash reads every location in the page to verify all words in the page are erased. If there is a read verify error, this is indicated in the status register. To erase multiple pages, wait until a previous page erase has completed. Check the status, then issue a command to start the next page erase. Before entering this command, the user key must be written to the key register.		
		00010	Sign. Use this command to generate a signature for a block of data. The signature is generated on a page by page basis. To generate a signature, the address of the first page of the block is entered in the PAGEADDR0 bits, the address of the last page is written to the PageAddr1 register, then write this code to the CMD bits. When the command has completed, the signature is available for reading in the sign register. The last four bytes of the last page in a block is reserved for storing the signature. Before entering this command, user key must be written to the key register. More information on this command is in the Signature and ECC section.		
		00100	Write. This command needs a user key for writing into write protection location and USERFAKEYx location. No key is required for other flash locations. This command takes the address and data from FLADDR and FLDATAx keyhole bits.		
		00101	MASSERASE_ACTIVE. Erase all Flash 0 user space during nonMDIO mode and erase the active flash user space during (depends on the swap bit) in MDIO mode. To enable this operation, the user key must first be written to the key register (this is to prevent accidental erases). When the mass erase has completed, the controller reads every location to verify that all locations are 0xFF FFFF FFFF FFFF. If there is a read verify error, this error is indicated in the status register.		
		00110	MASSERASE_PASSIVE. Erase all Flash 1 user space during nonMDIO mode, and the nonactive flash user block during (depends on the swap bit) in MDIO mode. To enable this operation, the user key must first be written to the key register (this is to prevent accidental erases). When the mass erase has completed, the controller reads every location of the data flash user space to verify that all locations are 0xFF FFFF FFFF FFFF. If there is a read verify error, this error is indicated in the status register. ECC is disabled for this command.		
		00111	Reserved. Do not use.		
		01000	Abort. If this command is issued, then any command currently in progress is stopped. The status indicates the command is completed. Note that this is the only command that can be issued while another command is already in progress. This command can also be used to stop a write that may be in progress. If a write or erase is aborted, the flash timing is violated, and it is not possible to determine if the write or erase completed. To enable this operation, the user key must first be written to the key register (this is to prevent accidental aborts).		
		01111 to 11111	All other values are reserved.		

Flash Address Keyhole Register

Address: 0x4004800C, Reset: 0x00000000, Name: FEEFLADR

Table 81. Bit Descriptions for FEEFLADR

Bits	Bit Name	Settings	Description	Reset	Access
[31:21]	RESERVED		Reserved.	0x0	R
[20:3]	FLADDR		Memory Mapped Address for the Flash Location. Used to specify flash address for write command. The least significant three bits always reads zero. The maximum byte address for the whole flash memory map is 0x10 3FFF.	0x0	R/W
[2:0]	RESERVED		Reserved.	0x0	R

FLASH CONTROLLER

Flash Data Register—Keyhole Interface, Lower 32 Bits

Address: 0x40048010, Reset: 0x00000000, Name: FEEFLDATA0

Table 82. Bit Descriptions for FEEFLDATA0

Bits	Bit Name	Settings	Description	Reset	Access
[31:0]	FLDATA0		Lower 32 Bits of 64-Bit Data to Be Written to Flash. Upper address bits of the page address.	0x0	R/W

Flash Data Register—Keyhole Interface, Upper 32 Bits

Address: 0x40048014, Reset: 0x00000000, Name: FEEFLDATA1

Table 83. Bit Descriptions for FEEFLDATA1

Bits	Bit Name	Settings	Description	Reset	Access
[31:0]	FLDATA1		Upper 32 Bits of 64-Bit Data to Be Written to Flash. If DMA is enabled, then this register acts as a FIFO. A write to this register pushes the old data to the lower 32 bits of 64-bit data (FLDATA0) and current data is written to the upper 32 bits. When the FIFO is full, this register is written twice, and flash write command is automatically triggered.	0x0	R/W

Lower Page Address Register

Address: 0x40048018, Reset: 0x00000000, Name: FEEADR0

This register is a byte addressable register for the whole flash address map. This register is used by the signature and the page erase commands for the page address. Flash page size is 8 kB. The least significant 13 bits are ignored for calculating the start address.

Table 84. Bit Descriptions for FEEADR0

Bits	Bit Name	Settings	Description	Reset	Access
[31:21]	RESERVED		Reserved.	0x0	R
[20:13]	PAGEADDR0		Page Address 0. Used by signature check and erase commands for specifying page address. The Flash 1 user space address map starts at 0x80000, which does not change irrespective of the Flash 0 user space.	0x0	R/W
[12:0]	RESERVED		Reserved.	0x0	R

Upper Page Address Register

Address: 0x4004801C, Reset: 0x00000000, Name: FEEADR1

This register is byte addressable register for the whole flash address map. This register is used by the signature and check blank commands for specifying the page address. The Flash 0 and Flash 1 user page size is 8 kB. The least significant 13 bits are ignored for calculating the end address.

Table 85. Bit Descriptions for FEEADR1

Bits	Bit Name	Settings	Description	Reset	Access
[31:21]	RESERVED		Reserved.	0x0	R
[20:13]	PAGEADDR1		Page Address 1. Used by signature check, blank check, erase commands for specifying page address. Upper address bits of the page address. The Flash 1 address map starts at 0x80000. This does not change irrespective of the Flash 0 user space.	0x0	R/W
[12:0]	RESERVED		Reserved.	0x0	R

Flash Key Register

Address: 0x40048020, Reset: 0x00000000, Name: FEEKEY

Table 86. Bit Descriptions for FEEKEY

Bits	Bit Name	Settings	Description	Reset	Access
[31:0]	KEY		Key Register. The user key is 0xF123 F456.	0x0	W

FLASH CONTROLLER

Write Protection Register for Flash 0

Address: 0x40048028, Reset: 0xFFFFFFFF, Name: FEEP00

User key is required to write to this register.

Table 87. Bit Descriptions for FEEP00

Bits	Bit Name	Settings	Description	Reset	Access
[31:0]	WRPROTO		Write Protection for Flash 0. Write 0 to protect a section of Flash 0. This register is read only if the write protection bits for Flash 0 has been programmed. For more information, see the User Write Protection section.	0xFFFFFFFF	R/W

Write Protection Register for Flash 1

Address: 0x4004802C, Reset: 0xFFFFFFFF, Name: FEEP01

User key is required to write to this register.

Table 88. Bit Descriptions for FEEP01

Bits	Bit Name	Settings	Description	Reset	Access
[31:0]	WRPROT1		Write Protection for Flash 1. Write 0 to protect a section of Flash 1. This register is read only if the write protection bits for Flash 1 has been programmed. For more information, see the User Write Protection section.	0xFFFFFFFF	R/W

Flash Signature Register

Address: 0x40048034, Reset: 0x00XXXXXX, Name: FEESIG

Table 89. Bit Descriptions for FEESIG

Bits	Bit Name	Settings	Description	Reset	Access
[31:24]	RESERVED		Reserved	0x0	R
[23:0]	Sign		Signature	0xXXXXXX	R

User Setup Register

Address: 0x40048038, Reset: 0x00000000, Name: FEECON1

A user key is required to write to this register. After writing to FEECON1, a 32-bit value must be written again to FEEKEY, to reassert the key protection.

Table 90. Bit Descriptions for FEECON1

Bits	Bit Name	Settings	Description	Reset	Access
[31:9]	RESERVED		Reserved.	0x0	R
8	SWAPINFLASHEN		Swap Inside Flash Enable. This bit is only read only. If this bit is set, the user space of each physical flash is logically divided into a top half and a bottom half. Top and bottom image swapping can be enabled.	0x0	R
7	RESERVED		Reserved.	0x0	R/W
6	SWAPFLASH1		Swap Top and Bottom Image Inside Flash 1. This bit is applicable only if SWAPINFLASHEN (Bit 8) is set. If this bit is set, the program code is in the top half of Flash 1. If this bit is cleared, the program code is in the bottom half of Flash 1.	0x0	R/W
5	SWAPFLASH0		Swap Top and Bottom Image Inside Flash 0. This bit is applicable only if SWAPINFLASHEN (Bit 8) is set. If this bit is set, the program code is in the top half of Flash 0. If this bit is cleared, the program code is in the bottom half of Flash 0.	0x0	R/W
4	MDIOMODE		MDIO Mode. This bit is only for read only purposes for the user. If this bit is set, MDIO address swapping can be enabled.	0x0	R
3	SWAPPROGRAMCODE		Swap Program Code for MDIO Mode. This bit is applicable only if MDIOMODE (Bit 4) is set. If this bit is set, the program code is in Flash 1. If this bit is cleared, the program code is in Flash 0. If this bit is 0, the address swap for user space Flash 0 and Flash 1	0x0	R/W

FLASH CONTROLLER

Table 90. Bit Descriptions for FEECON1 (Continued)

Bits	Bit Name	Settings	Description	Reset	Access
			is inactive. And if this bit is 1, the address swap for user space Flash 0 and Flash 1 is active.		
2	AUTOINCREN		Address Auto-Increment for Keyhole Access. If this bit is set, the address specified in the FLADDR bits is auto-incremented and there is no need to write to the FLADDR bits. Address is incremented after the WRALCOMP of the write command or completion of a read command. The incremented address can be read back by reading back FLADDR. FLADDR cannot be written if the AUTOINCREN bit is enabled. This bit needs to be cleared by the user after the intended use is completed. If DMA is enabled (KHDMAEN), this bit is set automatically.	0x0	R/W
1	KHDMAEN		Keyhole DMA Enable. If this bit is 1, then a flash keyhole can be written via DMA. Flash has a separate DMA associated to it.	0x0	R/W
0	JTAGDEBUGEN		JTAG Debug Enable. If this bit is 1, access via the serial wire debug interface is enabled. If this bit is 0, access via the serial wire debug interface is disabled. The kernel sets this bit to 1 when it has finished executing, thus enabling debug access to a user.	0x0	R/W

Write Abort Address Register

Address: 0x40048040, Reset: 0xFFFFFFFF, Name: FEEWRADDRA

Table 91. Bit Descriptions for FEEWRADDRA

Bits	Bit Name	Settings	Description	Reset	Access
[31:0]	WRABORTADDR		Write Abort Address. If a write is aborted, then this register contains the address of the location being written when the write was aborted. This register must be read after the command is aborted. This register must be read before any other command is started. After reset, the value is 0x0, but after initial signature check is completed, this value can be random.	0xFFFFFFFF	R

Lower 32 Bits of the System IRQ Abort Enable Register

Address: 0x40048048, Reset: 0x00000000, Name: FEEAEN0

Table 92. Bit Descriptions for FEEAEN0

Bits	Bit Name	Settings	Description	Reset	Access
[31:0]	SYSIRQABORTEN		Lower 32 Bits of System Interrupt Abort Enable. To allow a system interrupt to abort a write or a command (erase, sign), write a 1 to the appropriate bit in this register.	0x0	R/W

Middle 32 Bits of the System IRQ Abort Enable Register

Address: 0x4004804C, Reset: 0x00000000, Name: FEEAEN1

Table 93. Bit Descriptions for FEEAEN1

Bits	Bit Name	Settings	Description	Reset	Access
[31:0]	SYSIRQABORTEN		Middle 32 Bits of System Interrupt Abort Enable. To allow a system interrupt to abort a write or a command (erase, sign), write a 1 to the appropriate bit in this register.	0x0	R/W

Upper 32 Bits of the System IRQ Abort Enable Register

Address: 0x40048050, Reset: 0x00000000, Name: FEEAEN2

Table 94. Bit Descriptions for FEEAEN2

Bits	Bit Name	Settings	Description	Reset	Access
[31:0]	SYSIRQABORTEN		Upper 32 Bits of System Interrupt Abort Enable. To allow a system interrupt to abort a write or a command (erase, sign), write a 1 to the appropriate bit in this register.	0x0	R/W

FLASH CONTROLLER

Configurable ECC Enable/Disable, Error Response Register

Address: 0x40048064, Reset: 0x00000012, Name: FEECCONFIG

FEEKEY needs to be written to before accessing this register. FEEKEY = 0x5ECCACCE.

Table 95. Bit Descriptions for FEECCONFIG

Bits	Bit Name	Settings	Description	Reset	Access
[31:7]	RESERVED		Reserved.	0x0	R
[6:5]	ECCADDRCON	0 ECC Error Address Register Cannot Be Cleared Until Reset. Current ECC error address is returned directly when reading FEECCADDRx MMRs. 1 ECC Error Address Register Cannot Be Cleared Until Reset. ECC error address is latched on read of FEESTA MMR and is returned when reading FEECCADDRx MMRs. 10 to 11 Previous ECC Error Address Register is Cleared on Read of FEESTA MMR. ECC error address is latched on read of FEESTA MMR and is returned when reading FEECCADDRx MMRs.	0x0	R/W	
[4:3]	ECCINTRERROR	00 Interrupt is Not Generated Even If There is an ECC Error While Reading from Flash via AHB. This applies to both flash. 01 Interrupt is Generated Only If 2-Bit Error is Detected During AHB Read to Flash 0 or Flash 1. 10 Interrupt is Generated Only If 1-Bit Error Corrected During AHB Read to Flash 0 or Flash 1. 11 Interrupt is Generated If Either 2-Bit Detected or 1-Bit Error Corrected During AHB Read to Flash 0 or Flash 1.	0x2	R/W	
[2:1]	ECCAHBERROR	00 AHB Error is not Generated Even If There is an ECC Error While Reading from Flash via AHB. This applies to both flash. 01 AHB Error is Generated Only If 2-Bit Error is Detected During AHB Read to Flash 0 or Flash 1. 10 AHB Error is Generated Only If 1-Bit Error Corrected During AHB Read to Flash 0 or Flash 1. 11 AHB Error is Generated If Either 2-Bit Detected or 1 Bit Error Corrected During AHB Read to Flash 0 or Flash 1.	0x1	R/W	
0	ECCDISABLE		ECC Disable Bit. ECC module can be disabled by setting a bit. When ECC is disabled, ECC module is bypassed, no error correction or error detection is on the data, and raw data from flash location (64-bit + 8-bit ECC) is available.	0x0	R/W

Flash 0 ECC Error Address Via Code Bus Register

Address: 0x40048074, Reset: 0x00000000, Name: FEECCADDR0

Table 96. Bit Descriptions for FEECCADDR0

Bits	Bit Name	Settings	Description	Reset	Access
[31:21]	RESERVED		Reserved.	0x0	R
[20:0]	FLECCADDR0		Flash 0 Address for Which ECC Error is Detected via Code Bus.	0x0	R

Flash 1 ECC Error Address Via Code Bus Register

Address: 0x40048078, Reset: 0x00000000, Name: FEECCADDR1

Table 97. Bit Descriptions for FEECCADDR1

Bits	Bit Name	Settings	Description	Reset	Access
[31:21]	RESERVED		Reserved.	0x0	R
[20:0]	FLECCADDR1		Flash 1 Address for Which ECC Error is Detected via Code Bus.	0x0	R

FLASH CONTROLLER

Flash 0 ECC Error Address Via DMA Bus Register

Address: 0x40048094, Reset: 0x00000000, Name: FEECCADDRD0

Table 98. Bit Descriptions for FEECCADDRD0

Bits	Bit Name	Settings	Description	Reset	Access
[31:21]	RESERVED		Reserved.	0x0	R
[20:0]	FLECCADDRD0		Flash 0 Address for Which ECC Error is Detected via DMA Bus.	0x0	R

Flash 1 ECC Error Address Via DMA Bus Register

Address: 0x40048098, Reset: 0x00000000, Name: FEECCADDRD1

Table 99. Bit Descriptions for FEECCADDRD1

Bits	Bit Name	Settings	Description	Reset	Access
[31:21]	RESERVED		Reserved.	0x0	R
[20:0]	FLECCADDRD1		Flash 1 Address for Which ECC Error is Detected via DMA Bus.	0x0	R

STATIC RANDOM ACCESS MEMORY (SRAM)

This section provides an overview of the SRAM functionality of the ADuCM410 and ADuCM420 processor.

SRAM FEATURES

The SRAM used by the ADuCM410 and ADuCM420 processor supports the following features:

- ▶ Low power controller for data SRAM, instruction SRAM, and cache SRAM.
- ▶ Total available memory: 128 kB.
- ▶ Configurable code, system, and cache SRAM space partitions.
- ▶ SRAM controller consists of four SRAM banks, SRAM0 (32 kB), SRAM1 (32 kB), SRAM2 (64 kB), and SRAM cache (8 kB).
- ▶ When the cache controller is not enabled, the 8 kB SRAM can optionally be used as system SRAM.
- ▶ SECDED is available on all SRAM memories.
- ▶ Read, modify, and write for byte and half-word accesses are supported.

		SRAM DETAILS			
ADDR		MODE 0 8kB CACHE SRAMCON[1:0] = 0bX0 CACHESETUP[0] = 0b1	MODE 1 CACHE OFF SRAMCON[1:0] = 0bX0 CACHESETUP[0] = 0b0	MODE 2 8kB CACHE SRAMCON[1:0] = 0bX1 CACHESETUP[0] = 0b1	MODE 3 CACHE OFF SRAMCON[1:0] = 0bX1 CACHESETUP[0] = 0b0
BANK 0	0x1000_0000	32kB ISRAM	32kB ISRAM		
	0x1000_7FFF				
	0x1000_9FFF				
BANK 1	0x2000_0000	32kB DSRAM	32kB DSRAM	32kB DSRAM	32kB DSRAM
	0x2000_7FFF				
BANK 2	0x2000_8000	64kB DSRAM	64kB DSRAM	64kB DSRAM	64kB dSRAM
	0x2001_7FFF				
BANK 3	0x2001_8000			32kB DSRAM	32kB DSRAM
	0x2001_FFFF				
	0x2002_1FFF			8kB DSRAM	

NOT MAPPED
 CAN USE OR NOT USE AS SRAM THROUGH SRAMCON[1] WHEN CACHE SETUP[0] IS 0

Figure 15. ADuCM410 and ADuCM420 SRAM Memory Details

SRAM CONFIGURATION: INSTRUCTION SRAM VS. DATA SRAM

By default, Bank 0 can optionally be configured as instruction SRAM (ISRAM) or data SRAM (DSRAM). Bank 1 and Bank 2 only support DSRAM. 32 kB of SRAM is mapped at Start Address 0x1000 0000 as Instruction SRAM (see Mode 0 in Figure 15). 32 kB and 64 kB of DSRAM are mapped in two sections: the first starting address is 0x2000 0000 (Bank 1) and the second starting address is 0x2000 8000 (Bank 2). If cache memory is not used, the cache memory can be optionally used by SRAM as seen in Mode 1 in the memory map.

If REMAP = 1 in the SRAMCON register and cache memory is enabled, the 32 kB of SRAM is mapped at Start Address 0x2001 8000 as DSRAM (see Mode 2 in Figure 15). If cache memory is disabled, the cache memory can be used by SRAM as seen in Mode 3 in the memory map.

Default configuration of SRAM at power-up and hardware reset, the 32 kB of SRAM is made available as ISRAM. If the user needs to exercise the option of using additional 8 kB of SRAM, the CCEN bit in the cache setup register must be set to 0 at the start of the user code. The registers listed in Table 100 require unlock keys to be configured.

When the cache controller is enabled, the SRAM bank associated with the cache is not accessible outside of the cache feature. A bus error (unmapped address) is generated if access is attempted.

ECC PROTECTION

The purpose of the ECC error interrupts is to notify that information in the SRAM has been lost and to prevent further actions that may otherwise be corrupted by memory errors. ECC for SRAM is always enabled. Analog Devices strongly recommends that ECC always be turned on. The ECC disable feature may only be useful for debugging purposes.

The SRAM controller uses a Hsiao algorithm, which protects every data bit by a unique combination of parity bits. When SRAM detects ECC errors in an access on any interface, the details of the erroneous access can be seen in the following registers: SRAMECCSTA, SRAMECCAx,

STATIC RANDOM ACCESS MEMORY (SRAM)

SRAMECCD_x, and SRAMECCP_x, where x is 0 to 2. An interrupt is signaled on the corresponding interrupt ports. By default, ECC is enabled across three SRAM blocks, which can be seen on SRAMECCCON, Bits[2:0]. SRAMECCCON, Bits[6:5] are used to control the error type reported by interrupt. SRAMECCCON, Bits[8:7] are used to select the stored or current error information. The following error information cannot be captured until its error status is cleared. Latched error information comes from current error information and is stored when reading the SRAMECCSTA register.

INITIALIZATION IN CACHE AND INSTRUCTION SRAM

When cache memory is used, parity can also be enabled on its associated SRAM bank (Bank 3). In this case (when SRAM Bank 3 is used as cache memory), initialization is not required because initialization is only required when the user performs byte or half-word accesses to the SRAM with parity check enabled. When SRAM Bank 3 is used as cache memory, all the accesses are word accesses. To prevent undesired bus errors, the controller ignores any initialization of SRAM Bank 3 when the cache is enabled.

As with the cache memory, the SRAM banks used as instruction memory do not require any previous initialization when ECC checks are enabled. If triggered on ISRAM, initialization is completed. If the ISRAM was initialized and an access to it was received, the access is halted until initialization is completed.

REGISTER SUMMARY: SRAM CONTROLLER (SRAM)

Table 100. ISRAM Register Summary

Address	Name	Description	Reset	Access
0x40065000	SRAMCON	SRAM Control Register.	0x00000000	R/W
0x4006500C	SRAMECCCON	SRAM ECC Control Register.	0x000000CF	R/W
0x40065010	SRAMECCSTA	SRAM ECC Status Register.	0x00000000	R
0x40065014	SRAMECCA0	SRAM0 ECC Error Address Register.	0x00000000	R
0x40065018	SRAMECCD0	SRAM0 ECC Error Data Register.	0x00000000	R
0x4006501C	SRAMECCP0	SRAM0 ECC Error Parity Register.	0x00000000	R
0x40065020	SRAMECCA1	SRAM1 ECC Error Address Register.	0x00000000	R
0x40065024	SRAMECCD1	SRAM1 ECC Error Data Register.	0x00000000	R
0x40065028	SRAMECCP1	SRAM1 ECC Error Parity Register.	0x00000000	R
0x4006502C	SRAMECCA2	SRAM2 ECC Error Address Register.	0x00000000	R
0x40065030	SRAMECCD2	SRAM2 ECC Error Data Register.	0x00000000	R
0x40065034	SRAMECCP2	SRAM2 ECC Error Parity Register.	0x00000000	R

REGISTER DETAILS: SRAM CONTROLLER (SRAM)

SRAM User Key 0 Register

Address: 0x40002134, Reset: 0x00000000, Name: USERKEY0

Table 101. Bit Descriptions for USERKEY0

Bits	Bit Name	Settings	Description	Reset	Access
[31:0]	KEY		Key register for SRAMCON. Write 0x8D5F9FEC to enable protected registers to be modified or to allow protected commands to be executed.	0x0	R/W

SRAM User Key 1 Register

Address: 0x40002144, Reset: 0x00000000, Name: USERKEY1

Table 102. Bit Descriptions for USERKEY1

Bits	Bit Name	Settings	Description	Reset	Access
[31:0]	KEY1		Key register for SRAMECCCON. Write 0xCDFAA5C8 to enable protected registers to be modified or to allow protected commands to be executed.	0x0	R/W

STATIC RANDOM ACCESS MEMORY (SRAM)**SRAM Control Register**

Address: 0x40065000, Reset: 0x00000002, Name: SRAMCON

SRAMCON register is key protected. SRAM USERKEY0 must be written to first before modifying this register.

Table 103. Bit Descriptions for SRAMCON

Bits	Bit Name	Settings	Description	Reset	Access
[31:2]	RESERVED		Reserved.	0x0	R
1	CSEL		Use Cache as a Part of SRAM0. Key Protected. 0 Cache Not Part of SRAM. Clear for normal Cache operation. 1 Cache Is Part of SRAM.	0x0	R/W
0	REMAP		SRAM0 Selection. Key Protected. 0 SRAM0 as Instruction SRAM (ISRAM). 1 SRAM0 as Data SRAM (DSRAM).	0x0	R/W

SRAM ECC Control Register

Address: 0x4006500C, Reset: 0x000000C7, Name: SRAMECCCON

SRAMECCCON register is key protected. SRAM USERKEY1 must be written to first before modifying this register.

Table 104. Bit Descriptions for SRAMECCCON

Bits	Bit Name	Settings	Description	Reset	Access
[31:9]	RESERVED		Reserved.	0x0	R
[8:7]	RECERRTYPE		ECC Error Address and Data Record Type. 0x0 Return Current Error Address and Data Information. Current ECC error address and data registers cannot be cleared until reset. Current ECC error address is returned on reading SRAMECCA0, SRAMECCA1, and SRAMECCA2. The data value can be read via SRAMECCD0, SRAMECCD1, or SRAMECCD2. 0x1 Return Stored Error Address and Data Information. Current ECC error address and data registers cannot be cleared until reset. The error address is latched when the ECC error status register is read. The latched ECC error address and data are returned on reading the address and data registers. 0x2, 0x3 Return Stored Error Address and Data Information. Current ECC error address and data registers are cleared when the ECC error status register is read. The error address is latched at the same time. The latched ECC error address and data are returned on reading the address and data registers.	0x1	R/W
[6:5]	INTERRTYPE		ECC Interrupt Error Response Type. 0x0 No Error Report. 0x1 2-Bit Error Report. 0x2 1-Bit Error Report. 0x3 1-Bit or 2-Bit Error Report.	0x1	R/W
[4:3]	BUSERRTYPE		ECC AHB Bus Error Response Type. 0x0 No Error Report. 0x1 2-Bit Error Report. 0x2 1-Bit Error Report. 0x3 1-Bit or 2-Bit Error Report.	0x1	R/W
[2:0]	EN		ECC Check Enable. 0x0 Disable All SRAM ECC. 0x1 SRAM0 ECC Enable. 0x2 SRAM1 ECC Enable. 0x3 SRAM2 ECC Enable. 0x4 SRAM0 and SRAM1 ECC Enable. 0x5 SRAM0 and SRAM2 ECC Enable.	0x7	R/W

STATIC RANDOM ACCESS MEMORY (SRAM)**Table 104. Bit Descriptions for SRAMECCON (Continued)**

Bits	Bit Name	Settings	Description	Reset	Access
		0x6	SRAM1 and SRAM2 ECC Enable.		
		0x7	SRAM0, SRAM1, and SRAM2 ECC Enable.		

SRAM ECC Status Register

Address: 0x40065010, Reset: 0x00000000, Name: SRAMECCSTA

Table 105. Bit Descriptions for SRAMECCSTA

Bits	Bit Name	Settings	Description	Reset	Access
[31:11]	RESERVED		Reserved.	0x0	R
[10:8]	ERRCNT		ECC Error Counter.	0x0	R
[7:6]	RESERVED		Reserved.	0x0	R
5	S2ERR1B		Set if there is an SRAM2 ECC 1-Bit Error.	0x0	R
4	S2ERR2B		Set if there is an SRAM2 ECC 2-Bit Error.	0x0	R
3	S1ERR1B		Set if there is an SRAM1 ECC 1-Bit Error.	0x0	R
2	S1ERR2B		Set if there is an SRAM1 ECC 2-Bit Error.	0x0	R
1	S0ERR1B		Set if there is an SRAM0 ECC 1-Bit Error.	0x0	R
0	S0ERR2B		Set if there is an SRAM0 ECC 2-Bits Error.	0x0	R

SRAM0 ECC Error Address Register

Address: 0x40065014, Reset: 0x00000000, Name: SRAMECCA0

Table 106. Bit Descriptions for SRAMECCA0

Bits	Bit Name	Settings	Description	Reset	Access
[31:0]	ADDR		ECC Error Address	0x0	R

SRAM0 ECC Error Data Register

Address: 0x40065018, Reset: 0x00000000, Name: SRAMECCD0

Table 107. Bit Descriptions for SRAMECCD0

Bits	Bit Name	Settings	Description	Reset	Access
[31:0]	DATA		ECC Error Raw Data	0x0	R

SRAM0 ECC Error Parity Register

Address: 0x4006501C, Reset: 0x00000000, Name: SRAMECCP0

Table 108. Bit Descriptions for SRAMECCP0

Bits	Bit Name	Settings	Description	Reset	Access
[31:7]	RESERVED		Reserved.	0x0	R
[6:0]	PARITY		ECC Error Raw Parity.	0x0	R

SRAM1 ECC Error Address Register

Address: 0x40065020, Reset: 0x00000000, Name: SRAMECCA1

Table 109. Bit Descriptions for SRAMECCA1

Bits	Bit Name	Settings	Description	Reset	Access
[31:0]	ADDR		ECC Error Address	0x0	R

STATIC RANDOM ACCESS MEMORY (SRAM)**SRAM1 ECC Error Data Register**

Address: 0x40065024, Reset: 0x00000000, Name: SRAMECCD1

Table 110. Bit Descriptions for SRAMECCD1

Bits	Bit Name	Settings	Description	Reset	Access
[31:0]	DATA		ECC Error Raw Data	0x0	R

SRAM1 ECC Error Parity Register

Address: 0x40065028, Reset: 0x00000000, Name: SRAMECCP1

Table 111. Bit Descriptions for SRAMECCP1

Bits	Bit Name	Settings	Description	Reset	Access
[31:7]	RESERVED		Reserved.	0x0	R
[6:0]	PARITY		ECC Error Raw Parity.	0x0	R

SRAM2 ECC Error Address Register

Address: 0x4006502C, Reset: 0x00000000, Name: SRAMECCA2

Table 112. Bit Descriptions for SRAMECCA2

Bits	Bit Name	Settings	Description	Reset	Access
[31:0]	ADDR		ECC Error Address	0x0	R

SRAM2 ECC Error Data Register

Address: 0x40065030, Reset: 0x00000000, Name: SRAMECCD2

Table 113. Bit Descriptions for SRAMECCD2

Bits	Bit Name	Settings	Description	Reset	Access
[31:0]	DATA		ECC Error Raw Data	0x0	R

SRAM2 ECC Error Parity Register

Address: 0x40065034, Reset: 0x00000000, Name: SRAMECCP2

Table 114. Bit Descriptions for SRAMECCP2

Bits	Bit Name	Settings	Description	Reset	Access
[31:7]	RESERVED		Reserved.	0x0	R
[6:0]	PARITY		ECC Error Raw Parity.	0x0	R

CACHE

Enabling cache memory provides a significant performance increase for applications executing from Flash. Cache memory coexists with SRAM. When cache memory is enabled, part of the SRAM is allocated to cache and thus this cache memory cannot be used for other purposes. Instruction cache is 8 kB.

CACHE PROGRAMMING MODEL

Instruction cache is enabled on power-up.

PROGRAMMING GUIDELINES

The sequence to configure the cache is as follows:

1. Read the CCEN bit in the cache setup register to make sure that cache memory is enabled by default.
2. Write the user key to cache key register.
3. Set the necessary bit configuration for the cache setup register.

REGISTER SUMMARY: CACHE CONTROLLER

Table 115. Cache Register Summary

Address	Name	Description	Reset	Access
0x40044000	STAT	Cache Status Register.	0x00008001	R
0x40044004	SETUP	Cache Setup Register.	0x00008001	R/W
0x40044008	KEY	Cache Key Register.	0x00000000	W
0x40044034	ECCSTAT	Cache SRAM ECC Status Register.	0x00000000	R
0x40044038	ECCADDR	Cache SRAM ECC Address Register.	0x00000000	R

REGISTER DETAILS: CACHE CONTROLLER

Cache Status Register

Address: 0x40044000, Reset: 0x00000000, Name: STAT

Table 116. Bit Descriptions for STAT

Bits	Bit Name	Settings	Description	Reset	Access
[31:2]	RESERVED		Reserved.	0x800	R
1	CCLCK		Code Cache Lock Status. This bit is set when the cache memory is locked, and cleared when cache is unlocked. Reads are looked upon in cache, and reads are not allocated for misses.	0x0	R
0	CCEN		Cache Enable Status. If this bit is set to 1 then cache is enabled. 0 when cache is disabled.	0x1	R

Cache Setup Register

Address: 0x40044004, Reset: 0x00000000, Name: SETUP

A cache user key is required to enable a write to this location. Key is cleared after a write to this register. See the [Cache Key Register](#) section.

Table 117. Bit Descriptions for SETUP

Bits	Bit Name	Settings	Description	Reset	Access
[31:1]	RESERVED		Reserved.	0x0	R
0	CCEN		Cache Enable. 1 Instruction cache is enabled for AHB accesses. 0 Instruction cache is disabled, and all AHB accesses are via flash memory.	0x1	R/W

CACHE

Cache Key Register

Address: 0x40044008, Reset: 0x00000000, Name: KEY

Table 118. Bit Descriptions for KEY

Bits	Bit Name	Settings	Description	Reset	Access
[31:0]	KEY		Cache Key Register. Unlock protected features by writing 0xF123 F456 to this register. Returns 0x0 if read. The key is cleared automatically after writing to the cache setup register.	0x0	W

Cache SRAM ECC Status Register

Address: 0x40044034, Reset: 0x00000000, Name: ECCSTAT

This register is cleared on a read.

Table 119. Bit Descriptions for ECCSTAT

Bits	Bit Name	Settings	Description	Reset	Access
[31:7]	RESERVED		Reserved.	0x0	R
[6:4]	ECCERRORCNT		Cache as SRAM ECC Error Counter.	0x0	R
[3:2]	ECCHRESPSTA		Cache as SRAM ECC Error Instruction Cache Status. 0 No Error. 1 1-Bit Error. 10 2-Bit Error. 11 Reserved.	0x0	R
[1:0]	ECCINTSTA		Cache as SRAM ECC Error Interrupt Status. 0 No Error. 1 1-Bit Error. 10 2-Bit Error. 11 Either 1-Bit Error or 2-Bit Error.	0x0	R

Cache SRAM ECC Address Register

Address: 0x40044038, Reset: 0x00000000, Name: ECCADDR

Table 120. Bit Descriptions for ECCADDR

Bits	Bit Name	Settings	Description	Reset	Access
[31:11]	RESERVED		Reserved.	0x0	R
[10:0]	ECCADDR		Cache as SRAM ECC Error Address.	0x0	R

I²C SERIAL INTERFACES

I²C FEATURES

The ADuCM410 and ADuCM420 contain three independent I²C channels.

The I²C interface features master or slave mode with 2-byte transmit and receive FIFOs. Slave mode supports four slave address/ID registers with independent transmission FIFOs for each of the four slave addresses.

The I²C interface supports 7-bit and 10-bit addressing modes: four 7-bit device addresses, or one 10-bit address and two 7-bit addresses in slave mode, and repeated starts in master and slave modes. Clock stretching can be enabled by other devices on the bus without causing any issues with the ADuCM410 and ADuCM420. Master arbitration, continuous read mode for the master or up to 512 bytes, fixed read, and internal and external loopback are also available.

The I2C0 and I2C2 channels support 3.4 MHz, high-speed mode in slave mode.

Support for DMA in master and slave modes is provided, as well as software control on the slave of the no acknowledge (NACK) signal.

I²C OVERVIEW

The I²C data transfer uses a serial clock signal (SCLx) and a serial data signal (SDAx). These signals are configured in a wire-AND'ed format that allows arbitration in a multimaster system.

The transfer sequence of an I²C system consists of a master device initiating a transfer by generating a start condition while the bus is idle. The master transmits the slave device address and the direction of the data transfer during the initial address transfer. If the master does not lose arbitration and the slave acknowledges the initial address transfer, the data transfer is initiated, which continues until the master issues a stop condition, and the bus becomes idle. [Figure 16](#) shows a typical I²C transfer.

A master device can be configured to generate the serial clock. The frequency is programmed by the user in the serial clock divisor register, DIV. The master channel can be set to operate in fast mode (400 kHz), standard mode (100 kHz), or high speed mode (3.4 MHz).

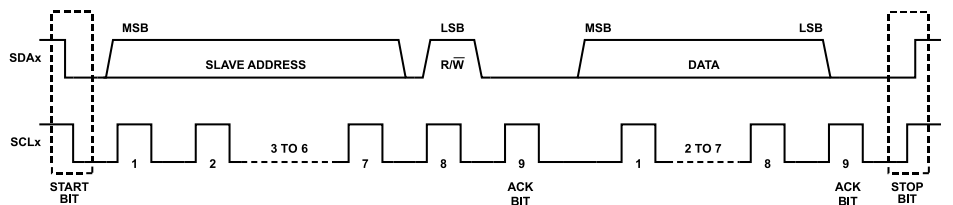

Figure 16. Typical I²C Transfer Sequence

The user programs the I²C bus peripheral address in the I²C bus system. This ID can be modified any time a transfer is not in progress. The user can set up to four slave addresses that are recognized by the peripheral. The peripheral is implemented with a 2-byte FIFO for the receive shift register, and four independent 2-byte FIFOs for the transmit shift register. The IRQ and status bits in the control registers are available to signal to the processor core when the FIFOs need to be serviced.

I²C OPERATION

I²C Startup

The following steps are required to run the I²C peripheral:

1. PCLK1 is the system clock to the I²C blocks. Configure the PCLK1 frequency via CLKCON1, Bits[8:6].
2. Configure the digital pins for I²C operation via the GPxCON register.
3. Configure the I²C registers as required for slave or master operation.
4. Enable the I²C slave or master interrupt source as required.

Note that, when using I²C, the user must disable the internal pull-up resistors on the I²C pins via the GP0PE register.

Table 121. GPIO Multiplex

GPIO	GPxCON (CONx Bit Setting)	I ² C Signal
P0.4	01	SCL0
P0.5	01	SDA0

I²C SERIAL INTERFACES

Table 121. GPIO Multiplex (Continued)

GPIO	GPxCON (CONx Bit Setting)	I ² C Signal
P1.2	01	SCL1
P1.3	01	SDA1
P0.6	01	SCL2
P0.7	01	SDA2

Addressing Modes

7-Bit Addressing

The ID0, ID1, ID2, and ID3 registers contain the slave device IDs. The device compares the four IDx registers to the address byte. To be correctly addressed, the seven MSBs of either ID register must be identical to that of the seven MSBs of the first received address byte. The LSB of the ID registers (the transfer direction bit) is ignored in the process of address recognition.

The master addresses a device using the ADDR0 register.

10-Bit Addressing

This feature is enabled by setting SCTL, Bit 1 for master and slave mode.

The 10-bit address of the slave is stored in the ID0 and ID1 registers, where the ID0 register contains the first byte of the address, and the R/W bit and the upper five bits must be programmed to 11110, as shown in Figure 17. The ID1 register contains the remaining eight bits of the 10-bit address. The ID2 and ID3 registers can still be programmed with 7-bit addresses.

The master communicates to a 10-bit address slave using the ADDR0 and ADDR1 registers. The format is described in Figure 17. To perform a read from a slave with a 10-bit address, the master must first send a 10-bit address with the read/write bit cleared, and then the master must generate a repeated start and send only the first byte of the address with the read/write bit set. A repeated start is generated by writing to the ADDR0 register while the master is still busy.

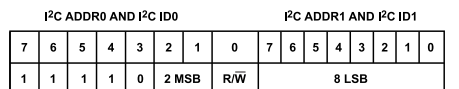

Figure 17. 10-Bit Address Format of I²C ADDR0/ADDR1 Register

A repeated start condition occurs when a second start condition is sent to a slave without a stop condition being sent in between. This sequence allows the master to reverse the direction of the transfer by changing the R/W bit without having to give up control of the bus.

An example of a transfer sequence is shown in Figure 18. This sequence is generally used in cases where the first data sent to the devices sets up the register address to be read from.

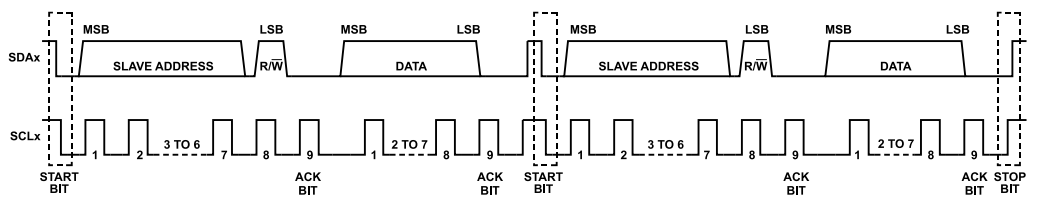

Figure 18. I²C Repeated Start Sequence

On the slave side, an interrupt is generated (if enabled in the SCTL register) when a repeated start and a slave address are received. This sequence can be differentiated from receiving a start and slave address by using the start and REPSTART status bits in the SSTAT MMR.

On the master side, the master generates a repeated start if the ADDR0 register is written while the master is still busy with a transaction. After the state machine has started to transmit the device address, it is safe to write to the ADDR0 register.

I²C SERIAL INTERFACES

For example, if a transaction involving a write, a repeated start, and then a read/write is required, write to the ADDR0 register either after the state machine starts to transmit the device address or after the first MTXREQ interrupt is received. When the transmit FIFO empties, a repeated start is generated.

Similarly, if a transaction involving a read, a repeated start, and then a read/write is required, write to the first master address byte register, ADDR0, either after the state machine starts to transmit the device address or after the first MRXREQ interrupt is received. When the requested receive count is reached, a repeated start is generated.

I²C Clock Control

The I²C master in the system generates the serial clock for a transfer. The master channel can be configured to operate in fast mode (400 kHz) or standard mode (100 kHz) or high speed mode (3.4 MHz).

The bit rate is defined in the DIV MMR as follows:

$$f_{SCL} = f_{PCLK1} / ((Prescale + 1) * (Low + High)) \quad (12)$$

where:

f_{SCL} is the I²C baud rate.

f_{PCLK1} is the PCLK1 frequency.

Prescale is the prescaler for the SCLx clock via TCTL, Bits[11:9].

High is the high period of the clock, via I²C DIV, Bits[15:8] = serial clock high time ÷ PCLK1 period.

Low is the low period of the clock, via I²C DIV, Bits[7:0] = serial clock low time ÷ PCLK1 period.

For 100 kHz SCLx operation with a low time of 5 µs, a high time of 5 µs, and a PCLK1 frequency of 160 MHz, divided by 7 + 1 prescale.

$$High = 5 \mu s / (1/20,000,000) = 100 \quad (13)$$

$$Low = 5 \mu s / (1/20,000,000) = 100 \quad (14)$$

$$f_{SCLx} = 160,000,000 / (7 + 1) / (100 + 100) = 100 \text{ kHz} \quad (15)$$

TCTL, Bits[11:9] = 0x7 and DIV = 0x6464 to achieve a 100 kHz I²C baud rate.

Resetting the I²C Block

Three steps are needed to reset the I²C block.

In master mode,

1. Clear MCTL, Bit 0 to 0 to disable the I²C master.
2. Set SHCTL, Bit 0 to 1, which is a write only register. Writing to this bit resets the start and stop detection circuits of the I²C block and clears the LINEBUSY status bit (MSTAT, Bit 10).
3. Set MCTL, Bit 0 to 1 to reenble the I²C master.

In slave mode,

1. Clear SCTL, Bit 0 to 0 to disable the I²C slave.
2. Set SHCTL, Bit 0 to 1, which is a write only register. Writing to this bit resets the start and stop detection circuits of the I²C block.
3. Set SCTL, Bit 0 to 1 to reenble the I²C slave

Do not reset the I²C peripheral on two consecutive communication sequences.

I²C OPERATING MODES

Master Transfer Initiation

If the master enable bit, MASEN (MCTL, Bit 0) is set, a master transfer sequence is initiated by writing a value to the ADDR0 register. If there is valid data in the MTX register, it is the first byte transferred in the sequence after the address byte during a write sequence.

I²C SERIAL INTERFACES

Slave Transfer Initiation

If the slave enable bit SLVEN (SCTL, Bit 0) is set, a slave transfer sequence is monitored for the device address in Register ID0, Register ID1, Register ID2, or Register ID3. If the device address is recognized, the device participates in the slave transfer sequence.

Note that a slave operation always starts with the assertion of one of three interrupt sources, a read request (MRXREQ/SRXREQ), a write request (MTXREQ, STXREQ), or a general call interrupt (GCINT), and the software must always look for a stop interrupt to ensure that the transaction has completed correctly and to deassert the stop interrupt status bit.

Receive/Transmit Data FIFOs

The transmit data path consists of a master transmit FIFO and four slave transmit FIFOs, the MTX and STX registers (each two bytes deep), and a transmit shifter. The transmit status bits in MSTAT, Bits[1:0] and SSTAT, Bit 0 denote whether there is valid data in the transmit FIFO. Data from the transmit FIFO is loaded into the transmit shifter when a serial byte begins transmission. If the transmit FIFO is not full during an active transfer sequence, the transmit request bit (MSTAT, Bit 2 or SSTAT, Bit 2) asserts. Figure 19 shows the effect of not having the slave transmit FIFO full at the start of a read request from a master. An extra transmit interrupt can be generated after the read bit. This extra transmit interrupt occurs if the transmit FIFO is not full.

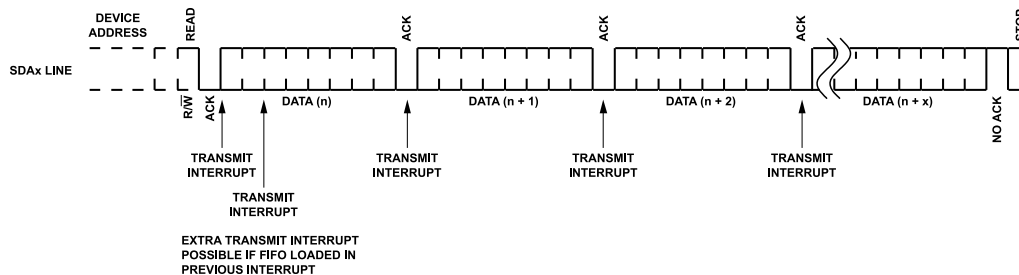

Figure 19. I²C Slave Transmit Interrupt Details

In the slave, if there is no valid data to transmit when the transmit shifter is loaded, the transmit underflow status bit asserts (MSTAT, Bit 12 and SSTAT, Bit 1). In slave mode, the transmit FIFO must be loaded with a byte before the falling edge of SCLx before the acknowledge or no acknowledge is asserted.

If the transmit FIFO is empty on the falling edge of SCLx for a R/W bit, the slave returns a no acknowledge because the slave in this case controls the acknowledge or no acknowledge.

If the first byte is transmitted correctly in a slave transmit sequence, but the transmit FIFO is empty for any subsequent bytes in the same transfer, the slave returns the previous transmitted byte. This operation is due to the master having control of the acknowledge/no acknowledge during a slave transfer sequence.

The master generates a stop condition if there is no data in the transmit FIFO and the master is writing data.

The receive data path consists of a master and slave receive FIFO, MRX and SRX, each two bytes deep. The receive request interrupt bit (MSTAT, Bit 3 or SSTAT, Bit 3) indicates whether there is valid data in the receive FIFO. Data is loaded into the receive FIFO after each byte is received. If valid data in the receive FIFO is overwritten by the receive shifter, the receive overflow status bit is asserted (MSTAT, Bit 9 or I2C_SSTAT, Bit 4).

Automatic Clock Stretching

It is recommended that automatic clock stretching be enabled, especially in slave mode.

A timeout feature is added to ensure that the I²C block never erroneously holds the SCLx pin low indefinitely. A separate status bit for master and slave mode indicates if a stretch timeout occurred.

The ASTRETCHSCL register controls automatic clock stretching. If automatic clock stretching is enabled, the I²C hardware holds the SCLx signal low after the falling edge of SCLx before an acknowledge or no acknowledge during the following conditions:

- ▶ The transmit FIFO is empty when a valid read request is active for the master or slave.
- ▶ If the transmit FIFO is still empty at the end of the timeout period, the following occurs:

I²C SERIAL INTERFACES

- ▶ If the transmit FIFO is empty on the falling edge of SCLx for a R/W bit, the slave returns a no acknowledge after the timeout period.
- ▶ If the first byte is transmitted correctly in a slave transmit sequence, but the transmit FIFO is empty for any subsequent bytes in the same transfer with clock stretch enabled, the slave returns the previous transmitted byte at the end of the timeout period.
- ▶ The receive FIFO is full when another byte is about to be received. If the receive FIFO has still not been read at the end of the timeout period, a no acknowledge is returned, and the master ends the sequence with a stop condition.

The stretch timeout period is calculated as follows:

$$\text{Stretch Timeout Period in Master Mode} = PCLK1_PERIOD \times (\text{Prescale} + 1) \times (\text{High} + \text{Low}) \times 2^{ASTRETSCL, \text{ Bits}[3:0]} \quad (16)$$

where:

Prescale is the prescaler for the SCLx clock via TCTL, Bits[11:9].

High is the high period of the clock, via I²C DIV, Bits[15:8].

Low is the low period of the clock, via I²C DIV, Bits[7:0].

ASTRETSCL, Bits[3:0] = 0b0001 to 0b1110 (2¹ to 2¹⁴). The timeout period is infinite if *ASTRETSCL, Bits[3:0]* = 0b1111.

$$\text{Stretch Timeout Period in Slave Mode} = PCLK1_PERIOD \times (\text{Prescale} + 1) \times (\text{High} + \text{Low}) \times 2^{ASTRETSCL, \text{ Bits}[7:4]} \quad (17)$$

where:

Prescale is the prescaler for the SCLx clock via TCTL, Bits[11:9].

High is the high period of the clock, via I²C DIV, Bits[15:8].

Low is the low period of the clock, via I²C DIV, Bits[7:0].

ASTRETSCL, Bits[7:4] = 0b0001 to 0b1110 (2¹ to 2¹⁴). The timeout period is infinite if *ASTRETSCL, Bits[7:4]* = 0b1111.

Master No Acknowledge

When receiving data, the master responds with a no acknowledge if its FIFO is full and an attempt is made to write another byte to the FIFO. This last byte received is not written to the FIFO and is lost.

No Acknowledge From the Slave

If the slave does not want to acknowledge a read access, not writing data into the slave transmit FIFO results in a no acknowledge.

If the slave does not want to acknowledge a master write, assert the no acknowledge bit in the slave control register, SCTL, Bit 7.

Normally, the slave acknowledges all bytes written into the receive FIFO. If the receive FIFO fills up, the slave cannot write further bytes to the FIFO, and the slave does not acknowledge subsequent bytes not written to the FIFO. The master must then stop the transaction.

The slave does not acknowledge a matching device address if the read/write bit is set and the transmit FIFO is empty. Therefore, there is very little time for the microcontroller to respond to a slave transmit request and the assertion of an acknowledge. It is recommended that EARLYTXR (SCTL, Bit 5) be asserted for this reason.

General Call

An I²C general call is for addressing every device on the I²C bus. A general call address is 0x00 or 0x01. The first byte, the address byte, is followed by a command byte.

If the address byte is 0x00, Byte 2 (the command byte) can be one of the following:

- ▶ 0x6: the I²C interface (master and slave) is reset. The general call interrupt status asserts, and the general call ID bits, GCID (SSTAT, Bits[9:8]), are 0x1. User code must take corrective action to reset the entire system or simply reenables the I²C interface.
- ▶ 0x4: the general call interrupt status bit is asserted, and the general call ID bits (GCID) are 0x2.

If the address byte is 0x01, a hardware general call is issued. Byte 2 in this case is the hardware master address.

The general call interrupt status bit is set on any general call after the second byte is received, and user code must take corrective action to reprogram the device address.

If SCTL, Bit 2 (GCEN) is set to 1, the slave always acknowledges the first byte of a general call. The slave acknowledges the second byte of a general call if the second byte is 0x04 or 0x06, or if the second byte is a hardware general call and HGCEN (SCTL[3]) is set to 1.

I²C SERIAL INTERFACES

The I²C ALT register contains the alternate device ID for a hardware general call sequence. If the hardware general call enable bit (HGCEN), the general call enable bit (GCEN), and the slave enable bit (SLVEN) are all set, the device recognizes a hardware general call. When a general call sequence is issued and the second byte of the sequence is identical to ALT, the hardware call sequence is recognized for the device.

I²C Reset Mode

The slave state machine is reset when SLVEN is written to 0. The master state machine is reset when MASEN is written to 0.

I²C Test Modes

The device can be placed in an internal loopback mode by setting the loopback bit (MCTL, Bit 2). There are four FIFOs (master transmit and receive, and slave transmit and receive). Therefore, the I²C peripheral can, in effect, be set up to talk to itself. External loopback can be performed if the master is set up to address the slave address.

I²C Low Power Mode

If the master and slave are both disabled (MASEN = SLVEN = 0), the I²C section is off.

Power-Down Considerations

The following points must be considered when the device is being powered down to hibernate mode. If the master or slave is idle (which can be known from the respective status registers), it can be immediately disabled by clearing the MASEN bit in the MCTL master control register or the SLVEN bit in the SCTL slave control register, respectively.

If the MASEN and SLVEN bits are active, there are four scenarios as follows:

- ▶ I²C is a master and is receiving data. In this case, the device receives data based on the count programmed in the MRXCNT register. The device is in continuous read mode if the extend bit (MRXCNT, Bit 8) is set. To stop the read transfer, clear the extend bit and assign the MRXCNT register with the count value + 1, where the count value in the MCRXCNT register gives the current read count. The +1 signifies that there is some room for the completion. If the newly programmed value is less than the current count, the master receives until the current count overflows and reaches the programmed count, which ends the transfer after receiving the next byte. After the transaction complete interrupt is received, the core disables the master by clearing the MASEN bit in the MCTL register.
- ▶ I²C is a master and it is transmitting data. The software flushes the transmit FIFO by setting MFLUSH (STAT, Bit 9) and disables the transmit request by clearing IENMTX (MCTL, Bit 5), which ends the current transfer after transmitting the byte in progress. When the transaction complete interrupt is received, the user code clears the MASEN bit in the MCTL register.

Disabling the master before completion can cause the bus to hang indefinitely.

- ▶ I²C is a slave and is receiving data. The software sets the NACK bit (Bit 7) in the SCTL register. Setting the NACT bit gives a no acknowledge for the next communication, after which the external master must stop. On receiving the stop interrupt, the core disables the slave by clearing the SLVEN bit of the SCTL register.
- ▶ I²C is a slave and it does transmit. After slave transmit starts, it cannot no acknowledge any further transactions (acknowledge is driven only by the master). Therefore, the slave must wait until the external master issues a stop condition. After receiving the stop interrupt, the slave can be disabled. This method is a safe way to exit. However, if the slave must be disabled immediately, it can be done only at the cost of wrong data being transmitted (0xFF), because the SDAx line is not driven anymore, and is pulled up during data phase. Note that the bus does not hang in this case.

DMA Requests

Nine DMA channels in total are provided to service the I²C master and slave for each I²C port (three DMA channels per port).

DMA enable bits are provided in the slave control register and in the master control register.

I²C SERIAL INTERFACESREGISTER SUMMARIES: I²C MASTER/SLAVE I2C0, I2C1, AND I2C2

Table 122. I2C0 Register Summary

Address	Name	Description	Reset	Access
0x40020800	MCTL	Master Control.	0x0000	R/W
0x40020804	MSTAT	Master Status.	0x6000	R/W
0x40020808	MRX	Master Receive Data.	0x0000	R
0x4002080C	MTX	Master Transmit Data.	0x0000	R/W
0x40020810	MRXCNT	Master Receive Data Count.	0x0000	R/W
0x40020814	MCRXCNT	Master Current Receive Data Count.	0x0000	R
0x40020818	ADDR0	First Master Address Byte.	0x0000	R/W
0x4002081C	ADDR1	Second Master Address Byte.	0x0000	R/W
0x40020820	BYT	Start Byte.	0x0000	R/W
0x40020824	DIV	Serial Clock Period Divisor.	0xC6C7	R/W
0x40020828	SCTL	Slave Control.	0x0000	R/W
0x4002082C	SSTAT	Slave I ² C Status/Error/IRQ.	0x0001	R/W
0x40020830	SRX	Slave Receive.	0x0000	R
0x40020834	STX	Slave Transmit.	0x0000	R/W
0x40020838	ALT	Hardware General Call ID.	0x0000	R/W
0x4002083C	ID0	First Slave Address Device ID.	0x0000	R/W
0x40020840	ID1	Second Slave Address Device ID.	0x0000	R/W
0x40020844	ID2	Third Slave Address Device ID.	0x0000	R/W
0x40020848	ID3	Fourth Slave Address Device ID.	0x0000	R/W
0x4002084C	STAT	Master and Slave FIFO Status.	0x0000	R/W
0x40020850	SHCTL	Shared Control.	0x0000	R/W
0x40020854	TCTL	Timing Control.	0x0205	R/W
0x40020858	ASTRETCHSCL	Automatic Stretch SCLx.	0x0000	R/W
0x4002085C	IDFSTA	ID FIFO Status Register.	0x0000	R/W
0x40020860	SLVADDR1	Slave 10-Bit Address, First Byte.	0x0000	R/W
0x40020864	SLVADDR2	Slave 10-Bit Address, Second Byte.	0x0000	R/W
0x40020868	SSTAT2	Slave I ² C Status/IRQ 2.	0x0000	R

Table 123. I2C1 Register Summary

Address	Name	Description	Reset	Access
0x40020C00	MCTL	Master Control.	0x0000	R/W
0x40020C04	MSTAT	Master Status.	0x6000	R/W
0x40020C08	MRX	Master Receive Data.	0x0000	R
0x40020C0C	MTX	Master Transmit Data.	0x0000	R/W
0x40020C10	MRXCNT	Master Receive Data Count.	0x0000	R/W
0x40020C14	MCRXCNT	Master Current Receive Data Count.	0x0000	R
0x40020C18	ADDR0	First Master Address Byte.	0x0000	R/W
0x40020C1C	ADDR1	Second Master Address Byte.	0x0000	R/W
0x40020C20	BYT	Start Byte.	0x0000	R/W
0x40020C24	DIV	Serial Clock Period Divisor.	0xC6C7	R/W
0x40020C28	SCTL	Slave Control.	0x0000	R/W
0x40020C2C	SSTAT	Slave I ² C Status/Error/IRQ.	0x0001	R/W
0x40020C30	SRX	Slave Receive.	0x0000	R
0x40020C34	STX	Slave Transmit.	0x0000	R/W
0x40020C38	ALT	Hardware General Call ID.	0x0000	R/W
0x40020C3C	ID0	First Slave Address Device ID.	0x0000	R/W
0x40020C40	ID1	Second Slave Address Device ID.	0x0000	R/W
0x40020C44	ID2	Third Slave Address Device ID.	0x0000	R/W

I²C SERIAL INTERFACES

Table 123. I2C1 Register Summary (Continued)

Address	Name	Description	Reset	Access
0x40020C48	ID3	Fourth Slave Address Device ID.	0x0000	R/W
0x40020C4C	STAT	Master and Slave FIFO Status.	0x0000	R/W
0x40020C50	SHCTL	Shared Control.	0x0000	R/W
0x40020C54	TCTL	Timing Control Register.	0x0205	R/W
0x40020C58	ASTRETCHSCL	Automatic Stretch SCLx.	0x0000	R/W
0x40020C5C	IDFSTA	ID FIFO Status.	0x0000	R/W
0x40020C60	SLVADDR1	Slave 10 Bits Address First Byte.	0x0000	R/W
0x40020C64	SLVADDR2	Slave 10 Bits Address Second Byte.	0x0000	R/W
0x40020C68	SSTAT2	Slave I ² C Status/IRQ 2.	0x0000	R

Table 124. I2C2 Register Summary

Address	Name	Description	Reset	Access
0x40021000	MCTL	Master Control.	0x0000	R/W
0x40021004	MSTAT	Master Status.	0x6000	R/W
0x40021008	MRX	Master Receive Data.	0x0000	R
0x4002100C	MTX	Master Transmit Data.	0x0000	R/W
0x40021010	MRXCNT	Master Receive Data Count.	0x0000	R/W
0x40021014	MCRXCNT	Master Current Receive Data Count.	0x0000	R
0x40021018	ADDR0	First Master Address Byte.	0x0000	R/W
0x4002101C	ADDR1	Second Master Address Byte.	0x0000	R/W
0x40021020	BYT	Start Byte.	0x0000	R/W
0x40021024	DIV	Serial Clock Period Divisor.	0xC6C7	R/W
0x40021028	SCTL	Slave Control.	0x0000	R/W
0x4002102C	SSTAT	Slave I ² C Status/Error/IRQ.	0x0001	R/W
0x40021030	SRX	Slave Receive.	0x0000	R
0x40021034	STX	Slave Transmit.	0x0000	R/W
0x40021038	ALT	Hardware General Call ID.	0x0000	R/W
0x4002103C	ID0	First Slave Address Device ID.	0x0000	R/W
0x40021040	ID1	Second Slave Address Device ID.	0x0000	R/W
0x40021044	ID2	Third Slave Address Device ID.	0x0000	R/W
0x40021048	ID3	Fourth Slave Address Device ID.	0x0000	R/W
0x4002104C	STAT	Master and Slave FIFO Status.	0x0000	R/W
0x40021050	SHCTL	Shared Control.	0x0000	R/W
0x40021054	TCTL	Timing Control Register.	0x0205	R/W
0x40021058	ASTRETCHSCL	Automatic Stretch SCLx.	0x0000	R/W
0x4002105C	IDFSTA	ID FIFO Status.	0x0000	R/W
0x40021060	SLVADDR1	Slave 10-Bit Address, First Byte.	0x0000	R/W
0x40021064	SLVADDR2	Slave 10-Bit Address, Second Byte.	0x0000	R/W
0x40021068	SSTAT2	Slave I ² C Status/IRQ 2.	0x0000	R

I²C SERIAL INTERFACESREGISTER DETAILS: I²C MASTER/SLAVE I2C0, I2C1, AND I2C2
Master Control Register

Address: 0x40020800, Reset: 0x0000, Name: MCTL

Table 125. Bit Descriptions for MCTL

Bits	Bit Name	Settings	Description	Reset	Access
15	RESERVED		Reserved.	0x0	R/W
14	RESERVED		Reserved.	0x0	R/W
13	PRESTOP_BUS_CLR		Prestop Bus Clear. Use this bit in conjunction with BUS_CLR_EN. If this bit is set, the master stops sending SCLx clocks if SDAx is released before 9 SCLx cycles.	0x0	R/W
12	BUS_CLR_EN		Bus Clear Enable. If this bit is set, the master initiates a bus clear operation by sending up to 9 extra SCLx cycles if arbitration was lost. This bit is added to come out of an SDAx stuck situation due to a misbehaving slave. Therefore, use this bit with caution. Set this bit only when there is no other active I ² C master.	0x0	R/W
11	MTXDMA		Enable Master Tx DMA Request. 1 Set to 1 by user code to enable I ² C master DMA Tx requests. 0 Cleared by user code to disable DMA mode.	0x0	W
10	MRXDMA		Enable Master Rx DMA Request. 1 Set to 1 by user code to enable I ² C master DMA Rx requests. 0 Cleared by user code to disable DMA mode.	0x0	W
9	MXMITDEC		Decrement Master Tx FIFO Status When Transmitted One Byte. 1 If set to 1, the master transmit FIFO status is decremented when a byte has been transmitted. 0 If set to 0, the master transmit FIFO status is decremented when the byte is unloaded from the FIFO into a shadow register at the start of the byte transmission.	0x0	R/W
8	IENCMP		Transaction Completed (Or Stop Detected) Interrupt Enable. When set to 1, an interrupt is generated when a stop condition is detected.	0x0	R/W
7	IENACK		Acknowledge Not Received Interrupt Enable. When set to 1, an interrupt is generated when a no acknowledge is returned by a slave.	0x0	R/W
6	IENALOST		Arbitration Lost Interrupt Enable. When set to 1, an interrupt is generated when the master loses control of the bus and when arbitration is lost.	0x0	R/W
5	IENMTX		Transmit Request Interrupt Enable. When set to 1, an interrupt is generated when a byte transmit is completed.	0x0	R/W
4	IENMRX		Receive Request Interrupt Enable. When set to 1, an interrupt is generated when a byte is received.	0x0	R/W
3	RESERVED		Reserved.	0x0	R/W
2	LOOPBACK		Internal Loopback Enable. When this bit is set, SCLx and SDAx out of the device are multiplexed onto their corresponding inputs. Note that it is also possible for the master to loop back a transfer to the slave if the device address corresponds, that is, external loopback.	0x0	R/W
1	COMPETE		Start Backoff Disable. Setting this bit enables the device to compete for ownership even if another device is currently driving a start condition.	0x0	R/W
0	MASEN		Master Enable. 1 When the bit is 1, the master is enabled. 0 When the bit is 0, all master state machine flops are held in reset and the master is disabled. Disable the master when not in use because the disable gates the clock to the master and saves power. Do not clear this bit until a transaction has completed. See the TCCOMP bit in the master status register. Note that APB writable register bits are not reset by this bit. Cleared by default.	0x0	R/W

I²C SERIAL INTERFACES

Master Status Register

Address: 0x40020804, Reset: 0x6000, Name: MSTAT

Table 126. Bit Descriptions for MSTAT

Bits	Bit Name	Settings	Description	Reset	Access
15	Reserved		Reserved	0x0	R
14	SCL_FILTERED		State of SCLx Line. This bit is the output of the glitch filter on SCLx. SCLx is always pulled high when undriven.	0x1	R
13	SDA_FILTERED		State of SDAx Line. This bit is the output of the glitch filter on SDAx. SDAx is always pulled high when undriven.	0x1	R
12	MTXUFLOW		Master Transmit Underflow. Set to 1 when the I ² C master ends the transaction due to Tx FIFO empty condition. This bit is asserted only when the IENMTX bit is set.	0x0	RC
11	MSTOP		Stop Condition Driven by This I ² C Master. Set to 1 when this I ² C master drives a stop condition on the I ² C bus. This bit, when set, can indicate a transaction completion, Tx underflow, Rx overflow, or a no acknowledge by the slave. This bit is different from the TCOMP because this bit is not asserted when the stop condition occurs due to any other I ² C master. No interrupt is generated when this bit is set. However, if IENCOMP is 1, every stop condition generates an interrupt and this bit can be read. When this bit is read, it clears to 0. Read this bit only if IENCOMP in MCTL is set to 1.	0x0	RC
10	LINEBUSY		I ² C Bus is Busy. 1 Set to 1 when a start is detected on the I ² C bus. 0 Cleared to 0 when a stop is detected on the I ² C bus.	0x0	R
9	MRXOF		Master Receive FIFO Overflow. 1 Set to 1 when a byte is written to the receive FIFO when the FIFO is already full. 0 When the bit is read, this bit clears to 0.	0x0	RC
8	TCOMP		Transaction Complete or Stop Detected. Set to 1 when a stop condition is detected on the I ² C bus. If IENCOMP is 1, an interrupt is generated when this bit is set. This bit is only set to 1 if the master is enabled (MASEN = 1 in the MCTL register). Use this bit to determine when it is safe to disable the master. It can also be used to wait for another master transaction to complete on the I ² C bus when this master loses arbitration. When read, this bit clears to 0. This bit can drive an interrupt.	0x0	RC
7	NACKDATA		No Acknowledge Received in Response to Data Write. Set to 1 when a no acknowledge is received in response to a data write transfer. If IENNACK is 1, an interrupt is generated when this bit is set to 1. This bit can drive an interrupt. This bit is cleared on a read of the MSTAT register.	0x0	RC
6	MBUSY		Master Busy. When set to 1, this bit indicates that the master state machine is servicing a transaction. It clears to 0 if the state machine is idle or another device has control of the I ² C bus.	0x0	R
5	ALOST		Arbitration Lost. This bit is set to 1 if the master loses arbitration. If IENALOST = 1 in the MCTL register, an interrupt is generated when this bit is set to 1. This bit is cleared on a read of the MSTAT register. This bit can drive an interrupt.	0x0	RC
4	NACKADDR		Acknowledge Not Received in Response to an Address. This bit sets to 1 if a no acknowledge is received in response to an address. If IENNACK is 1, an interrupt is generated when this bit is set to 1. This bit is cleared on a read of the MSTAT register. This bit can drive an interrupt.	0x0	RC
3	MRXREQ		Master Receive Request. This bit is set to 1 when there is data in the receive FIFO. If IENMRX = 1 in the MCTL register, an interrupt is generated when this bit is set to 1. This bit can drive an interrupt. The bit is cleared to 0 if the receive FIFO is empty.	0x0	R
2	MTXREQ		Master Transmit Interrupt Bit. This bit is set to 1 when the direction bit is 0 (write) and the transmit FIFO is not full. If TXRIEN is 1, an interrupt is generated when this bit is set to 1. This bit is cleared to 0 by loading the transmit FIFO or with a stop or start condition.	0x0	R/W
[1:0]	MTXFSTA		Master Transmit FIFO Status. These 2 bits show the master transmit FIFO status and can be decoded as follows: 00, 01 FIFO empty. 10 1 byte in FIFO. 11 FIFO full.	0x0	R

I²C SERIAL INTERFACES**Master Receive Data Register**

Address: 0x40020808, Reset: 0x0000, Name: MRX

Table 127. Bit Descriptions for MRX

Bits	Bit Name	Settings	Description	Reset	Access
[15:8]	RESERVED		Reserved.	0x0	R
[7:0]	ICMRX		Master Receive Register. This register allows access to the receive data FIFO. The FIFO can hold 2 bytes.	0x0	R

Master Transmit Data Register

Address: 0x4002080C, Reset: 0x0000, Name: MTX

Table 128. Bit Descriptions for MTX

Bits	Bit Name	Settings	Description	Reset	Access
[15:8]	RESERVED		Reserved.	0x0	R
[7:0]	I2CMTX		Master Transmit Register. This register allows access to the transmit data FIFO. The FIFO can hold 2 bytes.	0x0	R/W

Master Receive Data Count Register

Address: 0x40020810, Reset: 0x0000, Name: MRXCNT

Table 129. Bit Descriptions for MRXCNT

Bits	Bit Name	Settings	Description	Reset	Access
[15:9]	RESERVED		Reserved.	0x0	R
8	EXTEND		Extended Read. Use this bit if greater than 256 bytes are required in a single read sequence. For example, to receive 412 bytes, write 0x100 (extend = 1) to the MRXCNT register. Wait for the first byte to be received, then check the MCRXCNT register for every byte received thereafter. When Count[7:0] returns to 0, 256 bytes have been received. Then write 0x09C to the MRXCNT register.	0x0	R/W
[7:0]	COUNT		Receive Count. Program the number of bytes required minus one to this register. If just 1 byte is required, write 0 to this register. If greater than 256 bytes are required, use the extend bit.	0x0	R/W

Master Current Receive Data Count Register

Address: 0x40020814, Reset: 0x0000, Name: MCRXCNT

Table 130. Bit Descriptions for MCRXCNT

Bits	Bit Name	Settings	Description	Reset	Access
[15:8]	RESERVED		Reserved.	0x0	R
[7:0]	COUNT		Current Receive Count. This register gives the total number of bytes received so far minus 1. If 257 bytes are requested, this register reads 0 when the transaction has completed.	0x0	R

First Master Address Byte Register

Address: 0x40020818, Reset: 0x0000, Name: ADDR0

Table 131. Bit Descriptions for ADDR0

Bits	Bit Name	Settings	Description	Reset	Access
[15:8]	RESERVED		Reserved.	0x0	R
[7:0]	ADR1		Address Byte 1. If a 7 bit address is required, Bit 7 to Bit 1 of ADR1 are programmed with the address and Bit 0 of ADR1 is programmed with the direction (read or write). If a 10-bit address is required, Bit 7 to Bit 3 of ADR1 are programmed with 11110, Bit 2 to Bit 1 of ADR1 are programmed with the 2 MSBs of the address, and Bit 0 of ADR1 is programmed to 0.	0x0	R/W

I²C SERIAL INTERFACES

Second Master Address Byte Register

Address: 0x4002081C, Reset: 0x0000, Name: ADDR1

Table 132. Bit Descriptions for ADDR1

Bits	Bit Name	Settings	Description	Reset	Access
[15:8]	RESERVED		Reserved.	0x0	R
[7:0]	ADR2		Address Byte 2. This register is only required when addressing a slave with a 10-bit address. Bit 7 to Bit 0 of ADDR2 are programmed with the lower 8 bits of the address.	0x0	R/W

Start Byte Register

Address: 0x40020820, Reset: 0x0000, Name: BYT

Table 133. Bit Descriptions for BYT

Bits	Bit Name	Settings	Description	Reset	Access
[15:8]	RESERVED		Reserved.	0x0	R
[7:0]	SBYTE		Start Byte. This register can be used to generate a start byte at the start of a transaction. To generate a start byte followed by a normal address, first write to MTX, then write to the address register (ADDR0). This writing to ADDR0 drives the byte written in MTX on to the bus followed by a repeated start. This register can be used to drive any byte on to the I ² C bus followed by a repeated start byte.	0x0	R/W

Serial Clock Period Divisor Register

Address: 0x40020824, Reset: 0xC6C7, Name: DIV

Table 134. Bit Descriptions for DIV

Bits	Bit Name	Settings	Description	Reset	Access
[15:8]	HIGH		Serial Clock High Time. These bits control the SCLx clock high time. The timer is driven by PCLK1. See the I²C Clock Control section.	0xC6	R/W
[7:0]	LOW		Serial Clock Low Time. These bits control the SCLx clock low time. The timer is driven by PCLK1. See the I²C Clock Control section.	0xC7	R/W

Slave Control Register

Address: 0x40020828, Reset: 0x0000, Name: SCTL

Table 135. Bit Descriptions for SCTL

Bits	Bit Name	Settings	Description	Reset	Access
15	ID_FIFO_EN		ID FIFO Enable. If this bit set to 1, each slave device ID has a separate transmit FIFO.	0x0	R/W
14	STXDMA	1 0	Enable Slave Tx DMA Request. Set to 1 to enable I ² C slave DMA Rx requests. Cleared by user code to disable DMA mode.	0x0	R/W
13	SRXDMA		Enable Slave Rx DMA Request. Set to 1 by user code to enable I ² C slave DMA Rx requests. Cleared by user code to disable DMA mode.	0x0	R/W
12	IENREPST	1 0	Repeated Start Interrupt Enable. An interrupt is generated when the REPSTART status bit is set to 1. An interrupt is not generated when the REPSTART status bit is set.	0x0	R/W
11	SXMITDEC	1 0	Decrement Slave Tx FIFO Status When Transmitted a Byte. The transmit FIFO status is decremented when a byte has been transmitted. The transmit FIFO status is decremented when the byte is unloaded from the FIFO into a shadow register at the start of byte transmission.	0x0	R/W
10	IENSTX		Set to 1 to enable the Slave Transmit Request Interrupt Enable.	0x0	R/W
9	IENSRX		Set to 1 to enable the Slave Receive Request Interrupt Enable.	0x0	R/W
8	IENSTOP		Set to 1 to enable the Stop Condition Detected Interrupt Enable.	0x0	R/W

I²C SERIAL INTERFACES

Table 135. Bit Descriptions for SCTL (Continued)

Bits	Bit Name	Settings	Description	Reset	Access
7	NACK		No Acknowledge Next Communication. Set this bit to 1 to no acknowledge the next I ² C communication. This bit can only be set in nonstretch mode.	0x0	R/W
6	Reserved		Reserved.	0x0	R/W
5	EARLYTXR	1 0	Early Transmit Request Mode. Set to 1 to enable a transmit request just after the rising edge of the direction bit SCLx clock pulse. When cleared to 0, the transmit request interrupt is asserted just after the falling edge of the direction bit SCLx clock pulse.	0x0	R/W
4	GCSBCLR		General Call Status Bit Clear. The general call status and general call ID bits are cleared when a 1 is written to this bit. The general call status and general call ID bits are not reset by anything other than a write to this bit or a full reset.	0x0	W
3	HGCEN		Hardware General Call Enable. When this bit and the general call enable bit are set, after receiving a general call and address of 0x00 and a data byte, checks the contents of the ALT register against the receive shift register. If they match, the device has received a hardware general call. This is used if a device needs urgent attention from a master device without knowing which master it needs to turn to. This is a call to whom it may concern. The device that requires attention embeds its own address into the message. The LSB of the ALT register must always be written to a 1, as per I ² C January 2000 specification.	0x0	R/W
2	GCEN		General Call Enable. This bit enables the I ² C slave to acknowledge an I ² C general call, Address 0x00 (write).	0x0	R/W
1	ADR10EN	1 0	Enabled 10-bit Addressing. When this bit is set to 1, 10-bit addressing is enabled. One 10-bit address is supported by the slave and is stored in ID0 and ID1, where ID0 contains the first byte of the address and the upper 5 bits must be programmed to 11110. ID3 and ID4 can be programmed with 7-bit addresses at the same time. If this bit is cleared to 0, the slave can support four slave addresses, programmed in Register ID0 to Register ID3.	0x0	R/W
0	SLVEN	1 0	Slave Enable. Set to 1 to enable slave mode. When cleared to 0, all slave state machine flops are held in reset and the slave is disabled. Note that APB writable register bits are not reset.	0x0	R/W

Slave I²C Status/Error/IRQ Register

Address: 0x4002082C, Reset: 0x0001, Name: SSTAT

Table 136. Bit Descriptions for SSTAT

Bits	Bit Name	Settings	Description	Reset	Access
15	SLV_HS_MODE		Slave High Speed Mode. Set to 1 if high speed master code (00001xxx) is received. After stop, this bit is cleared.	0x0	R
14	START	1 0	Start and Matching Address. Set to 1 if one of the following is received: Start + matching device address, a general call (0000_0000) code and general call is enabled, high speed (0000_1XXX) code is received, or a start byte (0000_0001) is received. It is cleared to 0 after a stop or start condition is received.	0x0	R
13	REPSTART	1 0	Repeated Start and Matching Address. This bit can drive an interrupt. Set to 1 if a start is already asserted and then a repeated start is detected. It is cleared when read or on receiving a stop condition.	0x0	RC
[12:11]	IDMAT	00 01 10 11	Device ID Matched. Received Address Matched ID Register 0. Received Address Matched ID Register 1. Received Address Matched ID Register 2. Received Address Matched ID Register 3.	0x0	R
10	STOP		Stop After Start and Matching Address.	0x0	RC

I²C SERIAL INTERFACES

Table 136. Bit Descriptions for SSTAT (Continued)

Bits	Bit Name	Settings	Description	Reset	Access
		1	Set to 1 if the slave device received a stop condition after a previous start condition and a matching address. If IENSTOP in the slave control register is set to 1, the slave interrupt request asserts when this bit is set.		
		0	Cleared to 0 by a read of the status register.		
[9:8]	GCID		General ID. GCID is cleared when the GCSBCLR is written to 1. These status bits are not cleared by a general call reset.	0x0	R
		00	No general call.		
		01	General call reset and program address.		
		10	General call program address.		
		11	General call matching alternative ID.		
7	GCINT		General Call Interrupt. This bit always drives an interrupt. Set to 1 if the slave device receives a general call of any type. To clear, write 1 to the GCSBCLR bit in the slave control register. If a general call reset was received, all registers are at their default values. If it was a hardware general call, the Rx FIFO holds the second byte of the general call, and this byte can be compared with the ALT register.	0x0	R
6	SBUSY		Slave Busy.	0x0	R
		1	Set to 1 if the slave device receives an I ² C start condition.		
		0	Cleared to 0 when the address does not match an ID register, or if the slave device receives an I ² C stop condition, or if a repeated start + address does not match any ID register.		
5	NOACK		Acknowledge Not Generated by the Slave. Set to 1 if the slave responded to its device address with a no acknowledge. It is set if there was no data to transmit and the sequence was a slave read, or if the NACK bit was set in the slave control register and the device was addressed. This bit is cleared on a read of the SSTAT register.	0x0	RC
4	SRXOF		Slave Receive FIFO Overflow. Set to 1 when a byte is written to the slave receive FIFO when the FIFO is already full. This bit is cleared on a read of the SSTAT register.	0x0	RC
3	SRXREQ		Slave Receive Request. Set to 1 whenever the slave receive FIFO is not empty. Read or flush the slave receive FIFO to clear this bit. This bit asserts on the falling edge of the SCLx clock pulse that clocks in the last data bit of a byte. This bit can drive an interrupt.	0x0	RC
2	STXREQ		Slave Transmit Interrupt Bit. This bit is set to 1 when the direction bit for a transfer is received high. Thereafter, if the transmit FIFO is not full, this bit remains set. If EARLYTXR = 0 in the SCTL register, this bit is set to 1 on the falling edge of the SCLx pulse that clocks in the direction bit (if the device address matched also). If EARLYTXR = 1 in the SCTL register, this bit is set to 1 on the rising edge of the SCLx pulse that clocks in the direction bit (if the device address matched also). A write to STX clears this bit.	0x0	R/W
1	STXUR		Slave Transmit FIFO Underflow. Set to 1 if a master requests data from the device, and the Tx FIFO is empty.	0x0	RC
0	STXFSERREQ		Slave Tx FIFO Status or Early Request. If EARLYTXR = 0, this bit is set to 1 whenever the slave Tx FIFO is empty. If EARLYTXR = 1, this bit is set when the direction bit for a transfer is received high. This bit sets on the positive edge of the SCLx clock pulse that clocks in the direction bit (if the device address matched also). This bit asserts only once for a transfer. It is cleared when SSTAT is read.	0x1	R/W

Slave Receive Register

Address: 0x40020830, Reset: 0x0000, Name: SRX

Table 137. Bit Descriptions for SRX

Bits	Bit Name	Settings	Description	Reset	Access
[15:8]	RESERVED		Reserved.	0x0	R
[7:0]	I2CSRX		Slave Receive Register.	0x0	R

I²C SERIAL INTERFACES

Slave Transmit Register

Address: 0x40020834, Reset: 0x0000, Name: STX

Table 138. Bit Descriptions for STX

Bits	Bit Name	Settings	Description	Reset	Access
[15:10]	RESERVED		Reserved.	0x0	R
[9:8]	ID_SEL		ID FIFO Select. Select which ID FIFO is loaded into STX data. ID_FIFO_EN in the SCTL register must be set to 1 for these bits to work. 00 Select Address Matched ID0. 01 Select Address Matched ID1. 10 Select Address Matched ID2. 11 Select Address Matched ID3.	0x0	R/W
[7:0]	I2CSTX		Slave Transmit Register.	0x0	R/W

Hardware General Call ID Register

Address: 0x40020838, Reset: 0x0000, Name: ALT

Table 139. Bit Descriptions for ALT

Bits	Bit Name	Settings	Description	Reset	Access
[15:8]	RESERVED		Reserved.	0x0	R
[7:0]	ALT		Slave Alternative Bits. These bits are used in conjunction with HGCEN in the SCTL register to match a master generating a hardware general call. ALT is used when a master device cannot be programmed with a slave address and instead the slave must recognize the master address.	0x0	R/W

First Slave Address Device ID Register

Address: 0x4002083C, Reset: 0x0000, Name: ID0

Table 140. Bit Descriptions for ID0

Bits	Bit Name	Settings	Description	Reset	Access
[15:8]	RESERVED		Reserved.	0x0	R
[7:0]	ID0		Slave Device ID0. ID0[7:1] is programmed with the device ID. ID0[0] is do not care. See the ADR10EN bit in the slave control register to see how this register is programmed with a 10-bit address.	0x0	R/W

Second Slave Address Device ID Register

Address: 0x40020840, Reset: 0x0000, Name: ID1

Table 141. Bit Descriptions for ID1

Bits	Bit Name	Settings	Description	Reset	Access
[15:8]	RESERVED		Reserved.	0x0	R
[7:0]	ID1		Slave Device ID1. ID1[7:1] is programmed with the device ID. ID1[0] is do not care. See the ADR10EN bit in the slave control register to see how this register is programmed with a 10-bit address.	0x0	R/W

Third Slave Address Device ID Register

Address: 0x40020844, Reset: 0x0000, Name: ID2

Table 142. Bit Descriptions for ID2

Bits	Bit Name	Settings	Description	Reset	Access
[15:8]	RESERVED		Reserved.	0x0	R
[7:0]	ID2		Slave Device ID2. ID2[7:1] is programmed with the device ID. ID2[0] is do not care. See the ADR10EN bit in the slave control register to see how this register is programmed with a 10-bit address.	0x0	R/W

I²C SERIAL INTERFACES

Fourth Slave Address Device ID Register

Address: 0x40020848, Reset: 0x0000, Name: ID3

Table 143. Bit Descriptions for ID3

Bits	Bit Name	Settings	Description	Reset	Access
[15:8]	RESERVED		Reserved.	0x0	R
[7:0]	ID3		Slave Device ID3. ID3[7:1] is programmed with the device ID. ID3[0] is do not care. See the ADR10EN bit in the slave control register to see how this register is programmed with a 10-bit address.	0x0	R/W

Master and Slave FIFO Status Register

Address: 0x4002084C, Reset: 0x0000, Name: STAT

Table 144. Bit Descriptions for STAT

Bits	Bit Name	Settings	Description	Reset	Access
[15:11]	RESERVED		Reserved.	0x0	R
10	STX_FLUSH_ALL		Flush the Entire Slave Transmit ID FIFOs. If ID_FIFO_EN = 1 in the SCTL register, and this bit is set, slave transmit FIFOs of all four devices are flushed.	0x0	R/W
9	MFLUSH		Flush the Master Transmit FIFO. Writing a 1 to this bit flushes the master transmit FIFO. The master transmit FIFO must be flushed if arbitration is lost or a slave responds with a no acknowledge. User must clear this bit to 0 for the master FIFO to work as normal.	0x0	W
8	SFLUSH		Flush the Slave Transmit FIFO. Writing a 1 to this bit flushes the slave transmit FIFO. User must clear this bit to 0 for the slave FIFO to work as normal. Use this bit when the slave ID FIFO is not used (SCTL, Bit 15 = 0).	0x0	W
[7:6]	MRXFSTA		Master Receive FIFO Status. The status is a count of the number of bytes in a FIFO. 00 FIFO empty. 01 1 byte in the FIFO. 10 2 bytes in the FIFO. 11 Reserved.	0x0	R
[5:4]	MTXSFA		Master Transmit FIFO Status. The status is a count of the number of bytes in a FIFO. 00 FIFO empty. 01 1 byte in the FIFO. 10 2 bytes in the FIFO. 11 Reserved.	0x0	R
[3:2]	SRXFSTA		Slave Receive FIFO Status. The status is a count of the number of bytes in a FIFO. 00 FIFO empty. 01 1 byte in the FIFO. 10 2 bytes in the FIFO. 11 Reserved.	0x0	R
[1:0]	STXFSTA		Slave Transmit FIFO Status. The status is a count of the number of bytes in a FIFO. 00 FIFO empty. 01 1 byte in the FIFO. 10 2 bytes in the FIFO. 11 Reserved.	0x0	R

I²C SERIAL INTERFACES

Shared Control Register

Address: 0x40020850, Reset: 0x0000, Name: SHCTL

Table 145. Bit Descriptions for SHCTL

Bits	Bit Name	Settings	Description	Reset	Access
[15:1]	RESERVED		Reserved	0x0	R/W
0	RESET		Write 1 to this bit to reset the I ² C start and stop detection circuits. Setting this bit resets the LINEBUSY status bit. Ensure this bit is cleared to 0 after it is set.	0x0	W

Timing Control Register

Address: 0x40020854, Reset: 0x0205, Name: TCTL

Table 146. Bit Descriptions for TCTL

Bits	Bit Name	Settings	Description	Reset	Access
[15:12]	FILTER_TICKS		SCLx and SDAX Glitch Filter Ticks. Determines in UCLK cycles the width of glitches that are filtered. $Glitch\ Filter\ Ticks \leq t_{SP}/PCLK1$ where t_{SP} is the pulse width of the spikes that must be suppressed by the input filter.	0x0	R/W
[11:9]	PRE_DIV		Prescale Divide Counter for SCLx. See the I²C Clock Control section.	0x1	R/W
8	FILTEROFF		Input Filter Control. 1 Set to 1 to enable the SCLx/SDAx glitch filter. 0 Clear to 0 to disable the SCLx/SDAx glitch filter.	0x0	R/W
[7:6]	RESERVED		Reserved.	0x0	R
[5:0]	THDATIN		Data in Hold Start. THDATIN determines the hold time requirement that must be met before a start or stop condition is recognized. The hold time observed between the SDAx and SCLx falling edges must exceed the programmed value to be recognized as a valid start. $THDATIN = t_{SHD}/(Clock\ Period)$ For example, at 16 MHz PCLK (62.5 ns) and setting a minimum t_{SHD} limit of 300 ns, $(300\ ns)/(62.5\ ns) = 5$.	0x5	R/W

Automatic Stretch SCLx Register

Address: 0x40020858, Reset: 0x0000, Name: ASTRECHSCL

Table 147. Bit Descriptions for ASTRECHSCL

Bits	Bit Name	Settings	Description	Reset	Access
15	CLR_ADDR_ACK_IRQ		Write Clear Address Acknowledge IRQ. Write 1 to clear the address acknowledge interrupt.	0x0	W
14	SSCL_IRQ_IEN		Slave Stretch Interrupt Enable. 1 Set to 1 to enable a slave mode interrupt when the I ² C slave hardware holds the SCLx pin low. Interrupt is asserted when the SSCL_IRQ bit is set to 1 in the SSTAT2 register. 0 Clear to 0 to disable this interrupt source.	0x0	R/W
13	ADDR_ACK_IEN		Slave Address Acknowledge Interrupt Enable. 1 Set to 1 to enable an interrupt when clock stretching occurs after the acknowledge of a bus address. Interrupt is asserted when ADDR_ACK_IRQ is set to 1 in the SSTAT2 register. 0 Clear to 0 to disable this interrupt source. Clear this bit by setting CLR_ADDR_ACK_IRQ = 1.	0x0	R/W
12	Reserved		Reserved	0x0	R/W
11	SSCL_AFTER_ACK		Slave Stretch After Acknowledge. 1 Set to 1 for hardware to hold SCLx low after ACK bit. Recommended setting. See Figure 16 for ACK bit details.	0x0	R/W

I²C SERIAL INTERFACES

Table 147. Bit Descriptions for ASTRETCHSCL (Continued)

Bits	Bit Name	Settings	Description	Reset	Access
		0	Clear to 0. Hardware stretch can happen before ACK bit.		
10	Reserved		Reserved	0x0	R/W
9	TIMEOUT_SSCL_SLV	1 0	Slave Automatic Stretch Timeout Status. Set to 1 when slave automatic stretch timeout occurs. Cleared to 0 when this bit read.	0x0	R
8	TIMEOUT_SSCL_MAS	1 0	Master Automatic Stretch Timeout status. Set to 1 when master automatic stretch timeout occurs. Cleared to 0 when this bit read.	0x0	R
[7:4]	STRETCH_MODE_SLV	0000 0001 to 1110 1111	Automatic Stretch Mode Control for Slave. These bits control automatic stretch mode for slave operation. These bits allow the slave to hold the SCLx line low and gain more time to service an interrupt, load a FIFO, or read a FIFO. Use the timeout feature to avoid a bus lockup condition where the slave indefinitely holds SCLx low. As a slave transmitter, SCLx is automatically stretched from the negative edge of SCLx (if the slave transmit FIFO is empty) before sending an acknowledge or no acknowledge for address byte, or before sending data for a data byte. Stretching stops when the slave transmit FIFO is no longer empty or a timeout occurs. As a slave receiver and SSCL_AFTER_ACK = 0, the SCLx clock is automatically stretched from the negative edge of SCLx before sending an acknowledge or no acknowledge when the slave receive FIFO is full. When SSCL_AFTER_ACK = 1, the SCLx clock is automatically stretched from the negative edge of SCLx before receiving data for a data byte when the slave receive FIFO is full. Stretching stops when the slave receive FIFO is no longer in an overflow condition or a timeout occurs. Automatic slave clock stretching disabled. Automatic slave clock stretching enabled. The timeout period is explained in the Automatic Clock Stretching section. Note that the I ² C bus baud rate has no influence on the slave stretch timeout period. Automatic slave clock stretching enabled with indefinite timeout period.	0x0	R/W
[3:0]	STRETCH_MODE_MAS	0000 0001 to 1110 1111	Automatic Stretch Mode Control for Master. These bits control automatic stretch mode for master operation. These bits allow the master to hold the SCLx line low and gain more time to service an interrupt, load a FIFO, or read a FIFO. Use the timeout feature to avoid a bus lockup condition where the master indefinitely holds SCLx low. As a master transmitter, SCLx is automatically stretched from the negative edge of SCLx (if the master transmit FIFO is empty) before sending an acknowledge or no acknowledge for an address byte, or before sending data for a data byte. Stretching stops when the master transmit FIFO is no longer empty or a timeout occurs. As a master receiver, the SCLx clock is automatically stretched from the negative edge of SCLx before receiving a data byte when the master receive FIFO is full. Stretching stops when the master receive FIFO is no longer in an overflow condition or when a timeout occurs. Do not change this value when communicating over the I ² C bus. Automatic master clock stretching disabled. Automatic master clock stretching enabled. The timeout period is explained in the Automatic Clock Stretching section. Automatic master clock stretching enabled with indefinite timeout period.	0x0	R/W

I²C SERIAL INTERFACES

ID FIFO Status Register

Address: 0x4002085C, Reset: 0x0000, Name: IDFSTA

Table 148. Bit Descriptions for IDFSTA

Bits	Bit Name	Settings	Description	Reset	Access
15	STX3UR		Slave Transmit ID3 FIFO Underflow. Set to 1 if a master requests data from the device, and the Tx FIFO is empty.	0x0	RC
14	STX2UR		Slave Transmit ID2 FIFO Underflow. Set to 1 if a master requests data from the device, and the Tx FIFO is empty.	0x0	RC
13	STX1UR		Slave Transmit ID1 FIFO Underflow. Set to 1 if a master requests data from the device, and the Tx FIFO is empty.	0x0	RC
12	STX0UR		Slave Transmit ID0 FIFO Underflow. Set to 1 if a master requests data from the device, and the Tx FIFO is empty.	0x0	RC
11	SFLUSH3		Flush the Slave Transmit ID3 FIFO. Writing a 1 to this bit flushes the slave transmit ID3 FIFO.	0x0	W
10	SFLUSH2		Flush the Slave Transmit ID2 FIFO. Writing a 1 to this bit flushes the slave transmit ID2 FIFO.	0x0	W
9	SFLUSH1		Flush the Slave Transmit ID1 FIFO. Writing a 1 to this bit flushes the slave transmit ID1 FIFO.	0x0	W
8	SFLUSH0		Flush the Slave Transmit ID0 FIFO. Writing a 1 to this bit flushes the slave transmit ID0 FIFO.	0x0	W
[7:6]	STX3FSTA	00 01 10 11	Slave Transmit ID3 FIFO Status. The status is a count of the number of bytes in a FIFO. FIFO empty. 1 byte in the FIFO. 2 bytes in the FIFO. Reserved.	0x0	R
[5:4]	STX2FSTA	00 01 10 11	Slave Transmit ID2 FIFO Status. The status is a count of the number of bytes in a FIFO. FIFO empty. 1 byte in the FIFO. 2 bytes in the FIFO. Reserved.	0x0	R
[3:2]	STX1FSTA	00 01 10 11	Slave Transmit ID1 FIFO Status. The status is a count of the number of bytes in a FIFO. FIFO empty. 1 byte in the FIFO. 2 bytes in the FIFO. Reserved.	0x0	R
[1:0]	STX0FSTA	00 01 10 11	Slave Transmit ID0 FIFO Status. The status is a count of the number of bytes in a FIFO. FIFO empty. 1 byte in the FIFO. 2 bytes in the FIFO. Reserved.	0x0	R

Slave 10-Bit Address, First Byte Register

Address: 0x40020860, Reset: 0x0000, Name: SLVADDR1

Table 149. Bit Descriptions for SLVADDR1

Bits	Bit Name	Settings	Description	Reset	Access
[15:8]	RESERVED		Reserved.	0x0	R
[7:0]	SLV_ADR1		Slave 10-Bit Address, First Byte.	0x0	R/W

I²C SERIAL INTERFACES**Slave 10-Bit Address, Second Byte Register**

Address: 0x40020864, Reset: 0x0000, Name: SLVADDR2

Table 150. Bit Descriptions for SLVADDR2

Bits	Bit Name	Settings	Description	Reset	Access
[15:8]	RESERVED		Reserved.	0x0	R
[7:0]	SLV_ADR2		Slave 10-Bit Address, Second Byte.	0x0	R/W

Slave I²C Status/IRQ 2 Register

Address: 0x40020868, Reset: 0x0000, Name: SSTAT2

Table 151. Bit Descriptions for SSTAT2

Bits	Bit Name	Settings	Description	Reset	Access
[15:3]	RESERVED		Reserved.	0x0	R
2	RW_DIRECTION		Slave I ² C R/W Direction. 1 Set 1 during a read. 0 Cleared to 0 during a write.	0x0	R
1	ADDR_ACK_IRQ		Slave Address Acknowledge Interrupt State. This bit is cleared by writing 1 to it.	0x0	R/W
0	SSCL_IRQ		Stretch Interrupt State. When SSCL_IRQ_IEN is set to 1 in the ASTRETCHSCL register, this bit can generate an interrupt.	0x0	R

UART SERIAL INTERFACE

UART FEATURES

The ADuCM410 and ADuCM420 feature two industry-standard 16450 and 16550 UART peripherals with support for DMA.

UART OVERVIEW

The UART peripherals are full duplex UARTs, compatible with the industry-standard 16450 and 16550. The UARTs are responsible for converting data between serial and parallel formats. The serial communication follows an asynchronous protocol, supporting various word lengths, stop bits, and parity generation options.

This UARTs also contain interrupt handling hardware. The UARTs feature a fractional divider that facilitates high accuracy baud rate generation.

Interrupts can be generated from several unique events, such as a full or empty data buffer, transfer error detection, and break detection.

UART OPERATION

Serial Communications

An asynchronous serial communication protocol is followed with these options:

- ▶ 5 data bits to 8 data bits
- ▶ 1, 2, or 1½ stop bits
- ▶ Even or odd parity, or none
- ▶ Programmable over sample rate by 4, 8, 16, or 32 when the OSR bits are equal to 0, 1, 2, 3 (decimal) in the LCR2 register.
- ▶ The baud rate is as follows:

$$\text{Baud Rate} = (PCLK1 / ((M + N/2048) \times 2^{LCR2_OSR + 2} \times DIV)) \quad (18)$$

where:

PCLK1 is the divided root clock as configured via CLKCON1, Bits[8:6].

M = 1 to 3. See [Table 164](#).

N = 0 to 2047. See [Table 164](#).

DIV = 1 to 65,536.

LCR2_OSR is the oversample rate via the OSR bits in the LCR2 register (0 to 3 decimal).

All data-words require a start bit and at least one stop bit, which creates a range from 7 bits to 12 bits for each word. Transmit operation is initiated by writing to the transmit buffer register (TX). After a synchronization delay, the data is moved to the internal transmit shift register (TSR), where it is shifted out at a baud (bit) rate equal to the following with the start, stop, and parity bits appended as required:

$$PCLK1 \div (2^{LCR2_OSR + 2} \times DIV) \div (M + (N \div 2048)) \quad (19)$$

All data-words begin with a low going start bit. The transfer of the transmit buffer register to the transmit shift register causes the transmit register empty status bit (THRE) to be set. [Table 152](#) shows an example of baud rates assuming *PCLK1* = 20 MHz.

Receive operation uses the same data format as the transmit configuration, except for the number of stop bits, which is always one. After detection of the start bit, the received word is shifted into the receive shift register. After the appropriate number of bits (including stop bits) are received, the receive shift register is transferred to the receive buffer register, after the appropriate synchronization delay, and the receive buffer register full status flag (STA) is updated.

A sampling clock equal to $2^{LCR2_OSR + 2}$ times the baud rate is used to sample the data as close to the midpoint of the bit as possible. A receive filter is also present that removes outlier pulses of less than two times the sampling clock period.

Note that data is transmitted and received least significant bit first, that is, Bit 0 of the transmit shift register.

While the UART implementation supports modem control signals, only serial transmit and receive functionality is supported.

The following modem inputs in the UART MSR register are tied high internally: DCD, RI, DSR, and CTS.

The following modem outputs in the UART MCR register are not connected: RTS, DTR, OUT1, and OUT2.

UART SERIAL INTERFACE

Baud Rate Generator

To bypass the fractional divider FBR, Bit 15 must be 0, resulting in

$$\text{Baud Rate} = \text{PCLK1} / (2^{\text{LCR2_OSR} + 2} \times \text{DIV}) \quad (20)$$

To estimate the DIVN and DIVM values, the fractional baud rate generator is used for fine-tuning of the baud rate if the integer, DIV, adds too much error to the rate. Setting DIV to 0 disables the UART logic.

Table 152. Baud Rate Examples Based on a 20 MHz PCLK1

Baud Rates	OSR	DIV	DIVM	DIVN	Actual Rate	Error (%)
9600	3	64	1	35	9599.25	-0.0078
19,200	3	31	1	102	19203	+0.0050
38,400	3	15	1	174	38398	-0.0050
57,600	3	9	1	421	57603	+0.0100
115,200	3	4	1	729	115232	+0.0100
230,400	3	1	2	1459	230413	+0.0100
460,800	3	1	1	923	460866	+0.0100

Programmed Input/Output Mode

In programmed input/output mode, the software is responsible for moving data to and from the UART. This movement is typically accomplished by interrupt service routines that respond to the transmit and receive interrupts by either reading or writing data as appropriate. This mode puts certain constraints on the software itself in that the software must respond within a certain time to prevent overflow errors from occurring in the receive channel.

Polling the status flag is processor intensive and not typically used unless the system can tolerate the overhead. Interrupts can be disabled using the IEN register.

Do not write to the transmit buffer register when it is not empty or read the receive buffer register when it is not full because doing so produces an incorrect result. In the former case, the transmit buffer register is overwritten by the new word and the previous word is never transmitted. In the latter case, the previously received word is read again. Both errors must be avoided in software by correctly using either interrupts or status register polling. These errors are not detected in hardware.

Power-Down Modes

When powering down the chip into hibernate, the recommendation is to finish all the on-going UART transfers and then enter hibernate mode. However, if the user decides to hibernate as early as possible (current data transfers are ignored), disable the UART by clearing the DIV register before entering hibernate mode.

If hibernate mode is selected while a UART transfer is ongoing, the transfer does not continue upon returning from hibernate. All the intermediate data, states, and status logic in UART are cleared.

After hibernation, the UART can be enabled by setting the proper DIV register settings if previously cleared. In addition, if DMA mode is needed, IEN, Bits[5:4] must be configured.

To have a safe wake-up, the UART block must be either disabled by clearing the DIV register before entering hibernate mode, or left enabled before entering hibernate mode. Apply a long break (>10 μ s), at least 1 frame period longer than the system power-up time) to the device before any following UART transactions, so that the UART can see the break condition after waking up.

Interrupts

The UART peripherals have one interrupt output each to the interrupt controller for both receive and transmit interrupts. The IIR register must be read by the software to determine the cause of the interrupt. Note that in DMA mode, the break interrupt is not available. When receiving in input/output mode, the interrupt is generated for the following cases:

- ▶ Receive full.
- ▶ Receive overrun error.

UART SERIAL INTERFACE

- ▶ Receive parity error.
- ▶ Receive framing error.
- ▶ Receive FIFO timeout if FIFO (16550) is enabled.
- ▶ Break interrupt (SINx held low).
- ▶ Modem status interrupt (changes to DCD, RI, DSR, or CTS).
- ▶ Transmit empty.

Buffer Requirements

The UARTs are double buffered (holding register and shift register).

DMA Mode

In DMA mode, user code does not move data to and from the UART. DMA request signals going to the external DMA block indicate that the UART is ready to transmit or receive data. These DMA request signals can be disabled in the UART interrupt enable register, IEN.

FIFO Mode 16550

16-byte deep transmit FIFO and receive FIFOs are implemented for 16550 compatible mode. The FIFOs are disabled by default. When enabled in FCR, Bit 0, the internal FIFOs are activated, allowing 16 bytes (plus 3 bits of error data per byte in the receive FIFO) to be stored in both receive and transmit modes to minimize system overhead and maximize system efficiency.

The interrupt and/or DMA trigger level of the receive FIFOs is programmable via FCR, Bits[7:6]. The DMA request has programmable modes by the FCR register. DMA Mode 1 only works when the FIFO is enabled and works like burst mode.

Autobaud Rate Detection

The autobaud detection block is used for two UART devices to match baud rate automatically without presumptions. Enable the receiver device to detect mode before the common baud rate is configured.

ACR, Bit 0 must be enabled for the receiver device to work in autobaud detection mode. A 20-bit counter logic counts cycle numbers from the programmed rising or falling edge to another rising or falling edge. An interrupt is generated when the number of expected edges is reached. The counter can possibly overflow and generate a timeout interrupt, for example, a continuous break condition or no expected edges.

Disable autobaud detection to clear the internal counter, and reenables autobaud detection for another run if needed.

The autobaud detection result can be calculated via the UART baud rate configuration as follows from

$$\text{Counted Bits} \times 2^{\text{OSR} + 2} \times \text{DIV} \times (\text{DIVM} + \text{DIVN} \div 2048) = \text{CNT}, \text{ Bits}[19:0] \quad (21)$$

where *Counted Bits* is the effective bit number between the active starting edge and the ending edge. *Counted Bits* is determined by application code upon the selected edges and the character used for autobaud detection.

If $\text{CNT} < 8 \times \text{Counted Bits}$, $\text{OSR} = 0$, $\text{DIV} = 1$, then

$$\text{DIVN} = 512 \times \text{CNT} \div \text{Counted Bits} - 2048 \quad (22)$$

If $\text{CNT} < 16 \times \text{Counted Bits}$, $\text{OSR} = 1$, $\text{DIV} = 1$, then

$$\text{DIVN} = 256 \times \text{CNT} \div \text{Counted Bits} - 2048 \quad (23)$$

If $\text{CNT} < 32 \times \text{Counted Bits}$, $\text{OSR} = 2$, $\text{DIV} = 1$, then

$$\text{DIVN} = 128 \times \text{CNT} \div \text{Counted Bits} - 2048 \quad (24)$$

If $\text{CNT} \geq 32 \times \text{Counted Bits}$, $\text{OSR} = 3$, and if CNT is exactly divided by $(32 \times \text{Counted Bits})$, $\text{DIV} = \text{CNT} \div 32 \div \text{Counted Bits}$, then

$$\text{DIVN} = 64 \times \text{CNT} \div \text{DIV} \div \text{Counted Bits} - 2048 \quad (25)$$

To reduce truncation errors, always set DIVM to 1. Set DIV to the nearest power of 2 if not exactly divided.

UART SERIAL INTERFACE

RS485 Half-Duplex Mode

To support RS485 multiplexing of the transmit and receiver as half duplex, configure the RSC register so that the transmit driver is enabled when SOUTx is asserted.

Receive Line Inversion

For specific applications like a UART communication through the optical link, it is possible to have a receive line working at the opposite level, that is, idling at a low level. CTL, Bit 4 can be used to invert the receive line for this purpose.

Do not use the receive line inversion together with the RS485 application.

CTL, Bit 4 must be configured first before the UART and autobaud detection are enabled.

Clock Gating

The clock driving UART logic is automatically gated off when idling and not accessed. The automatic clock gating can be disabled through CTL, Bit 1.

REGISTER SUMMARY: UART0, UART1

Table 153. UART Register Summary

Address	Name	Description	Reset	RW
UART0				
0x40020000	RX or TX	Receive Buffer or Transmit Buffer.	0x0000	R
0x40020004	IEN	Interrupt Enable.	0x0000	R/W
0x40020008	IIR	Interrupt ID.	0x0001	R
0x4002000C	LCR	Line Control.	0x0000	R/W
0x40020010	MCR	Modem Control	0x0000	R/W
0x40020014	LSR	Line Status.	0x0060	R
0x40020018	MSR	Modem Status.	0x00XX	R
0x4002001C	SCR	Scratch Buffer.	0x0000	R/W
0x40020020	FCR	FIFO Control.	0x0000	R/W
0x40020024	FBR	Fractional Baud Rate.	0x0000	R/W
0x40020028	DIV	Baud Rate Divider.	0x0000	R/W
0x4002002C	LCR2	Second Line Control.	0x0002	R/W
0x40020030	CTL	UART Control.	0x0100	R/W
0x40020034	RFC	Receive FIFO Byte Count.	0x0000	R
0x40020038	TFC	Transmit FIFO Byte Count.	0x0000	R
0x4002003C	RSC	RS485 Half-Duplex Control.	0x0000	R/W
0x40020040	ACR	Autobaud Control.	0x0000	R/W
0x40020044	ASRL	Autobaud Status (Low).	0x0000	R
0x40020048	ASRH	Autobaud Status (High).	0x0000	R
UART1				
0x40020400	RX or TX	Receive Buffer or Transmit Buffer.	0x0000	R
0x40020404	IEN	Interrupt Enable.	0x0000	R/W
0x40020408	IIR	Interrupt ID.	0x0001	R
0x4002040C	LCR	Line Control.	0x0000	R/W
0x40020410	MCR	Modem Control.	0x0000	R/W
0x40020414	LSR	Line Status.	0x0060	R
0x40020418	MSR	Modem Status.	0x00XX	R
0x4002041C	SCR	Scratch Buffer.	0x0000	R/W
0x40020420	FCR	FIFO Control.	0x0000	R/W
0x40020424	FBR	Fractional Baud Rate.	0x0000	R/W
0x40020428	DIV	Baud rate Divider.	0x0000	R/W

UART SERIAL INTERFACE

Table 153. UART Register Summary (Continued)

Address	Name	Description	Reset	RW
0x4002042C	LCR2	Second Line Control.	0x0002	R/W
0x40020430	CTL	UART Control.	0x0100	R/W
0x40020434	RFC	Receive FIFO Byte Count.	0x0000	R
0x40020438	TFC	Transmit FIFO Byte Count.	0x0000	R
0x4002043C	RSC	RS485 Half-Duplex Control.	0x0000	R/W
0x40020440	ACR	Autobaud Control.	0x0000	R/W
0x40020444	ASRL	Autobaud Status (Low).	0x0000	R
0x40020448	ASRH	Autobaud Status (High).	0x0000	R

REGISTER DETAILS: UART0, UART1

Receive Buffer Register or Transmit Buffer Register

Address: 0x40020000, Reset: 0x0000, Name: RX or TX (UART0)

Address: 0x40020400, Reset: 0x0000, Name: RX or TX (UART1)

Table 154. Bit Descriptions for RX

Bits	Bit Name	Settings	Description	Reset	Access
[15:8]	RESERVED		Reserved.	0x0	R
[7:0]	RBR		Receive Buffer Register.	0x0	R

Table 155. Bit Descriptions for TX

Bits	Bit Name	Settings	Description	Reset	Access
[15:8]	RESERVED		Reserved.	0x0	R
[7:0]	TBR		Transmit Buffer Register.	0x0	R

Interrupt Enable Register

Address: 0x40020004, Reset: 0x0000, Name: IE (UART0)

Address: 0x40020404, Reset: 0x0000, Name: IE (UART1)

Table 156. Bit Descriptions for IEN

Bits	Bit Name	Settings	Description	Reset	Access
[15:6]	RESERVED		Reserved.	0x0	R
5	EDMAR	0x0 0x1	DMA Requests in Receive Mode. DMA Requests Disabled. DMA Requests Enabled.	0x0	R/W
4	EDMAT	0x0 0x1	DMA Requests in Transmit Mode. DMA Requests are Disabled. DMA Requests are Enabled.	0x0	R/W
3	EDSSI	0x0 0x1	Modem Status Interrupt. Interrupt is generated when any of MSR, Bits[3:0] are set. Interrupt Disabled. Interrupt Enabled.	0x0	R/W
2	ELSI	0x0 0x1	Receive Status Interrupt. Interrupt Disabled. Interrupt Enabled.	0x0	R/W
1	ETBEI	0x0 0x1	Transmit Buffer Empty Interrupt. Interrupt Disabled. Interrupt Enabled.	0x0	R/W
0	ERBFI	0x0	Receive Buffer Full Interrupt. Interrupt Disabled.	0x0	R/W

UART SERIAL INTERFACE

Table 156. Bit Descriptions for IEN (Continued)

Bits	Bit Name	Settings	Description	Reset	Access
		0x1	Interrupt Enabled.		

Interrupt ID Register

Address: 0x40020008, Reset: 0x0001, Name: IIR (UART0)

Address: 0x40020408, Reset: 0x0001, Name: IIR (UART1)

Table 157. Bit Descriptions for IIR

Bits	Bit Name	Settings	Description	Reset	Access
[15:8]	RESERVED		Reserved.	0x0	R
[7:6]	FEND	0x0 0x3	FIFO Enabled. FIFO Not Enabled, 16450 Mode. FIFO Enabled, 16550 Mode. All other combinations are reserved.	0x0	R
[5:4]	RESERVED		Reserved.	0x0	R
[3:1]	STAT	0x0 0x1 0x2 0x6 0x3	Interrupt Status. When IIR, Bit 0 is low (active low), this indicates an interrupt and the following decoding of IIR, Bits[3:1] is used. Modem Status Interrupt (Read MSR Register to Clear). Transmit Buffer Empty Interrupt (Write to Tx Register or Read IIR Register to Clear). Receive Buffer Full Interrupt (Read Rx Register to Clear). Receive FIFO Timeout Interrupt (Read Rx Register to Clear). Receive Line Status Interrupt (Read LSR Register to Clear).	0x0	RC
0	NIRQ	0x0 0x1	Interrupt Flag. Interrupt Occurred. Source of interrupt indicated in the STAT bits. No Interrupt Occurred.	0x1	RS

Line Control Register

Address: 0x4002000C, Reset: 0x0000, Name: LCR (UART0)

Address: 0x4002040C, Reset: 0x0000, Name: LCR (UART1)

Table 158. Bit Descriptions for LCR

Bits	Bit Name	Settings	Description	Reset	Access
[15:7]	RESERVED		Reserved.	0x0	R
6	BRK	1 0	Set Break. Force TxD to 0. Normal TxD operation.	0x0	R/W
5	SP	0x0 0x1	Stick parity. Used to force parity to defined values. When set, the parity is based on the following bit settings: When EPS = 1 and PEN = 1, the parity is forced to 0. When EPS = 0 and PEN = 1, the parity is forced to 1. When EPS = X (don't care) and PEN = 0, no parity is transmitted. Parity is not forced based on EPS and PEN bits. Parity forced based on EPS and PEN bits.	0x0	R/W
4	EPS	0x0 0x1	Parity Select. This bit only has meaning if parity is enabled (PEN set). Odd parity is transmitted and checked. Even parity is transmitted and checked.	0x0	R/W
3	PEN		Parity Enable. Used to control the parity bit transmitted and checked. The value transmitted and the value checked are based on the settings of EPS and SP bit.	0x0	R/W

UART SERIAL INTERFACE

Table 158. Bit Descriptions for LCR (Continued)

Bits	Bit Name	Settings	Description	Reset	Access
		0x0	Parity is not transmitted or checked.		
		0x1	Parity is transmitted and checked.		
2	STOPPED		Stop Bit. Used to control the number of stop bits transmitted. In all cases, only the first stop bit is evaluated on data received.	0x0	R/W
		0x0	Send 1 stop bit regardless of the word length select bit (WLS).		
		0x1	Send several stop bits based on the word length. Transmit 1.5 stop bits if the word length is 5 bits (WLS = 0x0), or 2 stop bits if the word length is 6 (WLS = 0x1), 7 (WLS = 0x2), or 8 bits (WLS = 0x3).		
[1:0]	WLS		Word Length Select. Selects the number of bits per transmission.	0x0	R/W
		0x0	5 bits.		
		0x1	6 bits.		
		0x2	7 bits.		
		0x3	8 bits.		

Modem Control Register

Address: 0x40020010, Reset: 0x0000, Name: MCR (UART0)

Address: 0x40020410, Reset: 0x0000, Name: MCR (UART1)

Table 159. Bit Descriptions for MCR

Bits	Bit Name	Settings	Description	Reset	Access
[15:5]	RESERVED		Reserved.	0x0	R
4	LOOPBACK		Loopback Mode. In loopback mode, the SOUTx signal is forced high. The modem signals are also directly connected to the status inputs (RTS to CTS, DTR to DSR, OUT1 to RI, and OUT2 to DCD).	0x0	R/W
		0x0	Normal Operation, Loopback Disabled.		
		0x1	Loopback Enabled.		
3	OUT2		Output 2. Not connected to an external pin.	0x0	R/W
		0x0	Force OUT2 to a Logic 1.		
		0x1	Force OUT2 to a Logic 0.		
2	OUT1		Output 1. Not connected to an external pin.	0x0	R/W
		0x0	Force OUT1 to a Logic 1.		
		0x1	Force OUT1 to a Logic 0.		
1	RTS		Request to Send. Not connected to an external pin.	0x0	R/W
		0x0	Force RTS to a Logic 1.		
		0x1	Force RTS to a Logic 0.		
0	DTR		Data Terminal Ready. Not connected to an external pin.	0x0	R/W
		0x0	Force DTR to a Logic 1.		
		0x1	Force DTR to a Logic 0.		

Line Status Register

Address: 0x40020014, Reset: 0x0060, Name: LSR (UART0)

Address: 0x40020414, Reset: 0x0060, Name: LSR (UART1)

Table 160. Bit Descriptions for LSR

Bits	Bit Name	Settings	Description	Reset	Access
[15:8]	RESERVED		Reserved.	0x0	R
7	FIFOERR		FIFO Error. Data byte in RX FIFO has parity error, frame error, or break indication. Can only be used in 16550 mode. Read to clear if no more error in RX FIFO.	0x0	RC
6	TEMT		Transmit and Shift Register Empty Status.	0x1	R
		0x0	TX register has been written to and contains data to be transmitted. Take care not to overwrite its value.		

UART SERIAL INTERFACE

Table 160. Bit Descriptions for LSR (Continued)

Bits	Bit Name	Settings	Description	Reset	Access
		0x1	TX register is empty, and it is safe to write new data to the TX register. The previous data may not have been transmitted yet and can still be present in the shift register.		
5	THRE		Transmit Register Empty.	0x1	R
		0x0	TX register has been written to and contains data to be transmitted. Take care not to overwrite its value.		
		0x1	TX register is empty, and it is safe to write new data to the TX register. The previous data may not have been transmitted yet and can still be present in the shift register.		
4	BI		Break Indicator. If set, this bit clears after LSR is read.	0x0	RC
		0x0	SINx was not detected to be longer than the maximum word length.		
		0x1	SINx was held low for more than the maximum word length.		
3	FE		Framing Error. If set, this bit clears after LSR is read.	0x0	RC
		0x0	No invalid stop bit was detected.		
		0x1	An invalid stop bit was detected on a received word.		
2	PE		Parity Error. If set, this bit clears after LSR is read.	0x0	RC
		0x0	No parity error was detected.		
		0x1	A parity error occurred on a received word.		
1	OE		Overrun Error. If set, this bit clears after LSR is read.	0x0	RC
		0x0	Receive data has not been overwritten.		
		0x1	Receive data was overwritten by new data before RX register was read.		
0	DR		Data Ready. This bit is cleared only by reading RX.	0x0	RC
		0x0	RX register does not contain new receive data.		
		0x1	RX register contains receive data that must be read.		

Modem Status Register

Address: 0x40020018, Reset: 0x00XX, Name: MSR (UART0)

Address: 0x40020418, Reset: 0x00XX, Name: MSR (UART1)

Table 161. Bit Descriptions for MSR

Bits	Bit Name	Settings	Description	Reset	Access
[15:8]	RESERVED		Reserved.	0x0	R
7	DCD		Data Carrier Detect. Not connected to an external pin.	0xX	R
		0x0	DCD is Currently Logic High.		
		0x1	DCD is Currently Logic Low.		
6	RI		Ring Indicator. Not connected to an external pin.	0xX	R
		0x0	RI is Currently Logic High.		
		0x1	RI is Currently Logic Low.		
5	DSR		Data Set Ready. Not connected to an external pin.	0xX	R
		0x0	DSR is Currently Logic High.		
		0x1	DSR is Currently Logic Low.		
4	CTS		Clear to Send. Not connected to an external pin.	0xX	R
		0x0	CTS is Currently Logic High.		
		0x1	CTS is Currently Logic Low.		
3	DDCD		Delta Data Carrier Detect. If set, this bit aut clears after MSR is read.	0xX	R
		0x0	Data Carrier Detect Bit Has Not Changed State Since MSR Register Was Last Read.		
		0x1	Data Carrier Detect Bit Changed State Since MSR Register Last Read.		
2	TERI		Trailing Edge RI. If set, this bit clears after MSR is read.	0xX	R
		0x0	Ring Indicator Bit Has Not Changed from 0 to 1 Since MSR Register Last Read.		
		0x1	Ring Indicator Bit Changed from 0 to 1 Since MSR Register Last Read.		
1	DDSR		Delta DSR. If set, this bit clears after MSR is read.	0xX	R

UART SERIAL INTERFACE

Table 161. Bit Descriptions for MSR (Continued)

Bits	Bit Name	Settings	Description	Reset	Access
		0x0	Data Set Ready Bit Has Not Changed State Since MSR Register Was Last Read.		
		0x1	Data Set Ready Bit Changed State Since MSR Register Last Read.		
0	DCTS		Delta Clear to Send. If set, this bit autoclears after MSR is read.	0xX	R
		0x0	Clear to Send Bit Has Not Changed State Since MSR Register Was Last Read.		
		0x1	Clear to Send Bit Changed State Since MSR Register Last Read.		

Scratch Buffer Register

Address: 0x4002001C, Reset: 0x0000, Name: SCR (UART0)

Address: 0x4002041C, Reset: 0x0000, Name: SCR (UART1)

Table 162. Bit Descriptions for SCR

Bits	Bit Name	Settings	Description	Reset	Access
[15:8]	RESERVED		Reserved.	0x0	R
[7:0]	SCR		Scratch. The scratch register is an 8-bit register used to store intermediate results. The value contained in the scratch register does not affect UART functionality or performance. Only 8 bits of this register are implemented. Bit 15 to Bit 8 are read only and always return 0x00 when read. Writable with any value from 0 to 255. A read returns the last value written.	0x0	R/W

FIFO Control Register

Address: 0x40020020, Reset: 0x0000, Name: FCR (UART0)

Address: 0x40020420, Reset: 0x0000, Name: FCR (UART1)

Table 163. Bit Descriptions for FCR

Bits	Bit Name	Settings	Description	Reset	Access
[15:8]	RESERVED		Reserved.	0x0	R
[7:6]	RFTRIG		Rx FIFO Trigger Level.	0x0	R/W
		0x0	1 Byte to Trigger Rx Interrupt.		
		0x1	4 Bytes to Trigger Rx Interrupt.		
		0x2	8 Bytes to Trigger Rx Interrupt.		
		0x3	14 Bytes to Trigger Rx Interrupt.		
[5:4]	RESERVED		Reserved.	0x0	R
3	FDAMAMD		FIFO DMA Mode.	0x0	R/W
		0x0	In DMA Mode 0, the Rx DMA request is asserted whenever there is data in the Rx register or the Rx FIFO and deasserted whenever the Rx FIFO is empty. The Tx DMA request is asserted whenever the Tx register or Tx FIFO is empty and deasserted whenever data is written.		
		0x1	In DMA Mode 1, Rx DMA request is asserted whenever the Rx FIFO trigger level or timeout reached and deasserted when the Rx FIFO is empty. The Tx DMA request is asserted whenever the Tx FIFO is empty and deasserted when the Tx FIFO is full.		
2	TFCLR		Clear Tx FIFO.	0x0	W
		1	Set to 1 to clear the Tx FIFO.		
1	RFCLR		Clear Rx FIFO.	0x0	W
		1	Set to 1 to clear the Rx FIFO.		
0	FIFOEN		FIFO Enable to Work in 16550 Mode.	0x0	R/W
		0x0	Disable 16550 Mode.		
		0x1	Enable 16550 Mode.		

UART SERIAL INTERFACE

Fractional Baud Rate Register

Address: 0x40020024, Reset: 0x0000 Name: UART0

Address: 0x40020424, Reset: 0x0000 Name: UART1

Name: FBR

Table 164. Bit Descriptions for FBR

Bits	Bit Name	Settings	Description	Reset	Access
15	FBEN		Fractional Baud Rate Generator Enable. The generating of fractional baud rate can be described by the following formula and the final baud rate of UART operation is calculated as Baud Rate = $(PCLK1 / ((M + N/2048) \times 2^{LCR2_OSR + 2} \times DIV))$.	0x0	R/W
[14:13]	RESERVED		Reserved.	0x0	R
[12:11]	DIVM		Fractional Baud Rate M Divide Bit 1 to Bit 3. This bit must not be 0 when fractional baud rate is enabled.	0x0	R/W
[10:0]	DIVN		Fractional Baud Rate N Divide Bit 0 to Bit 2047.	0x0	R/W

Baud Rate Divider Register

Address: 0x40020028, Reset: 0x0000, Name: DIV (UART0)

Address: 0x40020428, Reset: 0x0000, Name: DIV (UART1)

Internal UART baud generation counters are restarted whenever the DIV register is accessed by writing, regardless of whether the value is the same or different.

Table 165. Bit Descriptions for DIV

Bits	Bit Name	Settings	Description	Reset	Access
[15:0]	DIV		Baud Rate Divider. The range of allowed DIV values is from 1 to 65,535. If set to 0, UART logic disables.	0x0	R/W

Second Line Control Register

Address: 0x4002002C, Reset: 0x0002, Name: LCR2 (UART0)

Address: 0x4002042C, Reset: 0x0002, Name: LCR2 (UART1)

Table 166. Bit Descriptions for LCR2

Bits	Bit Name	Settings	Description	Reset	Access
[15:2]	RESERVED		Reserved.	0x0	R
[1:0]	OSR		Oversample Rate. 0x0 Oversample by 4. 0x1 Oversample by 8. 0x2 Oversample by 16. 0x3 Oversample by 32.	0x2	R/W

UART Control Register

Address: 0x40020030, Reset: 0x0100, Name: CTL (UART0)

Address: 0x40020430, Reset: 0x0100, Name: CTL (UART1)

Table 167. Bit Descriptions for CTL

Bits	Bit Name	Settings	Description	Reset	Access
[15:8]	REV		UART Revision ID.	0x1	R
[7:5]	RESERVED		Reserved.	0x0	R
4	RXINV		Invert Receiver Line.	0x0	R/W

UART SERIAL INTERFACE

Table 167. Bit Descriptions for CTL (Continued)

Bits	Bit Name	Settings	Description	Reset	Access
		0x0	Do not Invert Receiver Line (Idling High).		
		0x1	Invert Receiver Line (Idling Low).		
[3:0]	RESERVED		Reserved.	0x0	R/W

Receive FIFO Byte Count Register

Address: 0x40020034, Reset: 0x0100, Name: RFC (UART0)

Address: 0x40020434, Reset: 0x0100, Name: RFC (UART1)

Table 168. Bit Descriptions for RFC

Bits	Bit Name	Settings	Description	Reset	Access
[15:5]	RESERVED		Reserved.	0x0	R
[4:0]	RFC		Current number of bytes in the Rx FIFO.	0x0	R

Transmit FIFO Byte Count Register

Address: 0x40020038, Reset: 0x0000, Name: TFC (UART0)

Address: 0x40020438, Reset: 0x0000, Name: TFC (UART1)

Table 169. Bit Descriptions for TFC

Bits	Bit Name	Settings	Description	Reset	Access
[15:5]	RESERVED		Reserved.	0x0	R
[4:0]	TFC		Current number of bytes in the Tx FIFO.	0x0	R

RS485 Half-Duplex Control Register

Address: 0x4002003C, Reset: 0x0000, Name: RSC (UART0)

Address: 0x4002043C, Reset: 0x0000, Name: RSC (UART1)

Table 170. Bit Descriptions for RSC

Bits	Bit Name	Settings	Description	Reset	Access
[15:4]	RESERVED		Reserved.	0x0	R
3	DISTX		Set to 1 to hold off Tx when receiving.	0x0	R/W
2	DISRX		Set to 1 to disable Rx when transmitting.	0x0	R/W
1	OENSP		SOUTx Deassert Before Full Stop Bit.	0x0	R/W
		0x0	SOUTx Deassert Same Time as Full Stop Bit.		
		0x1	SOUTx Deassert Half Bit Earlier Than Full Stop Bit.		
0	OENP		SOUTx Polarity.	0x0	R/W
		0x0	Active High.		
		0x1	Active Low.		

Autobaud Control Register

Address: 0x40020040, Reset: 0x0000, Name: ACR (UART0)

Address: 0x40020440, Reset: 0x0000, Name: ACR (UART1)

Table 171. Bit Descriptions for ACR

Bits	Bit Name	Settings	Description	Reset	Access
[15:12]	RESERVED		Reserved.	0x0	R
[11:8]	EEC		Ending Edge Count.	0x0	R/W

UART SERIAL INTERFACE

Table 171. Bit Descriptions for ACR (Continued)

Bits	Bit Name	Settings	Description	Reset	Access
		0x0	First Edge.		
		0x1	Second Edge.		
		0x2	Third Edge.		
		0x3	Fourth Edge.		
		0x4	Fifth Edge.		
		0x5	Sixth Edge.		
		0x6	Seventh Edge.		
		0x7	Eighth Edge.		
		0x8	Ninth Edge.		
7	RESERVED		Reserved.	0x0	R
[6:4]	SEC		Starting Edge Count.	0x0	R/W
		0x0	First Edge (Always the Falling Edge of Start Bit).		
		0x1	Second Edge.		
		0x2	Third Edge.		
		0x3	Fourth Edge.		
		0x4	Fifth Edge.		
		0x5	Sixth Edge.		
		0x6	Seventh Edge.		
		0x7	Eighth Edge.		
3	RESERVED		Reserved.	0x0	R
2	TOIEN		Timeout Interrupt.	0x0	R/W
		0x0	Disable Enable Timeout.		
		0x1	Enable Timeout.		
1	DNIEEN		Done Interrupt.	0x0	R/W
		0x0	Disable Done Interrupt.		
		0x1	Enable Done Interrupt.		
0	ABE		Autobaud Rate Detection Bit.	0x0	R/W
		0x0	Disable Autobaud Rate Detection.		
		0x1	Enable Autobaud Rate Detection		

Autobaud Status (Low) Register

Address: 0x40020044, Reset: 0x0000, Name: ASRL (UART0)

Address: 0x40020444, Reset: 0x0000, Name: ASRL (UART1)

Table 172. Bit Descriptions for ASRL

Bits	Bit Name	Settings	Description	Reset	Access
[15:4]	CNT[11:0]		Autobaud Counter Value	0x0	R
3	NEETO		Timed Out Due to No Valid Ending Edge Found	0x0	RC
2	NSETO		Timed Out Due to No Valid Start Edge Found	0x0	RC
1	BRKTO		Timed Out Due to Long Time Break Condition	0x0	RC
0	DONE		Autobaud Rate Detection Complete	0x0	RC

UART SERIAL INTERFACE**Autobaud Status (High) Register**

Address: 0x40020048, Reset: 0x0000 Name: ASRH (UART0)

Address: 0x40020448, Reset: 0x0000 Name: ASRH (UART1)

Table 173. Bit Descriptions for ASRH

Bits	Bit Name	Settings	Description	Reset	Access
[15:8]	RESERVED		Reserved.	0x0	R
[7:0]	CNT[19:12]		Autobaud Counter Value.	0x0	R

SERIAL PERIPHERAL INTERFACES

SPI FEATURES

The ADuCM410 and ADuCM420 integrate three complete hardware SPIs with the following standard SPI features:

- ▶ Master or slave mode
- ▶ Transfer and interrupt mode
- ▶ Continuous transfer mode
- ▶ Serial clock phase and polarity flexibility
- ▶ Transmit and receive FIFOs
- ▶ Interrupt mode; interrupt after one, two, three, four, five, six, seven, or eight bytes
- ▶ LSB first transfer option
- ▶ Loopback mode
- ▶ Receive overflow mode and transmit underrun mode
- ▶ Wire-OR'ed output mode (open drain)
- ▶ Full duplex communications supported (simultaneous transmit/receive)
- ▶ \overline{CSx} software override support
- ▶ 3-pin SPI support for master or slave (single bidirectional data pin)

SPI OVERVIEW

The ADuCM410 and ADuCM420 integrate three complete hardware serial peripheral interfaces. SPI is an industry-standard, synchronous serial interface that allows eight bits of data to be synchronously transmitted and simultaneously received, that is, full duplex. The three SPIs implemented on the ADuCM410 and ADuCM420 can operate to a maximum bit rate of 40 Mbps in both master and slave modes when the system clock is configured for 160 MHz. The maximum baud rate is HCLK/4.

The SPI blocks have an additional DMA feature. Each SPI block has two DMA channels that interface with a μ DMA controller of the Arm Cortex-M33 processor. One DMA channel is used for transmitting data, and the other is used for receiving data.

SPI OPERATION

The SPI port can be configured for master or slave operation and consists of four sets of signals: MISO_x, MOSI_x, SCLK_x, and \overline{CSx} (where x = 0, 1, or 2).

Note that the GPIOs used for SPI communication must be configured in SPI mode before enabling the SPI peripheral. The peripheral can be enabled by setting CTL, Bit 0 = 1.

Master Input, Slave Output (MISO_x)

MISO_x is configured as an input line in master mode and an output line in slave mode. The MISO_x line on the master (data in) must be connected to the MISO_x line in the slave device (data out). The data is transferred as byte wide (8-bit) serial data, MSB first.

Master Out, Slave Input (MOSI_x)

MOSI_x is configured as an output line in master mode and an input line in slave mode. The MOSI_x line on the master (data out) must be connected to the MOSI_x line in the slave device (data in). The data is transferred as byte-wide (8-bit) serial data, MSB first.

Serial Clock Input/Output (SCLK_x)

The master serial clock (SCLK_x) synchronizes the data being transmitted and received through the MOSI_x SCLK_x period. Therefore, a byte is transmitted or received after eight SCLK_x periods. SCLK_x is configured as an output in master mode and as an input in slave mode.

In master mode, the CTL register controls the polarity and phase of the clock, and the bit rate is defined in the DIV register as follows:

$$f_{SERIALCLOCK} = \frac{SPICLK}{2 \times (1 + SPI \times DIV \text{ Bits}[5:0])} \quad (26)$$

where *SPICLK* is the 160 MHz system clock divided by the factor set in the CLKCON1, Bits[2:0].

By reducing the clock rate to the SPI blocks, it is possible to reduce the power consumption of the SPI block.

SERIAL PERIPHERAL INTERFACES

The maximum SCLKx frequency allowed is 40 MHz.

In slave mode, the CTL register must be configured with the phase and polarity of the expected input clock. The slave accepts data from an external master up to 40 Mbps.

In both master and slave mode, data is transmitted on one edge of the SCLKx signal and sampled on the other. Therefore, it is important that the polarity and phase be configured the same for the master and slave devices.

Chip Select Input (\overline{CSx})

In SPI slave mode, a transfer is initiated by the assertion of \overline{CSx} , which is an active low input signal. The SPI port then transmits and receives 8-bit data until the transfer is concluded by pulling \overline{CSx} high. In slave mode, \overline{CSx} is always an input.

In SPI master mode, \overline{CSx} is an active low output signal. \overline{CSx} asserts itself automatically at the beginning of a transfer and deasserts itself upon completion.

SPI TRANSFER INITIATION

In master mode, the transfer and interrupt mode bit, TIM (CTL, Bit 6), determines the way an SPI serial transfer is initiated. If the TIM bit is set, a serial transfer is initiated after a write to the transmit FIFO. If the TIM bit is cleared, a serial transfer is initiated after a read of the receive FIFO. The receive FIFO must be read while the SPI interface is idle. A read during an active transfer does not initiate another transfer.

When the MASEN (CTL, Bit 1) and TIM (CTL, Bit 6) bits are set, the SPI simultaneously receives and transmits data when RDCTL, Bit 0 = 0. Therefore, during data transmission, the SPI is also receiving data and filling up the receive FIFO. If the data is not read from the receive FIFO, the overflow interrupt occurs when the FIFO starts to overflow. If the user does not want to read the receive data or receive overflow interrupts, RFLUSH (CTL, Bit 12) can be set and the receive data is not saved to the receive FIFO. Otherwise, to read some of the receive data but avoid an overflow condition, this interrupt can be disabled by clearing IEN, Bit 10. Similarly, when the user only wants to receive data and does not want to write data to the transmit FIFO, the transmit FIFO flush enable, TFLUSH (CTL, Bit 13) can be set to avoid receiving underflow interrupts from the transmit FIFO. Alternatively, to send the FIFO data but avoid underflow interrupts, clear Bit 9 in the EIN register.

Transmit Initiated Transfer

For transfers initiated by a write to the transmit FIFO, the SPI starts transmitting as soon as the first byte is written to the FIFO, irrespective of the configuration in IEN, Bits[2:0]. The first byte is immediately read from the FIFO, written to the transmit shift register, and the transfer commences.

If the continuous transfer enable bit (CTL, Bit 11) is set, the transfer continues until no valid data is available in the transmit FIFO. There is no stall period between transfers where \overline{CSx} is deasserted. \overline{CSx} is asserted and remains asserted for the duration of the transfer until the transmit FIFO is empty. Determining when the transfer stops does not depend on IEN, Bits[2:0]. The transfer stops when there is no valid data left in the FIFO. Conversely, the transfer continues while there is valid data in the FIFO.

If the continuous transfer enable bit (CTL, Bit 11) is cleared, each transfer consists of a single 8-bit serial transfer. If valid data exists in the transmit FIFO, a new transfer is initiated after a stall period where \overline{CSx} is deasserted.

Receive Initiated Transfer

Transfers initiated by a read of the receive FIFO depend on the number of bytes received in the FIFO. If IRQMODE is set to 7 and a read to the receive FIFO occurs, the SPI initiates an 8-byte transfer. If continuous mode is set, the eight bytes occur continuously with no deassertion of \overline{CSx} between bytes. If continuous mode is not set, the eight bytes occur with stall periods between transfers where \overline{CSx} is deasserted (pulled high). However, in continuous mode, if CNT, Bits[13:0] is greater than 0, \overline{CSx} is asserted for the entire frame duration. The SPI introduces stall periods by not clocking SCLKx until the FIFO space is available.

If continuous mode is not set, the eight bytes occur with stall periods between transfers where the chip select output is deasserted.

If SPI_IEN, Bits[2:0] = 0x6, a read of the receive FIFO initiates a 7-byte transfer.

If SPI_IEN, Bits[2:0] = 0x1, a read of the receive FIFO initiates a 2-byte transfer.

If SPI_IEN, Bits[2:0] = 0x0, a read of the receive FIFO initiates a 1-byte transfer.

A read of the receive FIFO while the SPI is receiving data does not initiate another transfer after the present transfer is complete.

SERIAL PERIPHERAL INTERFACES

In continuous mode, if CNT, Bits[13:0] > 0 and CNT, Bit 15 = 1, a read of the receive FIFO at the end of an SPI frame (to obtain the last set of bytes received) always initiates a new SPI frame. Therefore, to stop SPI transfers at any given frame, clear CNT, Bit 15 before reading the final set of receive-bytes.

The SPI transfer protocol diagrams (see Figure 20 and Figure 21) illustrate the data transfer protocol for the SPI and the effects of the CPHA and CPOL bits in the control register (CTL) on that protocol.

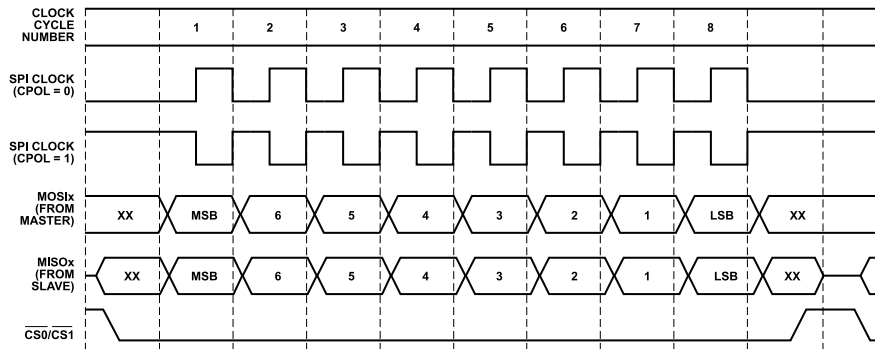

Figure 20. SPI Transfer Protocol, CPHA = 0

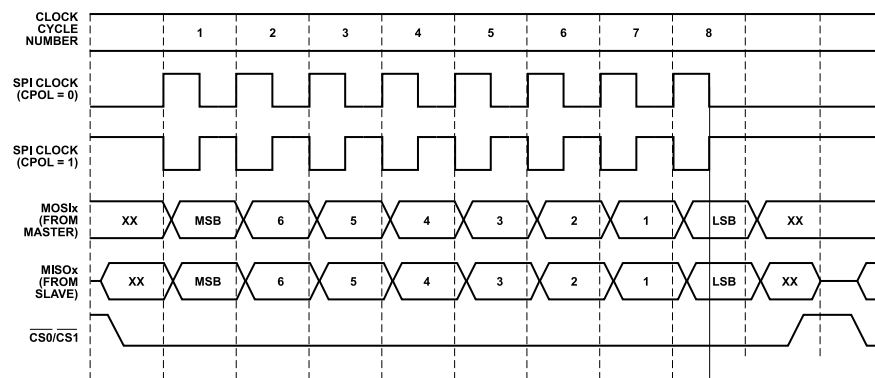

Figure 21. SPI Transfer Protocol, CPHA = 1

SPI Data Underrun and Overflow

If the transmit zeros enable bit, ZEN (CTL, Bit 7), is cleared, the last byte from the previous transmission is shifted out when a transfer is initiated with no valid data in the FIFO. If the ZEN bit = 1, 0s are transmitted when a transfer is initiated with no valid data in the FIFO.

If the receive overflow overwrite enable bit, RXOF (CTL, Bit 8), is set and there is no space left in the FIFO, the valid data in the receive FIFO is overwritten by the new serial byte received. If the RXOF bit is cleared and there is no space left in the FIFO, the new serial byte received is discarded.

When the RXOF bit is set, the contents of the SPI receive FIFO are undefined, and its contents must be discarded by user code.

Full Duplex Operation

Simultaneous reads and writes are supported on the SPI. When implementing full duplex transfers in master mode, use the following procedure:

1. Initiate a transfer sequence via a transmit on MOSIx. Set CTL, Bit 6 = 1. If interrupts are enabled, interrupts are triggered when a transmit interrupt occurs but not when a byte is received.
2. If using interrupts, the SPI transmit interrupt indicated by STAT, Bit 5 or the transmit FIFO underrun interrupt (STAT, Bit 4) is asserted approximately 3 SPI SCLKx to 4 SPI SCLKx periods into the transfer of the first byte. Reload a byte into the transmit FIFO, if necessary, by writing to the SPIx TX register.

SERIAL PERIPHERAL INTERFACES

- The first byte received via the MISO pin does not update the receive FIFO status bits (FIFOSTAT, Bits[11:8]) until 12 SPI SCLKx periods after \overline{CS}_x goes low. Therefore, two transmit interrupts may occur before the first receive byte is ready to be handled.
- After the last transmit interrupt occurs, it may be necessary to read two more bytes. It is recommended that FIFOSTAT, Bits[11:8] be polled outside of the SPI interrupt handler after the last transmit interrupt is handled.

SPI INTERRUPTS

There is one interrupt line per SPI and four sources of interrupts. STAT, Bit 0 reflects the state of the interrupt line, and STAT, Bits[7:4] reflect the state of the four sources.

The SPI generates either TXIRQ or RXIRQ. Both interrupts cannot be enabled at the same time. The appropriate interrupt is enabled using the TIM bit (CTL, Bit 6). If TIM = 1, TXIRQ is enabled. If TIM = 0, RXIRQ is enabled.

All interrupts are sticky and are cleared only when the appropriate interrupt bits in the STAT register are written with 1s. The interrupt line from the device is cleared only after all the interrupt sources are cleared.

Transmit Interrupt

If TIM (CTL, Bit 6) is set, the transmit FIFO status causes the interrupt. IEN, Bits[2:0] control when the interrupt occurs, as shown in [Table 174](#).

Table 174. IEN, Bits[2:0] IRQ Mode Bits

IEN, Bits[2:0]	Interrupt Condition
000	An interrupt is generated after each byte that is transmitted. The interrupt occurs when the byte is read from the FIFO and written to the shift register.
001	An interrupt is generated after every two bytes that are transmitted.
010	An interrupt occurs after every third byte that is transmitted.
011	An interrupt occurs after every fourth byte that is transmitted.
100	An interrupt occurs after every fifth byte that is transmitted.
101	An interrupt occurs after every sixth byte that is transmitted.
110	An interrupt occurs after every seventh byte that is transmitted.
111	An interrupt occurs after every eighth byte that is transmitted.

The interrupts are generated depending on the number of bytes transmitted and not on the number of bytes in the FIFO, which is unlike the receive interrupt that depends on the number of bytes in the receive FIFO and not on the number of bytes received.

The transmit interrupt is cleared by a read to the status register. The status of this interrupt can be read by reading STAT, Bit 5. The interrupt is disabled if CTL, Bit 13 is left high.

A write to the control register, CTL, resets the transmitted byte counter back to 0. For example, in a case where IEN, Bits[2:0] = 0x3 and CTL is written to after three bytes are transmitted, the transmit interrupt does not occur until another four bytes are transmitted.

Receive Interrupt

If the TIM bit (CTL, Bit 6) is cleared, the receive FIFO status causes the interrupt. IEN, Bits[2:0] control when the interrupt occurs. The interrupt is cleared by a read of the STAT register. The status of this interrupt can be read by reading STAT, Bit 6.

Interrupts are only generated when data is written to the FIFO. For example, if IEN, Bits[2:0] are set to 0x00, an interrupt is generated after the first byte is received. When the status register is read, the interrupt is deactivated. If the byte is not read from the FIFO, the interrupt is not regenerated. Another interrupt is not generated until another byte is received in the FIFO.

The interrupt depends on the number of valid bytes in the FIFO and not on the number of bytes received. For example, when IEN, Bits[2:0] = 0x1, an interrupt is generated after a byte is received if there are two or more bytes in the FIFO. The interrupt is not generated after every two bytes received.

The interrupt is disabled if SPIx IEN, Bit 12 is left high.

SERIAL PERIPHERAL INTERFACES

Underrun/Overflow Interrupts

Bit 7 and Bit 4 in the STAT register generate SPI interrupts.

When a transfer starts with no data in the transmit FIFO, Bit 4 in the STAT register is set to indicate an underrun condition, which causes an interrupt. The interrupt and status bit are cleared upon a read of the status register. This interrupt occurs irrespective of IEN, Bits[2:0]. This interrupt is disabled if CTL, Bit 13 is set.

When data is received and the receive FIFO is already full, Bit 7 in the STAT register is set to 1, indicating an overflow condition, which causes an interrupt. The interrupt and status bit are cleared upon a read of the status register. This interrupt occurs irrespective of IEN, Bits[2:0]. This interrupt is disabled if CTL, Bit 12 is set.

When the SPI receive overflow bit (STAT, Bit 7) is set to 1, the contents of the SPI receive FIFO are undetermined and must not be used. The user must flush the receive FIFO upon detecting this error condition.

All interrupts are cleared by either a read of the status register or when CTL, Bit 0 is cleared to 0. The receive and transmit interrupts are also cleared if the relevant flush bits are set to 1. Otherwise, the interrupts remain active even if the SPI is reconfigured.

SPI WIRE-OR'ED MODE (WOM)

To prevent contention when the SPI is used in a multimaster or multislave system, the data output lines, MOS_{ix} and MISO_x, can be configured to behave as open-circuit drivers. An external pull-up resistor is required when this feature is selected. The WOM bit (CTL, Bit 4) controls the pad enable outputs for the data lines.

SPI CSERR CONDITION

The CSERR bit (STAT, Bit 12) indicates if an erroneous deassertion of the \overline{CS}_x signal has been detected before the completion of all eight SCLK_x cycles. This bit generates an interrupt and is available in all modes of operation: slave, master, and during DMA transfers.

If an interrupt generated by the CSERR bit (STAT, Bit 12) occurs, the SPI enable bit (CTL, Bit 0) must be disabled and reenabled to ensure that the recovery and subsequent transfers are error free. The CSRST bit (CTL, Bit 14) must always be set in both slave mode and master mode except when a midbyte stall in SPI communication is required. In this case, the CSERR flag is set but can be ignored.

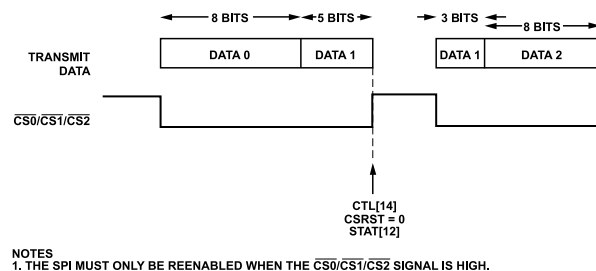

Figure 22. SPI Communication: Midbyte Stall

Note that the SPI must only be reenabled when the \overline{CS}_x signal is high.

SPI DMA

DMA operation is provided on both SPI channels. Two DMA channels are dedicated to transmit and receive. The SPI DMA channels must be configured in the μ DMA controller of the Arm Cortex-M33 processor.

To avoid generating overflow interrupts, the receive FIFO flush bit must be set, or the SPI interrupt must be disabled in the NVIC. If only the DMA receive request (DMA, Bit 2) is enabled, the transmit FIFO is underrun. To avoid an underrun interrupt, the SPI interrupt must be disabled.

The SPI transmit (STAT, Bit 5) and SPI receive (STAT, Bit 6) interrupts are not generated when using DMA. The SPI TXUR (STAT, Bit 4) and RXOF (STAT, Bit 7) interrupts are generated when using DMA. IEN, Bits[2:0] are not used in transmit mode and must be set to 0x00 in receive mode.

The enable bit (DMA, Bit 0) controls the start of a DMA transfer. DMA requests are only generated when enable = 1. At the end of a DMA transfer, that is, when receiving a DMA SPI transfer interrupt, this bit must be cleared to prevent extra DMA requests to the μ DMA controller. The data still present in the transmit FIFO is transmitted if in transmit mode.

SERIAL PERIPHERAL INTERFACES

DMA Master Transmit Configuration

The DMA SPI transmit channel must be configured.

The NVIC must be configured to enable DMA transmit master interrupt (see [Table 11](#)).

When configuring the SPI for DMA mode, note the following:

- ▶ DIV, Bits[15:0] configure the serial clock frequency. This is user configurable.
- ▶ CTL = 0x1043. The CNT register configures the SPI in master mode and transmit mode. The receive FIFO flush is enabled. The CNT register sets the number of bytes to transfer and resolves the odd byte transfer requirement when used with the even byte transfer size of the DMA.
- ▶ The DMA register enables the FIFO to accept 16-bit core data writes. The SPI TX and RX registers are 16-bit in DMA mode.

When all data present in the DMA buffer is transmitted, the DMA generates an interrupt. User code disables the DMA request. Data is still in the transmit FIFO because the DMA request is generated each time there is free space in the transmit FIFO to always keep the FIFO full. User code can check how many bytes are still present in the FIFO using the FIFO status register.

DMA Master Receive Configuration

The CNT register is available in DMA receive master mode only. CNT sets the number of receive bytes required by the SPI master or the number of clocks that the master needs to generate. When the required number of bytes is received, no more transfers are initiated. To initiate a DMA master receive transfer, complete a dummy read by user code. Add this dummy read to the SPIx CNT number.

The counter counting the bytes as they are received is reset either when the SPI is disabled in CTL, Bit 0, or if the CNT register is modified by user code.

SPI AND POWER-DOWN MODES

In master mode, before entering power-down mode, it is recommended to disable the SPI block in CTL, Bit 0. In slave mode, when either transmitting or receiving, interrupt driven or DMA, the \overline{CSx} line level must be checked via the GPIO registers to ensure that the SPI is not communicating and that the SPI block is disabled while the \overline{CSx} line is high. At power-up, the SPI block can be reenabled.

While being powered-down, the following fields are retained:

- ▶ All bit fields of the CTL register except the SPIEN bit. The SPIEN bit is reset to 0 on power-up and to allow a clean start of the design at wake-up.
- ▶ IRQMODE bit field in the IEN register.
- ▶ Value bit field in the DIV register.
- ▶ THREEPIN bit field in the RDCTL register.
- ▶ RDYPOL bit field in the FLOWCTL register.

All other bit fields are not retained. Therefore, they are all reset on power-up. On exiting the power-down mode, the software reprograms all the nonretained registers as required. Then, the SPI block must be reenabled by setting CTL, Bit 0.

REGISTER SUMMARY: SERIAL PERIPHERAL INTERFACE (SPI0, SPI1, SPI2)

Table 175. SPI Register Summary

Address	Name	Description	Reset	RW
SPI0				
0x40054000	STAT	Status.	0x0800	R/W
0x40054004	RX	Receive.	0x0000	R
0x40054008	TX	Transmit.	0x0000	W
0x4005400C	DIV	SPI Baud Rate Selection.	0x0000	R/W
0x40054010	CTL	SPI Configuration 1.	0x0000	R/W
0x40054014	IEN	SPI Configuration 2.	0x0000	R/W
0x40054018	CNT	Transfer Byte Count.	0x0000	R/W
0x4005401C	DMA	SPI DMA Enable.	0x0000	R/W

SERIAL PERIPHERAL INTERFACES

Table 175. SPI Register Summary (Continued)

Address	Name	Description	Reset	RW
0x40054020	FIFOSTAT	FIFO Status.	0x0000	R
0x40054024	RDCTL	Read Control.	0x0000	R/W
0x40054028	FLOWCTL	Flow Control.	0x0000	R/W
0x4005402C	WAITTMR	Wait Timer for Flow Control.	0x0000	R/W
0x40054034	CSOVERRIDE	Chip Select Override.	0x0000	R/W
SPI1				
0x40058000	STAT	Status.	0x0800	R/W
0x40058004	RX	Receive.	0x0000	R
0x40058008	TX	Transmit.	0x0000	W
0x4005800C	DIV	SPI Baud Rate Selection.	0x0000	R/W
0x40058010	CTL	SPI Configuration 1.	0x0000	R/W
0x40058014	IEN	SPI Configuration 2.	0x0000	R/W
0x40058018	CNT	Transfer Byte Count.	0x0000	R/W
0x4005801C	DMA	SPI DMA Enable.	0x0000	R/W
0x40058020	FIFOSTAT	FIFO Status.	0x0000	R
0x40058024	RDCTL	Read Control.	0x0000	R/W
0x40058028	FLOWCTL	Flow Control.	0x0000	R/W
0x4005802C	WAITTMR	Wait Timer for Flow Control.	0x0000	R/W
0x40058034	CSOVERRIDE	Chip Select Override.	0x0000	R/W
SPI2				
0x4005C000	STAT	Status.	0x0800	R/W
0x4005C004	RX	Receive.	0x0000	R
0x4005C008	TX	Transmit.	0x0000	W
0x4005C00C	DIV	SPI Baud Rate Selection.	0x0000	R/W
0x4005C010	CTL	SPI Configuration 1.	0x0000	R/W
0x4005C014	IEN	SPI Configuration 2.	0x0000	R/W
0x4005C018	CNT	Transfer Byte Count.	0x0000	R/W
0x4005C01C	DMA	SPI DMA Enable.	0x0000	R/W
0x4005C020	FIFOSTAT	FIFO Status.	0x0000	R
0x4005C024	RDCTL	Read Control.	0x0000	R/W
0x4005C028	FLOWCTL	Flow Control.	0x0000	R/W
0x4005C02C	WAITTMR	Wait Timer for Flow Control.	0x0000	R/W
0x4005C034	CSOVERRIDE	Chip Select Override.	0x0000	R/W

REGISTER DETAILS: SERIAL PERIPHERAL INTERFACE (SPI0, SPI1, SPI2)

Status Register

SPI0: Address: 0x40054000, Reset: 0x0800, Name: STAT

SPI1: Address: 0x40058000, Reset: 0x0800, Name: STAT

SPI2: Address: 0x4005C000, Reset: 0x0800, Name: STAT

Table 176. Bit Descriptions for STAT

Bits	Bit Name	Settings	Description	Reset	Access
15	RDY		Detected an Edge on Ready Status for Flow Control. This bit indicates that there was an active edge on the SRDYx/MISOx line depending on the flow control mode. If FLOWCTL, Bits[1:0] = 0x2, this bit is set whenever an active edge is detected on the DRDYx signal. If FLOWCTL, Bits[1:0] = 0x3, this bit is set if an active edge is detected on MISOx signal. For all other values of FLOWCTL, Bits[1:0], this bit is always 0.	0x0	R/W1C

SERIAL PERIPHERAL INTERFACES

Table 176. Bit Descriptions for STAT (Continued)

Bits	Bit Name	Settings	Description	Reset	Access
			When IEN, Bit 11 is set, this bit causes an interrupt and is cleared when this bit is read. This bit can be used for staggered flow control on the transmit side, along with a CSx override if required.		
14	CSFALL	0x0 0x1	Detected a Falling Edge on $\overline{\text{CSx}}$ When in Slave Mode. This can be used to identify the start of an SPI data frame. Write 1 to this bit to clear it to 0. Set to 1 if there was a falling edge of $\overline{\text{CSx}}$ line, when the device was a slave in continuous transfer mode and IEN, Bit 8 is asserted.	0x0	R/W1C
13	CSRISE	0x0 0x1	Detected a Rising Edge on $\overline{\text{CSx}}$ when in Slave Mode. This bit causes an interrupt. This can be used to identify the end of an SPI data frame. Write 1 to this bit to clear it to 0. Set to 1 when there was a rising edge of $\overline{\text{CSx}}$ line, when the device was a slave in continuous transfer mode and IEN, Bit 8 is asserted.	0x0	R/W1C
12	CSERR	0x0 0x1	Detected a $\overline{\text{CSx}}$ Error Condition in Slave Mode. Write 1 to this bit to clear it to 0. $\overline{\text{CSx}}$ line was deasserted abruptly by an external master, even before the full byte of data was transmitted completely. This bit causes an interrupt.	0x0	R/W1C
11	CS	0x0 0x1	$\overline{\text{CSx}}$ Status. This uses SCLK to HCLK synchronization. Therefore, there can be a slight delay when $\overline{\text{CSx}}$ changes state. interrupt did not occur. $\overline{\text{CSx}}$ interrupt occurs.	0x1	R
[10:8]	RESERVED		Reserved.	0x0	R
7	RXOVR	0x0 0x1	SPI Rx FIFO Overflow. Write 1 to this bit to clear it to 0. Set when the Rx FIFO was already full when new data was loaded to the FIFO. This bit generates an interrupt except when RFLUSH (Bit 12 in CTL) is set.	0x0	R/W1C
6	RXIRQ	0x0 0x1	SPI Rx IRQ. Set when a receive interrupt occurs. Not available in DMA mode. Write 1 to this bit to clear it to 0. Set when a receive interrupt occurs. This bit is set when TIM (CTL, Bit 6) is cleared, and the required number of bytes have been received.	0x0	R/W1C
5	TXIRQ	0x0 0x1	SPI Tx IRQ. SPI Tx IRQ Status Bit. Not available in DMA mode. Write 1 to this bit to clear it to 0. Set when a transmit interrupt occurs. This bit is set when TIM (CTL, Bit 6) is set, and the required number of bytes have been transmitted.	0x0	R/W1C
4	TXUNDR	0x0 0x1	SPI Tx FIFO Underflow. Write 1 to this bit to clear it to 0. Set to 1 when a transmit is initiated without any valid data in the Tx FIFO. This bit generates an interrupt except when TFLUSH (Bit 13 in CTL) is set.	0x0	R/W1C
3	TXDONE	0x0 0x1	SPI Tx Done in Read Command Mode. Write 1 to this bit to clear it to 0. Set when the entire transmit is completed in a read command. This bit generates an interrupt if IEN, Bit 12 is set.	0x0	R/W1C
2	TXEMPTY	0x0 0x1	SPI Tx FIFO Empty Interrupt. Write 1 to this bit to clear it to 0. Set to 1 when the Tx FIFO is empty and IEN, Bit 14 is set.	0x0	R/W1C
1	XFRDONE	0x0 0x1	SPI Transfer Completion. This bit indicates the status of SPI transfer completion in master mode. Write 1 to this bit to clear it to 0. Set to 1 when the transfer of CNT, Bits[13:0] number of bytes is finished. This bit generates an interrupt if this bit is set.	0x0	R/W
0	IRQ	0x0	SPI Interrupt Status. Cleared when all the interrupt sources are cleared.	0x0	R

SERIAL PERIPHERAL INTERFACES

Table 176. Bit Descriptions for STAT (Continued)

Bits	Bit Name	Settings	Description	Reset	Access
		0x1	Set to 1 when an SPI-based interrupt occurs.		

Receive Register

SPI0: Address: 0x40054004, Reset: 0x0000, Name: RX

SPI1: Address: 0x40058004, Reset: 0x0000, Name: RX

SPI2: Address: 0x4005C004, Reset: 0x0000, Name: RX

Table 177. Bit Descriptions for RX

Bits	Bit Name	Settings	Description	Reset	Access
[15:8]	BYTE2		8-Bit Receive Buffer, Used Only in DMA Mode, where all FIFOs happen as half-word accesses. They return zeros if DMA register is disabled.	0x0	R
[7:0]	BYTE1		8-Bit Receive Buffer.	0x0	R

Transmit Register

SPI0: Address: 0x40054008, Reset: 0x0000, Name: TX

SPI1: Address: 0x40058008, Reset: 0x0000, Name: TX

SPI2: Address: 0x4005C008, Reset: 0x0000, Name: TX

Table 178. Bit Descriptions for TX

Bits	Bit Name	Settings	Description	Reset	Access
[15:8]	BYTE2		8-Bit Transmit Buffer Used Only in DMA Modes, where all FIFOs happen as half-word accesses. They return zeros if DMA register is disabled.	0x0	W
[7:0]	BYTE1		8-Bit Transmit Buffer.	0x0	W

SPI Baud Rate Selection Register

SPI0: Address: 0x4005400C, Reset: 0x0000, Name: DIV

SPI1: Address: 0x4005800C, Reset: 0x0000, Name: DIV

SPI2: Address: 0x4005C00C, Reset: 0x0000, Name: DIV

Table 179. Bit Descriptions for DIV

Bits	Bit Name	Settings	Description	Reset	Access
[15:9]	RESERVED		Reserved.	0x0	R
8	SFR		Slave Free Run Mode. Set only when SPI input clock is $\lt;HCLK/2$. <ul style="list-style-type: none"> 0 Clear to 0 for normal SPI slave read operations. Receive interrupt occurs approximately two SPI clocks into the next byte transfer or on the rising edge of the chip select signal. 1 Set to 1 to enable slave free run mode. Receive interrupt occurs early, on the last SPI clock (eighth clock) of the received byte. 		
[7:6]	RESERVED		Reserved.	0x0	R
[5:0]	DIV		SPI Clock Divider. DIV is the factor used to divide HCLK to generate the serial clock.	0x0	R/W

SERIAL PERIPHERAL INTERFACES

SPI Configuration 1 Register

SPI0: Address: 0x40054010, Reset: 0x0000, Name: CTL

SPI1: Address: 0x40058010, Reset: 0x0000, Name: CTL

SPI2: Address: 0x4005C010, Reset: 0x0000, Name: CTL

Table 180. Bit Descriptions for CTL

Bits	Bit Name	Settings	Description	Reset	Access
15	RESERVED		Reserved.	0x0	R
14	CSRST	0 1	0 If this bit is clear, the bit counter continues from where it stopped. The SPI can receive the remaining bits when \overline{CSx} is asserted, and user code must ignore the CSERR interrupt in the SPI STAT register. 1 If this bit is set, the bit counter is reset after a \overline{CSx} error condition and the user code is expected to clear CTL, Bit 0 (SPIEN). It is strongly recommended to set this bit for a safe recovery after a \overline{CSx} error.	0x0	R/W
13	TFLUSH	0x0 0x1	SPI Tx FIFO Flush Enable. 0x0 Clear this bit to disable Tx FIFO flushing. 0x1 Set this bit to flush the Tx FIFO. This bit does not clear itself and must be toggled if a single flush is required. If this bit is left high, either the last transmitted value or 0x00 is transmitted depending on the ZEN bit. Any writes to the Tx FIFO are ignored while this bit is set.	0x0	R/W
12	RFLUSH	0x0 0x1	SPI Rx FIFO Flush Enable. 0x0 Clear this bit to disable Rx FIFO flushing. 0x1 Set this bit to flush the Rx FIFO. This bit does not clear itself and must be toggled if a single flush is required. If this bit is set, all incoming data is ignored, and no interrupts are generated. If set and TIM = 0, a read of the Rx FIFO initiates a transfer.	0x0	R/W
11	CON	0x0 0x1	Continuous Transfer Enable. 0x0 Cleared by user to disable continuous transfer. Each transfer consists of a single 8-bit serial transfer. If valid data exists in the SPIx TX register, a new transfer is initiated after a stall period of 1 serial clock cycle. 0x1 Set by user to enable continuous transfer. In master mode, the transfer continues until no valid data is available in the SPIx TX register. \overline{CSx} is asserted and remains asserted for the duration of each 8-bit serial transfer until Tx is empty.	0x0	R/W
10	LOOPBACK	0x0 0x1	Loopback Enable. 0x0 Cleared by user to be in normal mode. 0x1 Set by user to connect MISOx to MOSIx and test software.	0x0	R/W
9	OEN	0x0 0x1	Slave MISOx Output Enable. 0x0 Clear this bit to disable the output driver on the MISOx line. The MISOx line is open circuit when this bit is clear. 0x1 Set this bit for MISOx to operate as normal.	0x0	R/W
8	RXOF	0x0 0x1	Rx Overflow Overwrite Enable. 0x0 Cleared by user, the new serial byte received is discarded. 0x1 Set by user, the valid data in the SPI RX register is overwritten by the new serial byte received.	0x0	R/W
7	ZEN	0x0 0x1	Transmit Zeros Enable. 0x0 Clear this bit to transmit the last transmitted value when there is no valid data in the Tx FIFO. 0x1 Set this bit to transmit 0x00 when there is no valid data in the Tx FIFO.	0x0	R/W
6	TIM	0x0 0x1	SPI Transfer and Interrupt Mode. 0x0 Cleared by user to initiate transfer with a read of the RX register. Interrupt only occurs when the Rx FIFO has IEN, Bits[2:0] + 1 number of bytes or more in it. 0x1 Set by user to initiate transfer with a write to the TX register. Interrupt only occurs when IEN, Bits[2:0] + 1 number of bytes have been transmitted.	0x0	R/W
5	LSB	0x0 0x1	LSB First Transfer Enable. 0x0 MSB transmitted first. 0x1 LSB transmitted first.	0x0	R/W
4	WOM		SPI Wire-OR'ed Mode.	0x0	R/W

SERIAL PERIPHERAL INTERFACES

Table 180. Bit Descriptions for CTL (Continued)

Bits	Bit Name	Settings	Description	Reset	Access
		0x0	Normal output levels.		
		0x1	Enables open circuit data output enable (open-drain operation). External pull-ups required on data output pins.		
3	CPOL		Serial Clock Polarity.	0x0	R/W
		0x0	Serial clock idles low.		
		0x1	Serial clock idles high.		
2	CPHA		Serial Clock Phase Mode.	0x0	R/W
		0x0	Serial clock pulses at the end of each serial bit transfer.		
		0x1	Serial clock pulses at the beginning of each serial bit transfer.		
1	MASEN		Master Mode Enable. Clearing this bit issues a synchronous reset to the design and most status bits, while other MMRs are unaffected.	0x0	R/W
		0x0	Enable Slave Mode.		
		0x1	Enable Master Mode.		
0	SPIEN		SPI Enable.	0x0	R/W
		0x0	Disable SPI.		
		0x1	Enable SPI.		

SPI Configuration 2 Register

SPI0: Address: 0x40054014, Reset: 0x0000, Name: IEN

SPI1: Address: 0x40058014, Reset: 0x0000, Name: IEN

SPI2: Address: 0x4005C014, Reset: 0x0000, Name: IEN

Table 181. Bit Descriptions for IEN

Bits	Bit Name	Settings	Description	Reset	Access
15	RESERVED		Reserved.	0x0	R
14	TXEMPTY		Tx FIFO Empty Interrupt Enable.	0x0	R/W
		0x0	Interrupt Disabled.		
		0x1	Interrupt Enabled.		
13	XFRDONE		SPI Transfer Completion Interrupt Enable.	0x0	R/W
		0x0	Interrupt Disabled.		
		0x1	Interrupt Enabled.		
12	TXDONE		SPI Transmit Done Interrupt Enable. This bit enables the TXDONE (STAT, Bit 3) interrupt in read command mode. This can be used to signal the change of SPI transfer direction in read command mode.	0x0	R/W
		0x0	Interrupt Disabled.		
		0x1	Interrupt Enabled.		
11	RDY		Ready Signal Edge Interrupt Enable. This bit enables the STAT, Bit 15 interrupt whenever an active edge occurs on SRDYx/MISOx signals.	0x0	R/W
		0	Interrupt Disabled.		
		1	Interrupt Enabled.		
10	RXOVR		Rx Overflow Interrupt Enable.	0x0	R/W
		0x0	Interrupt Disabled.		
		0x1	Interrupt Enabled.		
9	TXUNDR		Tx Underflow Interrupt Enable.	0x0	R/W
		0x0	Interrupt Disabled.		
		0x1	Interrupt Enabled.		
8	CS		Enable Interrupt on Every \overline{CSx} Edge in Slave Mode.	0x0	R/W
		0x0	Interrupt Disabled.		

SERIAL PERIPHERAL INTERFACES

Table 181. Bit Descriptions for IEN (Continued)

Bits	Bit Name	Settings	Description	Reset	Access
		0x1	If this bit is set and the SPI module is configured as a slave in continuous mode, any edge on \overline{CS}_x generates an interrupt and the corresponding status bits (STAT, Bit 13 and Bit 14) are asserted. This bit has no effect if the SPI is not in continuous mode or if it is a master.		
[7:3]	RESERVED		Reserved.	0x0	R
[2:0]	IRQMODE		SPI IRQ Mode Bits. These bits configure when the Tx/Rx interrupts occur in a transfer. For DMA Rx transfer, these bits are 0b000.	0x0	R/W
		0x0	Interrupt Occurs After 1 Byte is Transferred or Received. Tx interrupt occurs when 1 byte has been transferred. Rx interrupt occurs when 1 or more bytes have been received into the FIFO.		
		0x1	Interrupt Occurs After 2 Byte are Transferred or Received. Tx interrupt occurs when 2 bytes have been transferred. Rx interrupt occurs when 2 or more bytes have been received into the FIFO.		
		0x2	Interrupt Occurs After 3 Bytes are Transferred or Received. Tx interrupt occurs when 3 bytes have been transferred. Rx interrupt occurs when 3 or more bytes have been received into the FIFO.		
		0x3	Interrupt Occurs After 4 Bytes are Transferred or Received. Tx interrupt occurs when 4 bytes have been transferred. Rx interrupt occurs when 4 or more bytes have been received into the FIFO.		
		0x4	Interrupt Occurs After 5 Bytes are Transferred or Received. Tx interrupt occurs when 5 bytes have been transferred. Rx interrupt occurs when 5 or more bytes have been received into the FIFO.		
		0x5	Interrupt Occurs After 6 Bytes are Transferred or Received. Tx interrupt occurs when 6 bytes have been transferred. Rx interrupt occurs when 6 or more bytes have been received into the FIFO.		
		0x6	Interrupt Occurs After 7 Bytes are Transferred or Received. Tx interrupt occurs when 7 bytes have been transferred. Rx interrupt occurs when 7 or more bytes have been received into the FIFO.		
		0x7	Interrupt Occurs After 8 Bytes are Transferred or Received. Tx interrupt occurs when 8 bytes have been transferred. Rx interrupt occurs when 8 or more bytes have been received into the FIFO.		

Transfer Byte Count Register

SPI0: Address: 0x40054018, Reset: 0x0000, Name: CNT

SPI1: Address: 0x40058018, Reset: 0x0000, Name: CNT

SPI2: Address: 0x4005C018, Reset: 0x0000, Name: CNT

This register is only used in master mode.

Table 182. Bit Descriptions for CNT

Bits	Bit Name	Settings	Description	Reset	Access
15	FRAMECONT		Continue SPI Data Frame. Use this bit in conjunction with CON, Bit 11, and CNT Bits[13:0]. If CNT, Bits[13:0] = 0, then this field has no effect because the SPI master continues with transfers if the Tx or Rx FIFO is ready. If CON, Bit 11 = 0, then this field has no effect because all SPI frames are single byte wide irrespective of other control fields.	0x0	R/W
		0x0	This bit is cleared when the SPI master transfers only one frame of bytes set by CNT Bits[13:0].		
		0x1	Set to 1 when the SPI master transfers each data in frames of bytes set by CNT, Bits[13:0].		
14	RESERVED		Reserved.	0x0	R
[13:0]	VALUES		Transfer Byte Count. This count indicates the number of bytes to be transferred. This count is used in both receive and transmit transfer types. The count value ensures that a master mode transfer terminates at the proper time and that 16-bit DMA transfers are byte padded or discarded as required to match odd transfer counts. Reset by clearing CTL, Bit 0 or if the CNT register is updated.	0x0	R/W

SERIAL PERIPHERAL INTERFACES

SPI DMA Enable Register

SPI0: Address: 0x4005401C, Reset: 0x0000, Name: DMA

SPI1: Address: 0x4005801C, Reset: 0x0000, Name: DMA

SPI2: Address: 0x4005C01C, Reset: 0x0000, Name: DMA

Table 183. Bit Descriptions for DMA

Bits	Bit Name	Settings	Description	Reset	Access
[15:3]	RESERVED		Reserved.	0x0	R
2	RXEN	0x0 0x1	Enable Receive DMA Request. Disable Tx DMA interrupt. Enable Tx DMA interrupt.	0x0	R/W
1	TXEN	0x0 0x1	Enable Transmit DMA Request. This bit needs to be cleared as soon as a Tx DMA done interrupt is received to prevent extra Tx DMA requests to the μ DMA controller. Disable Tx DMA interrupt. Enable Tx DMA interrupt.	0x0	R/W
0	EN	0x0 0x1	Enable DMA for data transfer. This bit must be cleared to prevent extra DMA request to the μ DMA controller. Disable to end DMA transfer. Enable to start DMA transfer.	0x0	R/W

FIFO Status Register

SPI00: Address: 0x40054020, Reset: 0x0000, Name: FIFOSTAT

SPI01: Address: 0x40058020, Reset: 0x0000, Name: FIFOSTAT

SPI02: Address: 0x4005C020, Reset: 0x0000, Name: FIFOSTAT

Table 184. Bit Descriptions for FIFOSTAT

Bits	Bit Name	Settings	Description	Reset	Access
[15:12]	RESERVED		Reserved.	0x0	R
[11:8]	RX	0x0 0x1 0x2 0x3 0x4 0x5 0x6 0x7 0x8	SPI Rx FIFO Status. This bit specifies the number of bytes in the Rx FIFO when DMA is disabled. In DMA mode, it refers to the number of half words in the Rx FIFO. Rx FIFO empty. 1 valid byte/half word in Rx FIFO. 2 valid bytes/half words in Rx FIFO. 3 valid bytes/half words in Rx FIFO. 4 valid bytes/half words in Rx FIFO. 5 valid bytes/half words in Rx FIFO. 6 valid bytes/half words in Rx FIFO. 7 valid bytes/half words in Rx FIFO. 8 valid bytes/half words in Rx FIFO (Rx FIFO full). All other combinations are reserved.	0x0	R
[7:4]	RESERVED		Reserved.	0x0	R
[3:0]	TX	0x0 0x1 0x2 0x3 0x4 0x5	SPI Tx FIFO Status. This bit specifies the number of bytes in Tx FIFO when DMA is disabled. In DMA mode, it refers to the number of half words in Tx FIFO. Tx FIFO empty. 1 valid byte/half word in Tx FIFO. 2 valid bytes/half words in Tx FIFO. 3 valid bytes/half words in Tx FIFO. 4 valid bytes/half words in Tx FIFO. 5 valid bytes/half words in Tx FIFO.	0x0	R

SERIAL PERIPHERAL INTERFACES

Table 184. Bit Descriptions for FIFOSTAT (Continued)

Bits	Bit Name	Settings	Description	Reset	Access
		0x6	6 valid bytes/half words in Tx FIFO.		
		0x7	7 valid bytes/half words in Tx FIFO.		
		0x8	8 valid bytes/half words in Tx FIFO (Tx FIFO full).		
			All other combinations are reserved.		

Read Control Register

SPI0: Address: 0x40054024, Reset: 0x0000, Name: RDCTL

SPI1: Address: 0x40058024, Reset: 0x0000, Name: RDCTL

SPI2: Address: 0x4005C024, Reset: 0x0000, Name: RDCTL

This register is only used in master mode.

Table 185. Bit Descriptions for RDCTL

Bits	Bit Name	Settings	Description	Reset	Access
[15:9]	RESERVED		Reserved.	0x0	R
8	THREEPIN	0x0 0x1	Three-Pin SPI Mode. This field specifies if the SPI interface has a bidirectional data pin (3-pin interface) or dedicated unidirectional data pins for Tx and Rx (4-pin interface). This is only valid in read command mode and when FLOWCTL, Bits[1:0] = 0x1. If 3-pin mode is selected, then the MOSIx line is driven by the master during transmit phase. After a wait time of cycles set in WAITTMR, Bits[15:0], the slave is expected to drive the same MOSIx line. FLOWCTL, Bits[1:0] must be programmed to 0x1 to introduce wait states for allowing turnaround time. Otherwise, the slave only has a turnaround time of half the SCLKx period (between sampling and driving edges of SCLKx). If this mode is used, RDCTL, Bit 1 must be 0. 0x0 SPI in 4-pin Interface. 0x1 SPI in 3-pin Interface	0x0	R/W
[7:6]	RESERVED		Reserved.	0x0	R
[5:2]	TXBYTES		Transmit Byte Count for Read Command. This bit specifies the number of bytes to be transmitted – 1 before reading data from a slave. This bit can take values from 0 to 15 corresponding to 1 to 16 Tx bytes. If there is a latency between the command transmission and data reception, the number of Tx bytes (mostly 0s) to be padded for that delay must also be accounted for in this count.	0x0	R/W
1	OVERLAP	0x0 0x1	Tx/Rx Overlap Mode. In most of the slaves, the read data starts only after the master completes the transmission of command + address. In case of overlapping mode, Bits[13:0] in the CNT register refer to the total number of bytes to be received. Therefore, the extra status bytes (which are in addition to the actual read bytes) must be accounted for while programming CNT, Bits[13:0]. 0x0 Overlap disabled. 0x1 Overlap enabled	0x0	R/W
0	CMDEN	0x0 0x1	Read Command Enable. This bit specifies read command mode where a command + address is transmitted and read data is expected in the same CSx frame. 0x0 Read command disabled. 0x1 Read command enabled.	0x0	R/W

Flow Control Register

SPI0: Address: 0x40054028, Reset: 0x0000, Name: FLOWCTL

SPI1: Address: 0x40058028, Reset: 0x0000, Name: FLOWCTL

SPI2: Address: 0x4005C028, Reset: 0x0000, Name: FLOWCTL

This register is only used in master mode.

SERIAL PERIPHERAL INTERFACES

Table 186. Bit Descriptions for FLOWCTL

Bits	Bit Name	Settings	Description	Reset	Access
[15:6]	RDBURSTSZ		Read Data Burst Size. This bit specifies the number of bytes to be received – 1 in a single burst from a slave before waiting for flow control. This is not valid if mode (FLOWCTL, Bits[1:0]) is disabled. For all other values of FLOWCTL, Bits[1:0], this bit is valid. This bit can take values from 0 to 1023, implying a read burst of 1 to 1024 bytes, respectively. This mode is useful for reading fixed width conversion results periodically.	0x0	R/W
5	RESERVED		Reserved.	0x0	R
4	RDYPOL	0x0 0x1	Polarity of SRDYx/MISOx Line. 0x0 Polarity is Active High. SPI Master Waits Until SRDYx/MISOx Becomes high. 0x1 Polarity is Active Low. SPI Master Waits Until SRDYx/MISOx Becomes low.	0x0	R/W
[3:2]	RESERVED		Reserved.	0x0	R
[1:0]	MODE	0x0 0x1 0x2 0x3	Flow Control Mode. When SRDYx signal is used for flow control, any signal can be tied to this SRDYx input of the SPI module. For example, it can be an off-chip input, an on-chip timer output, or any other control signal. 0x0 Flow Control is Disabled. 0x1 Flow Control is Based on Timer (WAITTMR register). 0x2 Flow Control is Based on SRDYx Signal. 0x3 Flow Control is Based on MISOx Signal.	0x0	R/W

Wait Timer for Flow Control Register

SPI0: Address: 0x4005402C, Reset: 0x0000, Name: WAITTMR

SPI1: Address: 0x4005802C, Reset: 0x0000, Name: WAITTMR

SPI2: Address: 0x4005C02C, Reset: 0x0000, Name: WAITTMR

This register is only used in master mode.

Table 187. Bit Descriptions for WAITTMR

Bits	Bit Name	Settings	Description	Reset	Access
[15:0]	TRIMS		Wait Timer for Flow Control. This bit specifies the number of SCLK cycles to wait before continuing the SPI read. This field can take values of 0 to 65,535. This field is only valid if FLOWCTL[1:0] = 1. A value of 0 implies a wait time of 1 SCLK cycle.	0x0	R/W

Chip Select Override Register

SPI0: Address: 0x40054034, Reset: 0x0000, Name: CSOVERRIDE

SPI1: Address: 0x40058034, Reset: 0x0000, Name: CSOVERRIDE

SPI2: Address: 0x4005C034, Reset: 0x0000, Name: CSOVERRIDE

This register is only used in master mode.

Table 188. Bit Descriptions for CSOVERRIDE

Bits	Bit Name	Settings	Description	Reset	Access
[15:2]	RESERVED		Reserved.	0x0	R
[1:0]	CTL	0x0 0x1 0x2	\overline{CSx} Override Control. This bit overrides the actual \overline{CSx} output from the master state machine. It may be needed for special SPI transfers. Use this register with caution because the SPI hardware expects 8 bits per byte. If this condition is not met, the internal bit shift counter can go out of synchronization, resulting in incorrect values received or transmitted. 0x0 Disable \overline{CSx} override. 0x1 \overline{CSx} is forced to drive 0x1. 0x2 \overline{CSx} is forced to drive 0x0. All other combinations are reserved.	0x0	R/W

MDIO

MDIO FEATURES

The MDIO interface hardware can receive complete MDIO frames without software intervention. The MDIO interface hardware can also transmit complete MDIO frames without software intervention if the data to be sent is provided before receiving the turnaround bits of the read or post read increment address frame. To assist in using and supplying the relevant data, interrupts are generated at the end of every complete frame. If the PHYADR or DEVADD received does not match the expected values, the frame is not acted upon. Interrupts can also be generated after every valid PHYADR and DEVADD to permit more sophisticated control within frames.

MDIO OVERVIEW

This MDIO interface is designed for compliance with C formfactor pluggable (CFP) management interface architecture (as per Draft CFP MSA Management Interface Specification Version 2.0 r07, June 30, 2011) as shown in Figure 23. This architecture includes an MDIO hardware interface to handle the serial communications. The data between this CFP MDIO interface and the MDIO defined memory blocks is transferred via software.

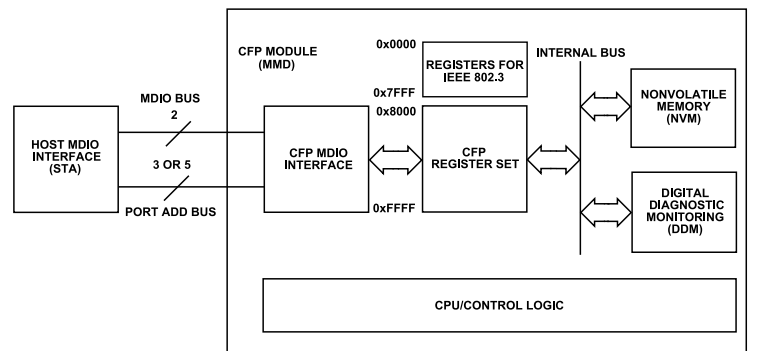

Figure 23. CFP Management interface Architecture

MDIO OPERATION

MDIO Frame Structure

The MDIO interface uses the communication data frame structure defined in IEEE® 802.3™ Clause 45. The frame structure is shown in Figure 24. See the IEEE 802.3 standard for all DEVADD device type MDIO definitions. Each frame can be either an address frame or a data frame. The total bit length of each frame is 64, consisting of 32 bits of preamble, and the frame command body. The command body consists of six portions, as illustrated in Figure 24. More information about the various frame types is provided in Table 189. All values are transmitted MSB first.

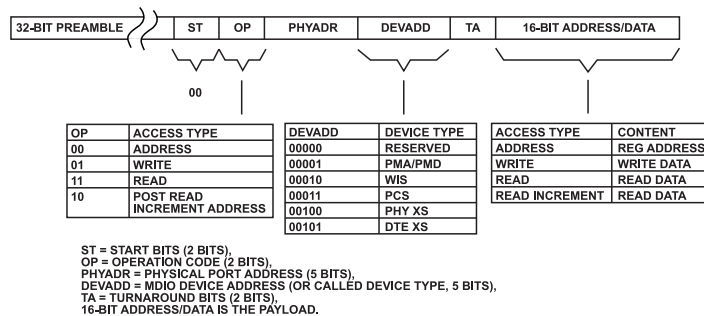

Figure 24. MDIO Frame Structure

Table 189. Frame Details for Different Frame Types¹

Frame	Idle	Management Frame Fields						Address/Data	Idle
		PRE	ST	OP	PHYADR	DEVADD	TA		
Write Address	High-Z	1...1	00	00	aaaa	aaaa	10	aaaaaaaaaaaaaaaa	High-Z
Write Data	High-Z	1...1	00	01	aaaa	aaaa	10	ddddddddddddddd	High-Z

MDIO

Table 189. Frame Details for Different Frame Types¹ (Continued)

Frame	Idle	Management Frame Fields							Idle
		PRE	ST	OP	PHYADR	DEVADD	TA	Address/Data	
Read Data	High-Z	1...1	00	11	aaaaa	aaaaa	Z0	ddddddddddddddd	High-Z
Post Read Increment Address	High-Z	1...1	00	10	aaaaa	aaaaa	Z0	ddddddddddddddd	High-Z

¹ During the idle condition, MDC and MDIO are not actively driven. During the second turnaround (TA) bit and during the 16-bit data of the read and post read increment address frames, MDIO is driven by the ADuCM410/ADuCM420. Z0 means TA is high-Z followed by a 0.

Idle Condition (Idle)

The idle condition for the MDIO is a high impedance state.

Preamble (PRE)

At the beginning of each transaction, the station management entity (STA) host sends a sequence of at least 32 contiguous bits one bit at a time to the MDIO, with 32 corresponding clock cycles on MDC, to establish the start of a frame.

Start of Frame (ST)

After the preamble, ST (consisting of two zero bits) indicates the start of the frame information.

Operation Code (OP)

OP specifies the action to be taken, as described in [Table 190](#).

Table 190. Operation Code

OP	Descriptions
00	Set the address for a subsequent write or read frame.
01	Write to the previously set address.
11	Read from the previously set address.
10	Read from the previously set address. Then increment the address. The user code must increment the address in the MDADR register.

Physical Address (PHYADR)

This address is five bits, allowing 32 unique addresses. The PHYADR is set either by five pins or by software.

Device Address (DEVADD)

This address is five bits and selects the device type. In the CFP standard, only MDIO Device Address 1 is supported.

Turnaround (TA)

This time is used to change from being driven by the STA to being driven by the MDIO manageable devices (ADuCM410 or ADuCM420 MDIO slave) as per [Figure 24](#).

Address/Data

The address/data field is 16 bits.

Typical Usage Sequence

Most of the MDIO interface is implemented in hardware, thus requiring minimal software effort.

1. Enable the MDIO onto the physical pins by writing 0x1555 to GP3CON.
2. Set the frame parameters by means of MDPHY, MDCON, and MDPIN.
3. Set the interrupts with MDIEN plus the required system interrupt settings. At this stage, the address and write frames can be received in MDRXD and MDADR, respectively.

MDIO

- Data must be placed in MDTXD in advance of the read or post read increment address frame so that it can be automatically inserted for the frame.

No software intervention is required during any of the transmissions, although frame progress can be monitored with MDFRM during or upon completion of each frame. Do not use MDSTA to check the frame progress because this MMR is automatically cleared, and bits can be lost if read at an inappropriate time. If it is required to monitor frame progress, base the appropriate time to read MDSTA on interrupts or poll the MDIO interrupt bit in ISPR0 in the interrupt system. Read MDSTA only once per frame. The MDIO must have the highest interrupt priority of all peripherals. Otherwise, MDIO events are likely to be lost.

MDIO Interrupt Power-Up Register Write Sequence

To avoid false MDIO interrupts on startup, the order of register writes is important. The following is a code example showing how to correctly configure the MDIO interrupt on startup:

```
pADI_MDIO->MDCON = 0x0006;
pADI_MDIO->MDPHY = 0x0700;
sta = pADI_MDIO->MDSTA;           //read the MDSTA register to clear any interrupts
pADI_MDIO->MDIEN = 0x000F;
NVIC_ClearPendingIRQ(MDIO_IRQn); //clear any pending interrupts in the Cortex
```

REGISTER SUMMARY: MDIO INTERFACE

Table 191. MDIO Register Summary

Address	Name	Description	Reset	Access
0x40022000	MDCON	MDIO Block Control.	0x0000	R/W
0x40022004	MDFRM	MDIO Received Frame Control Information.	0x0000	R
0x40022008	MDRXD	MDIO Received Data.	0xFFFF	R
0x4002200C	MDADR	MDIO Received Address.	0xFFFF	R
0x40022010	MDTXD	MDIO Data for Transmission.	0x0000	R/W
0x40022014	MDPHY	MDIO PHYADR Software Values and Selection and DEVADD.	0x0400	R/W
0x40022018	MDSTA	MDIO Progress Signaling Through Frame.	0x0000	R
0x4002201C	MDIEN	MDIO Interrupt Enables.	0x0000	R/W
0x40022020	MDPIN	MDIO Read PHYADR Pins.	0x001F	R
0x40022028	DMAEN	MDIO DMA Enable.	0x0000	R/W
0x4002202C	MDTESTCON	MDIO TA Bit Control Register.	0x0800	R/W

REGISTER DETAILS: MDIO INTERFACE

MDIO Block Control Register

Address: 0x40022000, Reset: 0x0000, Name: MDCON

Control for the MDIO block.

Table 192. Bit Descriptions for MDCON

Bits	Bit Name	Settings	Description	Reset	Access
[15:9]	RESERVED		Reserved.	0x0	R
8	MD_EN		MDIO Enable. 0 MDIO is disabled. Changing this bit from 1 to 0 resets all MDIO block settings. 1 MDIO is enabled.	0x0	R/W
[7:3]	RESERVED		Reserved.	0x0	R
2	MD_DRV		Enable Open Drain or Push/Pull of MDIO Output Pin Drivers. 0 MDIO Open Drain. 1 MDIO Push/Pull.	0x0	R/W
1	MD_PHM		Enable PHY Address Bit Width.	0x0	R/W

MDIO

Table 192. Bit Descriptions for MDCON (Continued)

Bits	Bit Name	Settings	Description	Reset	Access
		0	5 Bits. PHYADD is active.		
		1	3 Bits. PHYADD is active, two MSBS are ignored.		
0	MD_RST		Reset MDIO Block.	0x0	W
		0	Writing 0 has no effect on the MDIO block.		
		1	Reset MDIO block by setting to 1. Internal hardware automatically clears this bit to 0.		

MDIO Received Frame Control Information Register

Address: 0x40022004, Reset: 0x0000, Name: MDFRM

Contains control information of last frame received.

Table 193. Bit Descriptions for MDFRM

Bits	Bit Name	Settings	Description	Reset	Access
[15:12]	RESERVED		Reserved.	0x0	R
[11:7]	MD_DEV		Received DEVADD. Only 0x01 is supported.	0x0	R
[6:2]	MD_PHY		Received PHYADR.	0x0	R
[1:0]	MD_OP		Received OP.	0x0	R
		00	Address Frame.		
		01	Write Frame.		
		10	Post Read Increment Address Frame.		
		11	Read Frame.		

MDIO Received Data Register

Address: 0x40022008, Reset: 0xFFFF, Name: MDRXD

Data received from last write frame.

Table 194. Bit Descriptions for MDRXD

Bits	Bit Name	Settings	Description	Reset	Access
[15:0]	MD_RXD		Received Data	0xFFFF	R

MDIO Received Address Register

Address: 0x4002200C, Reset: 0xFFFF, Name: MDADR

Data received from last address frame.

Table 195. Bit Descriptions for MDADR

Bits	Bit Name	Settings	Description	Reset	Access
[15:0]	MD_ADR		Received Address	0xFFFF	R

MDIO Data for Transmission Register

Address: 0x40022010, Reset: 0x0000, Name: MDTXD

Data to be transmitted by next data frame.

Table 196. Bit Descriptions for MDTXD

Bits	Bit Name	Settings	Description	Reset	Access
[15:0]	MD_TXD		Tx Data. Data that is transmitted by the next read or post read increment address frame.	0x0	R/W

MDIO

MDIO PHYADR Software Values and Selection and DEVADD Register

Address: 0x40022014, Reset: 0x0400, Name: MDPHY

Sets Expected Values for Control Part of Frame

Table 197. Bit Descriptions for MDPHY

Bits	Bit Name	Settings	Description	Reset	Access
15	RESERVED		Reserved.	0x0	R
[14:10]	MD_DEVADD		Expected DEVADD. Normally 01.	0x1	R/W
[9:5]	MD_PHYSEL		Selects Expected PHYADR Bits. For each of the 5 bits: 0 Sets expected PHYADR, Bit x = PRTADDRx, where x = 0 to 4. For example, PHYADR, Bit 0 = PRTADDR0. 1 Sets expected PHYADR, Bit x = MD_PHYSW, Bit x, where x = 0 to 4. For example, PHYADR, Bit 0 = MD_PHYSW, Bit 0.	0x0	R/W
[4:0]	MD_PHYSW		Software Provided PHYADR. Chosen according to corresponding MD_PHYSEL.	0x0	R/W

MDIO Progress Signaling Through Frame Register

Address: 0x40022018, Reset: 0x0000, Name: MDSTA

MDSTA reflects the matching of the incoming signal (frame) on the MDIO pins. Matching and not matching refer to the signal matching the PHYADR and DEVADD register values.

Table 198. Bit Descriptions for MDSTA

Bits	Bit Name	Settings	Description	Reset	Access
[15:8]	RESERVED		Reserved.	0x0	R
7	MD_PHYN		PHY Address Not Matching Status. Set at end of PHYADR if PHYADR not matching. Cleared by reading the MMR.	0x0	RC
6	MD_PHYM		PHY Address Matching Status. Set at end of PHYADR if PHYADR matching. Cleared by reading the MMR.	0x0	RC
5	MD_DEVN		Device Address None Match Status. Set at end of DEVADD if DEVADD not matching. Cleared by reading the MMR.	0x0	RC
4	MD_DEVM		Device Address Matching Status. Set at end of DEVADD if DEVADD matching. Cleared by reading the MMR.	0x0	RC
3	MD_RDF		Read Frame Status. Set at end of read frame. Cleared by reading the MMR.	0x0	RC
2	MD_INCF		Post Read Increment Address Frame Status. Set at end of post read increment address frame. Cleared by reading the MMR.	0x0	RC
1	MD_ADRF		Address Frame Status. Set at end of address frame. Cleared by reading the MMR.	0x0	RC
0	MD_WRF		Write Frame Status. Set at end of write frame. Cleared by reading the MMR.	0x0	RC

MDIO Interrupt Enables Register

Address: 0x4002201C, Reset: 0x0000, Name: MDIEN

Enables interrupts on specified events.

Table 199. Bit Descriptions for MDIEN

Bits	Bit Name	Settings	Description	Reset	Access
[15:8]	RESERVED		Reserved.	0x0	R
7	MD_PHYNI		Interrupt Enable for MD_PHYN. If set, the interrupt is requested when MD_PHYN becomes active.	0x0	R/W
6	MD_PHYMI		Interrupt Enable for MD_PHYM. If set, the interrupt is requested when MD_PHYM becomes active.	0x0	R/W
5	MD_DEVNI		Interrupt Enable for MD_DEVN. If set, the interrupt is requested when MD_DEVN becomes active.	0x0	R/W
4	MD_DEVMI		Interrupt Enable for MD_DEVM. If set, the interrupt is requested when MD_DEVM becomes active.	0x0	R/W
3	MD_RDFI		Interrupt Enable for MD_RDF. If set, the interrupt is requested when MD_RDF becomes active.	0x0	R/W

MDIO

Table 199. Bit Descriptions for MDIEN (Continued)

Bits	Bit Name	Settings	Description	Reset	Access
2	MD_INCFI		Interrupt Enable for MD_INCF. If set, the interrupt is requested when MD_INCF becomes active.	0x0	R/W
1	MD_ADRI		Interrupt Enable for MD_ADRF. If set, the interrupt is requested when MD_ADRF becomes active.	0x0	R/W
0	MD_WRFI		Interrupt Enable for MD_WRF. If set, the interrupt is requested when MD_WRF becomes active.	0x0	R/W

MDIO Read PHYADDR Pins Register

Address: 0x40022020, Reset: 0x0000, Name: MDPIN

Reads the MDIO address pins.

Table 200. Bit Descriptions for MDPIN

Bits	Bit Name	Settings	Description	Reset	Access
[15:5]	RESERVED		Reserved.	0x0	R
[4:0]	MD_PIN		PRTADDRx Pins. Reads PRTADDRx pins.	0x1F	R

MDIO DMA Enable Register

Address: 0x40022028, Reset: 0x0000, Name: DMAEN

Table 201. Bit Descriptions for DMAEN

Bits	Bit Name	Settings	Description	Reset	Access
[15:4]	RESRRVED		Reserved	0x0	R/W
3	WR_DATA		Write Data	0x0	R/W
2	WR_ADR		Write Address	0x0	R/W
1	INCRD_DATA		Increment Read Data	0x0	R/W
0	RD_DATA		Read Data	0x0	R/W

MDIO TA Bit Control Register

Address: 0x4002202C, Reset: 0x0800, Name: MDTESTCON

Table 202. Bit Descriptions for MDTESTCON

Bits	Bit Name	Settings	Description	Reset	Access
[15:14]	RESERVED		Reserved.	0x0	R
13	EN_TA_OUTPUT		Enable TA Bit Output Control During OP Phase.	0x0	R/W
12	TA_1_VALUE		Output Value During Second Bit of OP Phase.	0x0	R/W
11	TA_0_VALUE		Output Value During First Bit of OP Phase.	0x1	R/W
[10:0]	RESERVED		Reserved.	0x0	R/W

DIGITAL INPUTS/OUTPUTS

DIGITAL INPUTS/OUTPUTS FEATURES

The ADuCM410 and ADuCM420 feature multiple bidirectional general-purpose digital input/output (GPIO) pins. Most of the GPIO pins have multiple functions, configurable by user code. At power-up, all but one of these pins are configured as GPIOs. One pin (P2.2/POR/CLKOUT/SWO) reflects the state of the POR. This pin can also be configured by user code to be used as a GPIO. On power-up, these pins are configured as inputs with their corresponding pull-up or pull-down disabled. There are six 8-bit wide ports. However, not all bits on some ports are accessible. Inaccessible bits must be ignored.

DIGITAL INPUTS/OUTPUTS BLOCK DIAGRAM

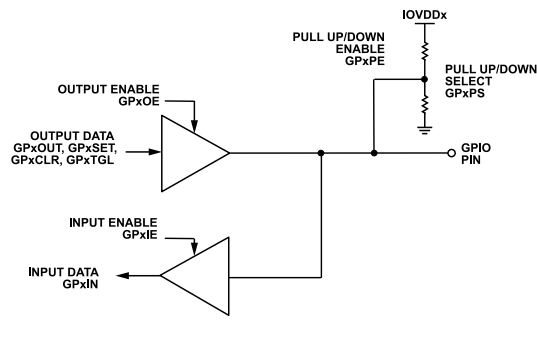

Figure 25. GPIO Block diagram

DIGITAL INPUTS/OUTPUTS OVERVIEW

The GPIOs are grouped into six ports: Port 0 to Port 5. Each GPIO can be configured as an input, output, or fully open circuit. In input mode, the internal pull-up/pull-down can be enabled by software. All GPIOs except P3.0 to P3.6 in MDIO mode are functional over the full supply range (IOVDD0 = 2.85 V to 3.6 V (maximum)).

The absolute maximum input voltage is $IOVDDx + 0.3$ V. When the ADuCM410 and ADuCM420 enter a power saving mode, the GPIO pins retain their states.

Configurable GPIO Power Supply Control

The ADuCM410 and ADuCM420 have two digital power supply rails: IOVDD0 and IOVDD1.

IOVDD0 is nominally a 3 V supply rail. IOVDD1 is nominally a 1.2 V or 1.8 V supply rail. See the ADuCM410 and ADuCM420 data sheets for the full input voltage ranges.

For P0.3 to P0.0 and P1.7 to P1.0, the I/O supply rail is selected by GP0PWR and GP1PWR. Each of these pins can be configured for its output stage to be powered from either IOVDD0 or IOVDD1.

The 1.2 V supply is only recommended for GPIO mode and SPI mode and is not recommended for UART or I²C mode.

Inaccessible Bits

Some of the bits of P2, P3, P4, and P5 are not connected to external pins. The pin definitions in [Table 205](#) indicate which are accessible. The inaccessible bits are still implemented. Therefore, the pull-ups/pull-downs for these bits must be disabled using the GPxPE MMRs so that they do not consume excess power. Unused outputs must also be disabled using the GPxOE MMRs. These settings are the default at power-up.

DIGITAL INPUTS/OUTPUTS OPERATION

Each digital input/output is configured, read, and written independent of the other bits.

General-Purpose Input Data (GPxIN)

GPxIN contains the pin input levels if enabled as inputs by GPxIE.

DIGITAL INPUTS/OUTPUTS

General-Purpose Output Data (GPxOUT)

The values of GPxOUT are output on the GPIO pins when configured as outputs by GPxOE.

Input/Output Data Out Enable (GPxOE)

GPxOE enables the values of GPxOUT to be output on the GPIO pins.

Input/Output Pull-Up Enable GPxPE

In input mode, GPxPE enables/disables internal pull-ups/pull-downs. All Port 0 to Port 3 pins have internal pull-ups and internal pull-downs. The pull-ups/pull-downs are implemented as MOSFET transistors. Therefore, the pull-up current varies with the voltage applied to the pin.

If a pin is configured as an output, the internal pull-up/pull-down is disabled even in open-drain mode.

Input/Output Data In Enable (GPxIE)

GPxIE enables the GPIO pin input levels to be available in GPxIN.

Open-Drain Enable (GPxODE)

GPxODE configures pins in output mode to open-drain mode. In this mode, the outputs can sink current if the corresponding bit in GPxOUT, Bits[7:0] is low. If the bit in GPxOUT, Bits[7:0] is high, the pin is high impedance.

To enable a pin as an open-drain output, set the appropriate bits in GPxOEN and GPxODE.

If a pin is configured as an output, the internal pull-up is disabled even in open-drain mode, regardless of GPxPE, Bits[7:0].

If internal pull-ups are required in open drain mode, it is possible to configure the GPIOs in pseudo open-drain mode, by setting the corresponding bits of GPxOUT and GPxODE to 0b0 and the corresponding bit of GPxPE to 0b1. To change between a low output and an open-drain high output with a pull-up, the corresponding bit in GPxOE can be changed from 0b1 to 0b0.

Bit Set

Bit set mode sets one or more GPIO data outputs without affecting other outputs within a port. Only the GPIO corresponding with the write data bit equal to 1 is set. The remaining GPIOs are unaffected.

Bit Clear

Bit clear mode clears one or more GPIO data outputs without affecting other outputs within a port. Only the GPIO corresponding with the write data bit equal to 1 is cleared. The remaining GPIOs are unaffected.

Bit Toggle

Bit toggle mode toggles one or more GPIO data outputs without affecting other outputs within a port. Only the GPIO corresponding to the write data bit equal to 1 is toggled. The remaining GPIOs are unaffected.

Drive Strength Control

GPIO drive strength can be controlled depending on user configuration. Each GPIO port has a drive strength control register, GPxDS, Bits[15:0]. The value of the register bits determines the drive strength, as shown in [Table 203](#).

Note the order of the DSx bits in [Table 203](#). A setting of 0x1 results in a higher driver strength than 0x2.

I²C Channel 0 and Channel 2 have a current sink capability to 20 mA. I²C Channel 1 is limited to a 12 mA maximum current sink.

Table 203. Drive Strength Control Table

Drive Strength (DSx, Bits[15:0])	GPIOs with I2C0/I2C2 Function (mA)	All Other GPIOs (mA)
0x0	2	2
0x2	8	4

DIGITAL INPUTS/OUTPUTS

Table 203. Drive Strength Control Table (Continued)

Drive Strength (DSx, Bits[15:0])	GPIOs with I2C0/I2C2 Function (mA)	All Other GPIOs (mA)
0x1	16	8
0x3	20	12

INTERRUPTS

Each GPIO pin can be associated with an interrupt. Interrupts can be independently enabled for each GPIO pin and are always edge triggered. Only one interrupt is generated with each GPIO pin transition. The polarity of the detected edge can be positive (low to high) or negative (high to low). Each GPIO interrupt event can be mapped to one of two interrupts, Interrupt A or Interrupt B, allowing the system more flexibility in terms of how GPIO interrupts are grouped for servicing and how interrupt priorities are set. The interrupt status of each GPIO pin can be determined and cleared by accessing the GPxINT status registers. Set the appropriate bit in the GPxIENx registers to enable the full input path.

Interrupt Polarity

The polarity of the interrupt determines if the interrupt is accepted on the rising or the falling edge. Each GPIO pin has a corresponding interrupt register (GPxPOL) based on the port in which it is grouped. The interrupt registers configure the interrupt polarity of each pin. When set to 0, an interrupt event latches on a high to low transition on the corresponding pin. When set to 1, an interrupt event latches on a low to high transition on the corresponding pin.

Interrupt A Enable

Each GPIO port has a corresponding Interrupt Enable A register (GPxIENA) that is enabled or masked for each pin in the port. The bits in these registers determine if a latched edge event interrupts the core (Interrupt A) or is masked. In either case, the occurrence of the event is captured in the corresponding bit of the GPxINT status register. When set to 0, Interrupt A is not enabled (masked). No interrupts to the core are generated by this GPIO pin. When set to 1, Interrupt A is enabled. On a valid detected edge, an interrupt source to the core is generated.

Interrupt B Enable

Each GPIO port has a corresponding Interrupt B enable register (GPxIENB) that is enabled or masked for each pin in the port. The bits in these registers determine if a latched edge event interrupts the core (Interrupt B) or is masked. In either case, the occurrence of the event is captured in the corresponding bit of the GPxINT status register. When set to 0, Interrupt B is not enabled (masked). No interrupts to the core are generated by this GPIO pin. When set to 1, Interrupt B is enabled. On a valid detected edge, an interrupt source to the core is generated.

Interrupt Status

Each GPIO port has an interrupt status register (GPxINT) that captures the interrupts occurring on its pins. These register bits indicate that the appropriately configured rising or falling edge has been detected on the corresponding GPIO pin.

When an event is detected, GPxINT remains set until cleared, even if the GPIO pin transitions back to a nonactive state. Out of reset, pull-up resistors combined with falling edge detect can result in the GPxINT status being cleared. However, this may not be the case if external circuits change the voltage level on the pin. Check the status of the GPxINT registers before enabling the GPxIENA and GPxIENB interrupts initially, as well as any time the GPIOx pins are configured.

Interrupt bits are cleared by writing 1 to the appropriate bit location in GPxINT. Writing 0 has no effect. If interrupts are enabled to the core (GPxIENA, GPxIENB), an interrupt GPxINT value of 1 results in an interrupt to the core. Clear this GPxINT bit during servicing of the interrupt. When read as 1, a rising or falling edge (GPxPOL selectable) is detected on the corresponding GPIO pin. This bit can be software cleared by writing 1 to the appropriate GPxINT bit.

The following is example code to enable P1.1 as an input interrupt:

```
pADI_GPIO1->PE = 0x2;           // Enable internal pull-up resistors on P1.1
pADI_GPIO1->IE = 0x1;           // Enable P1.1 input path
pADI_GPIO1->IENA = 0x2;         // Enable External Interrupt A on P1.1
pADI_GPIO1->POL = 0x0;          // Interrupt on falling edge
NVIC_EnableIRQ(GPIO_INTA_IRQn); // Enable GPIO_INTA interrupt source in NVIC
```

DIGITAL INPUTS/OUTPUTS

The following is example code for a GPIO pin interrupt handler routine:

```
void GPIO_A_Int_Handler()
{
    unsigned int uiIntSta = 0;
    uiIntSta = pADI_GPIO1->INT;
    if ((uiIntSta & 0x2) == 0x2)    // interrupt expected on P1.1
    {
        pADI_GPIO1->INT |= 0x2;    // Clear the interrupt
    }
}
```

DIGITAL PORT MULTIPLEX

This block provides control over the GPIO functionality of specified pins because some of the pins offer the choice to work as a GPIO or to have other specific functions. Blank cells mean not applicable.

Table 204. GPIO Multiplex Table

GPIO	Configuration Modes			
	00	01	10	11
GP0CON Controls These Bits				
P0.0	GPIO (GP0CON[1:0] = 0x0)	SPI0 SCLK0 (GP0CON[1:0] = 0x1)	COMOUT0 (GP0CON[1:0] = 0x2)	PLAI0 (GP0CON[1:0] = 0x3)
P0.1	GPIO (GP0CON[3:2] = 0x0)	SPI0 MISO0 (GP0CON[3:2] = 0x1)	COMOUT1 (GP0CON[3:2] = 0x2)	PLAI1 (GP0CON[3:2] = 0x3)
P0.2	GPIO (GP0CON[5:4] = 0x0)	SPI0 MOSI0 (GP0CON[5:4] = 0x1)	PLACLK1 (GP0CON[5:4] = 0x2)	PLAI2 (GP0CON[5:4] = 0x3)
P0.3	GPIO/IRQ0 (GP0CON[7:6] = 0x0)	SPI0 CS0 (GP0CON[7:6] = 0x1)	PLACLK0 (GP0CON[7:6] = 0x2)	PLAI3 (GP0CON[7:6] = 0x3)
P0.4	GPIO (GP0CON[9:8] = 0x0)	I2C0 SCL0 (GP0CON[9:8] = 0x1)	UART0 SIN0 (GP0CON[9:8] = 0x2)	PLAO2 (GP0CON[9:8] = 0x3)
P0.5	GPIO (GP0CON[11:10] = 0x0)	I2C0 SDA0 (GP0CON[11:10] = 0x1)	UART0 SOUT0 (GP0CON[11:10] = 0x2)	PLAO3 (GP0CON[11:10] = 0x1)
P0.6	GPIO/IRQ3 (GP0CON[13:12] = 0x0)	I2C2 SCL2 (GP0CON[13:12] = 0x1)	COMPIN0 (GP0CON[11:10] = 0x2)	PLAO4 (GP0CON[13:12] = 0x3)
P0.7	GPIO/IRQ4 (GP0CON[15:14] = 0x0)	I2C2 SDA2 (GP0CON[15:14] = 0x1)	COMPIN1 (GP0CON[11:10] = 0x2)	PLAO[5] (GP0CON[15:14] = 0x3)
GP1CON Controls These Bits				
P1.0	GPIO (GP1CON[1:0] = 0x0)	UART1 SIN1 (GP1CON[1:0] = 0x1)	COMOUT2 (GP1CON[1:0] = 0x2)	PLAI4 (GP1CON[1:0] = 0x3)
P1.1	GPIO (GP1CON[3:2] = 0x0)	UART1 SOUT1 (GP1CON[3:2] = 0x1)	COMOUT3 (GP1CON[3:2] = 0x2)	PLAI5 (GP1CON[3:2] = 0x3)
P1.2	GPIO (GP1CON[5:4] = 0x0)	I2C1 SCL1 (GP1CON[5:4] = 0x1)	PWM0 (GP1CON[5:4] = 0x2)	PLAI6 (GP1CON[5:4] = 0x3)
P1.3	GPIO (GP1CON[7:6] = 0x0)	I2C1 SDA1 (GP1CON[7:6] = 0x1)	PWM1 (GP1CON[7:6] = 0x2)	PLAI7 (GP1CON[7:6] = 0x3)
P1.4	GPIO (GP1CON[9:8] = 0x0)	SPI1 SCLK1 (GP1CON[9:8] = 0x1)	PWM2 (GP1CON[9:8] = 0x2)	PLAO10 (GP1CON[9:8] = 0x3)
P1.5	GPIO (GP1CON[11:10] = 0x0)	SPI1 MISO1 (GP1CON[11:10] = 0x1)	PWM3 (GP1CON[11:10] = 0x2)	PLAO11 (GP1CON[11:10] = 0x3)
P1.6	GPIO (GP1CON[13:12] = 0x0)	SPI1 MOSI1 (GP1CON[13:12] = 0x1)	PWM4 (GP1CON[13:12] = 0x2)	PLAO12 (GP1CON[13:12] = 0x3)

DIGITAL INPUTS/OUTPUTS

Table 204. GPIO Multiplex Table (Continued)

GPIO	Configuration Modes			
	00	01	10	11
P1.7	GPIO/IRQ1 (GP1CON[15:14] = 0x0)	SPI1 $\overline{CS1}$ (GP1CON[15:14] = 0x1)	PWM5 (GP1CON[15:14] = 0x2)	PLAO13 (GP1CON[15:14] = 0x3)
GP2CON Controls These Bits				
P2.0	GPIO (GP2CON[1:0] = 0x0)	ADCCONV (GP2CON[1:0] = 0x1)	COMP2IN2 (GP2CON[1:0] = 0x2)	PLAI8 (GP2CON[1:0] = 0x3)
P2.1 ¹	GPIO/IRQ2 (GP2CON[3:2] = 0x0)	ECLKIN (GP2CON[3:2] = 0x1)	COMP2IN3 (GP2CON[3:2] = 0x2)	PLAI9 (GP2CON[3:2] = 0x3)
P2.2	GPIO (GP2CON[5:4] = 0x0)	POR (GP2CON[5:4] = 0x1)	CLKOUT (GP2CON[5:4] = 0x2)	SWO (GP2CON[5:4] = 0x3)
P2.3 ¹	GPIO/BM (GP2CON[7:6] = 0x0)			PLAI10 (GP2CON[7:6] = 0x3)
P2.4	GPIO (GP2CON[9:8] = 0x0)	SPI2 MOSI2 (GP2CON[9:8] = 0x1)		PLAO18 (GP2CON[9:8] = 0x3)
P2.5	GPIO (GP2CON[11:10] = 0x0)	SPI2 MISO2 (GP2CON[11:10] = 0x1)		PLAO19 (GP2CON[11:10] = 0x3)
P2.6	GPIO/IRQ5 (GP2CON[13:12] = 0x0)	SPI2 SCLK2 (GP2CON[13:12] = 0x1)		PLAO20 (GP2CON[13:12] = 0x3)
P2.7	GPIO/IRQ6 (GP2CON[15:14] = 0x0)	SPI2 $\overline{CS2}$ (GP2CON[15:14] = 0x1)		PLAO21 (GP2CON[15:14] = 0x3)
GP3CON Controls These Bits				
P3.0	GPIO/IRQ8 (GP3CON[1:0] = 0x0)	PRTADDR0 (GP3CON[1:0] = 0x1)	SRDY0 (GP3CON[1:0] = 0x2)	PLAI12 (GP3CON[1:0] = 0x3)
P3.1	GPIO (GP3CON[3:2] = 0x0)	PRTADDR1 (GP3CON[3:2] = 0x1)	PWMSYNC (GP3CON[3:2] = 0x2)	PLAI13 (GP3CON[3:2] = 0x3)
P3.2	GPIO (GP3CON[5:4] = 0x0)	PRTADDR2 (GP3CON[5:4] = 0x1)	PWMTRIP (GP3CON[5:4] = 0x2)	PLAI14 (GP3CON[5:4] = 0x3)
P3.3	GPIO (GP3CON[7:6] = 0x0)	PRTADDR3 (GP3CON[7:6] = 0x1)	UART0 SIN0 (GP3CON[7:6] = 0x2)	PLAI15 (GP3CON[7:6] = 0x3)
P3.4	GPIO/IRQ9 (GP3CON[9:8] = 0x0)	PRTADDR4 (GP3CON[9:8] = 0x1)	UART0 SOUT0 (GP3CON[9:8] = 0x2)	PLAO26 (GP3CON[9:8] = 0x3)
P3.5	GPIO (GP3CON[11:10] = 0x0)	MCK (GP3CON[11:10] = 0x1)	SRDY1 (GP3CON[11:10] = 0x2)	PLAO27 (GP3CON[11:10] = 0x3)
P3.6	GPIO (GP3CON[13:12] = 0x0)	MDIO (GP3CON[13:12] = 0x1)	SRDY2 (GP3CON[13:12] = 0x2)	PLAO30 (GP3CON[13:12] = 0x3)
P3.7	GPIO (GP3CON[15:14] = 0x0)			PLAO29 (GP3CON[15:14] = 0x3)
GP4CON Controls These Bits				
P4.0 ²	GPIO (GP4CON[1:0] = 0x0)	VDAC3 (GP4CON[1:0] = 0x1)		PLAI11 (GP4CON[1:0] = 0x3)
P4.1 ²	GPIO (GP4CON[3:2] = 0x0)	VDAC6 (GP4CON[3:2] = 0x1)		PLAO28 (GP4CON[1:0] = 0x3)
P4.2 ²	GPIO (GP4CON[5:4] = 0x0)	VDAC7 (GP4CON[5:4] = 0x1)		
P4.3 ²	GPIO (GP4CON[7:6] = 0x0)		PWM6 (GP4CON[7:6] = 0x2)	
P4.4 ²	GPIO (GP4CON[9:8] = 0x0)	VDAC5 (GP4CON[9:8] = 0x1)		
P4.5	GPIO (GP4CON[11:10] = 0x0)		PWM7 (GP4CON[11:10] = 0x2)	

DIGITAL INPUTS/OUTPUTS

Table 204. GPIO Multiplex Table (Continued)

GPIO	Configuration Modes			
	00	01	10	11
P4.7	GPIO/IRQ7 (GP4CON[15:14] = 0x0)		PLACK2 (GP4CON[15:14] = 0x2)	
GP5CON Controls These Bits				
P5.0 ²	GPIO (GP5CON[1:0] = 0x0)		VDAC8 (GP5CON[1:0] = 0x2)	
P5.1 ²	GPIO (GP5CON[3:2] = 0x0)		VDAC9 (GP5CON[3:2] = 0x2)	
P5.2 ²	GPIO (GP5CON[5:4] = 0x0)		VDAC10 (GP5CON[5:4] = 0x2)	
P5.3, ² P5.4, P5.5, P5.6	GPIO (GP5CON[7:6] = 0x0)		VDAC11 (GP5CON[7:6] = 0x2)	

¹ These pins do not retain their state after a reset.

² Never configure this pin as an output if the associated VDAC output is enabled.

REGISTER SUMMARY: DIGITAL INPUT/OUTPUT

Table 205. GPIO Register Summary

Address	Name	Description	Reset	Access
0x40050000	GP0CON	GPIO Port 0 Configuration.	0x0000	R/W
0x40050004	GP0OE	GPIO Port 0 Output Enable.	0x00	R/W
0x40050008	GP0IE	GPIO Port 0 Input Path Enable.	0x00	R/W
0x4005000C	GP0IN	GPIO Port 0 Registered Data Input.	0x00	R
0x40050010	GP0OUT	GPIO Port 0 Data Output.	0x00	R/W
0x40050014	GP0SET	GPIO Port 0 Data Out Set.	0x00	W
0x40050018	GP0CLR	GPIO Port 0 Data Out Clear.	0x00	W
0x4005001C	GP0TGL	GPIO Port 0 Pin Toggle.	0x00	W
0x40050020	GP0ODE	GPIO Port 0 Open-Drain Enable.	0x00	W
0x40050028	GP0PE	GPIO Port 0 Pull-Up/Pull-Down Enable.	0x00	R/W
0x4005002C	GP0PS	GPIO Port 0 Pull Select.	0xFF	R/W
0x40050030	GP0SR	GPIO Port 0 Slew Rate	0x00	R/W
0x40050034	GP0DS	GPIO Port 0 Drive Select.	0x0000	R/W
0x40050038	GP0PWR	GPIO Port 0 Power Select.	0x0F	R/W
0x4005003C	GP0POL	GPIO Interrupt Polarity Select.	0x00	R/W
0x40050040	GP0IENA	GPIO Port 0 Interrupt A Enable.	0x00	R/W
0x40050044	GP0IENB	GPIO Port 0 Interrupt B Enable.	0x00	R/W
0x40050048	GP0INT	GPIO Port 0 Interrupt Status.	0x00	R/W
0x40050050	GP1CON	GPIO Port 1 Configuration.	0x0000	R/W
0x40050054	GP1OE	GPIO Port 1 Output Enable.	0x00	R/W
0x40050058	GP1IE	GPIO Port 1 Input Path Enable.	0x00	R/W
0x4005005C	GP1IN	GPIO Port 1 Registered Data Input.	0x00	R
0x40050060	GP1OUT	GPIO Port 1 Data Output.	0x00	R/W
0x40050064	GP1SET	GPIO Port 1 Data Out Set.	0x00	W
0x40050068	GP1CLR	GPIO Port 1 Data Out Clear.	0x00	W
0x4005006C	GP1TGL	GPIO Port 1 Pin Toggle.	0x00	W
0x40050070	GP1ODE	GPIO Port 1 Open Drain Enable.	0x00	W
0x40050078	GP1PE	GPIO Port 1 Pull Enable.	0x00	R/W
0x4005007C	GP1PS	GPIO Port 1 Pull Select.	0xFF	R/W
0x40050080	GP1SR	GPIO Port 1 Slew Rate.	0x00	R/W

DIGITAL INPUTS/OUTPUTS

Table 205. GPIO Register Summary (Continued)

Address	Name	Description	Reset	Access
0x40050084	GP1DS	GPIO Port 1 Drive Select.	0x0000	R/W
0x40050088	GP1PWR	GPIO Port 1 Power Select.	0xFF	R/W
0x4005008C	GP1POL	GPIO Interrupt Polarity Select.	0x00	R/W
0x40050090	GP1IENA	GPIO Port 1 Interrupt A Enable.	0x00	R/W
0x40050094	GP1IENB	GPIO Port 1 Interrupt B Enable.	0x00	R/W
0x40050098	GP1INT	GPIO Port 1 Interrupt Status.	0x00	R/W
0x400500A0	GP2CON	GPIO Port 2 Configuration.	0x0010	R/W
0x400500A4	GP2OE	GPIO Port 2 Output Enable.	0x04	R/W
0x400500A8	GP2IE	GPIO Port 2 Input Path Enable.	0x0A	R/W
0x400500AC	GP2IN	GPIO Port 2 Registered Data Input.	0x0A	R
0x400500B0	GP2OUT	GPIO Port 2 Data Output.	0x00	R/W
0x400500B4	GP2SET	GPIO Port 2 Data Out Set.	0x00	W
0x400500B8	GP2CLR	GPIO Port 2 Data Out Clear.	0x00	W
0x400500BC	GP2TGL	GPIO Port 2 Pin Toggle.	0x00	W
0x400500C0	GP2ODE	GPIO Port 2 Open Drain Enable.	0x00	W
0x400500C8	GP2PE	GPIO Port 2 Pull Enable.	0x0A	R/W
0x400500CC	GP2PS	GPIO Port 2 Pull Select.	0xFD	R/W
0x400500D0	GP2SR	GPIO Port 2 Slew Rate.	0x00	R/W
0x400500D4	GP2DS	GPIO Port 2 Drive Select.	0x0000	R/W
0x400500DC	GP2POL	GPIO Interrupt Polarity Select.	0x00	R/W
0x400500E0	GP2IENA	GPIO Port 2 Interrupt A Enable.	0x00	R/W
0x400500E4	GP2IENB	GPIO Port 2 Interrupt B Enable.	0x00	R/W
0x400500E8	GP2INT	GPIO Port 2 Interrupt Status.	0x00	R/W
0x400500F0	GP3CON	GPIO Port 3 Configuration.	0x0000	R/W
0x400500F4	GP3OE	GPIO Port 3 Output Enable.	0x00	R/W
0x400500F8	GP3IE	GPIO Port 3 Input Path Enable.	0x00	R/W
0x400500FC	GP3IN	GPIO Port 3 Registered Data Input.	0x00	R
0x40050100	GP3OUT	GPIO Port 3 Data Output.	0x00	R/W
0x40050104	GP3SET	GPIO Port 3 Data Out Set.	0x00	W
0x0000108	GP3CLR	GPIO Port 3 Data Out Clear.	0x00	W
0x4005010C	GP3TGL	GPIO Port 3 Pin Toggle.	0x00	W
0x40050110	GP3ODE	GPIO Port 3 Open Drain Enable.	0x00	W
0x40050118	GP3PE	GPIO Port 3 Pull Enable.	0x00	R/W
0x4005011C	GP3PS	GPIO Port 3 Pull Select.	0xFF	R/W
0x40050120	GP3SR	GPIO Port 3 Slew Rate.	0x00	R/W
0x40050124	GP3DS	GPIO Port 3 Drive Select.	0x0000	R/W
0x4005012C	GP3POL	GPIO Interrupt Polarity Select.	0x00	R/W
0x40050130	GP3IENA	GPIO Port 3 Interrupt A Enable.	0x00	R/W
0x40050134	GP3IENB	GPIO Port 3 Interrupt B Enable.	0x00	R/W
0x40050138	GP3INT	GPIO Port 3 Interrupt Status.	0x00	R/W
0x40050140	GP4CON	GPIO Port 4 Configuration.	0x0000	R/W
0x40050144	GP4OE	GPIO Port 4 Output Enable.	0x00	R/W
0x40050148	GP4IE	GPIO Port 4 Input Path Enable.	0x00	R/W
0x4005014C	GP4IN	GPIO Port 4 Registered Data Input.	0x00	R
0x40050150	GP4OUT	GPIO Port 4 Data Output.	0x00	R/W
0x40050154	GP4SET	GPIO Port 4 Data Out Set.	0x00	W
0x40050158	GP4CLR	GPIO Port 4 Data Out Clear.	0x00	W
0x4005015C	GP4TGL	GPIO Port 4 Pin Toggle.	0x00	W
0x40050160	GP4ODE	GPIO Port 4 Open Drain Enable.	0x00	W

DIGITAL INPUTS/OUTPUTS

Table 205. GPIO Register Summary (Continued)

Address	Name	Description	Reset	Access
0x40050168	GP4PE	GPIO Port 4 Pull Enable.	0x00	R/W
0x4005016C	GP4PS	GPIO Port 4 Pull Select.	0xFF	R/W
0x40050170	GP4SR	GPIO Port 4 Slew Rate.	0x00	R/W
0x40050174	GP4DS	GPIO Port 4 Drive Select.	0x0000	R/W
0x4005017C	GP4POL	GPIO Interrupt Polarity Select.	0x00	R/W
0x40050180	GP4IENA	GPIO Port 4 Interrupt A Enable.	0x00	R/W
0x40050184	GP4IENB	GPIO Port 4 Interrupt B Enable.	0x00	R/W
0x40050188	GP4INT	GPIO Port 4 Interrupt Status.	0x00	R/W
0x40050190	GP5CON	GPIO Port 5 Configuration.	0x0000	R/W
0x40050194	GP5OE	GPIO Port 5 Output Enable.	0x00	R/W
0x40050198	GP5IE	GPIO Port 5 Input Path Enable.	0x00	R/W
0x4005019C	GP5IN	GPIO Port 5 Registered Data Input.	0x00	R
0x400501A0	GP5OUT	GPIO Port 5 Data Output.	0x00	R/W
0x400501A4	GP5SET	GPIO Port 5 Data Out Set.	0x00	W
0x400501A8	GP5CLR	GPIO Port 5 Data Out Clear.	0x00	W
0x400501AC	GP5TGL	GPIO Port 5 Pin Toggle.	0x00	W
0x400501B0	GP5ODE	GPIO Port 5 Open Drain Enable.	0x00	W
0x400501B8	GP5PE	GPIO Port 5 Pull Enable.	0x00	R/W
0x400501BC	GP5PS	GPIO Port 5 Pull Select.	0xFF	R/W
0x400501C0	GP5SR	GPIO Port 5 Slew Rate.	0x00	R/W
0x400501C4	GP5DS	GPIO Port 5 Drive Select.	0x0000	R/W
0x400501CC	GP5POL	GPIO Interrupt Polarity Select.	0x00	R/W
0x400501D0	GP5IENA	GPIO Port 5 Interrupt A Enable.	0x00	R/W
0x400501D4	GP5IENB	GPIO Port 5 Interrupt B Enable.	0x00	R/W
0x400501D8	GP5INT	GPIO Port 5 Interrupt Status.	0x00	R/W

REGISTER DETAILS: DIGITAL INPUT/OUTPUT

Note that not all bits are accessible to the user on a port. Inaccessible bits are reserved and must be ignored. See [Table 204](#) for more details on the accessible bits.

GPIO Port Configuration Register

Address: 0x40050000, Reset: See [Table 205](#), Name: GP0CON

Address: 0x40050050, Reset: See [Table 205](#), Name: GP1CON

Address: 0x400500A0, Reset: See [Table 205](#), Name: GP2CON

Address: 0x400500F0, Reset: See [Table 205](#), Name: GP3CON

Address: 0x40050140, Reset: See [Table 205](#), Name: GP4CON

Address: 0x40050190, Reset: See [Table 205](#), Name: GP5CON

Table 206. Bit Descriptions for GP0CON, GP1CON, GP2CON, GP3CON, GP4CON, and GP5CON

Bit(s)	Bit Name	Description ¹	Access
[15:14]	CON7	Configuration bits for Port x.7. See Table 204 .	RW
[13:12]	CON6	Configuration bits for Port x.6. See Table 204 .	RW
[11:10]	CON5	Configuration bits for Port x.5. See Table 204 .	RW
[9:8]	CON4	Configuration bits for Port x.4. See Table 204 .	RW
[7:6]	CON3	Configuration bits for Port x.3. See Table 204 .	RW
[5:4]	CON2	Configuration bits for Port x.2. See Table 204 .	RW
[3:2]	CON1	Configuration bits for Port x.1. See Table 204 .	RW

DIGITAL INPUTS/OUTPUTS

Table 206. Bit Descriptions for GP0CON, GP1CON, GP2CON, GP3CON, GP4CON, and GP5CON (Continued)

Bit(s)	Bit Name	Description ¹	Access
[1:0]	CON0	Configuration bits for Port x.0. See Table 204.	RW

¹ x is 0 for Port 0, 1 for Port 1, 2 for Port 2, 3 for Port 3, 4 for Port 4, and 5 for Port 5.

GPIO Port Output Enable Register

Address: 0x40050004, Reset: See Table 205, Name: GP0OE

Address: 0x40050054, Reset: See Table 205, Name: GP1OE

Address: 0x400500A4, Reset: See Table 205, Name: GP2OE

Address: 0x400500F4, Reset: See Table 205, Name: GP3OE

Address: 0x40050144, Reset: See Table 205, Name: GP4OE

Address: 0x40050194, Reset: See Table 205, Name: GP5OE

Table 207. Bit Descriptions for GP0OE, GP1OE, GP2OE, GP3OE, GP4OE, and GP5OE

Bits	Bit Name	Settings	Description	Reset	Access
[7:0]	OE		Pin Output Drive Enable.	0x0	RW
		0x0	Disable the output on the corresponding GPIO.		
		0x1	Enable the output on the corresponding GPIO.		

GPIO Port Input Path Enable Register

Address: 0x40050008, Reset: See Table 205, Name: GP0IE

Address: 0x40050058, Reset: See Table 205, Name: GP1IE

Address: 0x400500A8, Reset: See Table 205, Name: GP2IE (default value = 0x0A)

Address: 0x400500F8, Reset: See Table 205, Name: GP3IE

Address: 0x40050148, Reset: See Table 205, Name: GP4IE

Address: 0x40050198, Reset: See Table 205, Name: GP5IE

Table 208. Bit Descriptions for GP0IE, GP1IE, GP2IE, GP3IE, GP4IE, and GP5IE

Bits	Bit Name	Settings	Description	Reset	Access
[7:0]	IE		Input Path Enable.	0x0	RW
		0x0	Disable the output on the corresponding GPIO.		
		0x1	Enable the output on the corresponding GPIO.		

GPIO Port Registered Data Input

Address: 0x4005000C, Reset: See Table 205, Name: GP0IN

Address: 0x4005005C, Reset: See Table 205, Name: GP1IN

Address: 0x400500AC, Reset: See Table 205, Name: GP2IN (default value = 0x0A)

Address: 0x400500FC, Reset: See Table 205, Name: GP3IN

Address: 0x4005014C, Reset: See Table 205, Name: GP4IN

Address: 0x4005019C, Reset: See Table 205, Name: GP5IN

Table 209. Bit Descriptions for GP0IN, GP1IN, GP2IN, GP3IN, GP4IN, and GP5IN

Bit(s)	Bit Name	Description	Access
[7:0]	IN	Registered Data Input. Each bit reflects the state of the GPIO pin.	R

DIGITAL INPUTS/OUTPUTS**GPIO Port Data Output Register**

Address: 0x40050010, Reset: See [Table 205](#), Name: GP0OUT

Address: 0x40050060, Reset: See [Table 205](#), Name: GP1OUT

Address: 0x400500B0, Reset: See [Table 205](#), Name: GP2OUT

Address: 0x40050100, Reset: See [Table 205](#), Name: GP3OUT

Address: 0x40050150, Reset: See [Table 205](#), Name: GP4OUT

Address: 0x400501A0, Reset: See [Table 205](#), Name: GP5OUT

Table 210. Bit Descriptions for GP0OUT, GP1OUT, GP2OUT, GP3OUT, GP4OUT, and GP5OUT

Bits	Bit Name	Settings	Description	Reset	Access
[7:0]	OUT		Data Out.	0x0	RW
		0x0	Cleared by user to drive the corresponding GPIO low.		
		0x1	Set by user to drive the corresponding GPIO high.		

GPIO Port Data Out Set Register

Address: 0x40050014, Reset: See [Table 205](#), Name: GP0SET

Address: 0x40050064, Reset: See [Table 205](#), Name: GP1SET

Address: 0x400500B4, Reset: See [Table 205](#), Name: GP2SET

Address: 0x40050104, Reset: See [Table 205](#), Name: GP3SET

Address: 0x40050154, Reset: See [Table 205](#), Name: GP4SET

Address: 0x400501A4, Reset: See [Table 205](#), Name: GP5SET

Table 211. Bit Descriptions for GP0SET, GP1SET, GP2SET, GP3SET, GP4SET, and GP5SET

Bits	Bit Name	Settings	Description	Reset	Access
[7:0]	SET		Set the output high.	0x0	RW
		0x0	Clearing this bit has no effect.		
		0x1	Set by user code to drive the corresponding GPIO high.		

GPIO Port Data Out Clear Register

Address: 0x40050018, Reset: See [Table 205](#), Name: GP0CLR

Address: 0x40050068, Reset: See [Table 205](#), Name: GP1CLR

Address: 0x400500B8, Reset: See [Table 205](#), Name: GP2CLR

Address: 0x40050108, Reset: See [Table 205](#), Name: GP3CLR

Address: 0x40050158, Reset: See [Table 205](#), Name: GP4CLR

Address: 0x400501A8, Reset: See [Table 205](#), Name: GP5CLR

Table 212. Bit Descriptions for GP0CLR, GP1CLR, GP2CLR, GP3CLR, GP4CLR, and GP5CLR

Bits	Bit Name	Settings	Description	Reset	Access
[7:0]	CLR		Set the output to low.	0x0	RW
		0x0	Clearing this bit has no effect.		
		0x1	Each bit is set to drive the corresponding GPIO pin low.		

DIGITAL INPUTS/OUTPUTS**GPIO Port Pin Toggle Register**

Address: 0x4005001C, Reset: See [Table 205](#), Name: GP0TGL

Address: 0x4005006C, Reset: See [Table 205](#), Name: GP1TGL

Address: 0x400500BC, Reset: See [Table 205](#), Name: GP2TGL

Address: 0x4005010C, Reset: See [Table 205](#), Name: GP3TGL

Address: 0x4005015C, Reset: See [Table 205](#), Name: GP4TGL

Address: 0x400501AC, Reset: See [Table 205](#), Name: GP5TGL

Table 213. Bit Descriptions for GP0TGL, GP1TGL, GP2TGL, GP3TGL, GP4TGL, and GP5TGL

Bits	Bit Name	Settings	Description	Reset	Access
[7:0]	TGL		Toggle the output of the port pin.	0x0	RW
		0x0	Clearing this bit has no effect.		
		0x1	Set by user code to invert the corresponding GPIO pin.		

GPIO Port Open Drain Enable Register

Address: 0x40050020, Reset: See [Table 205](#), Name: GP0ODE

Address: 0x40050070, Reset: See [Table 205](#), Name: GP1ODE

Address: 0x400500C0, Reset: See [Table 205](#), Name: GP2ODE

Address: 0x40050110, Reset: See [Table 205](#), Name: GP3ODE

Address: 0x40050160, Reset: See [Table 205](#), Name: GP4ODE

Address: 0x400501B0, Reset: See [Table 205](#), Name: GP5ODE

Table 214. Bit Descriptions for GP0ODE, GP1ODE, GP2ODE, GP3ODE, GP4ODE, and GP5ODE

Bits	Bit Name	Settings	Description	Reset	Access
[7:0]	ODE		Open-Drain Enable.	0x0	RW
		0x0	Set output mode to push-pull for corresponding GPIO pin.		
		0x1	Set output mode to open drain for corresponding GPIO pin.		

GPIO Port Pull-Up Enable Register

Address: 0x40050028, Reset: See [Table 205](#), Name: GP0PE

Address: 0x40050074, Reset: See [Table 205](#), Name: GP1PE

Address: 0x400500C4, Reset: See [Table 205](#), Name: GP2PE (default value = 0x0A)

Address: 0x40050118, Reset: See [Table 205](#), Name: GP3PE

Address: 0x40050168, Reset: See [Table 205](#), Name: GP4PE

Address: 0x400501B8, Reset: See [Table 205](#), Name: GP5PE

Table 215. Bit Descriptions for GP0PE, GP1PE, GP2PE, GP3PE, GP4PE, and GP5PE

Bits	Bit Name	Settings	Description	Reset	Access
[7:0]	PE		Pull-Up Operation Enable in input mode.	0x0	RW
		0x0	Disable the pull-up operation on the corresponding GPIO.		
		0x1	Enable the pull-up operation on the corresponding GPIO.		

DIGITAL INPUTS/OUTPUTS**GPIO Port Pull Up/Down Register**

Address: 0x4005002C, Reset: See [Table 205](#), Name: GP0PS

Address: 0x4005007C, Reset: See [Table 205](#), Name: GP1PS

Address: 0x400500CC, Reset: See [Table 205](#), Name: GP2PS (default value = 0xFD)

Address: 0x4005011C, Reset: See [Table 205](#), Name: GP3PS

Address: 0x4005016C, Reset: See [Table 205](#), Name: GP4PS

Address: 0x400501BC, Reset: See [Table 205](#), Name: GP5PS

Table 216. Bit Descriptions for GP0PS, GP1PS, GP2PS, GP3PS, GP4PS, and GP5PS

Bits	Bit Name	Settings	Description	Reset	Access
[7:0]	PS		Pull-Up/Down Selection Input Mode.	0xFF	R/W
		0x0	Select pull-down on the corresponding GPIO.		
		0x1	Select pull-up on the corresponding GPIO.		

GPIO Port Slew Rate Register

Address: 0x40050030, Reset: See [Table 205](#), Name: GP0SR

Address: 0x40050080, Reset: See [Table 205](#), Name: GP1SR

Address: 0x400500D0, Reset: See [Table 205](#), Name: GP2SR

Address: 0x40050120, Reset: See [Table 205](#), Name: GP3SR

Address: 0x40050170, Reset: See [Table 205](#), Name: GP4SR

Address: 0x400201C0, Reset: See [Table 205](#), Name: GP5SR

Table 217. Bit Descriptions for GP0SR, GP1SR, GP2SR, GP3SR, GP4SR, and GP5SR

Bits	Bit Name	Settings	Description	Reset	Access
[7:0]	SR		Slew Rate Selection.	0x0	R/W
		0x0	Fast slew rate.		
		0x1	Slow slew rate.		

GPIO Port Drive Select Register

Address: 0x40050034, Reset: See [Table 205](#), Name: GP0DS

Address: 0x40050084, Reset: See [Table 205](#), Name: GP0DS

Address: 0x400500D4, Reset: See [Table 205](#), Name: GP2DS

Address: 0x40050124, Reset: See [Table 205](#), Name: GP3DS

Address: 0x40050174, Reset: See [Table 205](#), Name: GP4DS

Address: 0x400501C4, Reset: See [Table 205](#), Name: GP5DS

Table 218. Bit Descriptions for GP0DS, GP1DS, GP2DS, GP3DS, GP4DS, and GP5DS

Bits	Bit Name	Settings	Description	Reset	Access
[15:14]	DS7		Pin x.7 Drive Strength.	0x0	R/W
[13:12]	DS6		Pin x.6 Drive Strength.	0x0	R/W
[11:10]	DS5		Pin x.5 Drive Strength.	0x0	R/W
[9:8]	DS4		Pin x.4 Drive Strength.	0x0	R/W
[7:6]	DS3		Pin x.3 Drive Strength.	0x0	R/W

DIGITAL INPUTS/OUTPUTS

Table 218. Bit Descriptions for GP0DS, GP1DS, GP2DS, GP3DS, GP4DS, and GP5DS (Continued)

Bits	Bit Name	Settings	Description	Reset	Access
[5:4]	DS2		Pin x.2 Drive Strength.	0x0	R/W
[3:2]	DS1		Pin x.1 Drive Strength.	0x0	R/W
[1:0]	DS0		Pin x.0 Drive Strength.	0x0	R/W

GPIO Port Power Select Register

Address: 0x40050038, Reset: See Table 205, Name: GP0PWR

Table 219. Bit Descriptions for GP0PWR

Bits	Bit Name	Settings	Description	Reset	Access
[7:4]	Reserved		Reserved	0x0	R/W
[3:0]	PWR		Port 0.3 to Port 0.0 Power Select.	0xF	R/W
		0x0	Low power 1.2 V or 1.8 V by default. (IOVDD1 rail selected).		
		0x1	Enable high power supply 3.3 V. (IOVDD0 rail selected).		

Address: 0x40050088, Reset: See Table 205, Name: GP1PWR

Table 220. Bit Descriptions for GP1PWR

Bits	Bit Name	Settings	Description	Reset	Access
[7:0]	PWR		Port 1.x Power Select.	0x0	R/W
		0x0	Low power 1.2 V or 1.8 V by default (IOVDD1 rail selected).		
		0x1	Enable high power supply 3.3 V (IOVDD0 rail selected).		

GPIO Port Interrupt Polarity Select Register

Address: 0x4005003C, Reset: 0x0000, Name: GP0POL

Address: 0x4005008C, Reset: 0x0000, Name: GP1POL

Address: 0x400500DC, Reset: 0x0000, Name: GP2POL

Address: 0x4005012C, Reset: 0x0000, Name: GP3POL

Address: 0x4005017C, Reset: 0x0000, Name: GP4POL

Address: 0x400501CC, Reset: 0x0000, Name: GP5POL

Table 221. Bit Descriptions for GP0POL, GP1POL, GP2POL, GP3POL, GP4POL, and GP5POL

Bits	Bit Name	Settings	Description	Access
[7:0]	POL		GPIO Pin Interrupt Polarity Control.	R/W
		0	Clear this bit for pin interrupts triggered on a high to low transition.	
		1	Set this bit for pin interrupts triggered on a low to high transition.	

GPIO Port Interrupt A Enable Registers

Address: 0x40050040, Reset: 0x00, Name: GP0IENA

Address: 0x40050090, Reset: 0x00, Name: GP1IENA

Address: 0x400500E0, Reset: 0x00, Name: GP2IENA

Address: 0x40050130, Reset: 0x00, Name: GP3IENA

Address: 0x40050180, Reset: 0x00, Name: GP4IENA

Address: 0x400501D0, Reset: 0x00, Name: GP5IENA

DIGITAL INPUTS/OUTPUTS

Table 222. Bit Descriptions for GP0IENA, GP1IENA, GP2IENA, GP3IENA, GP4IENA, GP5IENA

Bits	Bit Name	Settings	Description	Access
[7:0]	INTAEN		GPIO Pin Interrupt A Enable Register. 0 Clear this bit to disable the corresponding pin interrupt. 1 Set this bit to enable the corresponding pin interrupt.	R/W

GPIO Port Interrupt B Enable Registers

Address: 0x40050044, Reset: 0x00, Name: GP0IENB

Address: 0x40050094, Reset: 0x00, Name: GP1IENB

Address: 0x400500E4, Reset: 0x00, Name: GP2IENB

Address: 0x40050134, Reset: 0x00, Name: GP3IENB

Address: 0x40050184, Reset: 0x00, Name: GP4IENB

Address: 0x400501D4, Reset: 0x00, Name: GP5IENB

Table 223. Bit Descriptions for GP0IENB, GP1IENB, GP2IENB, GP3IENB, GP4IENB, GP5IENB

Bits	Bit Name	Settings	Description	Access
[7:0]	INTBEN		GPIO Pin Interrupt B Enable Register. 0 Clear this bit to disable the corresponding pin interrupt. 1 Set this bit to enable the corresponding pin interrupt.	R/W

GPIO Port Interrupt Status Registers

Address: 0x40050048, Reset: 0x00, Name: GP0INT

Address: 0x40050098, Reset: 0x00, Name: GP1INT

Address: 0x400500E8, Reset: 0x00, Name: GP2INT

Address: 0x40050138, Reset: 0x00, Name: GP3INT

Address: 0x40050188, Reset: 0x00, Name: GP4INT

Address: 0x400501D8, Reset: 0x00, Name: GP5INT

Table 224. Bit Descriptions for GP0INT, GP1INT, GP2INT, GP3INT, GP4INT, and GP5INT

Bits	Bit Name	Settings	Description	Access
[7:0]	INTSTATUS		GPIO Pin Interrupt Status Register. 0 Indicates no interrupt on corresponding pin. 1 When set, this bit indicates the corresponding pin interrupt event has been latched. To clear this bit and interrupt event, write 1 to the same bit. Writing 0 has no effect.	R/W1C

GENERAL-PURPOSE TIMERS (16-BIT)

The ADuCM410 and ADuCM420 have three 16-bit general-purpose timers. For information about the 32-bit timers, see the [General-Purpose Timers \(32-Bit\)](#) section.

The three 16-bit general-purpose timers, GPT0, GPT1, and GPT2, are identical in their operation. They can be configured as count up or count down timers.

TIMER FEATURES AND OVERVIEW

The clock sources of the general-purpose timers include the following:

- ▶ PCLK0
- ▶ System clock (SYSCLK)
- ▶ 32 kHz low frequency oscillator
- ▶ Analog root clock (selected by CLKCON0, Bits[11:10])

The selected input clock source can be divided by a prescaler factor of 1, 4, 16, 256, or 32768, as set by CON, Bits[1:0].

The timers can be configured in free running or periodic modes. In free running mode, the counter decrements from full scale to zero scale, or increments from zero scale to full scale, and then restarts. In periodic mode, the counter decrements or increments from the value in the load register (LD) until zero scale or full scale is reached, and then restarts at the value stored in the load register.

The value of a counter can be read at any time by accessing its value register (VAL).

The CON register selects the timer mode, configures the clock source, selects count up or count down, and starts the counter.

An interrupt signal is generated each time the value of the counter reaches 0 when counting down, or each time the counter value reaches the maximum value when counting up. An IRQ can be cleared by writing 1 to the time clear interrupt register of that particular timer (CLRI).

GENERAL-PURPOSE TIMERS OPERATION

Free Running Mode

In free running mode, the timer is started by setting the enable bit (CON, Bit 4) to 1 and the MOD bit (CON, Bit 3) to 0. The timer increments from zero scale to full scale if counting up or full scale to zero scale if counting down. Full scale is $2^{16} - 1$, or 0xFFFF in hexadecimal format. Upon reaching full scale (or zero scale), a timeout interrupt occurs and STA, Bit 0 is set. To clear the timer interrupt, user code must write 1 to CLRI, Bit 0. If CON, Bit 7 is set, the timer keeps counting and reloads when the CLRI register is written.

Periodic Mode

In periodic mode, the initial LD value must be loaded before starting the timer by setting the enable bit (CON, Bit 4) to 1. The timer value either increments from the value in LD to full scale or decrements from the value in LD to zero scale, depending on the CON, Bit 2 settings (count up or count down). Upon reaching full scale or zero scale, the timer generates an interrupt. The LD is reloaded into VAL, and the timer continues counting up or down. The timer must be disabled prior to changing the CON or LD register. If the LD register is changed while the timer is being loaded, undefined results may occur. By default, the counter is reloaded automatically when generating the interrupt signal. If CON, Bit 7 is set to 1, the counter is also reloaded when user code writes 1 to CLRI, which allows user changes to the LD to take effect immediately instead of waiting until the next timeout.

The timer interval is calculated as follows:

If the timer is set to count down,

$$\text{Interval} = (\text{LD} \times \text{Prescaler}) / \text{Source Clock} \quad (27)$$

For example, if LD = 0x100, Prescaler = 4, and Source Clock = SYSCLK, the interval is 6.4 μ s (where UCLK = 160 MHz).

If the timer is set to count up,

$$\text{Interval} = ((\text{Full Scale} - \text{LD}) \times \text{Prescaler}) / \text{Source Clock} \quad (28)$$

GENERAL-PURPOSE TIMERS (16-BIT)**Asynchronous Clock Source**

Timers are started by setting the enable bit (CON, Bit 4) to 1 in the control register of the corresponding timer.

However, when the timer clock source is the 32 kHz low frequency oscillator, the following precautions must be taken:

- ▶ Do not write to the control register (CON) if STA, Bit 6 is set. Therefore, STA must be read prior to configuring the control register (CON). When STA, Bit 6 is cleared, the register can be modified, ensuring that synchronizing the timer control between the processor and the timer clock domains is complete. STA, Bit 6 is the timer busy status bit.
- ▶ After clearing the interrupt in CLRI, ensure that the register write has completed before returning from the interrupt handler. Use the data synchronization barrier (DSB) instruction if necessary and check that STA, Bit 7 = 0.

```
asm void asmDSB()
{
  nop
  DSB
  BX LR
}
```

- ▶ The value of a counter can be read at any time by accessing its value register (VAL). In an asynchronous configuration, VAL must always be read twice. If the two readings are different, it must be read a third time to determine the correct value.

STA must be read prior to writing to any timer register after setting or clearing the enable bit. When STA, Bit 7 is cleared, registers can be modified, which ensures that the timer has completed synchronization between the processor and the timer clock domains. The typical synchronization time is two timer clock periods.

REGISTER SUMMARY: GENERAL-PURPOSE TIMERS

GPT0 base address: 0x40000000

GPT1 base address: 0x40000400

GPT2 base address: 0x40000800

Table 225. Timer Register Summary

Address	Name	Description	Reset	Access
Base Address + 0x00	LD	16-Bit Load Value Register.	0x0000	R/W
Base Address + 0x04	VAL	16-Bit Timer Value Register.	0x0000	R
Base Address + 0x08	CON	Control Register.	0x000A	R/W
Base Address + 0x0C	CLRI	Clear Interrupt Register.	0x0000	R/W
Base Address + 0x1C	STA	Status Register.	0x0000	R

REGISTER DETAILS: GENERAL-PURPOSE TIMERS**16-Bit Load Value Register**

Address: Base Address + 0x00, Reset: 0x0000, Name: LD

Table 226. Bit Descriptions for LD

Bits	Bit Name	Settings	Description	Reset	Access
[15:0]	LOAD		Load Value. The up or down counter is periodically loaded with this value. If periodic mode is selected (CON, Bit 3 = 1), Load[15:0] writes during up or down counter timeout events are delayed until the event has passed.	0x0	R/W

GENERAL-PURPOSE TIMERS (16-BIT)**16-Bit Timer Value Register**

Address: Base Address + 0x04, Reset: 0x0000, Name: VAL

Table 227. Bit Descriptions for VAL

Bits	Bit Name	Settings	Description	Reset	Access
[15:0]	COUNT_VAL		Current Count. Reflects the current up or down counter value. This value is delayed two PCLK0 cycles due to clock synchronizers.	0x0	R

Control Register

Address: Base Address + 0x08, Reset: 0x000A, Name: CON

Table 228. Bit Descriptions for CON

Bits	Bit Name	Settings	Description	Reset	Access
[15:8]	RESERVED		Reserved.	0x0	R
7	RLD		Reload Control. RLD is only used for periodic mode. This bit allows the user to select whether the up or down counter is reset only on a timeout event or also when CLRI, Bit 0 is set. 1 Resets the Up/Down Counter when CLRI, Bit 0 is Set. 0 Up/Down Counter is Only Reset on a Timeout Event.	0x0	R/W
[6:5]	CLK		Clock Select. Used to select a timer clock from the four available clock sources. 00 PCLK0. 01 SYSCLK. 10 Low Frequency 32 kHz Oscillator. 11 16 MHz Oscillator.	0x0	R/W
4	ENABLE		Timer Enable. Used to enable and disable the timer. Clearing this bit resets the timer, including the TVAL register. 0 Timer is Disabled (default). 1 Timer is Enabled.	0x0	R/W
3	MOD		Timer Mode. This bit is used to control whether the timer runs in periodic or free running mode. In periodic mode, the up or down counter starts at the defined Load[15:0] value. In free running mode, the up or down counter starts at 0x0000 or 0xFFFF depending on whether the timer is counting up or down. 0 Free Run. Timer Runs in Free Running Mode. 1 Periodic. Timer Runs in Periodic Mode (Default).	0x1	R/W
2	UP		Count Up. Used to control whether the timer increments (counts up) or decrements (counts down) the up or down counter. 0 Timer is Set to Count Down (Default). 1 Timer is Set to Count Up.	0x0	R/W
[1:0]	PRE		Prescaler. Controls the prescaler division factor applied to the selected clock of the timer. If PCLK or SYSCLK is selected as the timer clock source, prescaler value of 0 means divide by 4. Else, it means divide by 1. 00 Source Clock/1 or Source Clock/4. 01 Source Clock/16. 10 Source Clock/256. 11 Source Clock/32,768.	0x2	R/W

Clear Interrupt Register

Address: Base Address + 0x0C, Reset: 0x0000, Name: CLRI

Table 229. Bit Descriptions for CLRI

Bits	Bit Name	Settings	Description	Reset	Access
[15:1]	RESERVED		Reserved.	0x0	R
0	TMOUT		Clear Timeout Interrupt. This bit is used to clear a timeout interrupt.	0x0	R/W1C

GENERAL-PURPOSE TIMERS (16-BIT)**Status Register**

Address: Base Address + 0x1C, Reset: 0x0000, Name: STA

Table 230. Bit Descriptions for STA

Bits	Bit Name	Settings	Description	Reset	Access
[15:8]	RESERVED		Reserved.	0x0	R
7	PDOK		CLRI Synchronization. This bit is set automatically when the user sets CLRI, Bit 0 = 1. It is cleared automatically when the clear interrupt request has crossed clock domains and taken effect in the timer clock domain. 0 Clear. The Interrupt is Cleared in the Timer Clock Domain. 1 Set. CLRI, Bit 0 is Being Updated in the Timer Clock Domain.	0x0	R
6	BUSY		Timer Busy. This bit informs the user that a write to CON is still crossing into the timer clock domain. Check this bit after writing CON, and suppress further writes until this bit is cleared. 0 Timer Ready to Receive Commands to CON. 1 Timer Not Ready to Receive Commands to CON.	0x0	R
[5:1]	RESERVED		Reserved.	0x0	R
0	TMOUT		Timeout Event Occurred. This bit is set automatically when the value of the counter reaches zero while counting down or reaches full scale when counting up. This bit is cleared when CLRI, Bit 0 is set by the user. 0 No Timeout Event Has Occurred. 1 A Timeout Event Has Occurred.	0x0	R

GENERAL-PURPOSE TIMERS (32-BIT)

The two 32-bit general-purpose timers are basic 32-bit counters with an overflow interrupt. They are intended to be used as a long-term time counter within a system. Their clock source is programmable. These two timers only support counting upward. Also, they only support free running mode. Periodic mode is not supported.

TIMER COMPARE FEATURE

To use the timer as a normal timer with interrupts, use the compare function. An interrupt can be generated when the count value register matches a selected compare value register.

TIMER CAPTURE FEATURE

The capture feature is used to timestamp an interrupt event from another peripheral.

The event for each timer is selectable via the EVENT_SEL bits in the CFGx registers of each timer. For example, if the Timer 0 CFG0 event bits are configured to select the ADC as its interrupt source, the 32-bit count value of Timer 0 is loaded into the CC0 register when an ADC interrupt occurs.

The captured value in the CCx register holds its value and cannot be overwritten until the associated status bit is cleared. To clear an associated status, write 1 to it.

The following example instructions show how to configure the ADC as the capture channel for 32-bit Timer 0:

```
void Init32BitTimers(void)
{
    pADI_GPTH0->CFG0 = BITP_TIMER_CFG_N_CC_EN | // Capture enabled
                    BITM_TIMER_CFG_N_CC_EN | // Capture/Compare enabled
                    0x20;                    // Capture ADC Event

    pADI_GPTH0->CTL = 0x5;                    // Start 32-bit Timer0 with /1
    NVIC_EnableIRQ(GPT3_IRQn);              // enable 32-bit T0 IRQ
}
void GP_Tmr3_Int_Handler()
{
    if (( pADI_GPTH0->STATUS & 0x1) == 0x1) // Check that the Capture bit0 is set
    {
        uiADCTime = pADI_GPTH0->CC0;        // Read the Capture value
        pADI_GPTH0->STATUS = 0x1;           // Clear the Capture status flag
    }
}
```

Table 231. 32-Bit Timers Event Capture Selection Table

EVENT_SEL Bits (Decimal)	GPT0 Capture Source	GPT1 Capture Source
0	Analog Comparator 2	External Interrupt 8
1	Analog Comparator 3	External Interrupt 7
2	SPI1	DMA done (any)
3	MDIO	MDIO
4	Flash	Flash
5	Cache	Cache
6	SRAM	Reserved
7	PWMTRIP	Reserved
8	ADC	Digital comparator (any)
9	ADC sequencer	External Interrupt 0
10	Reserved	External Interrupt 1
11	Reserved	External Interrupt 2
12	SPI2	Reserved
13	32-bit Timer 1	SPI2

GENERAL-PURPOSE TIMERS (32-BIT)

Table 231. 32-Bit Timers Event Capture Selection Table (Continued)

EVENT_SEL Bits (Decimal)	GPT0 Capture Source	GPT1 Capture Source
14	Digital comparator (any)	SPI1
15	GPT0	SPI0

REGISTER SUMMARIES: 32-BIT TIMER 0 AND 32-BIT TIMER 1

Table 232. Timer 0 Register Summary

Address	Name	Description	Reset	Access
0x4000C00	CTL	Timer Control.	0x00000170	R/W
0x4000C04	CNT	Count Value.	0x00000000	R/W
0x4000C08	STATUS	Timer Status.	0x00000000	R/W
0x4000C10	CFG0	Capture Compare Configuration 0.	0x00000000	R/W
0x4000C14	CFG1	Capture Compare Configuration 1.	0x00000000	R/W
0x4000C18	CFG2	Capture Compare Configuration 2.	0x00000000	R/W
0x4000C1C	CFG3	Capture Compare Configuration 3.	0x00000000	R/W
0x4000C20	CC0	Compare and Capture Value 0.	0x00000000	R/W
0x4000C24	CC1	Compare and Capture Value 1.	0x00000000	R/W
0x4000C28	CC2	Compare and Capture Value 2.	0x00000000	R/W
0x4000C2C	CC3	Compare and Capture Value 3.	0x00000000	R/W

Table 233. Timer 1 Register Summary

Address	Name	Description	Reset	Access
0x40001000	CTL	Timer Control.	0x00000170	R/W
0x40001004	CNT	Count Value.	0x00000000	R/W
0x40001008	STATUS	Timer Status.	0x00000000	R/W
0x40001010	CFG0	Capture Compare Configuration 0.	0x00000000	R/W
0x40001014	CFG1	Capture Compare Configuration 1.	0x00000000	R/W
0x40001018	CFG2	Capture Compare Configuration 2.	0x00000000	R/W
0x4000101C	CFG3	Capture Compare Configuration 3.	0x00000000	R/W
0x40001020	CC0	Compare and Capture Value 0.	0x00000000	R/W
0x40001024	CC1	Compare and Capture Value 1.	0x00000000	R/W
0x40001028	CC2	Compare and Capture Value 2.	0x00000000	R/W
0x4000102C	CC3	Compare and Capture Value 3.	0x00000000	R/W

REGISTER DETAILS: 32-BIT TIMER 0 AND 32-BIT TIMER 1

Timer Control 0 and Timer Control 1 Registers

Timer 0: Address: 0x4000C00, Reset: 0x00000170, Name: CTL

Timer 1: Address: 0x40001000, Reset: 0x00000170, Name: CTL

Table 234. Bit Descriptions for CTL

Bits	Bit Name	Settings	Description	Reset	Access
[31:9]	RESERVED		Reserved.	0x0	R
[8:4]	PRE		Clock Prescaler. The input clock of the timer is divided by this value + 1. The default value of 23 provides a divide by 24. Therefore, a 24 MHz clock results in a 1 μ s timer tick. A setting of 0 provides divide by 1, and a setting of 31 provides divide by 32. This setting cannot be changed while the timer is enabled. Write attempts to modify this value while the timer is enabled are ignored. This value can be modified in the same cycle when the timer is enabled or disabled.	0x17	R/W
[3:2]	SEL		Clock Source Select. This field sets the source for the timer clock. Timer clock source can only be changed while the timer is disabled. If the timer clock source is written while the timer is enabled, the write is ignored. The timer clock source can be changed simultaneously on the same cycle that the timer is enabled or disabled but is ignored if the timer is currently enabled and the write leaves it enabled.	0x0	R/W

GENERAL-PURPOSE TIMERS (32-BIT)**Table 234. Bit Descriptions for CTL (Continued)**

Bits	Bit Name	Settings	Description	Reset	Access
		00	PCLK0.		
		01	SYSCLK.		
		10	High Frequency Oscillator (16 MHz).		
		11	Reserved.		
1	RESERVED		Reserved.	0x0	R
0	EN		Timer Enable. This bit enables the timer counter. Set to 1 to enable the timer.	0x0	R/W

Count Value 0 and Count Value 1 Registers

Timer 0: Address: 0x40000C04, Reset: 0x00000000, Name: CNT

Timer 1: Address: 0x40001004, Reset: 0x00000000, Name: CNT

Table 235. Bit Descriptions for CNT

Bits	Bit Name	Settings	Description	Reset	Access
[31:0]	CNT		Current Counter Value. This register is incremented once every timer tick. Writes to this register are buffered and only written to the counter when the timer is enabled, and the clock source is running. If the timer is enabled and this register is written, it is buffered until the next timer clock edge. If another write to the counter occurs while a write is pending and the timer is enabled, the write returns a bus error. If the timer counter is written multiple times while the timer is disabled, only the last write is buffered and pending (to be committed to the counter when the timer is enabled). This register rolls over from $2^{32} - 1$ to 0.	0x0	R/W

Timer Status 0 and Timer Status 1 Registers

Timer 0: Address: 0x40000C08, Reset: 0x00000000, Name: STATUS

Timer 1: Address: 0x40001008, Reset: 0x00000000, Name: STATUS

Table 236. Bit Descriptions for STATUS

Bits	Bit Name	Settings	Description	Reset	Access
[31:4]	RESERVED		Reserved.	0x0	R
3	CC3_STATUS		CC3 Status. In capture mode (mode bit in CFG3 = 1), CC3_STATUS indicates the selected event is captured. In compare mode (mode bit in CFG3 = 0), CC3_STATUS indicates the counter has passed the CC3 value ($CNT - CC3 \leq 0$). This bit is cleared when written with 1, if the CC3 register is written, or if the timer is disabled.	0x0	R/W
2	CC2_STATUS		CC2 Status. In capture mode (mode bit in CFG2 = 1), CC2_STATUS indicates the selected event is captured. In compare mode (mode bit in CFG2 = 0), CC2_STATUS indicates the counter has passed the CC2 value ($CNT - CC2 \leq 0$). This bit is cleared when written with 1, if the CC2 register is written, or if the timer is disabled.	0x0	R/W
1	CC1_STATUS		CC1 Status. In capture mode (mode bit in CFG1 = 1), CC1_STATUS indicates the selected event is captured. In compare mode (mode bit in CFG1 = 0), CC1_STATUS indicates the counter has passed the CC1 value ($CNT - CC1 \leq 0$). This bit is cleared when written with 1, if the CC2 register is written, or if the timer is disabled.	0x0	R/W
0	CC0_STATUS		CC0 Status. In capture mode (mode bit in CFG0 = 1), CC0_STATUS indicates the selected event is captured. In compare mode (mode bit in CFG0 = 0), CC0_STATUS indicates the counter has passed the CC0 value ($CNT - CC0 \leq 0$). This bit is cleared when written with 1, if the CC2 register is written, or if the timer is disabled.	0x0	R/W

GENERAL-PURPOSE TIMERS (32-BIT)**Compare Configuration 0 and Compare Configuration 1 Registers**

Timer 0: Address: 0x40000C10 to 0x40000C1C (Increments of 0x04), Reset: 0x00000000, Name: CFGx (for x = 0 to 3)

Timer 1: Address: 0x40001010 to 0x4000101C (Increments of 0x04), Reset: 0x00000000, Name: CFGx (for x = 0 to 3)

Table 237. Bit Descriptions for CFG0 to CFG3

Bits	Bit Name	Settings	Description	Reset	Access
[31:6]	RESERVED		Reserved.	0x0	R
[5:2]	EVENT_SEL		Capture Events Select. Each CCx can select only one capture event from the 16-bit capture event bus. The value of EVENT_SEL decides which capture event is selected. Capture Event 0 to Capture Event 3 are connected to Compare Event 0 to Compare Event 3, respectively, of the other timer. Capture Event 4 and Capture Event 5 are connected to GPIO Interrupt 0 and Interrupt 1, respectively.	0x0	R/W
1	CC_EN		Capture Compare Enabled.	0x0	R/W
0	MODE		Capture or Compare Mode. 0 Compare. 1 Capture.	0x0	R/W

Compare Value 0 and Compare Value 1 Registers

Timer 0: Address: 0x40000C20 to 0x40000C2C (Increments of 0x04), Reset: 0x00000000, Name: CCx (for x = 0 to 3)

Timer 1: Address: 0x40001020 to 0x4000102C (Increments of 0x04), Reset: 0x00000000, Name: CCx (for x = 0 to 3)

Table 238. Bit Descriptions for CCx (for x = 0 to 3)

Bits	Bit Name	Settings	Description	Reset	Access
[31:0]	CC		Compare Value. This field holds the compare value that generates the compare event. Comparison is signed. Therefore, if written with a value that has occurred in the past, an interrupt is generated immediately. Compare value can be set to generate an interrupt up to $2^{31} - 1$ timer clock cycles into the future and generate an interrupt immediately if the count has occurred up to 2^{31} cycles in the past.	0x0	R/W

WAKE-UP TIMER

WAKE-UP TIMER FEATURES

The wake-up timer features for the ADuCM410 and ADuCM420 include the following:

- ▶ 32-bit counter (count down or count up)
- ▶ Three clock sources with programmable prescaler (1, 16, 256, or 32768)
 - ▶ Peripheral clock (PCLK0)
 - ▶ 32 kHz internal low frequency oscillator
 - ▶ External clock (ECLKIN)
- ▶ Four compare points, one automatic increment

WAKE-UP TIMER BLOCK DIAGRAM

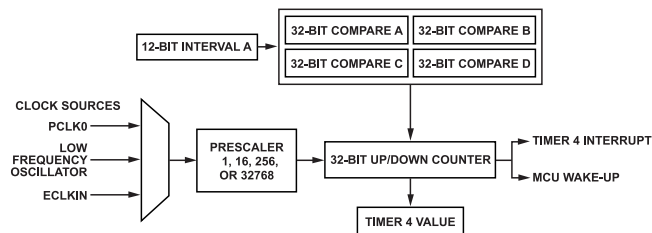

Figure 26. Wake-Up Timer Block Diagram

WAKE-UP TIMER OVERVIEW

The wake-up timer (Timer 4) block consists of a 32-bit counter clocked from one of three different sources: the system clock (PCLK0), the internal low frequency oscillator, or an external clock applied on the P2.1/DM/IRQ2/ECLKIN/COMPDI3/PLAI9 pin. The selected clock source can be scaled down using a prescaler of 1, 16, 256, or 32768. The wake-up timer continues to run independent of the clock source used when the PCLK0 clock is disabled.

The timer can be used in free running or periodic mode. In free running mode, the timer counts from 0x00000000 to 0xFFFFFFFF and then restarts at 0x00000000. In periodic mode, the timer counts from 0x00000000 to T4WUFDx (x = 0 or 1).

In addition, the wake-up timer has four specific time fields to compare with the wake-up counter: T4WUFAX, T4WUFBx, T4WUFCx, and T4WUFDx. All four wake-up compare points can generate interrupts or wake-up signals. When the timer is in free running mode, T4WUFAX, T4WUFBx, T4WUFCx, and T4WUFDx must be reconfigured in the software to generate a periodic interrupt.

WAKE-UP TIMER OPERATION

The wake-up timer comparator registers must be configured before starting the timer. The timer is started by writing to the control enable bit (T4CON, Bit 7). The timer increments until the value reaches full scale in free running mode or when T4WUFDx matches the wake-up value (T4VALx).

The wake-up timer is a 32-bit timer. Its current value is stored in two 16-bit registers: T4VAL1x stores the upper 16 bits, and T4VAL0x stores the lower 16 bits.

When T4VAL0x is read, T4VAL1x is frozen at its current value until it is subsequently read. The freeze control bit (T4CON, Bit 3) must be set to freeze the T4VALx value between the lower and upper reads.

Clock Selection

Clock selection is made by setting T4CON, Bits[10:9].

If PCLK0 is selected (T4CON, Bits[10:9] = 00), configuring T4CON, Bits[1:0] = 00 results in a prescaler of 4.

The hardware synchronizes to the low frequency oscillator clock domain automatically, and precautions concerning asynchronous clocks do not apply.

WAKE-UP TIMER**Compare Field Registers****Hardware Updated Field**

T4INC is a 12-bit interval register that updates the compare value in T4WUF_{Ax} by using hardware. When a new value is written in T4INC, Bits[16:5] of the internal 32-bit compare register (T4WUF_{Ax}) are loaded with the new T4INC value. If the new compare value is less than the T4WUFD_x value in periodic mode or less than 0xFFFFFFFF in free running mode, this 32-bit compare register is automatically incremented with the contents of T4INC (shifted by five) each time the wake-up counter reaches the value in this compare register. If the new compare value is greater than these limits, it is recalculated as follows.

In free running mode, the new value is

$$T4WUF_{Ax} = Old\ T4WUF_{xA} + (32 \times T4INC) - 0xFFFFFFFF \quad (29)$$

In periodic mode, the new value is

$$T4WUF_{Ax} = Old\ T4WUF_{Ax} + (32 \times T4INC) - T4WUFD_x \quad (30)$$

T4INC is compared with Bits[16:5] of the timer value. Because the timer value is shifted left by five bits, its value must be multiplied by 32 to obtain the compare value.

With the default value of 0xC8 (where, for calculation purposes, 0xC8 = 200 in decimal), a prescaler = 1, and a 32 kHz clock selected,

$$Interval = ((200 \times 32) + 1) \times 1/32,768 = 195.3155\ ms \quad (31)$$

To modify the interval value, the timer must be stopped so that the interval register can be loaded in the compare register if T4CON, Bit 11 = 0.

To modify the interval value, set STOPINC (T4CON, Bit 11 = 1) while the timer is running.

The new T4INC value takes effect after the next Wake-Up Field A interrupt. If the user is writing to this register while the timer is enabled, the STOPINC bit must be set before writing to it, and then STOPINC must be cleared after the update.

Software Updated Field

T4WUFB_x, T4WUFC_x, and T4WUFD_x (each consisting of a low and high bit field) are 32-bit values programmed by the user in the T4WUF_{x0} and T4WUF_{x1} registers (x = B, C, or D). T4WUFD_x contains the load value when the wake-up timer is configured in periodic mode.

The T4WUFB_x and T4WUFC_x registers can be written to at any time. However, the corresponding interrupt enable (T4IEN, Bit 1 or T4IEN, Bit 2) must be disabled. After the register is updated, the interrupt can be reenabled.

In periodic mode, the T4WUFD_x registers can be written to only when the timer is disabled. In free running mode, the T4WUFD_x registers can be written to while the timer is running. Before doing so, the corresponding interrupt enable (T4IEN, Bit 3) must be disabled. After the register is updated, the interrupt can be reenabled.

In free running mode, T4WUFB_x, T4WUFC_x, and T4WUFD_x can be written to at any time, but the corresponding interrupt enable in the T4IEN register must be disabled. After the register is updated, the interrupt can be reenabled. In periodic mode, this interrupt requirement is only applicable to T4WUFB_x and T4WUFC_x.

WAKE-UP TIMER

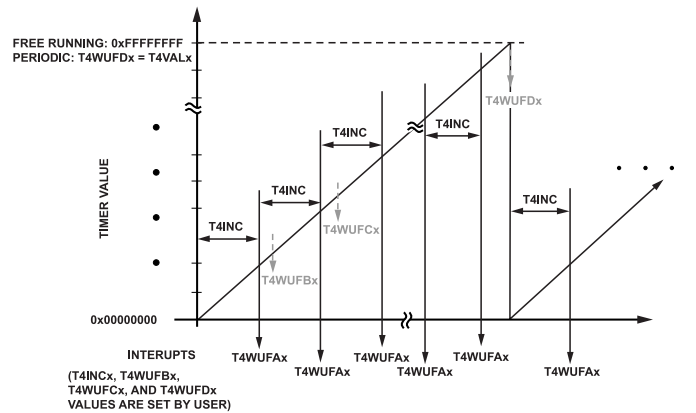

Figure 27. Wake-Up Timer Fields Action

Interrupts/Wake-Up Signals

An interrupt is generated when the counter value corresponds to any of the compare points or full scale in free running mode. The timer continues counting or is reset to 0.

The wake-up timer generates five maskable interrupts. They are enabled in the T4IEN register. Interrupts can be cleared by setting the corresponding bit in the T4CLR1 register.

Note that it takes two 32 kHz clock cycles for the interrupt clear to take effect when the 32 kHz internal oscillator is used.

Ensure that the register write has fully completed before returning from the interrupt handler. Use the DSB instruction if necessary. The following is a code example showing how to implement the DSB Arm Cortex-M33 instruction in a C program:

```
void Ext_Int4_Handler ()
{
  EiClr(EXTINT4);
  DSB();
}
```

During that time, do not place the device in any of the power-down modes. IRQCRY (T4STA, Bit 6) indicates when the device can be placed in power-down mode.

REGISTER SUMMARY: WUT

Table 239. WUT Register Summary

Address	Name	Description	Reset	Access
0x40003000	T4VAL0	Current Count Value—Least Significant 16 Bits.	0x0000	R
0x40003004	T4VAL1	Current Count Value—Most Significant 16 Bits.	0x0000	R
0x40003008	T4CON	Control.	0x0040	R/W
0x4000300C	T4INC	12-Bit Interval for Wake-Up Field A.	0x00C8	R/W
0x40003010	T4WUFB0	Wake-Up Field B—Least Significant 16 Bits.	0x1FFF	R/W
0x40003014	T4WUFB1	Wake-Up Field B—Most Significant 16 Bits.	0x0000	R/W
0x40003018	T4WUFC0	Wake-Up Field C—Least Significant 16 Bits.	0x2FFF	R/W
0x4000301C	T4WUFC1	Wake-Up Field C—Most Significant 16 Bits.	0x0000	R/W
0x40003020	T4WUFD0	Wake-Up Field D—Least Significant 16 Bits.	0x3FFF	R/W
0x40003024	T4WUFD1	Wake-Up Field D—Most Significant 16 Bits.	0x0000	R/W
0x40003028	T4IEN	Interrupt Enable.	0x0000	R/W
0x4000302C	T4STA	Status.	0x0000	R
0x40003030	T4CLR1	Clear Interrupt.	0x0000	R/W
0x4000303C	T4WUFA0	Wake-Up Field A—Least Significant 16 Bits.	0x1900	R/W

WAKE-UP TIMER

Table 239. WUT Register Summary (Continued)

Address	Name	Description	Reset	Access
0x40003040	T4WUFA1	Wake-Up Field A—Most Significant 16 Bits.	0x0000	R/W

REGISTER DETAILS: WUT

Current Count Value—Least Significant 16 Bits Register

Address: 0x40003000, Reset: 0x0000, Name: T4VAL0

Table 240. Bit Descriptions for T4VAL0

Bits	Bit Name	Settings	Description	Reset	Access
[15:0]	T4VALL		Current Count Low. Least significant 16 bits of current count value.	0x0	R

Current Count Value—Most Significant 16 Bits Register

Address: 0x40003004, Reset: 0x0000, Name: T4VAL1

Table 241. Bit Descriptions for T4VAL1

Bits	Bit Name	Settings	Description	Reset	Access
[15:0]	T4VALH		Current Count High. Most significant 16 bits of current count value.	0x0	R

Control Register

Address: 0x40003008, Reset: 0x0040, Name: T4CON

Table 242. Bit Descriptions for T4CON

Bits	Bit Name	Settings	Description	Reset	Access
[15:12]	RESERVED		Reserved.	0x0	R
11	STOPINC		Disables Updating Field A Register T4WUFAX. This bit, when set, stops the Wake-Up Field A register. T4WUFAX is updated with the interval register I2INC value. This allows the user to update the interval T4INC or T4WUFAX registers safely.	0x0	R/W
[10:9]	CLK		Clock Select. 00 PCLK0 is Peripheral Clock 0 (Default). 01 32 kHz Internal Low Frequency Oscillator. 10 32 kHz Internal Low Frequency Oscillator. 11 ECLKIN: External Clock from P2.1/DM/IRQ2/ECLKIN/COMPIN3/PLAI9.	0x0	R/W
8	WUEN		Wakeup Enable. 0 Cleared by User to Disable the Wake up Timer When the Core Clock (HCLK) is off. 1 Set by User to Enable the Wake-Up Timer Even When the Core Clock (HCLK) is Off.	0x0	R/W
7	ENABLE		Timer Enable. 0 Disable the Timer (Default). 1 Enable the Timer.	0x0	R/W
6	TMODE		Timer Mode. 0 Periodic. Cleared by User to Operate in Periodic Mode. In this mode, the timer counts up to T4WUFDx. 1 Free Run. Set by User to Operate in Free Running Mode (default).	0x1	R/W
[5:4]	RESERVED		Reserved.	0x0	R
3	FREEZE		Freeze Enable. 0 Cleared by User to Disable This Feature (default). 1 Set by User to Enable the Freeze of the High 16-bits After the Lower Bits Have Been Read from T4VAL0. This ensures that the software reads an atomic shot of the timer. T4VAL1 unfreezes after it has been read.	0x0	R/W
2	RESERVED		Reserved.	0x0	R
[1:0]	PRE		Prescaler.	0x0	R/W

WAKE-UP TIMER

Table 242. Bit Descriptions for T4CON (Continued)

Bits	Bit Name	Settings	Description	Reset	Access
		00	Source Clock/1 (default). If the selected clock source is PCLK0, then this setting results in a prescaler of 4.		
		01	Source Clock/16.		
		10	Source Clock/256.		
		11	Source Clock/32,768.		

12-Bit Interval for Wake-Up Field A Register

Address: 0x4000300C, Reset: 0x00C8, Name: T4INC

Table 243. Bit Descriptions for T4INC

Bits	Bit Name	Settings	Description	Reset	Access
[15:12]	RESERVED		Reserved.	0x0	R
[11:0]	INTERVAL		Interval for Wake-Up Field A.	0xC8	R/W

Wake-Up Field B—Least Significant 16 Bits Register

Address: 0x40003010, Reset: 0x1FFF, Name: T4WUFB0

Table 244. Bit Descriptions for T4WUFB0

Bits	Bit Name	Settings	Description	Reset	Access
[15:0]	T4WUFBL		Wake-Up Field B Low. Least significant 16 bits of Wake-Up Field B.	0x1FFF	R/W

Wake-Up Field B—Most Significant 16 Bits Register

Address: 0x40003014, Reset: 0x0000, Name: T4WUFB1

Table 245. Bit Descriptions for T4WUFB1

Bits	Bit Name	Settings	Description	Reset	Access
[15:0]	T4WUFBH		Wake-Up Field B High. Most significant 16 bits of Wake-Up Field B.	0x0	R/W

Wake-Up Field C—Least Significant 16 Bits Register

Address: 0x40003018, Reset: 0x2FFF, Name: T4WUFC0

Table 246. Bit Descriptions for T4WUFC0

Bits	Bit Name	Settings	Description	Reset	Access
[15:0]	T4WUFCCL		Wake-Up Field C Low. Least significant 16 bits of Wake-Up Field C.	0x2FFF	R/W

Wake-Up Field C—Most Significant 16 Bits Register

Address: 0x4000301C, Reset: 0x0000, Name: T4WUFC1

Table 247. Bit Descriptions for T4WUFC1

Bits	Bit Name	Settings	Description	Reset	Access
[15:0]	T4WUFCCH		Wake-Up Field C High. Most significant 16 bits of Wake-Up Field C.	0x0	R/W

Wake-Up Field D—Least Significant 16 Bits Register

Address: 0x40003020, Reset: 0x3FFF, Name: T4WUFD0

Table 248. Bit Descriptions for T4WUFD0

Bits	Bit Name	Settings	Description	Reset	Access
[15:0]	T4WUFD0		Wake-Up Field D Low. Least significant 16 bits of Wake-Up Field D.	0x3FFF	R/W

WAKE-UP TIMER

Wake-Up Field D—Most Significant 16 Bits Register

Address: 0x40003024, Reset: 0x0000, Name: T4WUFD1

Table 249. Bit Descriptions for T4WUFD1

Bits	Bit Name	Settings	Description	Reset	Access
[15:0]	T4WUFDH		Wake-Up Field D High. Most significant 16 bits of Wake-Up Field D.	0x0	R/W

Interrupt Enable Register

Address: 0x40003028, Reset: 0x0000, Name: T4IEN

Table 250. Bit Descriptions for T4IEN

Bits	Bit Name	Settings	Description	Reset	Access
[15:5]	RESERVED		Reserved.	0x0	R
4	ROLL		Rollover Interrupt Enable. Used only in free running mode. Set by user to generate an interrupt when the timer rolls over. Cleared by user to disable the rollover interrupt (default).	0x0	R/W
3	WUFD		T4WUFDx Interrupt Enable. Set by user code to generate an interrupt when T4VALx reaches T4WUFDx. Cleared by user code to disable T4WUFDx interrupt (default).	0x0	R/W
2	WUFC		T4WUFCx Interrupt Enable. Set by user code to generate an interrupt when T4VALx reaches T4WUFCx. Cleared by user code to disable T4WUFCx interrupt (default).	0x0	R/W
1	WUFB		T4WUFBx Interrupt Enable. Set by user code to generate an interrupt when T4VALx reaches T4WUFBx. Cleared by user code to disable T4WUFBx interrupt (default).	0x0	R/W
0	WUFA		T4WUFAX Interrupt Enable. Set by user code to generate an interrupt when T4VALx reaches T4WUFAX. Cleared by user code to disable T4WUFAX interrupt (default).	0x0	R/W

Status Register

Address: 0x4000302C, Reset: 0x0000, Name: T4STA

Table 251. Bit Descriptions for T4STA

Bits	Bit Name	Settings	Description	Reset	Access
[15:9]	RESERVED		Reserved.	0x0	R
8	PDOK		Enable Bit Synchronization. Indicates when a change in the enable bit is synchronized to the 32 kHz clock domain. It is set high when the enable bit (Bit 7) in the control register is set or cleared. It returns low when the change in the enable bit has been synchronized to the 32 kHz clock domain.	0x0	R
7	FREEZE		Timer Value Freeze. Set automatically to indicate that the value in T4VAL1 is frozen. Cleared by automatically when T4VAL1 is read.	0x0	R
6	IRQCRY		Wake-Up Status to Power Down. Set automatically when any of the interrupts are still set in the external crystal clock domain. Cleared automatically when the interrupts are cleared, allowing power-down mode. User code must wait for this bit to be cleared before entering power-down mode.	0x0	R
5	RESERVED		Reserved.	0x0	R
4	ROLL		Rollover Interrupt Flag. Used only in free running mode. Set automatically to indicate a rollover interrupt has occurred. Cleared automatically after a write to T4CLR1.	0x0	R
3	WUFD		T4WUFDx Interrupt Flag. Set automatically to indicate a comparator interrupt has occurred. Cleared automatically after a write to the corresponding bit in T4CLR1.	0x0	R
2	WUFC		T4WUFCx Interrupt Flag. Set automatically to indicate a comparator interrupt has occurred. Cleared automatically after a write to the corresponding bit in T4CLR1.	0x0	R
1	WUFB		T4WUFBx Interrupt Flag. Set automatically to indicate a comparator interrupt has occurred. Cleared automatically after a write to the corresponding bit in T4CLR1.	0x0	R
0	WUFA		T4WUFAX Interrupt Flag. Set automatically to indicate a comparator interrupt has occurred. Cleared automatically after a write to the corresponding bit in T4CLR1.	0x0	R

WAKE-UP TIMER**Clear Interrupt Register**

Address: 0x40003030, Reset: 0x0000, Name: T4CLRI

Table 252. Bit Descriptions for T4CLRI

Bits	Bit Name	Settings	Description	Reset	Access
[15:5]	RESERVED		Reserved.	0x0	R
4	ROLL		Rollover Interrupt Clear. Used only in free running mode. Set by user code to clear a roll over interrupt flag. Cleared automatically after synchronization.	0x0	R/W
3	WUFD		T4WUFDx Interrupt Clear.	0x0	R/W
2	WUFC		T4WUFCx Interrupt Clear. Set by user code to clear a T4WUFCx interrupt flag. Cleared automatically after synchronization.	0x0	R/W
1	WUFB		T4WUFBx Interrupt Clear. Set by user code to clear a T4WUFBx interrupt flag. Cleared automatically after synchronization.	0x0	R/W
0	WUFA		T4WUFAX Interrupt Clear. Set by user code to clear a T4WUFAX interrupt flag. Cleared automatically after synchronization.	0x0	R/W

Wakeup Field A—Least Significant 16 Bits Register

Address: 0x4000303C, Reset: 0x1900, Name: T4WUFA0

Table 253. Bit Descriptions for T4WUFA0

Bits	Bit Name	Settings	Description	Reset	Access
[15:0]	T4WUFAL		Wake-Up Field A Low. Least significant 16 bits of Wake-Up Field A.	0x1900	R/W

Wakeup Field A—Most Significant 16 Bits Register

Address: 0x40003040, Reset: 0x0000, Name: T4WUFA1

Table 254. Bit Descriptions for T4WUFA1

Bits	Bit Name	Settings	Description	Reset	Access
[15:0]	T4WUFAH		Wake-Up Field A High. Most significant 16 bits of Wake-Up Field A.	0x0	R/W

WATCHDOG TIMER

WATCH DOG TIMER FEATURES

Watchdog timer (WDT) is used to recover from an illegal software state. After the WDT is enabled by user code, it requires periodic servicing to prevent it from forcing a reset of the processor.

WATCHDOG TIMER BLOCK DIAGRAM

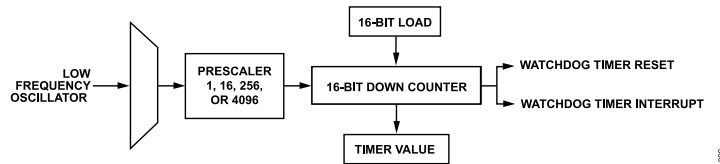

Figure 28. Watchdog Timer Block Diagram

The watchdog timer is clocked by the 32 kHz on-chip low frequency oscillator (see the [Clocking Architecture](#) section). The watchdog timer is always clocked while in debug mode, except during reset, and when it is selectively disabled while in hibernate mode.

The watchdog timer is a 16-bit countdown timer with a programmable prescaler. The prescaler source is selectable and can be scaled by a factor of 1, 16, 256, or 4096.

The watchdog timer is a windowed timer, meaning it has an upper and lower refresh period. The watchdog timer triggers a reset if the following occurs:

- ▶ The timer is not refreshed before the largest interval. The largest interval is set by the user via the LD register.
- ▶ The timer is refreshed before the shortest interval. The shortest interval is set by the user via the MINLD register.
- ▶ The timer is refreshed by writing 0xCCCC to CLRI. Ensure STA, Bit 1 = 0 before writing to the CLRI register to ensure the previous refresh cycle is complete.
- ▶ A watchdog timer reset is forced by writing a value other than 0xCCCC to the CLRI register.

WATCH DOG TIMER OPERATION

After any reset, the watchdog timer is initialized with an initial configuration. This initial configuration can be modified by user code. However, setting the EN bit in the WDT CON register write protects the WDT CON register. This means the watchdog timer keeps running. Only a reset clears the write protection and allows reconfiguring of the timer. When the watchdog timer is not enabled, it can be reconfigured at any time.

When the watchdog timer decrements to 0, a reset is generated. This reset can be prevented by writing 0xCCCC to the CLRI register. Writing 0xCCCC to CLRI causes the watchdog timer to reload with the WDT configuration (in free running mode). The watchdog timer immediately begins a new timeout period and starts to count again.

The reset output of the watchdog timer works solely from the 32 kHz clock and does not require the system clock to be active. Therefore, the watchdog timer can work with all the power-down modes, including hibernate mode.

In MCU software debugging mode, disable the WDT first before software debugging.

In summary, the key features include the following:

- ▶ Watchdog timer is on by default with a timeout period of 16 sec.
- ▶ Clock for the watchdog timer is a 32 kHz oscillator.
- ▶ The watchdog timer control register is a write once register. Therefore, after initialization, it is not possible to disable it without a full reset of the chip.
- ▶ The exact value of 0xCCCC must be written to the CLRI register. Any other value causes a reset.

The following is an example function to refresh the watchdog timer:

```

uint32_t WdtRefresh(void)
{
    //BITM_WDT_STA_CLRI set means previous Watchdog Timer refresh is still in progress, do not try an▶
    other refresh
  
```

WATCHDOG TIMER

```

if(!(pADI_WDT->STA & BITM_WDT_STA_CLRI)) // Check STA[1] is clear before refreshing
{
    pADI_WDT->CLRI = (uint16_t)WDT_REFRESH_VALUE; // 0xCCCC is the REFRESH_VALUE
}
return 1;
}

```

WINDOWED WATCHDOG FEATURE

The windowed watchdog feature provides extra robustness to the watchdog timer for safety critical applications. With the windowed watchdog feature enabled, the watchdog timer resets if the user code refreshes the watchdog timer either too quickly or too slowly.

When this feature is enabled in the WDT control register (CON, Bit 9) set to 1, the watchdog timer must be refreshed before the counter value reaches 0, but it must be refreshed after the counter has passed the value written to the MINLD register.

The following are example instructions to set up the windowed watchdog feature:

```

pADI_WDT->LD = 0x800; //16 second timeout period
pADI_WDT->MINLD = 0x600; // Min window is 4s after start
pADI_WDT->CON = 0x248; // Enable Windowed feature

```

INTERRUPT MODE

If a watchdog reset occurs while debugging via the SWD port, communications between the debugger and the ADuCM410 and ADuCM420 can be lost.

If debugging, the user can optionally configure the watchdog timer to generate an interrupt instead of a reset. Enable this feature only during code development and debugging. Enable the watchdog timer to generate a reset in user full applications.

If the watchdog timer interrupt source does not wake up the device from hibernate modem, then setting CON, Bit 0 = 1 or 0 has no effect in interrupt mode.

The following are example instructions to set up the watchdog timer in interrupt mode:

```

pADI_WDT->LD = 0x200; //4second timeout period
pADI_WDT->CON = 0x44A; // WDT IRQ, Window On, periodic, Clock div256,
NVIC_EnableIRQ(WDT_IRQn); // Enable the NVIC interrupt for the Watchdog timer

```

REGISTER SUMMARY: WATCHDOG TIMER REGISTER MAP (WDT)

Table 255. WDT Register Summary

Address	Name	Description	Reset	Access
0x40004000	LD	Watchdog Timer Load Value Register.	0x1000	R/W
0x40004004	VALS	Current Count Value Register.	0x1000	R
0x40004008	CON	Watchdog Timer Control Register.	0x00E9	R/W
0x4000400C	CLRI	Refresh Watchdog Register.	0x0000	W
0x40004018	STA	Timer Status Register.	0x0000	R
0x4000401C	MINLD	Minimum Load Value Register.	0x0800	R/W

WATCHDOG TIMER

REGISTER DETAILS: WATCHDOG TIMER REGISTER MAP (WDT)

Watchdog Timer Load Value Register

Address: 0x40004000, Reset: 0x1000, Name: LD

Table 256. Bit Descriptions for LD

Bits	Bit Name	Settings	Description	Reset	Access
[15:0]	LOAD		WDT Load Value. User programmable value. This is the value that the counter starts from and counts down to 0.	0x1000	R/W

Current Count Value Register

Address: 0x40004004, Reset: 0x1000, Name: VALS

Table 257. Bit Descriptions for VALS

Bits	Bit Name	Settings	Description	Reset	Access
[15:0]	CCOUNT		Current WDT Count Value. Read only register. Returns the counters value when read.	0x1000	R

Watchdog Timer Control Register

Address: 0x40004008, Reset: 0x0069, Name: CON

Table 258. Bit Descriptions for CON

Bits	Bit Name	Settings	Description	Reset	Access
[15:11]	RESERVED		Reserved.	0x0	R
10	WDTIRQEN		WDT Interrupt Enable. Set to 1 to enable an interrupt to the interrupt controller. Clear to 0 to disable the interrupt source.	0x0	R/W
9	MINLOADEN		Timer Window Control. When enabled, if user refreshes the timer before the counter reaches value in MINLOAD, a reset or IRQ occurs.	0x0	R/W
8	CLKDIV2		Clock Source.	0x0	R/W
7	RESERVED		Reserved.	0x0	R
6	MDE		Timer Mode Select. 0 Free Running Mode. Note that in free running mode, the timer wraps around at 0x1000. 1 Periodic Mode (Default). In this mode, the counter counts from the WDT LD value down to 0.	0x1	R/W
5	EN		Timer Enable.	0x1	R/W
4	RESERVED		Reserved.	0x1	R
[3:2]	PRE		Prescaler for the Input Clock of the Timer. 00 Source Clock/1. 01 Source Clock/16. 10 Source Clock/256 (Default). 11 Source Clock/4096.	0x2	R/W
1	IRQ		WDT Interrupt Enable. 0 Watchdog Timer Timeout Creates a Reset. 1 Watchdog Timer Timeout Creates an Interrupt Instead of Reset.	0x0	R/W
0	PDSTOP		Power Down Stop Enable. 0 Continue Counting When in Hibernate. The watchdog timer continues its countdown while in hibernate mode. 1 Stop Counter When in Hibernate. When hibernate mode is entered, the watchdog counter suspends its countdown. As hibernate mode is exited, the countdown resumes from its current count value (the count is not reset).	0x1	R/W

WATCHDOG TIMER**Refresh Watchdog Register**

Address: 0x4000400C, Reset: 0x0000, Name: CLRI

Clear watchdog.

Table 259. Bit Descriptions for CLRI

Bits	Bit Name	Settings	Description	Reset	Access
[15:0]	CLRWDG		Refresh Register. User writes 0xCCCC to reset, reload, or restart the counter or clear IRQ. A write of any other value causes a watchdog reset or IRQ. Write only, reads 0.	0x0	W

Timer Status Register

Address: 0x40004018, Reset: 0x0000, Name: STA

Timer status.

Table 260. Bit Descriptions for STA

Bits	Bit Name	Settings	Description	Reset	Access
[15:7]	RESERVED		Reserved.	0x0	R
6	TMINLD		WDT MINLOAD Write Status.	0x0	R
5	RESERVED		Reserved.	0x0	R
4	LOCKS		Lock Status. 0 Timer Operation Not Locked. 1 Timer Enabled and Locked. Set automatically in hardware when WDTCON, Bit 5 has been set by user code.	0x0	R
3	CON		WDTCON Write Status.	0x0	R
2	TLD		WDTVAL Write Status.	0x0	R
1	CLRI		WDTCLRI Write Status.	0x0	R
0	IRQ		WDT Interrupt. Set to 1 when the watchdog timer interrupt occurs. 0 Watchdog Timer Interrupt Not Pending. 1 Watchdog Timer Interrupt Pending. Cleared by writing to WDT CLRI register.	0x0	R

Minimum Load Value Register

Address: 0x4000401C, Reset: 0x0800, Name: MINLD

Watchdog timer minimum timeout period. Lower window limit.

Table 261. Bit Descriptions for MINLD

Bits	Bit Name	Settings	Description	Reset	Access
[15:0]	MINLOAD		WDT Minimum Load Value. If the software writes to WDT CLRI before the counter reaches the MINLOAD value, a WDT reset or IRQ occurs.	0x800	R/W

DIRECT MEMORY ACCESS (DMA) CONTROLLER

DMA FEATURES

The ADuCM410 and ADuCM420 provide 31 dedicated and independent DMA channels.

Each DMA channel has two programmable priority levels. Each priority level arbitrates using a fixed priority that is determined by the DMA channel number. Channels with lower numbers have higher priority. For example, the SPI0 transmit has the highest priority, and the next highest is the SPI0 receive.

Each DMA channel can access a primary and/or alternate channel control structure.

Normally, DMA requests are triggered by a dedicated peripheral for peripheral related channels. However, there are two channels, TRIG0 and TRIG1, that can be triggered by the PLA. For example, if the PLA outputs a clock based on a timer, the DMA can transfer data from SRAM to a DACDATx register, which allows user waveforms to be generated on a DAC output.

Multiple DMA transfer types are supported, including memory to memory, memory to peripheral, and peripheral to memory.

DMA OVERVIEW

DMA provides high speed or timer-based data transfers between peripherals and memory. Data can be moved quickly by DMA without any processor actions, which keeps processor resources free for other operations.

The DMA controller has 31 channels in total. The 31 channels are dedicated to managing DMA requests from specific peripherals. Channels are assigned as shown in [Table 262](#).

Table 262. DMA Channel Assignment

Channel	Peripheral
0	SPI0 Tx
1	SPI0 Rx
2	SPI1 Tx
3	SPI1 Rx
4	SPI2 Tx
5	SPI2 Rx
6	UART0 Tx
7	UART0 Rx
8	UART1 Tx
9	UART1 Rx
10	I ² C0 slave Tx
11	I ² C0 slave Rx
12	I ² C0 master
13	I ² C1 slave Tx
14	I ² C1 slave Rx
15	I ² C1 master
16	I ² C2 slave Tx
17	I ² C2 slave Rx
18	I ² C2 master
19	Reserved
20	Reserved
21	Flash
22	ADC
23	Reserved
24	Reserved
25	Reserved
26	Reserved
27	TRIG0
28	TRIG1
29	Software 0

DIRECT MEMORY ACCESS (DMA) CONTROLLER

Table 262. DMA Channel Assignment (Continued)

Channel	Peripheral
30	Software 1

The channels are connected to dedicated hardware DMA requests. A software trigger is also supported on each channel. The trigger is configured by the software.

The DMA controller supports multiple DMA transfer data widths: independent source and destination transfer size (byte, half word, and word). Source and destination addresses must be aligned on the data size.

The DMA controller supports peripheral to memory, memory to peripheral, and memory to memory transfers and access to flash or SRAM as the source and destination.

DMA OPERATION

The DMA controller performs direct memory transfer by sharing the system bus with the Cortex-M33 processor. The DMA request may stall the processor access to the system bus for some bus cycles when the processor and DMA are targeting the same destination (memory or peripheral).

DMA INTERRUPTS

An interrupt can be produced for each DMA channel when a transfer is complete. Separate interrupt enable bits are available in the NVIC for each DMA channel.

The DMA controller fetches channel control data structures located in the SRAM memory to perform data transfers. When enabled to use DMA operation, the DMA capable peripherals request the DMA controller for a transfer. At the end of the programmed number of DMA transfers for a channel, the DMA controller generates an interrupt corresponding to that channel. This interrupt indicates the completion of the DMA transfer.

DMA PRIORITY

The number and priority level determine the priority of a channel. Each channel can have two priority levels: default or high. All channels at a high priority level have higher priority than all channels at the default priority level. At the same priority level, a channel with a lower channel number has higher priority than a channel with a higher channel number. The DMA channel priority levels can be changed by writing into the appropriate bit in the PRISET register (see the [DMA Channel Priority Set Register](#) section for details).

CHANNEL CONTROL DATA STRUCTURE

Every channel has two control data structures associated with it: primary and alternate. For simple transfer modes, the DMA controller uses either the primary or the alternate data structure. For more complex data transfer modes, such as ping pong or scatter gather, the DMA controller uses both the primary and alternate data structures. Each control data structure (primary or alternate) occupies four 32-bit locations in the memory, as shown in [Table 263](#). The entire channel control data structure is shown in [Table 264](#).

Table 263. Channel Control Data Structure

Offset	Name	Description
0x00	SRC_END_PTR	Source end pointer
0x04	DST_END_PTR	Destination end pointer
0x08	CHNL_CFG	Control data configuration
0x0C	Reserved	Reserved

Before the controller can perform a DMA transfer, the data structure related to the DMA channel must be programmed at the designated location in system memory, SRAM.

- ▶ The source end pointer memory location contains the end address of the source data.
- ▶ The destination end pointer memory location contains the end address of the destination data.
- ▶ The control data configuration memory location contains the channel configuration control data.

The programming determines the source and destination data size, number of transfers, and the number of arbitrations.

DIRECT MEMORY ACCESS (DMA) CONTROLLER

Table 264. Memory Map of Primary and Alternate DMA Structures

Channel	Primary Structures		Alternate Structures	
	Register Description	Offset Address	Register Description	Offset Address
Channel 30	Reserved; set to 0	0x1EC	Reserved; set to 0	0x2EC
	Control	0x1E8	Control	0x2E8
	Destination end pointer	0x1E4	Destination end pointer	0x2E4
	Source end pointer	0x1E0	Source end pointer	0x2E0
...
Channel 1	Reserved; set to 0	0x01C	Reserved; set to 0	0x21C
	Control	0x018	Control	0x218
	Destination end pointer	0x014	Destination end pointer	0x214
	Source end pointer	0x010	Source end pointer	0x210
Channel 0	Reserved; set to 0	0x00C	Reserved; set to 0	0x20C
	Control	0x008	Control	0x208
	Destination end pointer	0x004	Destination end pointer	0x204
	Source end pointer	0x000	Source end pointer	0x200

The user must define DMA structures in their source code, as shown in the examples in the [Example Code: Define DMA Structures](#) section. After the structure has been defined, its start address must be assigned to the DMA base address pointer register, PDBPTR.

Each register for each DMA channel is then at the offset address, as specified in [Table 264](#), plus the value in the PDBPTR register.

Example Code: Define DMA Structures

To define DMA structures, use the following code:

```
memset(dmaChanDesc,0x0,sizeof(dmaChanDesc)); // Set up the DMA base address pointer register.
uiBasPtr = (unsigned int)&dmaChanDesc; // Set up the DMA base pointer.
pADI_DMA->CFG = 1; // Enable DMA controller
pADI_DMA->PDBPTR = uiBasPtr;
```

CONTROL DATA CONFIGURATION

For each DMA transfer, the CHNL_CFG memory location provides the control information for the DMA transfer to the controller.

Table 265. Control Data Configuration

Bit(s)	Name	Description		
[31:30]	DST_INC	Destination address increment. The address increment depends on the source data width as follows:		
		Source Data Width	DST_INC	Destination Address Increment
		Byte	00	Byte.
			01	Half word.
			10	Word.
			11	No increment. Address remains set to the value that the DST_END_PTR memory location contains.
		Half Word	00	Reserved.
			01	Half word.
			10	Word.
			11	No increment. Address remains set to the value that the DST_END_PTR memory location contains.
		Word	00	Reserved.
			01	Reserved.
10	Word.			

DIRECT MEMORY ACCESS (DMA) CONTROLLER

Table 265. Control Data Configuration (Continued)

Bit(s)	Name	Description
		11 No increment. Address remains set to the value that the DST_END_PTR memory location contains.
[29:28]	DST_SIZE	Size of the destination data. Must match SRC_SIZE. 00: byte. 01: half word. 10: word. 11: reserved.
[27:26]	SRC_INC	Source address increment. The address increment depends on the source data width as follows:
	Source Data Width	SRC_INC Source Address Increment
	Byte	00 Byte. 01 Half word. 10 Word. 11 No increment. Address remains set to the value that the SRC_END_PTR memory location contains.
	Half Word	00 Reserved. 01 Half word. 10 Word. 11 No increment. Address remains set to the value that the SRC_END_PTR memory location contains.
	Word	00 Reserved. 01 Reserved. 10 Word. 11 No increment. Address remains set to the value that the SRC_END_PTR memory location contains.
[25:24]	SRC_SIZE	Size of the source data. 00: byte. 01: half word. 10: word. 11: reserved.
[23:18]	Reserved	Undefined. Write as 0.
[17:14]	R_POWER	Set these bits to control how many DMA transfers can occur before the controller rearbiterates. Must be set to 0000 for all DMA transfers involving peripherals. Note that the operation of the DMA is indeterminate if a value other than 0000 is programmed in this location for DMA transfers involving peripherals.
[13:4]	N_MINUS_1	The number of configured transfers minus 1 for that channel. The 10-bit value indicates the number of DMA transfers (not the total number of bytes) minus one. The possible values are 0x000: 1 DMA transfer. 0x001: 2 DMA transfers. 0x002: 3 DMA transfers. ... 0x3FF: 1024 DMA transfers.
3	Reserved	Undefined. Write as 0.
[2:0]	CYCLE_CTRL	The transfer types of the DMA cycle. 000: stop (invalid). 001: basic. 010: autorequest. 011: ping pong. 100: memory scatter gather primary. 101: memory scatter gather alternate. 110: peripheral scatter gather primary.

DIRECT MEMORY ACCESS (DMA) CONTROLLER

Table 265. Control Data Configuration (Continued)

Bit(s)	Name	Description
		111: peripheral scatter gather alternate.

During the DMA transfer process, but before arbitration, CHNL_CFG is written back to system memory with the N_MINUS_1 field changed to reflect the number of transfers yet to be completed.

When the DMA cycle is complete, the CYCLE_CTRL bits are made invalid to indicate the completion of the transfer.

DMA TRANSFER TYPES (CHNL_CFG, BITS[2:0])

The DMA controller supports five types of DMA transfers. The various types are selected by programming the appropriate values into the CYCLE_CTRL bits (Bits[2:0]) in the CHNL_CFG location of the control data structure.

Invalid (CHNL_CFG, Bits[2:0] = 000)

CHNL_CFG[2:0] = 000 means no DMA transfer is enabled for the channel. After the controller completes a DMA cycle, it sets the cycle type to invalid to prevent it from repeating the same DMA cycle.

Basic (CHNL_CFG, Bits[2:0] = 001)

In basic mode, the controller can be configured to use either the primary or alternate data structure. The peripheral must present a request for every data transfer. After the channel is enabled, when the controller receives a request, it performs the following steps:

1. The controller performs a transfer. If the number of transfers remaining is zero, the flow continues at Step 3.
2. The controller arbitrates. If a higher priority channel is requesting service, the controller services that channel. If the peripheral or software signals a request to the controller, the controller restarts at Step 1.
3. At the end of the transfer, the controller generates the corresponding DMA channel interrupt in the NVIC.

Autorequest (CHNL_CFG, Bits[2:0] = 010)

When the controller operates in autorequest mode, it is only necessary for the controller to receive a single request to enable it to complete the entire DMA cycle. This mode allows a large data transfer to occur without significantly increasing the latency for servicing higher priority requests or requiring multiple requests from the processor or peripheral. This mode is very useful for a memory to memory copy application.

Autorequest is not suitable for peripheral use, except for the ADC sequencer mode, where several peripheral operations must be completed.

In this mode, the controller can be configured to use either the primary or alternate data structure. After the channel is enabled, when the controller receives a request, it performs the following operations:

1. The controller performs $\min(2^{R_POWER}, N)$ transfers for the channel, where R_POWER is Bits[17:14] of the control data configuration register, and N is the number of transfers. If the number of transfers remaining is zero, the flow continues at Step 3.
2. A request for the channel is automatically generated. The controller arbitrates. If the channel has the highest priority, the DMA cycle restarts at Step 1.
3. At the end of the transfer, the controller generates an interrupt for the corresponding DMA channel.

Ping Pong (CHNL_CFG, Bits[2:0] = 011)

In ping pong mode, the controller performs a DMA cycle using one of the data structures and then performs a DMA cycle using the other data structure. The controller continues to alternate between using the primary and alternate data structures until it reads a data structure that is invalid, or the host processor disables the channel.

This mode is useful for transferring data from peripheral to memory using different buffers in the memory. In a typical application, the host must configure both primary and alternate data structures before starting the transfer. As the transfer progresses, the host can subsequently configure primary or alternate control data structures in the interrupt service routine when the corresponding transfer ends.

The DMA controller interrupts the processor after the completion of transfers associated with each control data structure. The individual transfers using either the primary or alternate control data structure work the same as a basic DMA transfer.

DIRECT MEMORY ACCESS (DMA) CONTROLLER**Memory Scatter Gather (CHNL_CFG, Bits[2:0] = 100 or 101)**

In memory scatter gather mode, the controller must be configured to use both the primary and alternate data structures. The controller uses the primary data structure to program the control configuration for the alternate data structure. The alternate data structure is used for actual data transfers, which are like an autorequest DMA transfer. The controller arbitrates after every primary transfer. The controller needs only one request to complete the entire transfer. This mode is used when performing multiple memory to memory copy tasks. The processor can configure all the tasks simultaneously and does not need to intervene in between each task. The controller generates the corresponding DMA channel interrupt in the NVIC when the entire scatter gather transaction completes using a basic cycle.

In this mode, the controller receives an initial request and then performs four DMA transfers using the primary data structure to program the control structure of the alternate data structure. After this transfer completes, the controller starts a DMA cycle using the alternate data structure. After the cycle completes, the controller performs another four DMA transfers using the primary data structure. The controller continues to alternate between using the primary and alternate data structures until the processor configures the alternate data structure for a basic cycle, or the DMA reads an invalid data structure.

Table 266 lists the fields of the CHNL_CFG memory location for the primary data structure, which must be programmed with constant values for the memory scatter gather mode.

Table 266. CHNL_CFG for Primary Data Structure in Memory Scatter Gather Mode, CHNL_CFG, Bits[2:0] = 100

Bit(s)	Name	Description
[31:30]	DST_INC	10: configures the controller to use word increments for the address.
[29:28]	DST_SIZE	10: configures the controller to use word transfers.
[27:26]	SRC_INC	10: configures the controller to use word increments for the address.
[25:24]	SRC_SIZE	10: configures the controller to use word transfers.
[23:18]	Reserved	Undefined. Write as 0.
[17:14]	R_POWER	0010: indicates that the DMA controller is to perform four transfers.
[13: 4]	N_MINUS_1	Configures the controller to perform N DMA transfers, where N is a multiple of 4.
3	Reserved	Undefined. Write as 0.
[2:0]	CYCLE_CTRL	100: configures the controller to perform a memory scatter gather DMA cycle.

Peripheral Scatter Gather (CHNL_CFG, Bits[2:0] = 110 or 111)

In peripheral scatter gather mode, the controller must be configured to use both the primary and alternate data structure. The controller uses the primary data structure to program the control structure of the alternate data structure. The alternate data structure is used for actual data transfers, and each transfer takes place using the alternate data structure with a basic DMA transfer. The controller does not arbitrate after every primary transfer. This mode is used when there are multiple peripheral to memory DMA tasks to be performed. The Cortex-M33 can configure all the tasks simultaneously and does not need to intervene in between each task. This mode is very similar to memory scatter gather mode except for arbitration and request requirements. The controller generates the corresponding DMA channel interrupt in the NVIC when the entire scatter gather transaction completes using a basic cycle.

In peripheral scatter gather mode, the controller receives an initial request from a peripheral and then performs four DMA transfers using the primary data structure to program the alternate control data structure. The controller then immediately starts a DMA cycle using the alternate data structure without re-arbitrating.

After this cycle completes, the controller re-arbitrates, and if it receives a request from the peripheral that has the highest priority, it performs another four DMA transfers using the primary data structure. The controller then immediately starts a DMA cycle using the alternate data structure without re-arbitrating. The controller continues to alternate between using the primary and alternate data structures until the processor configures the alternate data structure for a basic cycle, or the DMA reads an invalid data structure.

Table 267 lists the fields of the CHNL_CFG memory location for the primary data structure, which must be programmed with constant values for the peripheral scatter gather mode.

Table 267. CHNL_CFG for Primary Data Structure in Peripheral Scatter Gather Mode, CHNL_CFG, Bits[2:0] = 110

Bit(s)	Name	Description
[31:30]	DST_INC	10: configures the controller to use word increments for the address.
[29:28]	DST_SIZE	10: configures the controller to use word transfers.
[27:26]	SRC_INC	10: configures the controller to use word increments for the address.

DIRECT MEMORY ACCESS (DMA) CONTROLLER

Table 267. CHNL_CFG for Primary Data Structure in Peripheral Scatter Gather Mode, CHNL_CFG, Bits[2:0] = 110 (Continued)

Bit(s)	Name	Description
[25:24]	SRC_SIZE	10: configures the controller to use word transfers.
[23:18]	Reserved	Undefined. Write as 0.
[17:14]	R_POWER	0010: indicates that the DMA controller performed four transfers without re arbitration.
[13: 4]	N_MINUS_1	Configures the controller to perform N DMA transfers, where N is a multiple of 4.
3	Reserved	Undefined. Write as 0.
[2:0]	CYCLE_CTRL	110: configures the controller to perform a memory scatter gather DMA cycle.

ADDRESS CALCULATION

The DMA controller calculates the source read address based on the content of SRC_END_PTR, the source address increment setting in CHNL_CFG, and the current value of N_MINUS_1 (CHNL_CFG, Bits[13:4]).

Similarly, the destination write address is calculated based on the content of DST_END_PTR, the destination address increment setting in CHNL_CFG, and the current value of N_MINUS_1 (CHNL_CFG, Bits[13:4]).

For SRC_INC = 0, 1, or 2,

$$\text{Source Read Address} = \text{SRC_END_PTR} - (\text{N_MINUS_1} \ll (\text{SRC_INC})) \quad (32)$$

For SRC_INC = 3,

$$\text{Source Read Address} = \text{SRC_END_PTR} \quad (33)$$

For DST_INC = 0, 1, or 2,

$$\text{Destination Write Address} = \text{DST_END_PTR} - (\text{N_MINUS_1} \ll (\text{DST_INC})) \quad (34)$$

For DST_INC = 3,

$$\text{Destination Write Address} = \text{DST_END_PTR} \quad (35)$$

N_MINUS_1 is the number of configured transfers minus 1 for that channel.

PLA TRIGGER CHANNEL

TRIG0 and TRIG1 (DMA Channel 27 and DMA Channel 28) are PLA triggered channels.

The DMA requests are generated by PLA logic, which can be configured by the user.

These two channels have the same flexibility as the software channel, which means the source address and destination address are specified by software. For example, DACDAT0 or SPI0 TX can be the destination address. Also, the R_POWER field is not limited to 0 as other peripheral channels.

Use Case 1: VDAC Waveform Generation Via PLA Triggered DMA Channel

In this case, consider a square wave generated from PLA Element 3. The DACDAT0 data register can be updated at a rate of 20 kHz. See the [Programmable Logic Array \(PLA\)](#) section for details about how to generate such a signal from the PLA.

The REQ0SEL register allows the user to select which PLA source to trigger a DMA via the TRIG0 channel.

The PLA_REQ0, PLA_REQ1, PLA_REQ2, and PLA_REQ3 options in REQ0SEL correspond to the requests in PLA_IRQ0 and PLA_IRQ1.

The following code explains how to set these registers:

```
//DMAREQ setting, only two channels available, use channel 0 in this case
pADI_DMAREQ->REQEN |= BITM_DMAREQ_GPLA_DMA_EN0; // DMA channel 0 enabled
pADI_DMAREQ->REQ0SEL = ENUM_DMAREQ_DMA_REQ0_SEL_PLA_REQ0; // request from PLA_IRQ0
pADI_PLA->PLA_IRQ0 = 3; //source of_IRQ0 is set to PLA element 3
pADI_DMAREQ->PLAREQEN |= BITM_DMAREQ_PLA_DMA_REQ0_EN; //PLA request 0 enabled
//DMA descriptor setting
```

DIRECT MEMORY ACCESS (DMA) CONTROLLER

```
srcEndPtr = (uint32_t)((uint32_t)gWaveDat + (WAVE_DATA_BUFFER_LEN/2- 1)*4); //source data code from SRAM.
destEndPtr = (uint32_t>(&pADI_VDAC->DACDAT1); //transfer to VDAC1 channel
ctrlCfg.Bits.r_power = 0; //2^0, one word each request
ctrlCfg.Bits.n_minus_1 = WAVE_DATA_BUFFER_LEN/2-1;
```

Use Case 2: SPI Frame Transfer

The DMA can be used with an SPI master interface. The R_POWER setting determines the SPI frame length.

Refer to the [Use Case 1: VDAC Waveform Generation Via PLA Triggered DMA Channel](#) section for a DMA triggered via the PLA.

The DMA descriptor settings for SPI0 TX follows:

```
srcEndPtr = (uint32_t)(SpiTxBuf + SPI_TX_BUFFER_LEN- 1);
destEndPtr = (uint32_t>(&pADI_SPI0->TX);
ctrlCfg.Bits.r_power = 2; //2^2, 4 byte each frame
ctrlCfg.Bits.n_minus_1 = SPI_TX_BUFFER_LEN-1; //8 bytes in total
```

The frame continue bit of pADI_SPI0->CNT[15] must be set to 1 for continuous transfer.

In this case,

```
pADI_SPI0->CNT = 0x8004
```

Figure 29 shows a 20 kHz PLA signal triggered SPI frame. The baud rate of each byte is specified in the SPI module.

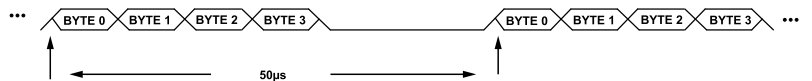

Figure 29. SPI Frame Triggered via PLA DMA (TRIG0 Channel)

ABORTING DMA TRANSFERS

It is possible to abort a DMA transfer that is in progress by writing to the bit of the appropriate channel in the ENCLR register. Configure the bit corresponding to the channel that needs to be aborted. Do not set CFG = 0 because this can corrupt the DMA structures.

FLASH DMA CHANNEL

DMA Channel 21 is the flash DMA channel.

The DMA supports keyhole writes to either Flash 0 or Flash 1. See [Table 90](#) for more details on enabling flash keyhole writes.

At the end of a flash channel DMA transfer, a flash DMA interrupt, if enabled, is asserted.

This interrupt, indicating that the DMA transfer is complete to the flash, does not mean the flash has been programmed. This is especially true if user code is running user code from Flash 0 or Flash 1 while the DMA write is to the other flash block. After the flash write is initiated, an additional 50 µs is required before the flash busy status flag goes inactive to show the flash write command has fully completed. See Bit 0 in [Table 78](#) for more details.

REGISTER SUMMARY: DMA

Table 268. DMA Register Summary

Address	Name	Description	Reset	Access
0x40040000	STAT	DMA Status.	0x001E0000	R
0x40040004	CFG	DMA Configuration.	0x00000000	W

DIRECT MEMORY ACCESS (DMA) CONTROLLER

Table 268. DMA Register Summary (Continued)

Address	Name	Description	Reset	Access
0x40040008	PDBPTR	DMA Channel Primary Control Data Base Pointer.	0x00000000	R/W
0x4004000C	ADBPTR	DMA Channel Alternate Control Data Base Pointer.	0x00000200	R
0x40040014	SWREQ	DMA Channel Software Request.	0x00000000	W
0x40040020	RMSKSET	DMA Channel Request Mask Set.	0x00000000	R/W
0x40040024	RMSKCLR	DMA Channel Request Mask Clear.	0x00000000	W
0x40040028	ENSET	DMA Channel Enable Set.	0x00000000	R/W
0x4004002C	ENCLR	DMA Channel Enable Clear.	0x00000000	W
0x40040030	ALTSET	DMA Channel Primary Alternate Set.	0x00000000	R/W
0x40040034	ALTCLR	DMA Channel Primary Alternate Clear.	0x00000000	W
0x40040038	PRASET	DMA Channel Priority Set.	0x00000000	W
0x4004003C	PRICLR	DMA Channel Priority Clear.	0x00000000	W
0x40040048	ERRCHNLCLR	DMA per Channel Error Clear.	0x00000000	R/W
0x4004004C	ERRCLR	DMA Bus Error Clear.	0x00000000	R/W
0x40040050	INVALIDDESCCLR	DMA per Channel Invalid Descriptor Clear.	0x00000000	R/W
0x40040800	BSSET	DMA Channel Bytes Swap Enable Set.	0x00000000	R/W
0x40040804	BSCLR	DMA Channel Bytes Swap Enable Clear.	0x00000000	W
0x40040810	SRCADDRSET	DMA Channel Source Address Decrement Enable Set.	0x00000000	R/W
0x40040814	SRCADDRCLR	DMA Channel Source Address Decrement Enable Clear.	0x00000000	W
0x40040818	DSTADDRSET	DMA Channel Destination Address Decrement Enable Set.	0x00000000	R/W
0x4004081C	DSTADDRCLR	DMA Channel Destination Address Decrement Enable Clear.	0x00000000	W
0x40040FE0	REVID	DMA Controller Revision ID.	0x00000002	R

REGISTER SUMMARY: DMA REQUEST

Table 269. DMA Request Register Summary

Address	Name	Description	Reset	Access
0x40007000	REQEN	General-Purpose Timers (16-Bit and 32-Bit) and PLA DMA Request Enable.	0x00	R/W
0x40007004	REQ0SEL	General-Purpose Timers (16-Bit and 32-Bit) and PLA DMA Request 0 Select.	0x00	R/W
0x40007008	REQ1SEL	General-Purpose Timers (16-Bit and 32-Bit) and PLA DMA Request 1 Select.	0x00	R/W
0x4000700C	PLAREQEN	PLA DMA Requests Enable.	0x00	R/W
0x40007010	GPTREQEN	General-Purpose Timers (16-Bit and 32-Bit) DMA Requests Enable.	0x00	R/W
0x40007014	GPT_MDA_REQ_TTYPE	General-Purpose Timers (16-Bit and 32-Bit) Trigger Type.	0x0000	R/W

REGISTER DETAILS: DMA

DMA Status Register

Address: 0x40040000, Reset: 0x001E0000, Name: STAT

Table 270. Bit Descriptions for STAT

Bits	Bit Name	Settings	Description	Reset	Access
[31:21]	RESERVED		Reserved.	0x0	R
[20:16]	CHANM1		Number of Available DMA Channels Minus 1. With 31 channels available, the register reads back 0x1E.	0x1E	R
[15:1]	RESERVED		Reserved.	0x0	R
0	MEN		Enable Status of the Controller.	0x0	R

DIRECT MEMORY ACCESS (DMA) CONTROLLER**DMA Configuration Register**

Address: 0x40040004, Reset: 0x00000000, Name: CFG

Table 271. Bit Descriptions for CFG

Bits	Bit Name	Settings	Description	Reset	Access
[31:1]	RESERVED		Reserved.	0x0	R
0	MEN		Controller Enable.	0x0	W

DMA Channel Primary Control Data Base Pointer Register

Address: 0x40040008, Reset: 0x00000000, Name: PDBPTR

The DMA PDBPTR register must be programmed to point to the primary channel control base pointer in the system memory. The amount of system memory that must be assigned to the DMA controller depends on the number of DMA channels used and whether the alternate channel control data structure is used. This register cannot be read when the DMA controller is in the reset state.

Table 272. Bit Descriptions for PDBPTR

Bits	Bit Name	Settings	Description	Reset	Access
[31:0]	ADDR		Pointer to the Base Address of the Primary Data Structure. $5 + \log_2(M)$ LSBs are reserved and must be written 0. M is number of channels.	0x0	R/W

DMA Channel Alternate Control Data Base Pointer Register

Address: 0x4004000C, Reset: 0x00000200, Name: ADBPTR

The DMA ADBPTR read only register returns the base address of the alternate channel control data structure. This register removes the necessity for application software to calculate the base address of the alternate data structure. This register cannot be read when the DMA controller is in the reset state.

Table 273. Bit Descriptions for ADBPTR

Bits	Bit Name	Settings	Description	Reset	Access
[31:0]	ADDR		Base Address of the Alternate Data Structure	0x200	R

DMA Channel Software Request Register

Address: 0x40040014, Reset: 0x00000000, Name: SWREQ

The DMA SWREQ register enables the generation of software DMA requests. Each bit of the register represents the corresponding channel number in the DMA controller. M is the number of DMA channels.

Table 274. Bit Descriptions for SWREQ

Bits	Bit Name	Settings	Description	Reset	Access
31	RESERVED		Reserved.	0x0	R
[30:0]	CHAN		Generate Software Request. Set the appropriate bit to generate a software DMA request on the corresponding DMA channel. Bit 0 corresponds to DMA Channel 0. Bit M - 1 corresponds to DMA Channel M - 1. CHAN[C] = 0, does not create a DMA request for Channel C. CHAN[C] = 1, generates a DMA request for Channel C. These bits are automatically cleared by the hardware after the corresponding software request completes.	0x0	W

DIRECT MEMORY ACCESS (DMA) CONTROLLER

DMA Channel Request Mask Set Register

Address: 0x40040020, Reset: 0x00000000, Name: RMSKSET

Table 275. Bit Descriptions for RMSKSET

Bits	Bit Name	Settings	Description	Reset	Access
31	RESERVED		Reserved.	0x0	R
[30:0]	CHAN		Mask Requests from DMA Channels. This register disables DMA requests from peripherals. Each bit of the register represents the corresponding channel number in the DMA controller. Set the appropriate bit to mask the request from the corresponding DMA channel. Bit 0 corresponds to DMA Channel 0. Bit M - 1 corresponds to DMA Channel M - 1. 0 When read: CHAN[C] = 0, requests are enabled for Channel C. When written: CHAN[C] = 0, no effect. 1 When read: CHAN[C] = 1, requests are disabled for Channel C. When written: CHAN[C] = 1, disables the peripheral associated with Channel C from generating DMA requests. Use the DMA RMSKSET register to enable DMA requests.	0x0	R/W

DMA Channel Request Mask Clear Register

Address: 0x40040024, Reset: 0x00000000, Name: RMSKCLR

Table 276. Bit Descriptions for RMSKCLR

Bits	Bit Name	Settings	Description	Reset	Access
31	RESERVED		Reserved.	0x0	R
[30:0]	CHAN		Clear REQ_MASK_SET Bits in DMA RMSKSET. This register enables DMA requests from peripherals by clearing the mask set in the DMA RMSKSET register. Each bit of the register represents the corresponding channel number in the DMA controller. Set the appropriate bit to clear the corresponding CHAN bit in the DMA RMSKSET register. Bit 0 corresponds to DMA Channel 0. Bit M - 1 corresponds to DMA Channel M - 1. 0 When written: CHAN[C] = 0, no effect. Use the RMSKSET register to disable DMA requests. 1 When written: CHAN[C] = 1, enables peripheral associated with Channel C to generate DMA requests.	0x0	W

DMA Channel Enable Set Register

Address: 0x40040028, Reset: 0x00000000, Name: ENSET

Table 277. Bit Descriptions for ENSET

Bits	Bit Name	Settings	Description	Reset	Access
31	RESERVED		Reserved.	0x0	R
[30:0]	CHAN		Enable DMA Channels. This register allows the enabling of DMA channels. Reading the register returns the enable status of the channels. Each bit of the register represents the corresponding channel number in the DMA controller. Set the appropriate bit to enable the corresponding channel. Bit 0 corresponds to DMA Channel 0. Bit M - 1 corresponds to DMA Channel M - 1. When read: CHAN[C] = 0, Channel C is disabled. CHAN[C] = 1, Channel C is enabled. When written: CHAN[C] = 0, no effect. CHAN[C] = 1, Channel C is enabled. Use the DMA ENCLR register to disable the channel. CHAN[C] = 1 enables Channel C.	0x0	R/W

DMA Channel Enable Clear Register

Address: 0x4004002C, Reset: 0x00000000, Name: ENCLR

Table 278. Bit Descriptions for ENCLR

Bits	Bit Name	Settings	Description	Reset	Access
31	RESERVED		Reserved.	0x0	R
[30:0]	CHAN		Disable DMA Channels. This register allows the disabling of DMA channels. This register is write only. Each bit of the register represents the corresponding channel number in the DMA controller. The controller disables a channel automatically by setting the appropriate bit, when it completes the DMA	0x0	W

DIRECT MEMORY ACCESS (DMA) CONTROLLER

Table 278. Bit Descriptions for ENCLR (Continued)

Bits	Bit Name	Settings	Description	Reset	Access
			cycle. Set the appropriate bit to disable the corresponding channel. Bit 0 corresponds to DMA Channel 0. Bit M – 1 corresponds to DMA Channel M – 1. When written: CHAN[C] = 0, no effect. CHAN[C] = 1, disables Channel C. Use the DMA ENSET register to enable the channel.		

DMA Channel Primary Alternate Set Register

Address: 0x40040030, Reset: 0x00000000, Name: ALTSET

The DMA ALTSET register enables the user to configure the appropriate DMA channel to use the alternate control data structure. Reading the register returns the status of the data structure in use for the corresponding DMA channel. Each bit of the register represents the corresponding channel number in the DMA controller.

The DMA controller sets or clears these bits automatically as necessary for ping pong, memory scatter gather, and peripheral scatter gather transfers.

Table 279. Bit Descriptions for ALTSET

Bits	Bit Name	Settings	Description	Reset	Access
31	RESERVED		Reserved.	0x0	R
[30:0]	CHAN		Control Structure Status or Select Alt Structure. Returns the channel control data structure status or selects the alternate data structure for the corresponding DMA channel. Bit 0 corresponds to DMA Channel 0. Bit M – 1 corresponds to DMA Channel M – 1. When read: CHAN[C] = 0, DMA Channel C is using the primary data structure. CHAN[C] = 1, DMA Channel C is using the alternate data structure. When written: CHAN[C] = 0, no effect. Use the DMA ALTCLR register to set CHAN[C] to 0. Setting CHAN[C] = 1 selects the alternate data structure for Channel C.	0x0	R/W

DMA Channel Primary Alternate Clear Register

Address: 0x40040034, Reset: 0x00000000, Name: ALTCLR

The DMA ALTCLR write only register allows the user to configure the appropriate DMA channel to use the primary control data structure. Each bit of the register represents the corresponding channel number in the DMA controller.

The DMA controller sets or clears these bits automatically as necessary for ping pong, memory scatter gather, and peripheral scatter gather transfers.

Table 280. Bit Descriptions for ALTCLR

Bits	Bit Name	Settings	Description	Reset	Access
31	RESERVED		Reserved.	0x0	R
[30:0]	CHAN		Select Primary Data Structure. Set the appropriate bit to select the primary data structure for the corresponding DMA channel. Bit 0 corresponds to DMA Channel 0. Bit M – 1 corresponds to DMA Channel M – 1. When written: CHAN[C] = 0, no effect. Use the DMA_ALTSET register to select the alternate data structure. Setting CHAN[C] = 1 selects the primary data structure for Channel C.	0x0	W

DMA Channel Priority Set Register

Address: 0x40040038, Reset: 0x00000000, Name: PRISET

Table 281. Bit Descriptions for PRISET

Bits	Bit Name	Settings	Description	Reset	Access
31	RESERVED		Reserved.	0x0	R

DIRECT MEMORY ACCESS (DMA) CONTROLLER

Table 281. Bit Descriptions for PRISET (Continued)

Bits	Bit Name	Settings	Description	Reset	Access
[30:0]	CHAN		<p>Configure Channel for High Priority. This register configures the priority level of a DMA channel. Reading the register returns the status of the channel priority mask. Each bit of the register represents the corresponding channel number in the DMA controller. Bit 0 corresponds to DMA Channel 0. Bit M – 1 corresponds to DMA Channel M – 1.</p> <p>When read: CHAN[C] = 0, DMA Channel C is using the default priority level. CHAN[C] = 1, DMA Channel C is using the high priority level.</p> <p>When written: CHAN[C] = 0, no effect. CHAN[C] = 1 sets Channel C to the high priority level. Use the DMA_PRICLR register to set Channel C to the default priority level.</p>	0x0	W

DMA Channel Priority Clear Register

Address: 0x4004003C, Reset: 0x00000000, Name: PRICLR

Table 282. Bit Descriptions for PRICLR

Bits	Bit Name	Settings	Description	Reset	Access
31	RESERVED		Reserved.	0x0	R
[30:0]	CHPRICLR		<p>Configure Channel for Default Priority Level. The DMA PRICLR write only register enables the user to configure a DMA channel to use the default priority level. Each bit of the register represents the corresponding channel number in the DMA controller. Set the appropriate bit to select the default priority level for the specified DMA channel. Bit 0 corresponds to DMA Channel 0. Bit M – 1 corresponds to DMA Channel M – 1.</p> <p>When set to 0, no effect. Use the DMA PRISET register to set Channel C to the high priority level. When set to 1, Channel C uses the default priority level.</p>	0x0	W

DMA Per Channel Error Clear Register

Address: 0x40040048, Reset: 0x00000000, Name: ERRCHNLCLR

Table 283. Bit Descriptions for ERRCHNLCLR

Bits	Bit Name	Settings	Description	Reset	Access
31	RESERVED		Reserved.	0x0	R
[30:0]	CHAN		<p>Bus Error Status. This register is used to read and clear the DMA bus error status. The error status is set if the controller encountered a bus error while performing a transfer or when it reads an invalid descriptor (whose cycle control is 0b000). If a bus error occurs or an invalid cycle control is read on a channel, that channel is automatically disabled by the controller. The other channels are unaffected. Write 1 to clear bits.</p> <p>0 When read as 0, no bus error or an invalid cycle control has occurred. When written to 0, no effect.</p> <p>1 When read as 1, a bus error or invalid cycle control is pending. When written to 1, bit is cleared.</p>	0x0	R/W1C

DMA Bus Error Clear Register

Address: 0x4004004C, Reset: 0x00000000, Name: ERRCLR

Table 284. Bit Descriptions for ERRCLR

Bits	Bit Name	Settings	Description	Reset	Access
31	RESERVED		Reserved.	0x0	R
[30:0]	CHAN		<p>Bus Error Status. This register is used to read and clear the DMA bus error status. The error status is set if the controller encountered a bus error while performing a transfer. If a bus error occurs or invalid cycle control is read on a channel, that channel is automatically disabled by the controller. The other channels are unaffected. Write one to clear bits.</p> <p>When read: 0 = no bus error or invalid cycle control occurred. 1 = a bus error or invalid cycle control is pending.</p> <p>When written: 0 = no effect. 1 = bit is cleared.</p>	0x0	R/W1C

DIRECT MEMORY ACCESS (DMA) CONTROLLER**DMA Per Channel Invalid Descriptor Clear Register**

Address: 0x40040050, Reset: 0x00000000, Name: INVALIDDESCCLR

Table 285. Bit Descriptions for INVALIDDESCCLR

Bits	Bit Name	Settings	Description	Reset	Access
31	RESERVED		Reserved.	0x0	R
[30:0]	CHAN		Per Channel Invalid Descriptor Status Clear. This register is used to read and clear the per channel DMA invalid descriptor status. The per channel invalid descriptor status is set if the controller reads an invalid descriptor (whose cycle control is 0b000). If it reads an invalid cycle control for a channel, that channel is automatically disabled by the controller. The other channels are unaffected. Write one to clear bits. When read: 0 = no invalid cycle control occurred. 1 = an invalid cycle control is pending. When written: 0 = no effect. 1 = bit is cleared.	0x0	R/W1C

DMA Channel Bytes Swap Enable Set Register

Address: 0x40040800, Reset: 0x00000000, Name: BSSET

Table 286. Bit Descriptions for BSSET

Bits	Bit Name	Settings	Description	Reset	Access
31	RESERVED		Reserved.	0x0	R
[30:0]	CHAN		Byte Swap Status. This register is used to configure a DMA channel to use byte swap. Each bit of the register represents the corresponding channel number in the DMA controller. Bit 0 corresponds to DMA Channel 0. Bit M – 1 corresponds to DMA Channel M – 1. 0 When read as 0, Channel C byte swap is disabled. When written as 0, no effect. 1 When read as 1, Channel C byte swap is enabled. When written as 1, byte swap on Channel C is enabled.	0x0	R/W

DMA Channel Bytes Swap Enable Clear Register

Address: 0x40040804, Reset: 0x00000000, Name: BSCLR

Table 287. Bit Descriptions for BSCLR

Bits	Bit Name	Settings	Description	Reset	Access
31	RESERVED		Reserved.	0x0	R
[30:0]	CHAN		Disable Byte Swap. The DMA BSCLR write only register enables the user to configure a DMA channel to not use byte swapping and use the default operation. Each bit of the register represents the corresponding channel number in the DMA controller. 0 No effect. Use the BSSET register to enable byte swap on Channel C. 1 Disables byte swap on Channel C.	0x0	W

DMA Channel Source Address Decrement Enable Set Register

Address: 0x40040810, Reset: 0x00000000, Name: SRCADDRSET

Table 288. Bit Descriptions for SRCADDRSET

Bits	Bit Name	Settings	Description	Reset	Access
31	RESERVED		Reserved.	0x0	R
[30:0]	CHAN		Source Address Decrement Status and Configuration. The DMA SRCADDRSET register is used to configure the source address of a DMA channel to decrement the address instead of incrementing the address after each access. Each bit of the register represents the corresponding channel number in the DMA controller. Bit 0 corresponds to DMA Channel 0. Bit M – 1 corresponds to DMA Channel M – 1. 0 When read as 0, Channel C source address decrement is disabled. When written as 0, no effect. Use the SRCADDRCLR register to disable the source address decrement on Channel C.	0x0	R/W

DIRECT MEMORY ACCESS (DMA) CONTROLLER**Table 288. Bit Descriptions for SRCADDRSET (Continued)**

Bits	Bit Name	Settings	Description	Reset	Access
			1 When read as 1, Channel C source address decrement is enabled. When written as 1, source address decrement on Channel C is enabled.		

DMA Channel Source Address Decrement Enable Clear Register

Address: 0x40040814, Reset: 0x00000000, Name: SRCADDRCLR

Table 289. Bit Descriptions for SRCADDRCLR

Bits	Bit Name	Settings	Description	Reset	Access
31	RESERVED		Reserved.	0x0	R
[30:0]	CHAN		Disable Source Address Decrement. The DMA SRCADDRCLR write only register enables the user to configure a DMA channel to use the default source address in decrement mode. Each bit of the register represents the corresponding channel number in the DMA controller. Bit 0 corresponds to DMA Channel 0. Bit M – 1 corresponds to DMA Channel M – 1. 0 No effect. Use the SRCADDRSET register to enable source address decrement on Channel C. 1 Disables address source decrement on Channel C.	0x0	W

DMA Channel Destination Address Decrement Enable Set Register

Address: 0x40040818, Reset: 0x00000000, Name: DSTADDRSET

Table 290. Bit Descriptions for DSTADDRSET

Bits	Bit Name	Settings	Description	Reset	Access
31	RESERVED		Reserved.	0x0	R
[30:0]	CHAN		Destination Address Decrement Status. The DSTADDRSET register is used to configure the destination address of a DMA channel to decrement the address instead of incrementing the address after each access. Each bit of the register represents the corresponding channel number in the DMA controller. Bit 0 corresponds to DMA Channel 0. Bit M – 1 corresponds to DMA Channel M – 1. 0 When read as 0, Channel C destination address decrement is disabled. When written as 0, no effect. Use the DSTADDRCLR register to disable destination address decrement on Channel C. 1 When read as 1, Channel C destination address decrement is enabled. When written as 1, destination address decrement on Channel C is enabled.	0x0	R/W

DMA Channel Destination Address Decrement Enable Clear Register

Address: 0x4004081C, Reset: 0x00000000, Name: DSTADDRCLR

Table 291. Bit Descriptions for DSTADDRCLR

Bits	Bit Name	Settings	Description	Reset	Access
31	RESERVED		Reserved.	0x0	R
[30:0]	CHAN		Disable Destination Address Decrement. The DSTADDRCLR write only register enables the user to configure a DMA channel to use the default destination address in increment mode. Each bit of the register represents the corresponding channel number in the DMA controller. Bit 0 corresponds to DMA Channel 0. Bit M – 1 corresponds to DMA Channel M – 1. 0 No effect. Use the DSTADDRSET register to enable destination address decrement on Channel C. 1 Disables destination address decrement on Channel C.	0x0	W

DMA Controller Revision ID Register

Address: 0x40040FE0, Reset: 0x00000002, Name: REVID

Table 292. Bit Descriptions for REVID

Bits	Bit Name	Settings	Description	Reset	Access
[31:8]	RESERVED		Reserved.	0x0	R

DIRECT MEMORY ACCESS (DMA) CONTROLLER**Table 292. Bit Descriptions for REVID (Continued)**

Bits	Bit Name	Settings	Description	Reset	Access
[7:0]	DMAREVID		DMA Controller Revision ID.	0x2	R

**REGISTER DETAILS: DMA REQUEST
PLA DMA Request Enable Register**

Address: 0x40007000, Reset: 0x00, Name: REQEN

Table 293. Bit Descriptions for REQEN

Bits	Bit Name	Settings	Description	Reset	Access
[7:2]	RESERVED		Reserved.	0x0	R
1	GPLA_DMA_EN1		General-Purpose Timers (16-Bit and 32-Bit) and PLA DMA Request 1. 0 Disable. 1 Enable.	0x0	R/W
0	GPLA_DMA_EN0		General-Purpose Timers (16-Bit and 32-Bit) and PLA DMA Request 0. 0 Disable. 1 Enable.	0x0	R/W

General-Purpose Timers (16-Bit and 32-Bit) and PLA DMA Request 0 Select Register

Address: 0x40007004, Reset: 0x00, Name: REQ0SEL

Table 294. Bit Descriptions for REQ0SEL

Bits	Bit Name	Settings	Description	Reset	Access
[7:4]	RESERVED		Reserved.	0x0	R
[3:0]	DMA_REQ0_SEL		General-Purpose Timers (16-Bit and 32-Bit) and PLA DMA Request 0 Source Select. 0 PLA DMA Request 0. 1 PLA DMA Request 1. 10 PLA DMA Request 2. 11 PLA DMA Request 3. 100 GPT0 DMA Request. 101 GPT1 DMA Request. 110 GPT2 DMA Request. 111 32-Bit Timer 0 DMA Request. 1000 32-Bit Timer 1 DMA Request. 1001 to 1111 Reserved.	0x0	R/W

General-Purpose Timers (16-Bit and 32-Bit) and PLA DMA Request 1 Select Register

Address: 0x40007008, Reset: 0x00, Name: REQ1SEL

Table 295. Bit Descriptions for REQ1SEL

Bits	Bit Name	Settings	Description	Reset	Access
[7:4]	RESERVED		Reserved.	0x0	R
[3:0]	DMA_REQ1_SEL		General-Purpose Timers (16-Bit and 32-Bit) and PLA DMA Request 1 Source Select. 0 PLA DMA Request 0. 1 PLA DMA Request 1. 10 PLA DMA Request 2. 11 PLA DMA Request 3. 100 GPT0 DMA Request. 101 GPT1 DMA Request. 110 GPT2 DMA Request.	0x0	R/W

DIRECT MEMORY ACCESS (DMA) CONTROLLER**Table 295. Bit Descriptions for REQ1SEL (Continued)**

Bits	Bit Name	Settings	Description	Reset	Access
		111	32-Bit Timer 0 DMA Request.		
		1000	32-Bit Timer 1 DMA Request.		
		1001 to 1111	Reserved.		

PLA DMA Requests Enable Register

Address: 0x4000700C, Reset: 0x00, Name: PLAREQEN

Table 296. Bit Descriptions for PLAREQEN

Bits	Bit Name	Settings	Description	Reset	Access
[7:4]	RESERVED		Reserved.	0x0	R
3	PLA_DMA_REQ3_EN		PLA DMA Request 3. 0 Disable. 1 Enable.	0x0	R/W
2	PLA_DMA_REQ2_EN		PLA DMA Request 2. 0 Disable. 1 Enable.	0x0	R/W
1	PLA_DMA_REQ1_EN		PLA DMA Request 1. 0 Disable. 1 Enable.	0x0	R/W
0	PLA_DMA_REQ0_EN		PLA DMA Request 0. 0 Disable. 1 Enable.	0x0	R/W

General-Purpose Timers (16-Bit and 32-Bit) DMA Requests Enable Register

Address: 0x40007010, Reset: 0x00, Name: GPTREQEN

Table 297. Bit Descriptions for GPTREQEN

Bits	Bit Name	Settings	Description	Reset	Access
[7:5]	RESERVED		Reserved.	0x0	R
4	GPT32_DMA_REQ1_EN		32-Bit Timer 1 DMA Request. 0 Disable. 1 Enable.	0x0	R/W
3	GPT32_DMA_REQ0_EN		32-Bit Timer 0 DMA Request. 0 Disable. 1 Enable.	0x0	R/W
2	GPT_DMA_REQ2_EN		16-Bit Timer 2 DMA Request. 0 Disable. 1 Enable.	0x0	R/W
1	GPT_DMA_REQ1_EN		16-Bit Timer 1 DMA Request. 0 Disable. 1 Enable.	0x0	R/W
0	GPT_DMA_REQ0_EN		16-Bit Timer 0 DMA Request. 0 Disable. 1 Enable.	0x0	R/W

DIRECT MEMORY ACCESS (DMA) CONTROLLER

General-Purpose Timers (16-Bit and 32-Bit) Trigger Type Register

Address: 0x40007014, Reset: 0x0000, Name: GPT_MDA_REQ_TTYPE

Table 298. Bit Descriptions for GPT_MDA_REQ_TTYPE

Bits	Bit Name	Settings	Description	Reset	Access
[15:10]	RESERVED		Reserved.	0x0	R
[9:8]	GPT32_REQ1_TYPE	00 01 10 11	32-Bit General-Purpose Timers Request 1 DMA Type. High Level Trigger Interrupt and High Level Trigger DMA Request. Rising Edge Trigger Interrupt and Rising Edge Trigger DMA Request. Low Level Trigger Interrupt and Low Level Trigger DMA Request. Falling Edge Trigger Interrupt and Falling Edge Trigger DMA Request.	0x0	R/W
[7:6]	GPT32_REQ0_TYPE	00 01 10 11	32-Bit General-Purpose Timers Request 0 DMA Type. High Level Trigger Interrupt and High Level Trigger DMA Request. Rising Edge Trigger Interrupt and Rising Edge Trigger DMA Request. Low Level Trigger Interrupt and Low Level Trigger DMA Request. Falling Edge Trigger Interrupt and Falling Edge Trigger DMA Request.	0x0	R/W
[5:4]	GPT_REQ2_TYPE	00 01 10 11	General-Purpose Timer Request 2 DMA Type. High Level Trigger Interrupt and High Level Trigger DMA Request. Rising Edge Trigger Interrupt and Rising Edge Trigger DMA Request. Low Level Trigger Interrupt and Low Level Trigger DMA Request. Falling Edge Trigger Interrupt and Falling Edge Trigger DMA Request.	0x0	R/W
[3:2]	GPT_REQ1_TYPE	00 01 10 11	General-Purpose Timer Request 1 DMA Type. High Level Trigger Interrupt and High Level Trigger DMA Request. Rising Edge Trigger Interrupt and Rising Edge Trigger DMA Request. Low Level Trigger Interrupt and Low Level Trigger DMA Request. Falling Edge Trigger Interrupt and Falling Edge Trigger DMA Request.	0x0	R/W
[1:0]	GPT_REQ0_TYPE	00 01 10 11	General-Purpose Timer Request 0 DMA Type. High Level Trigger Interrupt and High Level Trigger DMA Request. Rising Edge Trigger Interrupt and Rising Edge Trigger DMA Request. Low Level Trigger Interrupt and Low Level Trigger DMA Request. Falling Edge Trigger Interrupt and Falling Edge Trigger DMA Request.	0x0	R/W

PROGRAMMABLE LOGIC ARRAY (PLA)

PLA FEATURES

The ADuCM410 and ADuCM420 integrate a PLA that consists of two independent but interconnected PLA blocks. Each block consists of 16 PLA elements for a total of 32 elements: Element 0 to Element 31.

PLA OVERVIEW

Each PLA element contains a two-input lookup table that can be configured to generate any logic output function based on two inputs and a flip flop.

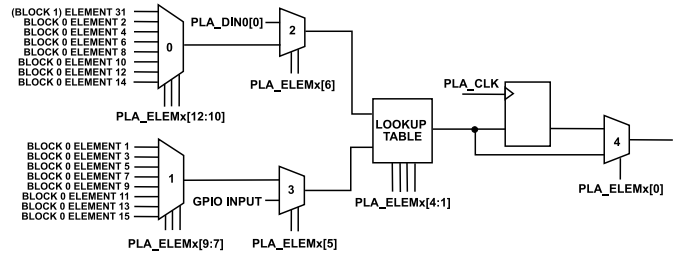
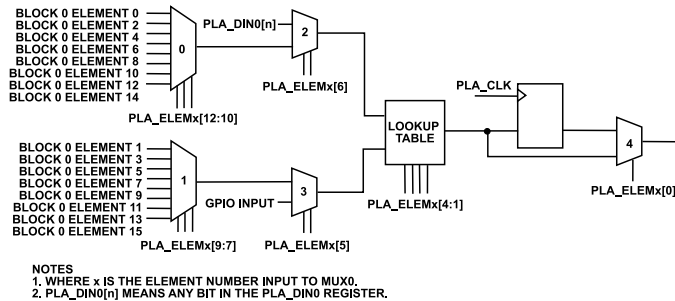
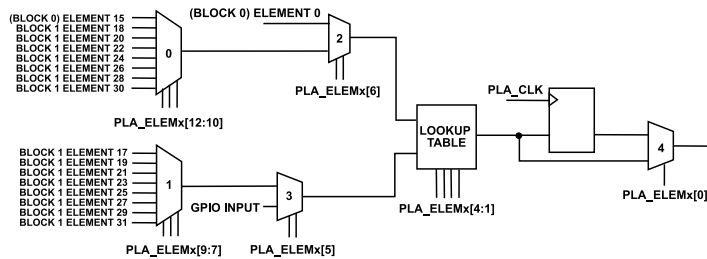

Figure 30. PLA Element: Block 0, Element 0



NOTES
 1. WHERE x IS THE ELEMENT NUMBER INPUT TO MUX0.
 2. PLA_DIN0[n] MEANS ANY BIT IN THE PLA_DINO REGISTER.

Figure 31. PLA Element: Block 0, Element 1 to Element 15



NOTES
 1. WHERE x IS THE ELEMENT NUMBER INPUT TO MUX0.

Figure 32. PLA Element: Block 1, Element 16

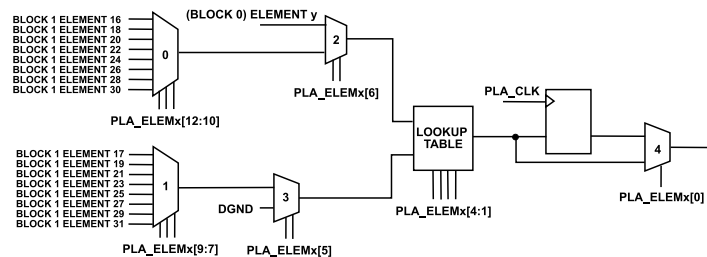

NOTES
 1. WHERE x IS THE ELEMENT NUMBER INPUT TO MUX0.
 2. WHERE y IS THE ELEMENT NUMBER INPUT TO MUX0 - 16.

Figure 33. PLA Element: Block 1, Element 17 to Element 27

PROGRAMMABLE LOGIC ARRAY (PLA)

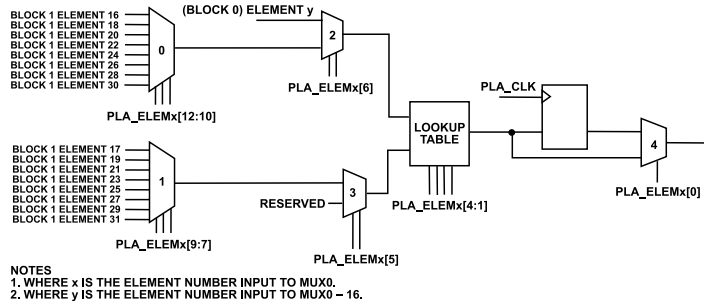

Figure 34. PLA Element: Block 1, Element 28 to Element 31

PLA OPERATION

The PLA is configured via a set of user MMRs. The outputs of the PLA can be routed to the internal interrupt system, to the PLA_DOUTx MMRs, or to any of the PLA output pins.

The GPIO inputs to the PLA are connected to their corresponding elements, when the GPxCON register for each pin is configured for PLA mode. The pin is also connected to the PLA when GPxCON = 0 and GPxIE/GPxOE = 1. Connection between the pin and PLA element is not guaranteed when GPxCON ≠ 0 and not configured for PLA operation.

A PLA block can have several clock sources for its output flip flops, or the flip flops can be individually bypassed. All output flip flops in the same block that are not bypassed share the same clock source. The configuration of the clock sources can be found in the PLA clock select register (PLA_CLK).

Each PLA element in a block can be connected to other elements in the same block by configuring the output of Mux 0 and Mux 1. The configuration of these two multiplexers can be found in the PLA_ELEMx configuration register. A complete list of the possible connections is given in Table 299 and Table 300.

The four blocks can be interconnected as shown in Figure 35.

There are two interrupts available for the PLA. These inputs can be configured to trigger the output of any element using the PLA_IRQ0 and PLA_IRQ1 registers. The interrupt levels are configurable for logic high, logic low, rising edge, or falling edge.

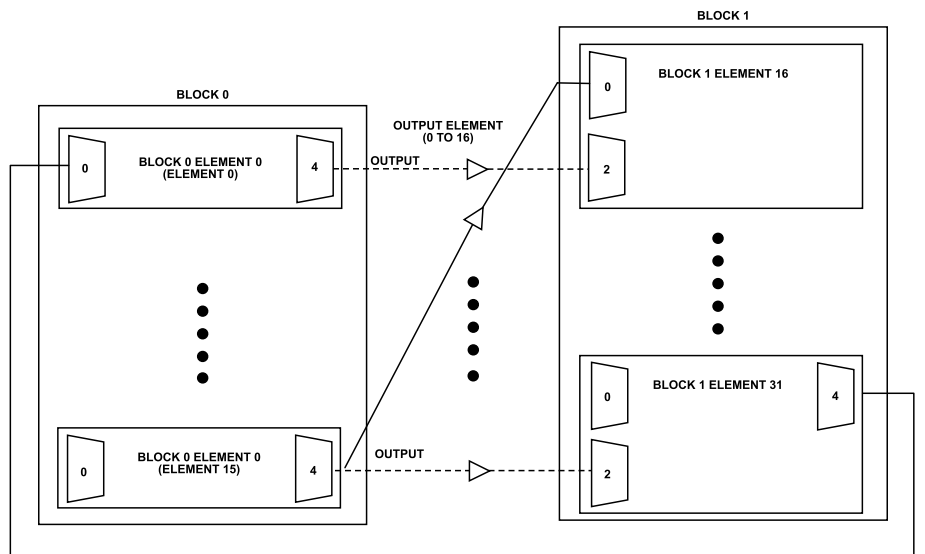

Figure 35. PLA Block 0 to Block 1 Interconnection

PROGRAMMABLE LOGIC ARRAY (PLA)

Table 299. Element GPIO Input/Output¹

PLA Block 0			PLA Block 1		
Element	Input	Output	Element	Input	Output
0	P0.0		16		
1	P0.1		17		
2	P0.2	P0.4	18		P2.4
3	P0.3	P0.5	19		P2.5
4	P1.0	P0.6	20		P2.6
5	P1.1	P0.7	21		P2.7
6	P1.2		22		
7	P1.3		23		
8	P2.0		24		
9	P2.1		25		
10	P2.3	P1.4	26		P3.4
11	P4.0	P1.5	27		P3.5
12	P3.0	P1.6	28	COMOUT0	P4.1
13	P3.1	P1.7	29	COMOUT1	P3.7
14	P3.2		30	COMOUT2	P3.6
15	P3.3		31	COMOUT3	

¹ Blank cells mean not applicable.

Table 300. Lookup Table Configuration

PLA_ELEMx, Bits[4:1]	Function
0000	0
0001	A NOR B
0010	\bar{A} AND B
0011	\bar{A}
0100	A AND \bar{B}
0101	\bar{B}
0110	A XOR B
0111	A NAND B
1000	A AND B
1001	A XNOR B
1010	B
1011	\bar{A} OR B
1100	A
1101	\bar{B}
1110	A OR B
1111	1

REGISTER SUMMARY: PLA

Table 301. PLA Register Summary

Address	Name	Description	Reset	Access
0x40006000 to 0x4000603C	PLA_ELEMx	Element Configuration Registers for Block 0, Element 0 to Element 15.	0x0000	R/W
0x40006040 to 0x4000607C	PLA_ELEMx	Element Configuration Registers for Block 1, Element 16 to Element 31.	0x0000	R/W
0x40006080	PLA_CLK	PLA Clock Select Register.	0x0000	R/W
0x40006084	PLA_IRQ0	Interrupt Register for Block 0.	0x0000	R/W
0x40006088	PLA_IRQ1	Interrupt Register for Block 1.	0x0000	R/W
0x4000608C	PLA_ADC	ADC Configuration Register.	0x0000	R/W
0x40006090	PLA_DIN0	Data Input for Block 0 Register.	0x0000	R/W

PROGRAMMABLE LOGIC ARRAY (PLA)

Table 301. PLA Register Summary (Continued)

Address	Name	Description	Reset	Access
0x40006098	PLA_DOUT0	Data Output for Block 0 Register.	0x0000	R
0x4000609C	PLA_DOUT1	Data Output for Block 1 Register.	0x0000	R
0x400060A0	PLA_LCK	Write Lock Register.	0x0000	R/W
0x400060A4	PLA_IRQTYPE	PLA Interrupt Request and DMA Request Type Register.	0x0000	R/W

REGISTER DETAILS: PLA

Element Configuration Registers for Block 0, Element 0 to Element 15

Address: 0x40006000 to 0x4000603C (Increments of 0x04), Reset: 0x0000, Name: PLA_ELEMx

Table 302. Bit Descriptions for PLA_ELEMx

Bits	Bit Name	Settings	Description	Reset	Access
[15:13]	RESERVED		Reserved.	0x0	R
[12:10]	MUX0	000 Feedback from Element 0 (all Except Element 0). If Element 0, input is from Block 1, Element 31. 001 Feedback from Element 2. 010 Feedback from Element 4. 011 Feedback from Element 6. 100 Feedback from Element 8. 101 Feedback from Element 10. 110 Feedback from Element 12. 111 Feedback from Element 14.	Mux for Even Element Feedback (in Respective Block).	0x0	R/W
[9:7]	MUX1	000 Feedback from Element 1. 001 Feedback from Element 3. 010 Feedback from Element 5. 011 Feedback from Element 7. 100 Feedback from Element 9. 101 Feedback from Element 11. 110 Feedback from Element 13. 111 Feedback from Element 15.	Mux for Odd Element Feedback (In Respective Block).	0x0	R/W
6	MUX2	0 PLA_DINx Input. 1 Even Feedback Mux.	Mux Between PLA_DINx Register or Even Feedback. Select Between Corresponding Bit from PLA_DINx Register or Even Feedback Mux.	0x0	R/W
5	MUX3	0 Odd Feedback Mux. 1 GPIO Input.	Mux Between GPIO Bus Input or Odd Feedback Input. Select Between GPIO Bus Input or Odd Feedback Input.	0x0	R/W
[4:1]	TBL	0000 0. 0001 NOR. 0010 B and Not A. 0011 NOT A. 0100 A and Not B. 0101 Not B. 0110 XOR. 0111 NAND. 1000 AND.	Lookup Table Configuration. Inputs from MUX2 and MUX3.	0x0	R/W

PROGRAMMABLE LOGIC ARRAY (PLA)

Table 302. Bit Descriptions for PLA_ELEMx (Continued)

Bits	Bit Name	Settings	Description	Reset	Access
		1001	XNOR.		
		1010	B.		
		1011	B or Not A.		
		1100	A.		
		1101	A or Not B.		
		1110	OR.		
		1111	1.		
0	MUX4		Select or Bypass Flip Flop Output.	0x0	R/W
		0	Flip Flop Output.		
		1	Bypass Output.		

Element Configuration Registers for Block 1, Element 16 to Element 31

Address: 0x40006040 to 0x4000607C (Increments of 0x04), Reset: 0x0000, Name: PLA_ELEMx

Table 303. Bit Descriptions for PLA_ELEMx

Bits	Bit Name	Settings	Description	Reset	Access
[15:13]	RESERVED		Reserved.	0x0	R
[12:10]	MUX0		Mux for Even Element Feedback (in Respective Block).	0x0	R/W
		000	Feedback from Element 16 (all Except Element 16). If Element 16, input is from Block 1, Element 15.		
		001	Feedback from Element 18.		
		010	Feedback from Element 20.		
		011	Feedback from Element 22.		
		100	Feedback from Element 24.		
		101	Feedback from Element 26.		
		110	Feedback from Element 28.		
		111	Feedback from Element 30.		
[9:7]	MUX1		Mux for Odd Element Feedback (In Respective Block).	0x0	R/W
		000	Feedback from Element 17.		
		001	Feedback from Element 19.		
		010	Feedback from Element 21.		
		011	Feedback from Element 23.		
		100	Feedback from Element 25.		
		101	Feedback from Element 27.		
		110	Feedback from Element 29.		
		111	Feedback from Element 31.		
6	MUX2		Mux Between PLA_DIN0 Register or Even Feedback. Select Between Corresponding Bit from Block 0 or Even Feedback Mux.	0x0	R/W
		0	Block 0 Feedback.		
		1	Even Feedback Mux.		
5	MUX3		Mux Between GPIO Bus Input or Odd Feedback Input for Block 1.	0x0	R/W
		0	Odd Feedback Mux.		
		1	GPIO Input/DGND/Reserved. See Figure 34 for Reference.		
[4:1]	TBL		Lookup Table Configuration. Inputs from MUX2 and MUX3.	0x0	R/W
		0000	0.		
		0001	NOR.		
		0010	B and Not A.		
		0011	NOT A.		
		0100	A and Not B.		

PROGRAMMABLE LOGIC ARRAY (PLA)

Table 303. Bit Descriptions for PLA_ELEMx (Continued)

Bits	Bit Name	Settings	Description	Reset	Access
		0101	Not B.		
		0110	EXOR.		
		0111	NAND.		
		1000	AND.		
		1001	EXNOR.		
		1010	B.		
		1011	B or Not A.		
		1100	A.		
		1101	A or Not B.		
		1110	OR.		
		1111	1.		
0	MUX4		Select or Bypass Flip Flop Output.	0x0	R/W
		0	Flip Flop Output.		
		1	Bypass Output.		

PLA Clock Select Register

Address: 0x40006080, Reset: 0x0000, Name: PLA_CLK

Table 304. Bit Descriptions for PLA_CLK

Bits	Bit Name	Settings	Description	Reset	Access
[15:7]	RESERVED		Reserved.	0x0	R
[6:4]	BLOCK1		Clock Select for Block 1.	0x0	R/W
		000	GPIO Clock on P0.3.		
		001	GPIO Clock on P0.2.		
		010	GPIO Clock on P4.7.		
		011	HCLK.		
		100	16 MHz Internal Oscillator.		
		101	Timer 0.		
		110	Timer 2.		
		111	32 kHz Internal Low Frequency Oscillator.		
3	RESERVED		Reserved.	0x0	R
[2:0]	BLOCK0		Clock Select for Block 0.	0x0	R/W
		000	GPIO Clock on P0.3.		
		001	GPIO Clock on P0.2.		
		010	GPIO Clock on P4.7.		
		011	HCLK.		
		100	16 MHz Internal Oscillator.		
		101	Timer 0.		
		110	Timer 2.		
		111	32 kHz Internal Low Frequency Oscillator.		

Interrupt Register for Block 0

Address: 0x40006084, Reset: 0x0000, Name: PLA_IRQ0

Table 305. Bit Descriptions for PLA_IRQ0

Bits	Bit Name	Settings	Description	Reset	Access
[15:13]	RESERVED		Reserved.	0x0	R
12	IRQ1_EN		IRQ1 Enable.	0x0	R/W
		0	Disable IRQ1 Interrupt.		
		1	Enable IRQ1 Interrupt.		

PROGRAMMABLE LOGIC ARRAY (PLA)**Table 305. Bit Descriptions for PLA_IRQ0 (Continued)**

Bits	Bit Name	Settings	Description	Reset	Access
[11:8]	IRQ1_SRC		IRQ1 Source Select (Element 0 to Element 15). 4-bit value corresponds to element number (for example, 1011 selects Element 11).	0x0	R/W
[7:5]	RESERVED		Reserved.	0x0	R
4	IRQ0_EN		IRQ0 Enable. 0 Disable IRQ0 Interrupt. 1 Enable IRQ0 Interrupt.	0x0	R/W
[3:0]	IRQ0_SRC		IRQ0 Source Select (Element 0 to Element 15). 4-bit value corresponds to element number (for example, 1011 selects Element 11).	0x0	R/W

Interrupt Register for Block 1

Address: 0x40006088, Reset: 0x0000, Name: PLA_IRQ1

Table 306. Bit Descriptions for PLA_IRQ1

Bits	Bit Name	Settings	Description	Reset	Access
[15:13]	RESERVED		Reserved.	0x0	R
12	IRQ3_EN		IRQ3 Enable. 0 Disable IRQ3 Interrupt. 1 Enable IRQ3 Interrupt.	0x0	R/W
[11:8]	IRQ3_SRC		IRQ3 Source Select (Element 16 to Element 31). Element number corresponds to 4-bit value + 16 (for example, 1011 selects Element 27).	0x0	R/W
[7:5]	RESERVED		Reserved.	0x0	R
4	IRQ2_EN		IRQ2 Enable. 0 Disable IRQ2 Interrupt. 1 Enable IRQ2 Interrupt.	0x0	R/W
[3:0]	IRQ2_SRC		IRQ2 Source Select (Element 16 to Element 31). Element number corresponds to 4-bit value + 16 (for example, 1011 selects Element 27).	0x0	R/W

ADC Configuration Register

Address: 0x4000608C, Reset: 0x0000, Name: PLA_ADC

Table 307. Bit Descriptions for PLA_ADC

Bits	Bit Name	Settings	Description	Reset	Access
[15:6]	RESERVED		Reserved.	0x0	R
5	CONVST_EN		Bit to Enable ADC Start Convert from PLA. 0 Disable. 1 Enable.	0x0	R/W
[4:0]	CONVST_SRC		Element for ADC Start Convert Source. The binary value corresponds to the element number. For example, Element 23 is 10111.	0x0	R/W

Data Input for Block 0 Register

Address: 0x40006090, Reset: 0x0000, Name: PLA_DIN0

Table 308. Bit Descriptions for PLA_DIN0

Bits	Bit Name	Settings	Description	Reset	Access
[15:0]	DIN		Input Bit to Element 15 to Element 0.	0x0	R/W

PROGRAMMABLE LOGIC ARRAY (PLA)

Data Output for Block 0 Register

Address: 0x40006098, Reset: 0x0000, Name: PLA_DOUT0

Table 309. Bit Descriptions for PLA_DOUT0

Bits	Bit Name	Settings	Description	Reset	Access
15	E15		Output Bit from Element 15	0x0	R
14	E14		Output Bit from Element 14	0x0	R
13	E13		Output Bit from Element 13	0x0	R
12	E12		Output Bit from Element 12	0x0	R
11	E11		Output Bit from Element 11	0x0	R
10	E10		Output Bit from Element 10	0x0	R
9	E9		Output Bit from Element 9	0x0	R
8	E8		Output Bit from Element 8	0x0	R
7	E7		Output Bit from Element 7	0x0	R
6	E6		Output Bit from Element 6	0x0	R
5	E5		Output Bit from Element 5	0x0	R
4	E4		Output Bit from Element 4	0x0	R
3	E3		Output Bit from Element 3	0x0	R
2	E2		Output Bit from Element 2	0x0	R
1	E1		Output Bit from Element 1	0x0	R
0	E0		Output Bit from Element 0	0x0	R

Data Output for Block 1 Register

Address: 0x4000609C, Reset: 0x0000, Name: PLA_DOUT1

Table 310. Bit Descriptions for PLA_DOUT1

Bits	Bit Name	Settings	Description	Reset	Access
15	E31		Output Bit from Element 31	0x0	R
14	E30		Output Bit from Element 30	0x0	R
13	E29		Output Bit from Element 29	0x0	R
12	E28		Output Bit from Element 28	0x0	R
11	E27		Output Bit from Element 27	0x0	R
10	E26		Output Bit from Element 26	0x0	R
9	E25		Output Bit from Element 25	0x0	R
8	E24		Output Bit from Element 24	0x0	R
7	E23		Output Bit from Element 23	0x0	R
6	E22		Output Bit from Element 22	0x0	R
5	E21		Output Bit from Element 21	0x0	R
4	E20		Output Bit from Element 20	0x0	R
3	E19		Output Bit from Element 19	0x0	R
2	E18		Output Bit from Element 18	0x0	R
1	E17		Output Bit from Element 17	0x0	R
0	E16		Output Bit from Element 16	0x0	R

PROGRAMMABLE LOGIC ARRAY (PLA)**Write Lock Register**

Address: 0x400060A0, Reset: 0x0000, Name: PLA_LCK

Can only be set once every reset

Table 311. Bit Descriptions for PLA_LCK

Bits	Bit Name	Settings	Description	Reset	Access
[15:1]	RESERVED		Reserved.	0x0	R
0	LOCKED		Set to Disable Writing to Registers. 0 Writing to Registers Allowed. 1 Writing to Registers Disabled.	0x0	R/W/S

PLA Interrupt Request and DMA Request Type Register

Address: 0x400060A4, Reset: 0x0000, Name: PLA_IRQTYPE

Selects a high/low level or falling/rising edge as PLA interrupt type or the PLA to DMA trigger type.

Table 312. Bit Descriptions for PLA_IRQTYPE

Bits	Bit Name	Settings	Description	Reset	Access
[15:8]	RESERVED		Reserved.	0x0	R
[7:6]	IRQ3_TYPE		IRQ3 and DMA Request 3 Type. PLA interrupt Request 0 type select. 0 High Level Trigger Interrupt and High Level Trigger DMA Request. 1 Rising Edge and High Level Trigger DMA Request. 10 Reserved. 11 Falling Edge and Low Level Trigger DMA Request.	0x0	R/W
[5:4]	IRQ2_TYPE		IRQ2 and DMA Request 2 Type. PLA interrupt Request 0 type select. 0 High Level Trigger Interrupt and High Level Trigger DMA Request. 1 Rising Edge and High Level Trigger DMA Request. 10 Reserved. 11 Falling Edge and Low Level Trigger DMA Request.	0x0	R/W
[3:2]	IRQ1_TYPE		IRQ1 and DMA Request 1 Type. PLA interrupt Request 0 type select. 0 High Level Trigger Interrupt and High Level Trigger DMA Request. 1 Rising Edge and High Level Trigger DMA Request. 10 Reserved. 11 Falling Edge and Low Level Trigger DMA Request.	0x0	R/W
[1:0]	IRQ0_TYPE		IRQ0 and DMA Request 0 Type. PLA interrupt Request 0 type select. 0 High Level Trigger Interrupt and High Level Trigger DMA Request. 1 Rising Edge and High Level Trigger DMA Request. 10 Reserved. 11 Falling Edge and Low Level Trigger DMA Request.	0x0	R/W

DOWNLOADER

The ADuCM410 and ADuCM420 support both I²C and MDIO interfaces for downloading code to the microcontroller. If the P2.3/BM/PLAI10 pin is low, the ADuCM410 and ADuCM420 enter download mode via the BM function. The user selects either MDIO or I²C by configuring the P2.1/DM/IRQ2/ECLKIN/COMPdin3/PLAI9 pin (high for I²C, low for MDIO) via the DM function.

I²C DOWNLOADER

The ADuCM410 and ADuCM420 contain firmware that is inaccessible to the user but runs after every reset to set up the device and to allow programming of the device via the I²C interface on the P0.4/SCL0/SIN0/PLAO2 and P0.5/SDA0/SOUT0/PLAO3 pins. The mechanism to enter the downloader and the protocol used are described in the [AN-806 Application Note, Flash Programming via I²C—Protocol Type 5](#).

To enter I²C download mode, the P2.3/BM/PLAI10 pin must be low and the P2.1/DM/IRQ2/ECLKIN/COMPdin3/PLAI9 pin must be high during any reset sequence.

The relevant pins for I²C download mode include the following:

- ▶ P2.1/DM/IRQ2/ECLKIN/COMPdin3/PLAI9 selects the download mode type (0 = MDIO, 1 = I²C)
- ▶ P2.3/BM/PLAI10 P2.3 selects download mode (1 = user code executed, 0 = download mode)
- ▶ P0.4/SCL0/SIN0/PLAO2: I²C Channel 0 is used
- ▶ P0.5/SDA0/SOUT0/PLAO3: I²C Channel 0 is used

MDIO DOWNLOADER

To enter the MDIO downloader, the P2.3/BM/PLAI10 and P2.1/DM/IRQ2/ECLKIN/COMPdin3/PLAI9 pins must be pulled low during a reset sequence.

The relevant pins for MDIO download mode include the following:

- ▶ P2.1/DM/IRQ2/ECLKIN/COMPdin3/PLAI9 selects the download mode type (0 = MDIO, 1 = I²C)
- ▶ P2.3/BM/PLAI10 selects download mode (1 = user code executed, 0 = download mode)
- ▶ P3.5/MCK/SRDY1/PLAO27: MDIO slave clock function
- ▶ P3.6/MDIO/SRDY2/PLAO30: MDIO slave data function

PULSE WIDTH MODULATOR (PWM)

PWM FEATURES

The PWM features an 8-channel PWM interface, with H bridge mode supported on two pairs.

PWM OVERVIEW

The ADuCM410 and ADuCM420 integrate an 8-channel PWM interface. Eight channels are grouped as four pairs (0 to 3). The first two pairs of PWM outputs (PWM0, PWM1, PWM2, and PWM3) can be configured in standard mode or to drive an H bridge. Pair 2 and Pair 3 can only be configured in standard mode. The PWM pairs and modes are summarized in [Table 313](#).

Table 313. PWM Channel Grouping

Port Name	Description	PWM Mode Available
PWM0	High-side PWM output for Pair 0	H bridge and standard
PWM1	Low-side PWM output for Pair 0	H bridge and standard
PWM2	High-side PWM output for Pair 1	H bridge and standard
PWM3	Low-side PWM output for Pair 1	H bridge and standard
PWM4	High-side PWM output for Pair 2	Standard
PWM5	Low-side PWM output for Pair 2	Standard
PWM6	High-side PWM output for Pair 3	Standard
PWM7	Low-side PWM output for Pair 3	Standard

On power-up, the PWM outputs default to H bridge mode for Pair 0 and Pair 1. In the standard mode, users have control over the period of each pair of outputs and over the duty cycle of each individual output.

In the event of external fault conditions, a falling edge on the PWMTRIP signal provides an instantaneous shutdown of the PWM controller. All PWM outputs are placed in an off state (that is, in low state for the low side and high state for the high side), and a PWMTRIP interrupt can be generated.

PWM OPERATION

The PWM clock is selectable via the PWMCON0 register with one of the following values: PWM universal clock (PWM_UCLK) divided by 2, 4, 8, 16, 32, 64, 128, or 256.

In all modes, the PWMxCOMx MMRs control the point at which the PWM output changes state. An example is shown in [Figure 36](#).

Each pair has an associated counter. The PWMxLEN register defines the length of the PWM period.

The count value of the 16-bit timer and the compare register contents set the PWM waveforms.

An example for PWM Pair 0 (Port PWM0 and Port PWM1) is as follows:

- ▶ The low-side waveform (PWM1) goes high when the timer count reaches the value held in the PWM0LEN register, and it goes low when the timer count reaches the value held in the PWM0COM2 register or when the high-side waveform PWM0 goes low.
- ▶ The high-side waveform (PWM0) goes high when the timer count reaches the value held in the PWM0COM0 register, and it goes low when the timer count reaches the value held in the PWM0COM1 register.

PULSE WIDTH MODULATOR (PWM)

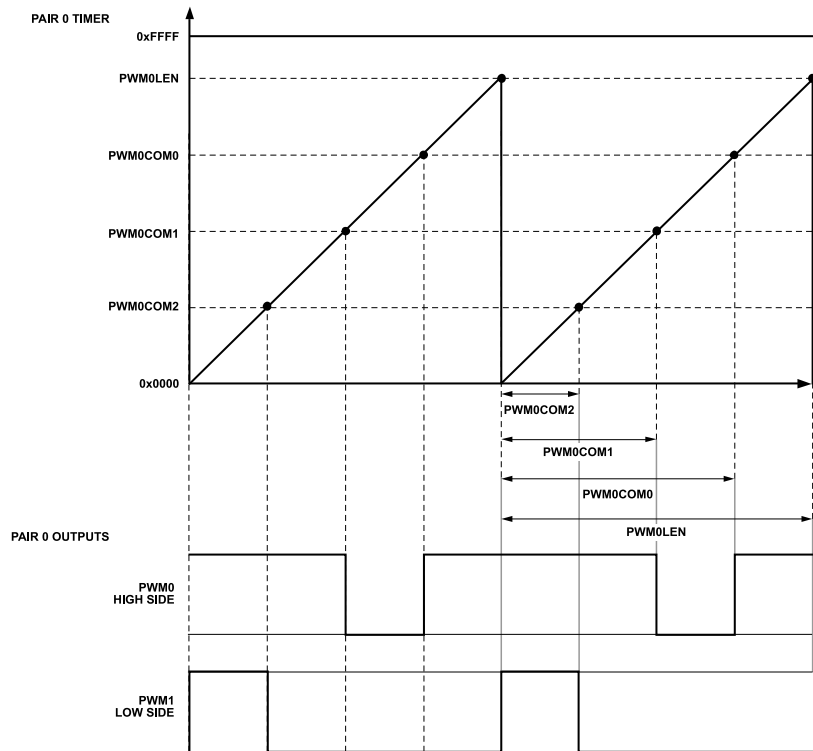

NOTES
 1. NOTE THAT THE HIGH-SIDE PWM OUTPUT FOR EACH CHANNEL MUST HAVE A HIGH DURATION PERIOD GREATER THAN OR EQUAL TO THE HIGH PERIOD DURATION OF THE LOW-SIDE OUTPUT. FOR EXAMPLE, THE HIGH PERIOD FOR PWM0 MUST BE GREATER THAN OR EQUAL TO THE HIGH PERIOD OF PWM1.

Figure 36. Waveform of PWM Channel Pair in Standard Mode

Table 314 lists equations for the period and duration for both the outputs of a PWM channel. $t_{P_{PWM_UCLK}}$ is the PWM clock period selected by CLKCON1, Bits[2:0], which divides UCLK. $N_{PRESCALE}$ is the prescaler value as determined by PWMCON0, Bits[8:6].

Table 314. PWM Equations

PWM	Period	Duration
Low Side (PWM1)	$t_{P_{PWM_UCLK}} \times (PWM0LEN + 1) \times N_{PRESCALE}$	For the high duration, if $PWM0COM2 < PWM0COM1$, then $t_{P_{PWM_UCLK}} \times (PWM0LEN - PWM0COM2) \times N_{PRESCALE}$. Otherwise, $t_{P_{PWM_UCLK}} \times (PWM0LEN - PWM0COM1) \times N_{PRESCALE}$.
High Side (PWM0)	$t_{P_{PWM_UCLK}} \times (PWM0LEN + 1) \times N_{PRESCALE}$	For low duration, $t_{P_{PWM_UCLK}} \times (PWM0COM0 - PWM0COM1) \times N_{PRESCALE}$.

Standard Mode

In standard mode, each pair is controlled individually by a selection of registers, as shown in Table 315.

Table 315. Compare Register Descriptions in Standard Mode (Base Address: 0x40064000)

Pair	Name	Description
0	PWM0COM0	PWM0 output goes high when the PWM timer reaches the count value stored in this register.
	PWM0COM1	PWM0 output goes low when the PWM timer reaches the count value stored in this register.
	PWM0COM2	PWM1 output goes low when the PWM timer reaches the count value stored in this register.
	PWM0LEN	PWM1 output goes high when the PWM timer reaches the count value stored in this register.
1	PWM1COM0	PWM2 output goes high when the PWM timer reaches the count value stored in this register.
	PWM1COM1	PWM2 output goes low when the PWM timer reaches the count value stored in this register.
	PWM1COM2	PWM3 output goes low when the PWM timer reaches the count value stored in this register.
	PWM1LEN	PWM3 output goes high when the PWM timer reaches the count value stored in this register.
2	PWM2COM0	PWM4 output goes high when the PWM timer reaches the count value stored in this register.
	PWM2COM1	PWM4 output goes low when the PWM timer reaches the count value stored in this register.

PULSE WIDTH MODULATOR (PWM)

Table 315. Compare Register Descriptions in Standard Mode (Base Address: 0x40064000) (Continued)

Pair	Name	Description
3	PWM2COM2	PWM5 output goes low when the PWM timer reaches the count value stored in this register.
	PWM2LEN	PWM5 output goes high when the PWM timer reaches the count value stored in this register.
	PWM3COM0	PWM6 output goes high when the PWM timer reaches the count value stored in this register.
3	PWM3COM1	PWM6 output goes low when the PWM timer reaches the count value stored in this register.
	PWM3COM2	PWM7 output goes low when the PWM timer reaches the count value stored in this register.
	PWM3LEN	PWM7 output goes high when the PWM timer reaches the count value stored in this register.

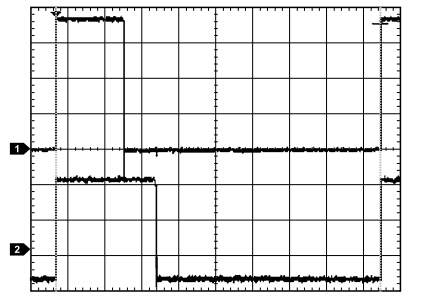

Figure 37. PWM Output on PWM0 and PWM1 (PWM Channel 2)

H Bridge Mode

In H bridge mode, the period and duty cycle of the four outputs are controlled using the Pair 0 registers: PWM0COM0, PWM0COM1, PWM0COM2, and PWM0LEN. In addition, Bit 9, Bit 5, Bit 4, and Bit 2 in the PWMCON0 register control the state of the output as summarized in Table 316.

An example of the H bridge configuration is shown in Figure 38. Note that only PWM0 to PWM3 participate in H bridge mode. Other outputs (PWM4 and PWM5) do not, and continue to generate the standard mode output.

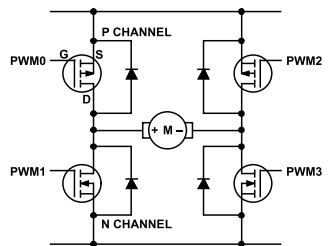

Figure 38. Example H Bridge Configuration

Table 316. PWM Output in H Bridge Mode

PWM Control Bit(s) in PWMCON0 ¹				PWM Outputs ²				State of Motor
ENA, Bit 9	POINV, Bit 5	HOFF, Bit 4	DIR, Bit 2	PWM0	PWM1	PWM2	PWM3	
0	X	0	X	1 (disable)	1 (enable)	1 (disable)	1 (enable)	Brake
X	X	1	X	1 (disable)	0 (disable)	1 (disable)	0 (disable)	Free run
1	0	0	0	0 (enable)	0 (disable)	High side	Low side	Move controlled by low side on PWM3
1	0	0	1	High side	Low side	0 (Enable)	0 (Disable)	Move controlled by low side on PWM1
1	1	0	0	Low side	High side	1 (Disable)	1 (Enable)	Move controlled by low side on PWM0
1	1	0	1	1 (disable)	1 (enable)	Low side	High side	Move controlled by low side on PWM2

¹ X is don't care.

² High side is the inverse of high side, and Low side is the inverse of low side, as programmed in the PWM0 registers.

PULSE WIDTH MODULATOR (PWM)

PWM INTERRUPT GENERATION

PWM Trip Function Interrupt

When the PWM trip function is enabled (TRIP_EN, PWMCON1, Bit 6) and the PWM trip input signal goes high (rising edge), the PWM peripheral disables itself (PWMCON0, Bit 0 = 0) and generates the PWM trip interrupt. The interrupt is cleared by setting PWMCLRI, Bit 4.

When using the PWM trip interrupt, clear the PWM interrupt before exiting the ISR to prevent the generation of multiple interrupts.

PWM Output Pairs Interrupts

In standard mode, each PWM pair has a dedicated interrupt: IRQPWM0, IRQPWM1, or IRQPWM2.

When the interrupt generation is enabled (PWMCON0, Bit 10) and the counter value for Pair 0 changes from PWM0LEN to 0, the PWM also generates the IRQPWM0 interrupt. The interrupt is cleared by setting PWMCLRI, Bit 0.

When the interrupt generation is enabled (PWMCON0, Bit 10) and the counter value for Pair 1 changes from PWM1LEN to 0, the PWM also generates the IRQPWM1 interrupt. The interrupt is cleared by setting PWMCLRI, Bit 1.

When the interrupt generation is enabled (PWMCON0, Bit 10) and the counter value for Pair 2 changes from PWM2LEN to 0, the PWM also generates the IRQPWM2 interrupt. The interrupt is cleared by setting PWMCLRI, Bit 2.

When the interrupt generation is enabled (PWMCON0, Bit 10) and the counter value for Pair 3 changes from PWM3LEN to 0, the PWM also generates the IRQPWM3 interrupt. The interrupt is cleared by setting PWMCLRI, Bit 3.

In H bridge mode, Pair 0 and Pair 1 are used in the bridge configuration and generate one interrupt only, IRQPWM0. While Pair 0 and Pair 1 are in H bridge mode, Pair 2 can be used in standard mode, and they can generate the IRQPWM2 interrupt.

REGISTER SUMMARY: PWM

Table 317. PWM Register Summary

Address	Name	Description	Reset	RW
0x40064000	PWMCON0	PWM control register	0x0012	RW
0x40064004	PWMCON1	ADC conversion start and trip control register	0x0000	RW
0x40064008	PWMICLR	Hardware trip configuration register	0x0000	RW1C
0x40064010	PWM0COM0	Compare Register 0 for PWM0 and PWM1	0x0000	RW
0x40064014	PWM0COM1	Compare Register 1 for PWM0 and PWM1	0x0000	RW
0x40064018	PWM0COM2	Compare Register 2 for PWM0 and PWM1	0x0000	RW
0x4006401C	PWM0LEN	Period value register for PWM0 and PWM1	0x0000	RW
0x40064020	PWM1COM0	Compare Register 0 for PWM2 and PWM3	0x0000	RW
0x40064024	PWM1COM1	Compare Register 1 for PWM2 and PWM3	0x0000	RW
0x40064028	PWM1COM2	Compare Register 2 for PWM2 and PWM3	0x0000	RW
0x4006402C	PWM1LEN	Period value register for PWM2 and PWM3	0x0000	RW
0x40064030	PWM2COM0	Compare Register 0 for PWM4 and PWM5	0x0000	RW
0x40064034	PWM2COM1	Compare Register 1 for PWM4 and PWM5	0x0000	RW
0x40064038	PWM2COM2	Compare Register 2 for PWM4 and PWM5	0x0000	RW
0x4006403C	PWM2LEN	Period value register for PWM4 and PWM5	0x0000	RW
0x40064040	PWM3COM0	Compare Register 0 for PWM6 and PWM7	0x0000	RW
0x40064044	PWM3COM1	Compare Register 1 for PWM6 and PWM7	0x0000	RW
0x40064048	PWM3COM2	Compare Register 2 for PWM6 and PWM7	0x0000	RW
0x4006404C	PWM3LEN	Period value register for PWM6 and PWM7	0x0000	RW

PULSE WIDTH MODULATOR (PWM)

REGISTER DETAILS: PWM

PWM Control Register

Address: 0x40064000, Reset: 0x0012, Name: PWMCON0

Table 318. Bit Descriptions for PWMCON0

Bit(s)	Bit Name	Setting	Description	Reset	Access
15	SYNC		Set to enable PWM synchronization from PWMSYNC. 0 Ignore transition from PWMSYNC. 1 All PWM counters are reset on the next clock cycle after detection of a falling edge from PWMSYNC.	0x0	RW
14	PWM5INV		Set to invert PWM7 output.	0x0	RW
13	PWM5INV		Set to invert PWM5 output.	0x0	RW
12	PWM3INV		Set to invert PWM3 output.	0x0	RW
11	PWM1INV		Set to invert PWM1 output.	0x0	RW
10	PWMIEN		Set to enable interrupts for PWM.	0x0	RW
9	ENA		When HOFF = 0 and HMODE = 1, this bit serves as an enable for Pair 0 and Pair 1. 0 Disable Pair 0 and Pair 1. 1 Enable Pair 0 and Pair 1.	0x0	RW
[8:6]	PWMCMP		PWM clock prescaler. Sets HCLK (UCLK) divider. 000 PWM_UCLK/2. 001 PWM_UCLK/4. 010 PWM_UCLK/8. 011 PWM_UCLK/16. 100 PWM_UCLK/32. 101 PWM_UCLK/64. 110 PWM_UCLK/128. 111 PWM_UCLK/256.	0x0	RW
5	POINV		Set to invert PWM outputs for Pair 0 and Pair 1 when PWM is in H bridge mode.	0x0	RW
4	HOFF		Set to turn off the high side for Pair 0 and Pair 1 when PWM is in H bridge mode.	0x1	RW
3	LCOMP		Signal to load a new set of compare register values. In standard mode, this bit is cleared when the new values are loaded in the compare registers for all the channels. In H bridge mode, this bit is not cleared. However, the user must write a value of 1 to this bit for the compare registers to be loaded. 0 Use the values previously store in the compare and length registers. 1 Load the internal compare registers with values stored in the PWMxCOMx and PWMxLEN registers.	0x0	RW
2	DIR		Direction control when PWM is in H bridge mode. 0 PWM2 and PWM3 act as output signals while PWM0 and PWM1 are held low. 1 PWM0 and PWM1 act as output signals while PWM2 and PWM3 are held low.	0x0	RW
1	HMODE		Set to enable H bridge mode.	0x1	RW
0	PWMEN		Master enable for PWM. 0 Disable all PWM outputs. 1 Enable all PWM outputs.	0x0	RW

ADC Conversion Start and Trip Control Register

Address: 0x40064004, Reset: 0x0000, Name: PWMCON1

Table 319. Bit Descriptions for PWMCON1

Bit(s)	Bit Name	Description	Reset	Access
[15:7]	RESERVED	Reserved. Return 0 on reads.	0x00	Reserved
6	TRIP_EN	Set to enable PWM trip functionality.	0x0	RW
[5:0]	RESERVED	Reserved.	0x0	Reserved

PULSE WIDTH MODULATOR (PWM)**Hardware Trip Configuration Register**

Address: 0x40064008, Reset: 0x0000, Name: PWMICLR

Table 320. Bit Descriptions for PWMICLR

Bit(s)	Bit Name	Description	Reset	Access
[15:5]	RESERVED	Reserved. Return 0 on reads.	0x000	Reserved
4	TRIP	Write a 1 to clear latched IRQ PWM trip interrupt. Returns 0 on reads.	0x0	RW1C
3	PWM3	Write a 1 to clear latched IRQ PWM3 interrupt. Returns 0 on reads.	0x0	RW1C
2	PWM2	Write a 1 to clear latched IRQ PWM2 interrupt. Returns 0 on reads.	0x0	RW1C
1	PWM1	Write a 1 to clear latched IRQ PWM1 interrupt. Returns 0 on reads.	0x0	RW1C
0	PWM0	Write a 1 to clear latched IRQ PWM0 interrupt. Returns 0 on reads.	0x0	RW1C

Compare Register 0 for PWM0 and PWM1

Address: 0x40064010, Reset: 0x0000, Name: PWM0COM0

Table 321. Bit Descriptions for PWM0COM0

Bit(s)	Bit Name	Description	Reset	Access
[15:0]	COM0	Compare Register 0 data	0x0	RW

Compare Register 1 for PWM0 and PWM1

Address: 0x40064014, Reset: 0x0000, Name: PWM0COM1

Table 322. Bit Descriptions for PWM0COM1

Bit(s)	Bit Name	Description	Reset	Access
[15:0]	COM1	Compare Register 1 data	0x0	RW

Compare Register 2 for PWM0 and PWM1

Address: 0x40064018, Reset: 0x0000, Name: PWM0COM2

Table 323. Bit Descriptions for PWM0COM2

Bit(s)	Bit Name	Description	Reset	Access
[15:0]	COM2	Compare Register 2 data	0x0	RW

Period Value Register for PWM0 and PWM1

Address: 0x4006401C, Reset: 0x0000, Name: PWM0LEN

Table 324. Bit Descriptions for PWM0LEN

Bit(s)	Bit Name	Description	Reset	Access
[15:0]	LEN	Period value	0x0	RW

Compare Register 0 for PWM2 and PWM3

Address: 0x40064020, Reset: 0x0000, Name: PWM1COM0

Table 325. Bit Descriptions for PWM1COM0

Bit(s)	Bit Name	Description	Reset	Access
[15:0]	COM0	Compare Register 0 data	0x0	RW

PULSE WIDTH MODULATOR (PWM)**Compare Register 1 for PWM2 and PWM3**

Address: 0x40064024, Reset: 0x0000, Name: PWM1COM1

Table 326. Bit Descriptions for PWM1COM1

Bit(s)	Bit Name	Description	Reset	Access
[15:0]	COM1	Compare Register 1 data	0x0	RW

Compare Register 2 for PWM2 and PWM3

Address: 0x40064028, Reset: 0x0000, Name: PWM1COM2

Table 327. Bit Descriptions for PWM1COM2

Bit(s)	Bit Name	Description	Reset	Access
[15:0]	COM2	Compare Register 2 data	0x0	RW

Period Value Register for PWM2 and PWM3

Address: 0x4006402C, Reset: 0x0000, Name: PWM1LEN

Table 328. Bit Descriptions for PWM1LEN

Bit(s)	Bit Name	Description	Reset	Access
[15:0]	LEN	Period value	0x0	RW

Compare Register 0 for PWM4 and PWM5

Address: 0x40064030, Reset: 0x0000, Name: PWM2COM0

Table 329. Bit Descriptions for PWM2COM0

Bit(s)	Bit Name	Description	Reset	Access
[15:0]	COM0	Compare Register 0 data	0x0	RW

Compare Register 1 for PWM4 and PWM5

Address: 0x40064034, Reset: 0x0000, Name: PWM2COM1

Table 330. Bit Descriptions for PWM2COM1

Bits	Bit Name	Settings	Description	Reset	Access
[15:0]	PWM2COM1		Compare Register 1 for PWM4 and PWM5	0x0	R/W

Compare Register 2 for PWM4 and PWM5

Address: 0x40064038, Reset: 0x0000, Name: PWM2COM2

Table 331. Bit Descriptions for PWM2COM2

Bits	Bit Name	Settings	Description	Reset	Access
[15:0]	PWM2COM2		Compare Register 2 for PWM4 and PWM5	0x0	R/W

Period Value Register for PWM4 and PWM5

Address: 0x4006403C, Reset: 0x0000, Name: PWM2LEN

Table 332. Bit Descriptions for PWM2LEN

Bits	Bit Name	Settings	Description	Reset	Access
[15:0]	PWM2LEN		Period Value Register for PWM4 and PWM5	0x0	R/W

PULSE WIDTH MODULATOR (PWM)**Compare Register 0 for PWM6 and PWM7**

Address: 0x40064040, Reset: 0x0000, Name: PWM3COM0

Table 333. Bit Descriptions for PWM3COM0

Bits	Bit Name	Settings	Description	Reset	Access
[15:0]	PWM3COM0		Compare Register 0 for PWM6 and PWM7	0x0	R/W

Compare Register 1 for PWM6 and PWM7

Address: 0x40064044, Reset: 0x0000, Name: PWM3COM1

Table 334. Bit Descriptions for PWM3COM1

Bits	Bit Name	Settings	Description	Reset	Access
[15:0]	PWM3COM1		Compare Register 1 for PWM6 and PWM7	0x0	R/W

Compare Register 2 for PWM6 and PWM7

Address: 0x40064048, Reset: 0x0000, Name: PWM3COM2

Table 335. Bit Descriptions for PWM3COM2

Bits	Bit Name	Settings	Description	Reset	Access
[15:0]	PWM3COM2		Compare Register 2 for PWM6 and PWM7	0x0	R/W

Period Value Register for PWM6 and PWM7

Address: 0x4006404C, Reset: 0x0000, Name: PWM3LEN

Table 336. Bit Descriptions for PWM3LEN

Bits	Bit Name	Settings	Description	Reset	Access
[15:0]	PWM3LEN		Period Value Register for PWM6 and PWM7	0x0	R/W

Compare Register 1 for PWM4 and PWM5

Address: 0x40064034, Reset: 0x0000, Name: PWM2COM1

Table 337. Bit Descriptions for PWM2COM1

Bit(s)	Bit Name	Description	Reset	Access
[15:0]	COM1	Compare Register 1 data	0x0	RW

Compare Register 2 for PWM4 and PWM5

Address: 0x40064038, Reset: 0x0000, Name: PWM2COM2

Table 338. Bit Descriptions for PWM2COM2

Bit(s)	Bit Name	Description	Reset	Access
[15:0]	COM2	Compare Register 2 data	0x0	RW

Period Value Register for PWM4 and PWM5

Address: 0x4006403C, Reset: 0x0000, Name: PWM2LEN

Table 339. Bit Descriptions for PWM2LEN

Bit(s)	Bit Name	Description	Reset	Access
[15:0]	LEN	Period value	0x0	RW

CYCLIC REDUNDANCY CHECK

The CRC accelerator computes the CRC for a block of memory locations. The exact memory location can be in the SRAM, flash, or any combination of memory mapped registers. The CRC accelerator generates a checksum that can be compared to an expected signature. The final CRC comparison is the responsibility of the MCU.

CRC FEATURES

The CRC used by the ADuCM410 and ADuCM420 MCU supports the following features:

- ▶ Generation of a CRC signature for a block of data.
- ▶ Programmable polynomial length of up to 32 bits.
- ▶ Operates on 32 bits of data at a time.
- ▶ MSB first and LSB first CRC implementations.
- ▶ Various data mirroring capabilities.
- ▶ Initial seed to be programmed by user.
- ▶ DMA controller (using software DMA) can be used for data transfer to offload workload from the MCU.

CRC FUNCTIONAL DESCRIPTION

The following sections detail the functionality of the CRC. Control for address decrement and increment options for computing the CRC on a block of memory is in the DMA controller.

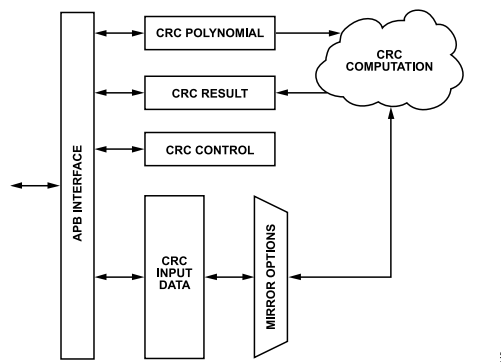

Figure 39. CRC Block Diagram

CRC Architectural Concepts

The CRC accelerator works on 32-bit data words, which are written to the block by the MCU. The CRC accelerator guarantees immediate availability of the CRC output.

CRC Operating Modes

The accelerator calculates CRC on the data stream it receives, 32 bits at a time. The CRC is then written into the block by the MCU directly.

The CRC works on 32-bit data words. For data words less than 32 bits in size, the MCU must pack the data into 32-bit data units. Data mirroring on the input data can be performed at bit, byte, or word level (only for 32-bit data) by setting the CTL register, Bits[4:2].

When operating, the CRC algorithm runs on the incoming data stream written to the IPDATA register. For every new word of data received, the CRC is computed, and the result register is updated with the calculated CRC. The CRC accelerator guarantees the immediate availability of the CRC result up to the current data in the result register.

The CRC engine uses the current result for generating the next result when a new data word is received. The result register can be programmed with an initial seed. The bit width of the seed value for an x-bit polynomial must be x. The seed must be justified in the result register.

CYCLIC REDUNDANCY CHECK

Polynomial

The CRC accelerator supports the calculation of the CRC using any length polynomial. The polynomial must be written to the polynomial register. For MSB first implementation, omit the highest power while programming the CRC polynomial register and left justify the polynomial. For LSB first implementation, right justify the polynomial and omit the LSB. The result register contains x-bit MSBs as a checksum for an x-bit CRC polynomial.

The following examples illustrate the CRC polynomial.

16-Bit Polynomial Programming for MSB First Calculation: CRC-16-CCITT

The 16-bit polynomial for MSB first calculation is

$$x^{16} + x^{12} + x^5 + 1 = (1) 0001\ 0000\ 0010\ 0001 = 0x1021 \quad (36)$$

where the largest exponent (x^{16} term) is implied. Therefore, the polynomial is 0001 0000 0010 0001.

When left justified in the polynomial register, the register format is detailed in [Table 340](#).

Table 340. 16-Bit Polynomial Programming Register Format, MSB First Calculation

Register	Bit(s)	Value
CRC Polynomial Register (POLY)	[31:24]	0001 0000
	[23:16]	0010 0001
	[15:8]	0x08B0
	[7:0]	0x08B0
CRC Result Register (Result)	[31:24]	CRC
	[23:16]	Result
	[15:8]	0x08B0
	[7:0]	0x08B0
Initial Seed Programmed in CRC Result Register (Result)	[31:24]	CRC
	[23:16]	Seed
	[15:8]	0x08B0
	[7:0]	0x08B0

16-Bit Polynomial Programming for LSB First Calculation: CRC-16-CCITT

The 16-bit polynomial for LSB first calculation is

$$x^{16} + x^{12} + x^5 + 1 = 1000\ 0100\ 0000\ 1000 (1) = 0x8408 \quad (37)$$

where the smallest exponent (x^0 term) is implied. Therefore, the polynomial is 1000 0100 0000 1000.

When right justified in the polynomial register, the register format is detailed in [Table 341](#).

Table 341. 16-Bit Polynomial Programming Register Format, LSB First Calculation

Register	Bit(s)	Value
CRC Polynomial Register (POLY)	[31:24]	0x08B0
	[23:16]	0x08B0
	[15:8]	1000 0100
	[7:0]	0000 1000
CRC Result Register (Result)	[31:24]	0x08B0
	[23:16]	0x08B0
	[15:8]	CRC
	[7:0]	Result
Initial Seed Programmed in CRC Result Register (Result)	[31:24]	0x08B0
	[23:16]	0x08B0
	[15:8]	CRC

CYCLIC REDUNDANCY CHECK

Table 341. 16-Bit Polynomial Programming Register Format, LSB First Calculation (Continued)

Register	Bit(s)	Value
	[7:0]	Seed

8-Bit Polynomial Programming for MSB First Calculation: CRC-8-ATM

The 8-bit polynomial for MSB first calculation is

$$x^8 + x^2 + x + 1 = (1) 0000 0111 = 0x07 \quad (38)$$

where the largest exponent (x^8 term) is implied. Therefore, the polynomial is 0000 0111.

When left justified in the polynomial register, the register format is detailed in Table 342.

Table 342. 8-Bit Polynomial Programming Register Format, MSB First Calculation

Register	Bit(s)	Value
CRC Polynomial Register (POLY)	[31:24]	0000 0111
	[23:16]	0x08B0
	[15:8]	0x08B0
	[7:0]	0x08B0
CRC Result Register (Result)	[31:24]	CRC result
	[23:16]	0x08B0
	[15:8]	0x08B0
	[7:0]	0x08B0
Initial Seed Programmed in CRC Result Register (Result)	[31:24]	CRC seed
	[23:16]	0x08B0
	[15:8]	0x08B0
	[7:0]	0x08B0

8-Bit Polynomial Programming for LSB First Calculation: CRC-8-ATM

The 8-bit polynomial for LSB first calculation is

$$x^8 + x^2 + x + 1 = 1000 0011 (1) = 0x83 \quad (39)$$

where the smallest exponent (x^0 term) is implied. Therefore, the polynomial is 1000 0011.

When right justified in the polynomial register, the register format is detailed in Table 343.

Table 343. 8-Bit Polynomial Programming Register Format, LSB First Calculation

Register	Bit(s)	Value
CRC Polynomial Register (POLY)	[31:24]	0x08B0
	[23:16]	0x08B0
	[15:8]	0x08B0
	[7:0]	1000 0011
CRC Result Register (Result)	[31:24]	0x08B0
	[23:16]	0x08B0
	[15:8]	0x08B0
	[7:0]	CRC result
Initial Seed Programmed in CRC Result Register (Result)	[31:24]	0x08B0
	[23:16]	0x08B0
	[15:8]	0x08B0
	[7:0]	CRC seed

The CRC engine uses the following 32-bit CRC polynomial as the default (as per the IEEE 802.3 standard):

$$g(x) = x^{32} + x^{26} + x^{23} + x^{22} + x^{16} + x^{12} + x^{11} + x^{10} + x^8 + x^7 + x^5 + x^4 + x^2 + x + 1 \quad (40)$$

CYCLIC REDUNDANCY CHECK

This value is programmed for MSB first calculation by default as shown in [Table 344](#).

Table 344. Default CRC Polynomial Register (POLY) Value

Bit(s)	Value
[31:24]	0x04
[23:16]	0xC1
[15:8]	0x1D
[7:0]	0xB7

Reset and Hibernate Modes

The CRC configuration bits are retained, except for the block enable bit (CTL, Bit 0). The block must be enabled again after exiting hibernate mode. The CRC polynomial and CRC result registers are retained after exiting hibernate mode. See [Table 345](#) for details on the CRC registers after a reset and in hibernate mode.

Table 345. Reset and Hibernate by Register

Register	Reset	Hibernate
CTL	0x10000000	Apart from the EN bit, all other bits retained
POLY	0x04C11DB7	Retained
IPDATA	0x0	Not retained
Result	0x0	Retained

CRC DATA TRANSFER

The data stream can be written to the block using the MCU directly.

CRC PROGRAMMING MODEL

The CRC block is provided to calculate the CRC signature over a block of data in the background while the core performs other tasks.

Core Access Steps

To access the core, take the following steps:

1. Program the POLY register with the required polynomial justified, as detailed in the [Polynomial](#) section.
2. Program the result register with the initial seed. The seed must be justified and written to the result register, as detailed in the [Polynomial](#) section.
3. Enable accelerator function by writing to the CTL register. Note that the following steps require a single write to the CTL register:
 - a. Set the EN bit high.
 - b. Modify the W16SWP, BYTMIRR, and BITMIRR bits in the CTL register, which configure the application with different mirroring options. For more information, see the [Mirroring Options](#) section.
 - c. Set or reset the LSBFIRST bit to indicate whether to use LSB first or MSB first in CRC calculation.

The core can start sending data to the CRC block by writing into the IPDATA register. The CRC accelerator continues to calculate the CRC if data is written to the IPDATA register. The application is responsible for counting the number of words written to the CRC block. After all the words are written, the application can read the result register.

4. Read the result register. This register contains the x-bit result in x MSB bits for MSB first and in x LSB bits for LSB first CRC calculation.
5. Calculate CRC on the next data block. To calculate the CRC on the next block of data, repeat Step 1 to Step 4.
6. Disable the CRC accelerator block by clearing the EN bit in CTL to ensure that the block is in a low power state.

CYCLIC REDUNDANCY CHECK

Mirroring Options

The W16SWP, BITMIRR, and BYTMIRR bits in CTL determine the sequence of the bits in which the CRC is calculated. Table 346 details all the mirroring options used within the CRC block for a 32-bit polynomial.

DIN, Bits[31:0] is the data being written to the IPDATA register, and CIN, Bits[31:0] is the data after the mirroring of the data. The serial engine calculates CIN, Bits[31:0] starting with the MSB bit and ending with LSB bit in sequence (CIN, Bit 31 to CIN, Bit 0 in descending order).

Table 346. Mirroring Options for 32-Bit Input Data (DIN) with 32-Bit Polynomial

W16SWP	BYTMIRR	BITMIRR	DIN, Bits[31:0]	CRC Input Data (CIN, Bits[31:0])
0	0	0	DIN, Bits[31:0]	CIN, Bits[31:0] = DIN, Bits[31:0]
0	0	1	DIN, Bits[31:0]	CIN, Bits[31:0] = DIN, Bits[24:31]; DIN, Bits[16:23]; DIN, Bits[8:15]; DIN, Bits[0:7]
0	1	0	DIN, Bits[31:0]	CIN, Bits[31:0] = DIN, Bits[23:16]; DIN, Bits[31:24]; DIN, Bits[7:0]; DIN, Bits[15:8]
0	1	1	DIN, Bits[31:0]	CIN, Bits[31:0] = DIN, Bits[16:23]; DIN, Bits[24:31]; DIN, Bits[0:7]; DIN, Bits[8:15]
1	0	0	DIN, Bits[31:0]	CIN, Bits[31:0] = DIN, Bits[15:0]; DIN, Bits[31:16]
1	0	1	DIN, Bits[31:0]	CIN, Bits[31:0] = DIN, Bits[8:15]; DIN, Bits[0:7]; DIN, Bits[24:31]; DIN, Bits[16:23]
1	1	0	DIN, Bits[31:0]	CIN, Bits[31:0] = DIN, Bits[7:0]; DIN, Bits[15:8]; DIN, Bits[23:16]; DIN, Bits[31:24]
1	1	1	DIN, Bits[31:0]	CIN, Bits[31:0] = DIN, Bits[0:7]; DIN, Bits[8:15]; DIN, Bits[16:23]; DIN, Bits[24:31]

REGISTER SUMMARY: CRC

Table 347. CRC Register Summary

Address	Name	Description	Reset	Access
0x40040000	CTL	CRC control register	0x10000000	R/W
0x40040004	IPDATA	Input data word register	0x00000000	W
0x40040008	RESULT	CRC result register	0x00000000	R/W
0x4004000C	POLY	Programmable CRC polynomial	0x04C11DB7	R/W

REGISTER DETAILS: CRC

CRC Control Register

Address: 0x40040000, Reset: 0x10000000, Name: CTL

Table 348. Bit Descriptions for CTL

Bits	Bit Name	Settings	Description	Reset	Access
[31:28]	REVID		Revision ID.	0x1	R
[27:5]	Reserved		Reserved.	0x0	R
4	W16SWP		Word 16-Bit Swap. This bit swaps 16-bit half words within a 32-bit word. 0 Word 16-bit swap disabled. 1 Word 16-bit swap enabled.	0x0	R/W
3	BYTMIRR		Byte Mirroring. This bit swaps 8-bit bytes within each 16-bit half word. 0 Byte mirroring is disabled. 1 Byte mirroring is enabled.	0x0	R/W
2	BITMIRR		Bit Mirroring. This bit swaps bits within each byte. 0 Bit mirroring is disabled. 1 Bit mirroring is enabled.	0x0	R/W
1	LSBFIRST		LSB First Calculation Order. 0 MSB first CRC calculation. 1 LSB first CRC calculation.	0x0	R/W
0	EN		CRC Peripheral Enable. 0 CRC peripheral is disabled. 1 CRC peripheral is enabled.	0x0	R/W

CYCLIC REDUNDANCY CHECK**Input Data Word Register**

Address: 0x40040004, Reset: 0x00000000, Name: IPDATA

Table 349. Bit Descriptions for IPDATA

Bits	Bit Name	Settings	Description	Reset	Access
[31:0]	VALUE		Data Input.	0x0	W

CRC Result Register

Address: 0x40040008, Reset: 0x00000000, Name: RESULT

Table 350. Bit Descriptions for RESULT

Bits	Bit Name	Settings	Description	Reset	Access
[31:0]	VALUE		CRC Reset.	0x0	R/W

Programmable CRC Polynomial Register

Address: 0x4004000C, Reset: 0x04C11DB7, Name: POLY

Table 351. Bit Descriptions for POLY

Bits	Bit Name	Settings	Description	Reset	Access
[31:0]	VALUE		CRC Reduction Polynomial.	0x4C11DB7	R/W

SILICON IDENTIFICATION

This section gives details of the silicon revision number tracking via CHIPID, Bits[3:0] and other details.

The automated test equipment (ATE) test program, kernel revisions, and unique chip ID number can be read from the read only locations detailed in [Table 352](#).

The kernel revision number uses the following format:

- ▶ Bits[15:12] = silicon revision number, starting from 1 with the first revision of silicon.
- ▶ Bits[11:4] = kernel major revision number. For prerelease silicon, this is ASCII for a letter.
- ▶ Bits[3:0] = kernel minor revision number. Number between 0 and 0xF, starting from 0xF and decrementing with newer minor revisions.

For example, if the value read from 0x101FE8 = 0x258d, this translates to BXd as follows:

- ▶ 2 = B (second silicon revision)
- ▶ 0x58 = ASCII X (kernel major revision)
- ▶ d = d (kernel minor revision)

Table 352. Kernel and ATE Test Program Revision Details

Address	Name	Description	Access
0x101FE8	Kernel revision number	16-bit value	R
0x101FEC	ATE test program revision	16-bit value	R
0x101FF0	6-byte unique part ID number	6-byte value	R

REGISTER SUMMARY: SILICON IDENTIFICATION

Table 353. Silicon Identification Register Summary

Address	Name	Description	Reset	Access
0x40002020	ADIID	Analog Devices ID Register	0x00000000	R
0x40002024	CHIPID	Chip ID Register	0x00000000	R
0x40002134	USERKEY0	Open to Customer to Protect Important Registers	0x00000000	W

REGISTER DETAILS: SILICON IDENTIFICATION

Analog Devices ID Register

Address: 0x40002020, Reset: 0x00000000, Name: ADIID

Table 354. Bit Descriptions for ADIID

Bits	Bit Name	Settings	Description	Reset	Access
[31:16]	RESERVED		Reserved.	0x0	R
[15:0]	ADIID		Analog Devices ID. The fixed value of 0x4144 is presented at this register.	0x4144	R

Chip ID Register

Address: 0x40002024, Reset: 0x00000571, Name: CHIPID

Table 355. Bit Descriptions for CHIPID

Bits	Bit Name	Settings	Description	Reset	Access
[31:16]	RESERVED		Reserved.	0x0	R
[15:4]	PARTID		Part Identifier.	0x57	R
[3:0]	REVISION		Silicon Revision Number.	0x1	R

SILICON IDENTIFICATION

Open to Customer to Protect Important Registers

Address: 0x40002134, Reset: 0x00000000, Name: USERKEY0

Table 356. Bit Descriptions for USERKEY0

Bits	Bit Name	Settings	Description	Reset	Access
[31:0]	KEY		User Key. Unlock: write 0x8D5F9FEC. Lock: write 0x0.	0x0	W

I²C refers to a communications protocol originally developed by Philips Semiconductors (now NXP Semiconductors).



ESD Caution

ESD (electrostatic discharge) sensitive device. Charged devices and circuit boards can discharge without detection. Although this product features patented or proprietary protection circuitry, damage may occur on devices subjected to high energy ESD. Therefore, proper ESD precautions should be taken to avoid performance degradation or loss of functionality.

Legal Terms and Conditions

Information furnished by Analog Devices is believed to be accurate and reliable. However, no responsibility is assumed by Analog Devices for its use, nor for any infringements of patents or other rights of third parties that may result from its use. No license is granted by implication or otherwise under any patent or patent rights of Analog Devices. Trademarks and registered trademarks are the property of their respective owners. Information contained within this document is subject to change without notice. Software or hardware provided by Analog Devices may not be disassembled, decompiled or reverse engineered. Analog Devices' standard terms and conditions for products purchased from Analog Devices can be found at: http://www.analog.com/en/content/analog_devices_terms_and_conditions/fca.html