

PCB LAYOUT
(TOP VIEW)

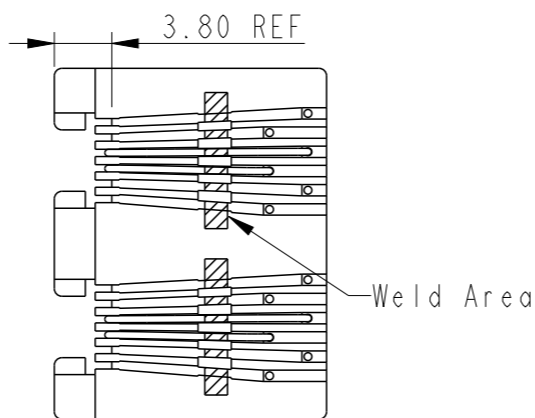
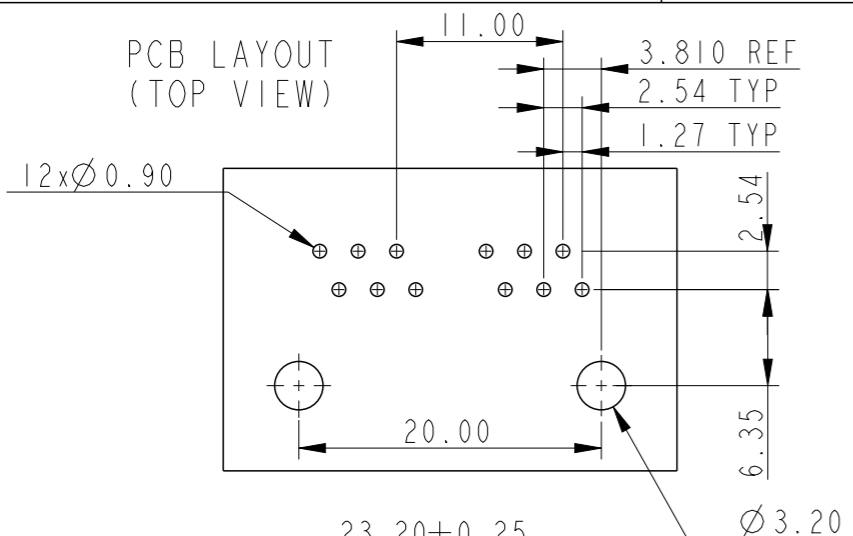

NOTES:

- PLATING DETAILS:
ACTIVE ZONE : GOLD OVER NICKEL (REF. ORDERING INFORMATION)
TERMINATION ZONE: SnPb OVER NICKEL FOR LEADED VERSION
: MATTE TIN OVER NICKEL FOR LEADFREE VERSION.
- CONTACT WIRE SHOULD NOT TO BE EXPOSED IN THE WELD AREA.
WELD FLASH NOT TO EXCEED 0.30 ABOVE DATUM \square AND WELD STRENGTH TO BE CHECKED FOR WITHSTANDING 500g.FORCE MIN.ON INDIVIDUAL CONTACTS
- ALL WIRES MUST BE CONTAINED IN THE SHELF.

PART NO. 10053565-X12 XXX LF

LEAD FREE

CONTACTS LOADED

- | | |
|-----------------------------|--|
| 6 - 0.76 Au SELECTIVE MIN. | BLANK- CTS. LOADED IN ALL POS. |
| 7 - Au FLASH SELECTIVE MIN. | 001 - CTS. LOADED IN A3,A4,B3 & B4 |
| 8 - 1.27 Au SELECTIVE MIN. | 002 - CTS. LOADED IN A2 TO A5 & B2 TO B5 |
| 9 - 0.38 Au SELECTIVE MIN. | |

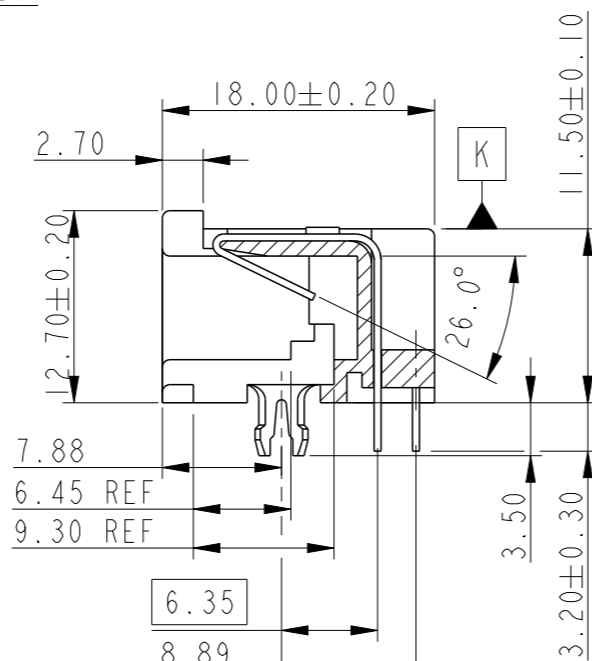
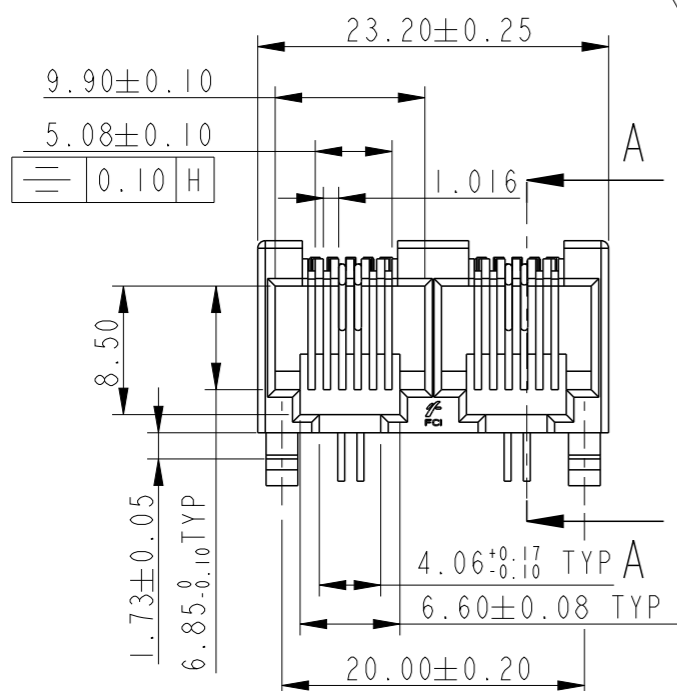

1. LF PRODUCTS MEETS EUROPIEN UNION DIRECTIVES&OTHER COUNTRY REGULATIONS AS DESCRIBED IN GS-22-008.

2. THE HOUSING WILL WITHSTAND 260° PEAK TEMPERATURE FOR 5 SEC IN A WAVE SOLDER APPLICATION WITH A 1.6mm MIN THICK CIRCUIT BOARD. SLIGHT DEFORMATION OF SNAP PEGS MAY OCCUR AT 260-265°C, WHICH WILL NOT AFFECT THE FUNCTION OF THE PRODUCT.

3. LEAD FREE OR ROHS DIRECTIVE LABELLING TO BE PROVIDED AS PER GS-14-920 FOR LEAD FREE VERSION.

MATERIAL

Housing : PBT 30% GF BLACK UL 94-V0
The Housing will withstand exposure to 260-265° for 5 seconds. Use protective adhesive tape (kapton or teflon) or protective metallic device on the areas which are directly exposed to wave soldering as it is used in classical leaded wave soldering
Contact : Ø 0.46 PHOSPHOR BRONZE ROUND WIRE

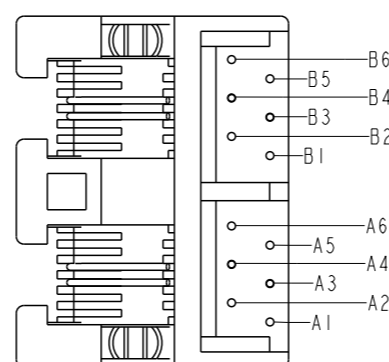
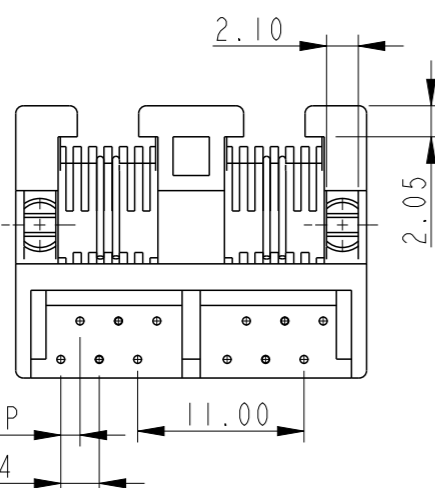

WIRE POSITION

Technical specifications

Insulation Resistance - 500 M Ohms min.
Dielectric Strength - 1000 V rms , 60 Hz.
Contact Resistance - 20 m Ohms to 30 m ohms. max.
Current Rating - 2.0 amp DC
Maximum Total Mating Force - 20 N
Retention Force Between Plug & Jack - 22.5 N min.
Durability - 250 mating cycles

rev	ecn no	dr	date
C	106-0105	HVN	2006-07-06
D	108-0117	NPM	2008-09-17
E	110-0137	NPM	2010-06-23
-	-	-	-
-	-	-	-
-	-	-	-

www.fciconnect.com		surface ✓	tolerance std	projection	mm
		TOLERANCES UNLESS OTHERWISE SPECIFIED		\oplus \ominus	Scale 2:1
Dr	HIRAN V N	2005-03-09	ANGULAR	size A3	
Eng	HIRAN V N	2005-03-09	LINEAR	ECN	
Chr	NEBU PM	2010-06-23	0° ±2°	Product family MODJACKS	Spec ref GS-12-083
Appr	HIRAN V N	2010-06-23	Product family MODJACKS		Spec ref GS-12-083
FCi		6/6 GANG JACK		dwg no 10053565	Rev. E
		2 PORT MODJACK			
		catalog no		sheet 1 of 1	