

J-Series

Hydraulic Magnetic Circuit Breaker

PRODUCT WEBPAGE

request sample, configure part, watch video



Compact Size, Designed for High Power Density Applications

The J-Series is a compact hydraulic-magnetic circuit breaker featuring a 10,000 amp maximum interrupting capacity, making it ideally suited for high power density applications. This low profile circuit breaker offers a variety of actuator styles and terminal options. The J-Series is available in one to three poles with ratings from 1 to 20 amps, up to 240VAC and a max IC of 10,000 amps.

1-3 Poles **1-20** Amps **240** VAC Max **Up to 10,000AIC** Short Circuit Capacity

Typical Applications

- Datacom/Telecom,
- AC Power Supplies,
- AC Power Distribution Units
- Power Dense Motors & Controls
- Marine Applications Requiring High Interrupting Capacity

Tech Specs

Electrical

Dielectric Strength	Meets UL and cULus requirements and can withstand 1500 VAC, 60Hz for one minute between all electrically isolated terminals.
Insulation Resistance	Minimum of 100 Megohms @ 500VDC
Overload	50 operations @ 600% of rated current for AC rated devices.
Inrush Pulse Tolerance	Standard delays 12 times rated current, high inrush delays 25x for ½ cycle @ 60Hz
Interrupt Capacity	See Table A
Resistance, Impedance	(Across circuit breaker terminals)

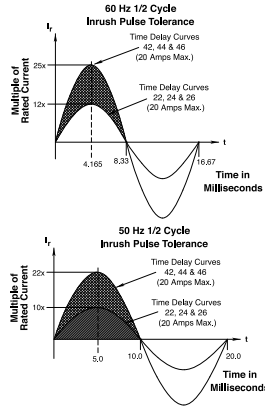
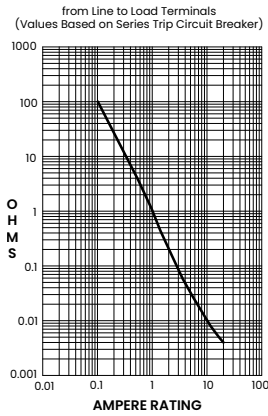

CURRENT (AMPS)	TOLERANCE (%)
0.10 - 5.0	+/- 15
5.1 - 20.0	+/- 25

Mechanical

Endurance	6,000 ON-OFF operations @ 6 per minute; with rated Current and Voltage. 4,000 ON-OFF operations with no load.
Trip Free	All J-Series Circuit Breakers will trip on overload, even when actuator is forcibly held in the ON position.
Trip Indication	The operating actuator moves positively to the OFF position when an overload causes the breaker to trip

Agency Approvals

UL489, cULus CAN/CSA 22.2 No. 5, TUV EN60947-2

Time Delay Specs

To view all hydraulic-magnetic circuit breaker time delay values, please visit www.carlingtech.com/sites/default/files/documents/Carling-HM-CB-Time-Delays.pdf

Tables Table A: Voltage and Current Rating

Electrical Ratings								
Circuit Configuration	Voltage			Current Rating Full Load Amps	Short Circuit Capacity (Amps)			Construction Notes
	Max Rating	Frequency	Phase		UL / cULus	TUV		
				without backup fuse	Ics	Icu		
Series	120/240	50 / 60	1	1.0 - 20.0	10,000	5,000	5,000	2 or 3 Pole
	240						10,000 ¹	

Note:
1 Special Part Number Required. Consult Factory.

Physical

Number of Poles	1 - 3 poles
Termination	Designed for use with straight, fork, flanged fork, and ring terminals.
Termination Torque	See dimensional specs page (Table I) for tightening torque specifications (Line and Load terminals)
Terminal Barrier	Foldable barriers to comply with regulatory standards.
Mounting	Threaded Insert: #6-32 UNC-2B or M3 x 0.5-6 H B ISO (2 per Pole).
Insert Termination Torque	7-9 in-lbs
Actuator	Rocker with or without guard
Internal Circuit Configuration	Series Trip, without auxiliary switch
Materials	Housing - Glass Filled Polyester Rocker - Nylon Line/Load Terminals - Copper Alloy; Bright Acid Tin Plated
Weight	~170 Grams (~5.75 Ounces) per pole
Standard Color	Housing - Black. Rocker - Several (see ordering scheme)

Environmental

Designed and tested in accordance with requirements of specification MIL-PRF-55629 & MIL-STD-202 as follows:

Operation Temperature	-40° C to +85° C
Storage Temperature	-40° C to +85° C
Vibration	Withstands 0.060" excursion from 10-55Hz, and 10G's 55-500Hz, at rated current per Method 204C, Test Condition A. Instantaneous and ultrashort curves tested @ 90% of rated current.
Shock	Withstands 100G's, 6ms saw tooth while carrying rated current per Method 213B, Test Condition "I". Instantaneous and ultra short curves tested @ 90% rated current.
Moisture Resistance	Method 106G, i.e., Ten 24-hour cycles at +25°C to +65°C, 80-98% RH.
Salt Spray	Method 101, Condition A (90-95% RH @ 5% NaCl Solution, 96 hours)
Thermal Shock	Method 107G, Condition A (Five cycles @ -55°C to +25°C to +85°C to 25°C)

Ordering Scheme

Rocker

Sample Part Number

J 1 1 - B 0 - 24-620 - 1 1 B - D G

Selection

1 2 3 4 5 6 7 8 9 10 11 12

1. SERIES

J J-Series Circuit Breaker

2. ACTUATOR

FLAT ROCKER:

Two Color Visi-Rocker

- 1 Indicate OFF, vertical legend
- 2 Indicate OFF, horizontal legend

Single color

- 3 Vertical legend
- 4 Horizontal legend

Push-To-Reset, Visi-Rocker

- 5 Indicate OFF, vertical legend
- 6 Indicate OFF, horizontal legend

Push-To-Reset, Single color

- 7 Vertical legend
- 8 Horizontal legend

CURVED ROCKER:

Two Color Visi-Rocker

- C Indicate ON, vertical legend
- D Indicate ON, horizontal legend
- F Indicate OFF, vertical legend
- G Indicate OFF, horizontal legend

Single color

- J Vertical legend
- K Horizontal legend

3. POLES

- 1 One
- 2 Two
- 3 Three¹

4. CIRCUIT

B Series Trip (Current)

5. AUXILIARY SWITCH

0 without Aux Switch

6. FREQUENCY & TIME DELAY

- 20 50 / 60Hz Instantaneous²
- 21 50 / 60Hz Ultra Short
- 22 50 / 60Hz Short
- 24 50 / 60Hz Medium
- 26 50 / 60Hz Long
- 42 50 / 60Hz Short, Hi-Inrush
- 44 50 / 60Hz Medium, Hi-Inrush
- 46 50 / 60Hz Long, Hi-Inrush

7. CURRENT RATING (AMPERES)

CODE	AMPERES		
410	1.00	435 3.50	480 8.00
512	1.25	440 4.00	485 8.50
415	1.50	445 4.50	490 9.00
517	1.75	450 5.00	495 9.50
420	2.00	455 5.50	610 10.00
522	2.25	460 6.00	710 10.50
425	2.50	465 6.50	611 11.00
527	2.75	470 7.00	711 11.50
430	3.00	475 7.50	612 12.00
			712 12.50
			613 13.00
			614 14.00
			615 15.00
			616 16.00
			617 17.00
			618 18.00
			619 19.00
			620 20.00

8. TERMINAL

- 1 Push-On .250 Tab (Q.C.)
- 2 Screw 8-32 with upturned lugs
- 3 Screw 8-32 (Bus Type)
- 4 Screw 10-32 with upturned lugs
- 5 Screw 10-32 (Bus Type)
- 6 Screw 8-32 with upturned lugs and 30° Bend
- 7 Screw 8-32 (Bus Type) and 30° Bend
- 8 Screw 10-32 with upturned lugs and 30° Bend
- 9 Screw 10-32 (Bus Type) and 30° Bend
- B Screw M5 with upturned lugs
- C Screw M4 with upturned lugs
- F Screw M5 with upturned lugs and 30° Bend
- G Screw M5 (Bus Type) and 30° Bend
- H Screw M5 (Bus Type)
- J Screw M5 Back Connect
- K Screw 10-32 Back Connect
- L Screw 10-32 Back Connect, Alt. Spacing³
- M Screw M5 Back Connect, Alt. Spacing³
- N Screw M4 Back Connect
- P Screw M4 Back Connect, Alt. Spacing³
- R Screw 8-32 Back Connect, Alt. Spacing³
- Y Screw 8-32 Back Connect

9. ACTUATOR COLOR & LEGEND ⁴

Actuator or Visi-Color	Marking:		Marking Color:	
	ON-OFF	Dual	Single Color	Visi-Rocker
White	B	1	Black	White
Black	D	2	White	n/a
Red	G	3	White	Red
Green	J	4	White	Green
Blue	L	5	White	Blue
Yellow	N	6	Black	Yellow
Gray	Q	7	Black	Gray
Orange	S	8	Black	Orange

10. MOUNTING ⁵

Standard Rocker Bezel

- A 6-32 x .195 inches 1 6-32 x .195 inches
- B ISO M3 x 5 mm 2 ISO M3 x 5 mm

Rockerguard (Curved Rocker) / Push-to-Reset (Flat Rocker) Bezel

- C 6-32 x .195 inches 3 6-32 x .195 inches
- D ISO M3 x 5 mm 4 ISO M3 x 5 mm

Recessed Off (Flat Rocker)

- E 6-32 x .195 inches 5 6-32 x .195 inches
- F ISO M3 x 5 mm 6 ISO M3 x 5 mm

11. APPLICATION RATING

- C 120 / 240 VAC⁶
- D 240 VAC

12. AGENCY APPROVAL

- A Without Approvals
- G UL 489 Listed, cULus Listed
- 3 UL 489 Listed, cULus Listed, TUV Certified⁷

Notes:

- 1 3 Pole Units available when 1 of 3 poles is neutral.
- 2 20 Delay available only with no agency approvals.
- 3 Refer to dimensional specifications for alternate back connect terminal spacing dimension.
- 4 TUV Approval requires Dual (I-O, ON-OFF) markings.
- 5 For codes A through F, rocker to be on Pole 1 for multi pole breakers with behind the panel standoff bracket on pole 2. For codes 1 through 6, rocker to be on pole 2 for multipole breakers with behind the panel standoff bracket on Pole 1. For 1 & 3 pole breakers use codes A-F.
- 6 Voltage Rating available with 2 and 3 pole breakers only.
- 7 Special Part Number Required for Tuv Icu 10kaic rating on label. Consult Factory.

[Configure Complete Part Number >](#)

[Browse Standard Parts >](#)

Dimensional Specs Rocker

inches [millimeters]

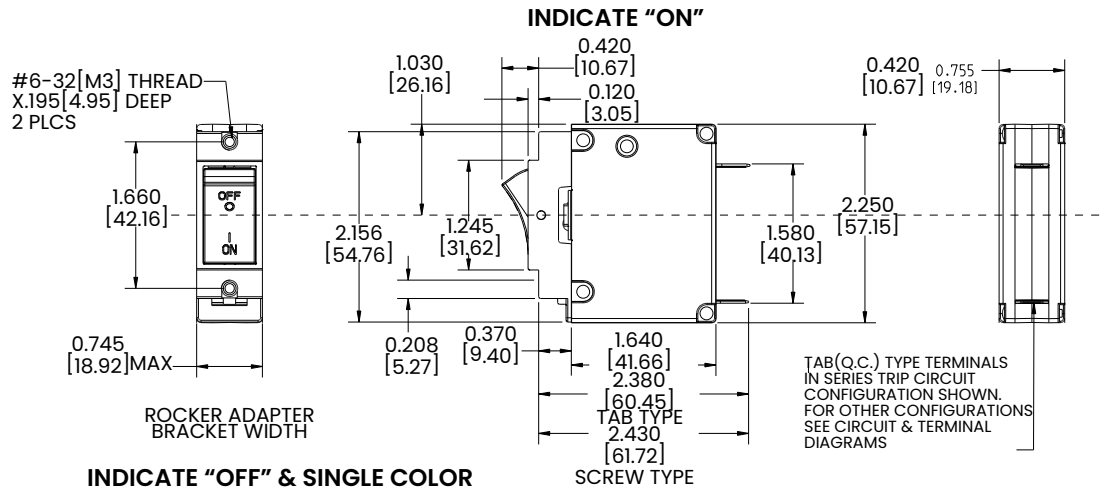

**INDICATE "OFF" & SINGLE COLOR
(INDICATE "OFF" SHOWN)**

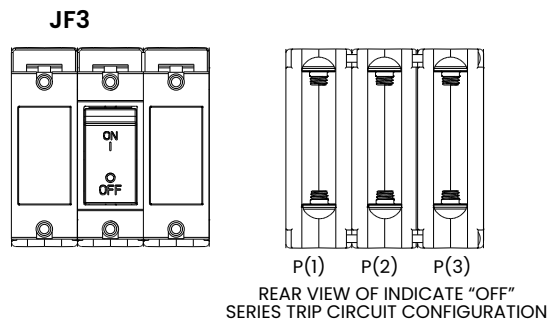
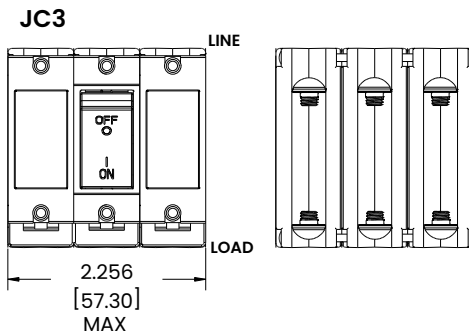
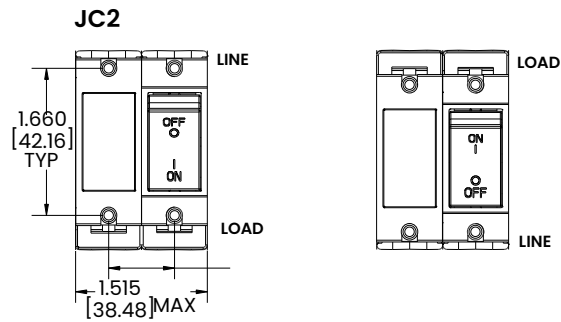
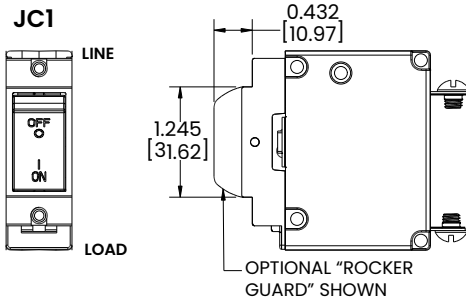
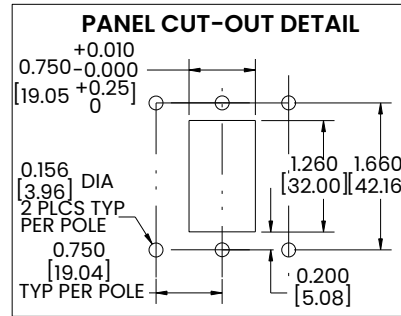
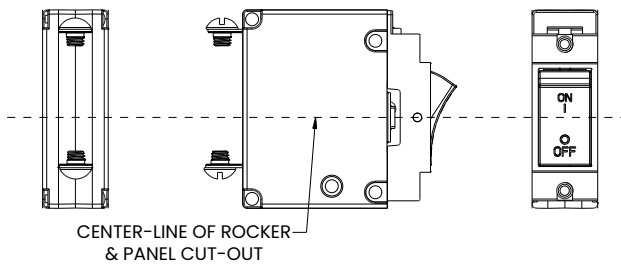

Notes:
1 Tolerance ± 0.020 [51] unless otherwise specified.

Dimensional Specs Rocker

inches [millimeters]

INDICATE "OFF" & SINGLE COLOR (INDICATE "OFF" SHOWN)

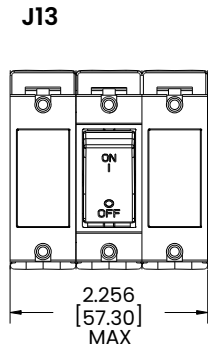
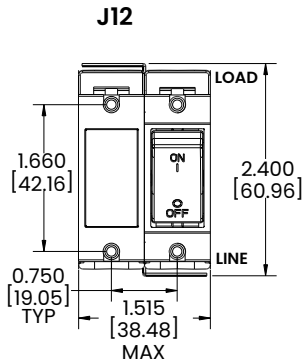
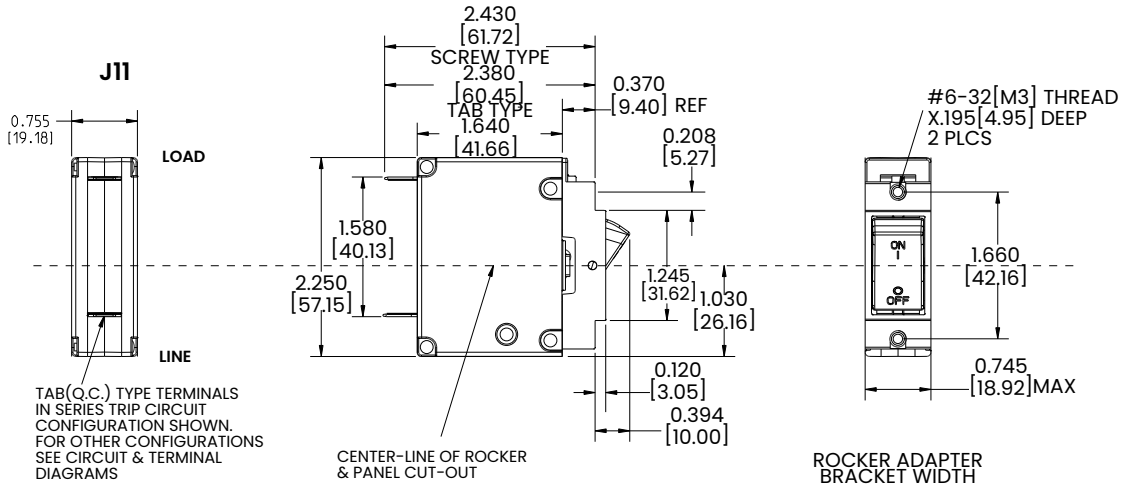

PUSH-TO-RESET ACTUATOR

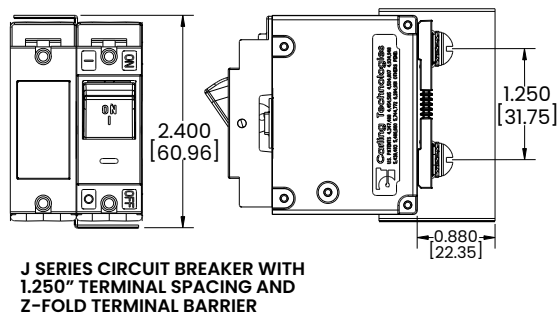
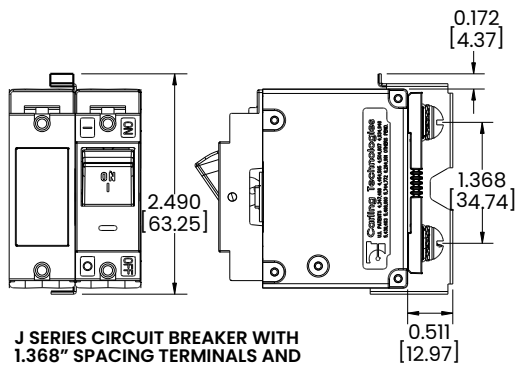
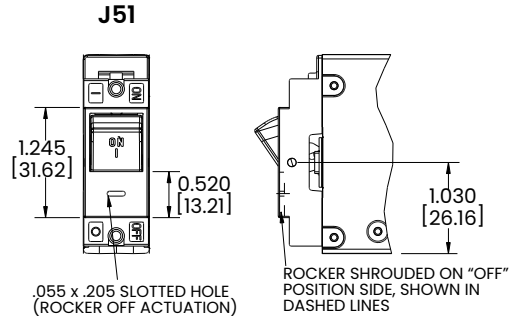

Notes:
1 Tolerance ± 0.020 [0.51] unless otherwise specified.

Dimensional Specs

Rocker

inches [millimeters]

TERMINAL SPACING

SCREW TERMINAL & PUSH-IN Q.C. TAB

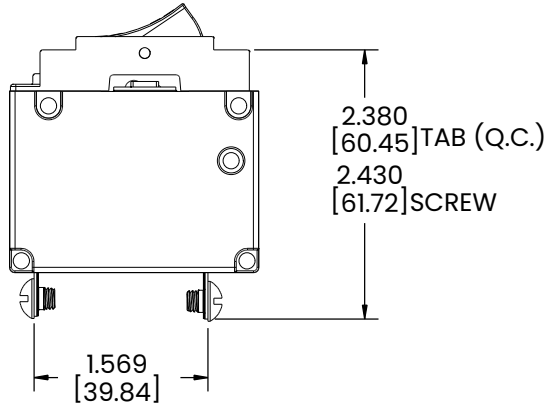

SCREW TERMINAL WITH 30° BEND

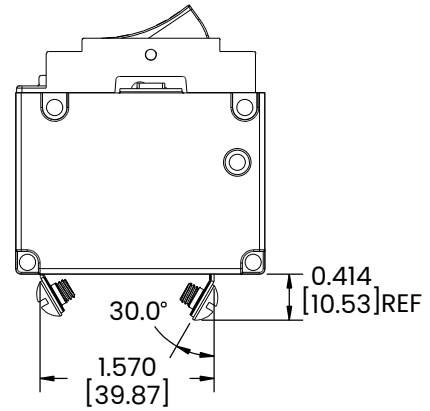

BACK CONNECT SCREW TERMINAL WITH RETAINER

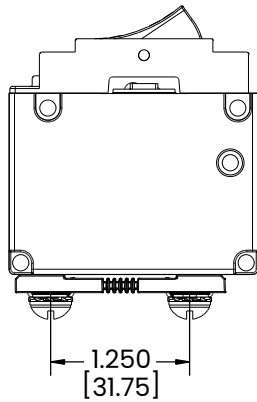

BACK CONNECT SCREW TERMINAL WITH RETAINER-ALTERNATIVE SPACING

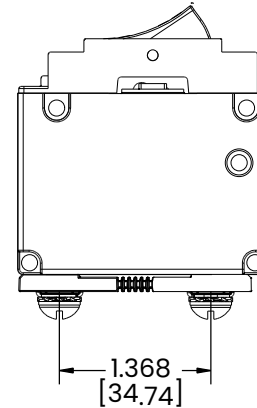

TABLE 1
TIGHTENING TORQUE
SPECIFICATIONS

THREAD SIZE	TORQUE
#6-32 & M3 MOUNTING HARDWARE	7-9 IN-LBS [0.8-1.0 NM]
#8-32 & M4 THREAD TERMINAL SCREW	12-15 IN-LBS [1.4-1.7 NM]
#10-32 & M5 THREAD TERMINAL SCREW	15-20 IN-LBS [1.7-2.3 NM]

Notes:

1 Tolerance ± 0.020 [.51] unless otherwise specified.

Ordering Scheme Handle

Sample Part Number

J A 1 - B 0 - 24 - 620 - 1 2 1 - D 3

Selection 1 2 3 4 5 6 7 8 9 10 11 12

1. SERIES

J J-Series Circuit Breaker

2. ACTUATOR

A Handle, one per pole
B Handle, one per multi-pole unit ¹

3. POLES

1 One **2** Two **3** Three

4. CIRCUIT

B Series Trip (Current)

5. AUXILIARY SWITCH

0 without Aux Switch

6. FREQUENCY & TIME DELAY

21 50 / 60Hz Ultra Short
22 50 / 60Hz Short
24 50 / 60Hz Medium
26 50 / 60Hz Long
42 50 / 60Hz Short, Hi-Inrush
44 50 / 60Hz Medium, Hi-Inrush
46 50 / 60Hz Long, Hi-Inrush

7. CURRENT RATING (AMPERES)

CODE	AMPERES				
410	1.00	435	3.50	480	8.00
512	1.25	440	4.00	485	8.50
415	1.50	445	4.50	490	9.00
517	1.75	450	5.00	495	9.50
420	2.00	455	5.50	610	10.00
522	2.25	460	6.00	710	10.50
425	2.50	465	6.50	611	11.00
527	2.75	470	7.00	711	11.50
430	3.00	475	7.50	612	12.00
				712	12.50
				613	13.00
				614	14.00
				615	15.00
				616	16.00
				617	17.00
				618	18.00
				619	19.00
				620	20.00

Notes:

- Actuator code B (multi-pole only): Handle location as viewed from front of breaker with mounting/barrier code A or B:
 2 pole - right pole 3 pole - center pole
- Refer to dimensional specifications for alternate back connect terminal spacing dimension.
- Single pole only
- ON-OFF markings only available with agency code G. TUV approval requires dual markings
- Codes 1 and 2 are only available for single pole breaker options
 Codes C and D are only available for 2 pole breakers with actuator code B:
 Handle location on left pole as viewed from front of breaker
- Special Part Number Required for Tuv Icu 10kaic rating on label. Consult Factory.

[Configure Complete Part Number >](#)

[Browse Standard Parts >](#)

8. TERMINAL

1 Push-On .250 Tab (Q.C.)
2 Screw 8-32 with upturned lugs
3 Screw 8-32 (Bus Type)
4 Screw 10-32 with upturned lugs
5 Screw 10-32 (Bus Type)
6 Screw 8-32 with upturned lugs and 30° Bend
7 Screw 8-32 (Bus Type) and 30° Bend
8 Screw 10-32 with upturned lugs and 30° Bend
9 Screw 10-32 (Bus Type) and 30° Bend
B Screw M5 with upturned lugs
C Screw M4 with upturned lugs
F Screw M5 with upturned lugs and 30° Bend
G Screw M5 (Bus Type) and 30° Bend
H Screw M5 (Bus Type)
J Screw M5 Back Connect
K Screw 10-32 Back Connect
L Screw 10-32 Back Connect, Alt. Spacing ²
M Screw M5 Back Connect, Alt. Spacing ²
N Screw M4 Back Connect
P Screw M4 Back Connect, Alt. Spacing ²
R Screw 8-32 Back Connect, Alt. Spacing ²
Y Screw 8-32 Back Connect

9. ACTUATOR COLOR & LEGEND ⁴

Handle Color	ON-OFF	Dual	Legend Color
White	B	1	Black
Black	D	2	White
Red	G	3	White
Yellow	N	6	Black
Black (Short Handle) ³	U	9	White

10. MOUNTING / BARRIERS ⁵

	Barriers
1 6-32 x .195 inches threaded inserts	No
A 6-32 x .196 inches threaded inserts	Yes
2 ISO M3 x 5 mm threaded inserts	No
B ISO M3 x 6 mm threaded inserts	Yes
C 6-32 x .195 inches threaded inserts	Yes
D ISO M3 x 6 mm threaded inserts	Yes

11. APPLICATION RATING

C 120 / 240 VAC (2 and 3 pole only)
D 240 VAC (1 and 2 pole only)

12. AGENCY APPROVAL

A Without Approvals
G UL 489 Listed, cULus Listed
3 UL 489 Listed, cULus Listed, TUV Certified ⁶

Dimensional Specs Handle

inches [millimeters]

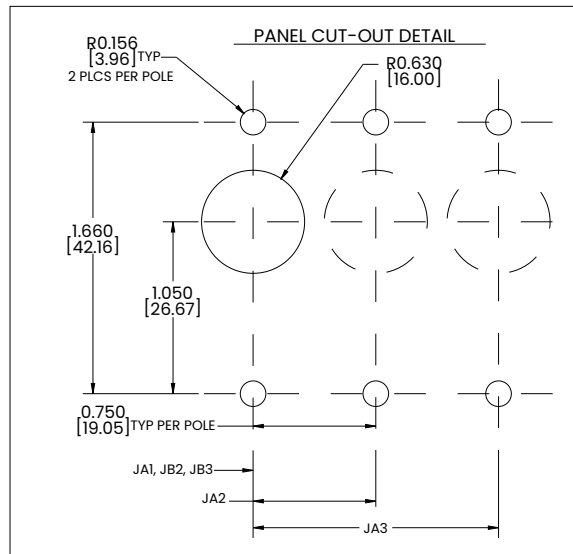
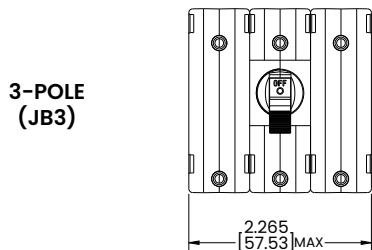
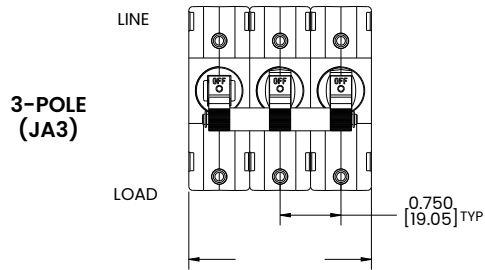
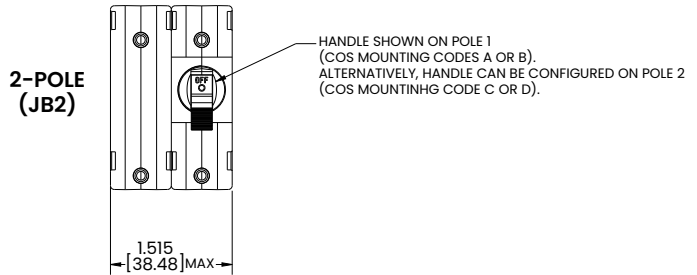
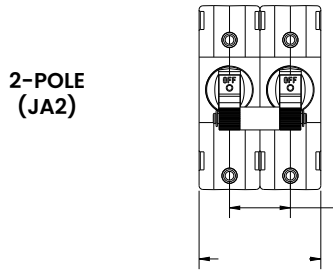
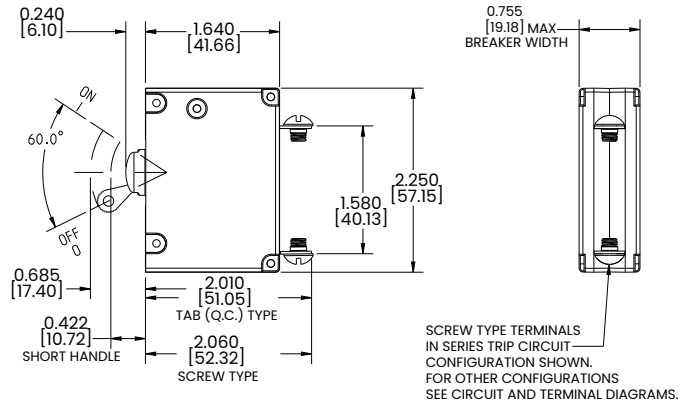
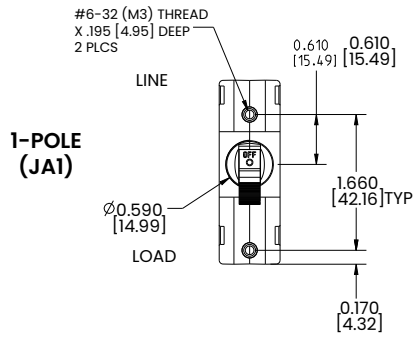

Notes:
1 Tolerance ± 0.020 [51] unless otherwise specified.

Dimensional Specs Handle

inches [millimeters]

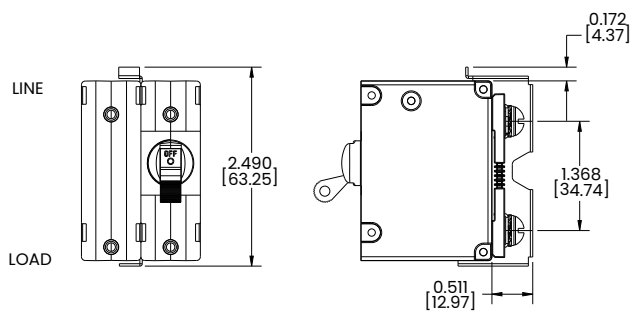
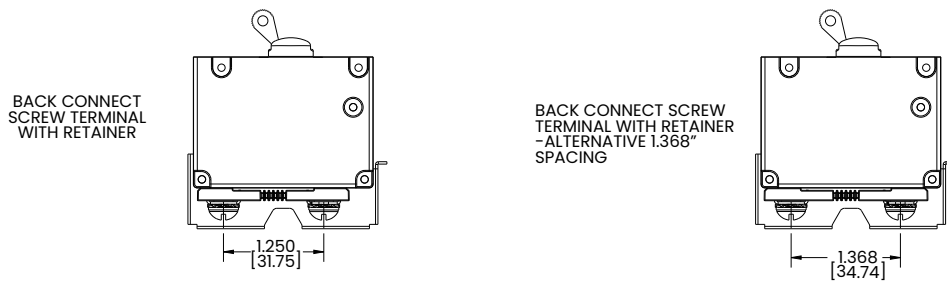

J SERIES CIRCUIT BREAKER WITH 1.368" TERMINAL SPACING AND SCREW TERMINAL BARRIER

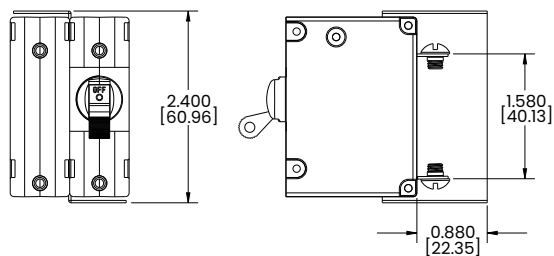

J SERIES CIRCUIT BREAKER WITH 1.250" TERMINAL SPACING AND Z-FOLD TERMINAL BARRIER

Notes:

1 Tolerance ± 0.020 [.51] unless otherwise specified.

Time Delay

AC

Ultrashort

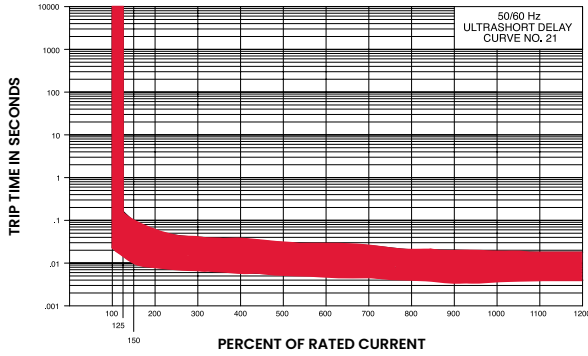

Short

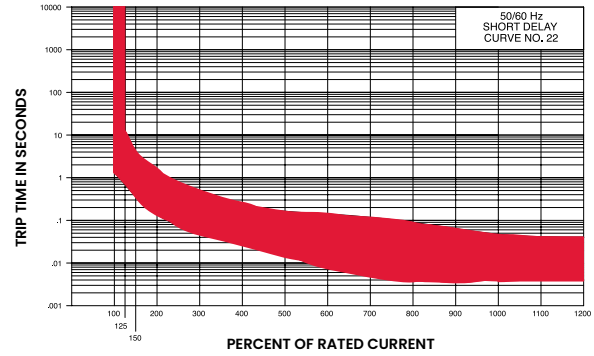

Medium

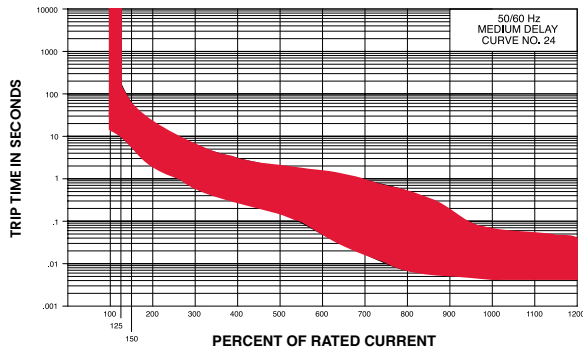

Long

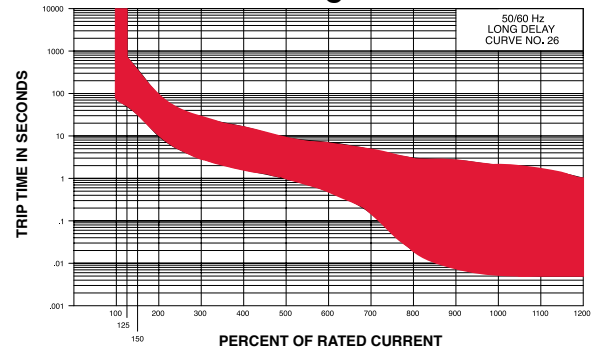

Short

High Inrush AC

Medium

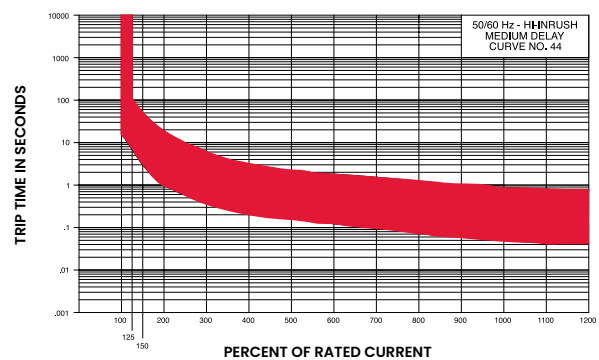
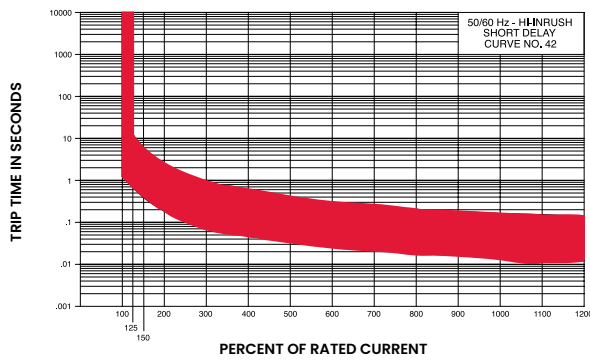

Long

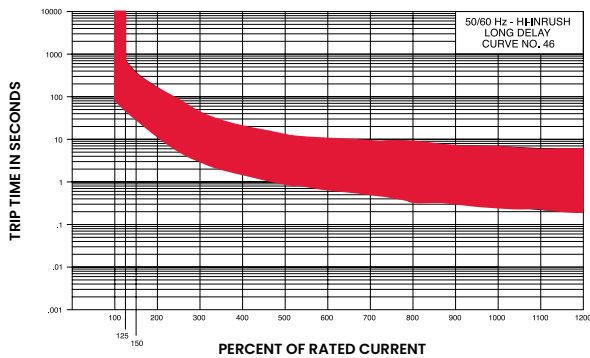

Authorized Sales Representatives and Distributors

Click on a region of the map below to find your local representatives and distributors or visit www.carlingtech.com/findarep.



About Carling

Founded in 1920, Carling Technologies is a leading manufacturer of electrical and electronic switches and assemblies, circuit breakers, electronic controls, power distribution units, and multiplexed power distribution systems. With six ISO9001 and IATF16949 registered manufacturing facilities and technical sales offices worldwide, Carling Technologies Sales, Service and Engineering teams do much more than manufacture electrical components, they engineer powerful solutions! To learn more about Carling please visit www.carlingtech.com/company-profile.

To view all of Carling's environmental, quality, health & safety certifications please visit www.carlingtech.com/environmental-certifications.

© Carling Technologies, Inc.