

# Industrial DC-DC Converters

## 10-15 Watts WD Series

## THE **XP**ERTS IN POWER



- 2:1 Input Range
- 
- Isolated Outputs
- 
- Efficiency to 82%
- 
- 200 kHz Switching Frequency
- 
- Input  $\pi$  Filter
- 
- Fully Regulated Outputs
- 
- Six-sided Shield

## Specification

### Input

- Input Voltage Range**
  - 5 V (4.7-9.0 VDC)
  - 12 V (9-18 VDC)
  - 24 V (18-36 VDC)
  - 48 V (36-72 VDC)

- Input Filter**
  - $\pi$  Network

### Output

- Output Power**
  - 8 Watts for 5 V input version
  - 10 Watts for 12 V input version
  - 15 Watts for 24 & 48 V input versions (optional 10 Watts)

- Voltage Accuracy**
  - $\pm 1\%$  max
- Line Regulation**
  - $\pm 0.2\%$  max
- Load Regulation**
  - $\pm 1\%$  max for a 75% load change
- Ripple & Noise**
  - 100 mV pK-pK max (20 MHz bandwidth)
- Temperature Coefficient**
  - $\pm 0.02\%/^{\circ}\text{C}$  max
- Short Circuit Protection**
  - Continuous

### General

- Switching Frequency**
  - 200 kHz typical
- Efficiency**
  - See Table
- Isolation**
  - 500 V DC input to output (1000 M $\Omega$ /80 pF)
- Dimensions**
  - 2.0" x 1.0" x 0.4"
- Weight**
  - 35 g
- MTBF**
  - 950,000 hours to MIL-STD-217F

### Environmental

- Operating Temperature**
  - -25  $^{\circ}\text{C}$  to +71  $^{\circ}\text{C}$
- Storage Temperature**
  - -40  $^{\circ}\text{C}$  to +100  $^{\circ}\text{C}$

### Safety

- Safety Approvals**
  - UL1950 for LU versions only

OUTPUT VOLTAGE & CURRENT RATINGS							WD
Input Voltage <sup>(1)</sup>	Output Voltage	Output Current	Input Current <sup>(4)</sup>		Efficiency	Model Number <sup>(2,3)</sup>	
			No Load	Full Load			
4.7-9.0 VDC	5.0 VDC	1600 mA	15 mA	2130 mA	75%	WD501	
	12.0 VDC	666 mA	15 mA	2100 mA	76%	WD502	
	15.0 VDC	533 mA	15 mA	2100 mA	76%	WD503	
	±12.0 VDC	±333 mA	15 mA	2100 mA	76%	WD504	
	±15.0 VDC	±266 mA	15 mA	2100 mA	76%	WD505	
9-18 VDC	±5.0 VDC	±800 mA	15 mA	2100 mA	76%	WD506	
	3.3 VDC	3000 mA	20 mA	1056 mA	76%	WD100	
	5.0 VDC	2000 mA	30 mA	1100 mA	76%	WD101	
	12.0 VDC	830 mA	30 mA	1065 mA	78%	WD102	
	15.0 VDC	666 mA	30 mA	1065 mA	78%	WD103	
	±12.0 VDC	±415 mA	40 mA	1065 mA	78%	WD104	
	±15.0 VDC	±333 mA	40 mA	1065 mA	78%	WD105	
18-36 VDC	±5.0 VDC	±1000 mA	40 mA	1065 mA	78%	WD106	
	3.3 VDC	3000 mA	20 mA	543 mA	76%	WD200	
	5.0 VDC	3000 mA	20 mA	800 mA	78%	WD201	
	12.0 VDC	1250 mA	20 mA	780 mA	80%	WD202	
	15.0 VDC	1000 mA	20 mA	780 mA	80%	WD203	
	±12.0 VDC	±625 mA	30 mA	780 mA	80%	WD204	
	±15.0 VDC	±500 mA	30 mA	780 mA	80%	WD205	
36-72 VDC	±5.0 VDC	±1500 mA	30 mA	780 mA	80%	WD206	
	3.3 VDC	3000 mA	15 mA	272 mA	76%	WD300	
	5.0 VDC	3000 mA	10 mA	390 mA	80%	WD301	
	12.0 VDC	1250 mA	10 mA	380 mA	82%	WD302	
	15.0 VDC	1000 mA	10 mA	380 mA	82%	WD303	
	±12.0 VDC	±625 mA	15 mA	380 mA	82%	WD304	
	±15.0 VDC	±500 mA	15 mA	380 mA	82%	WD305	
	±5.0 VDC	±1500 mA	15 mA	380 mA	82%	WD306	

**Notes**

- Nominal input voltage 5, 12, 24 or 48 VDC.
- For optional 10 W version: Add Suffix 'L' to WD2xx and WD3xx, except models WD200 and WD300.
- UL1950 approvals available on 10 W models only. Add suffix 'LU' to models WD1xx, WD2xx or WD3xx, not available on WD5xx series.
- Input current is at nominal input voltage.

**Mechanical Details**

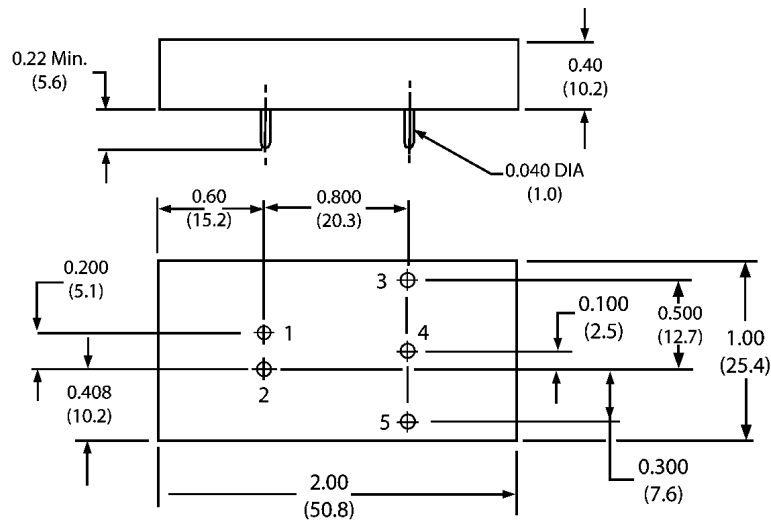

Dimensions in inches (mm)

PIN CONNECTIONS		
Pin	Single Output	Dual Output
1	+ Input	+ Input
2	- Input	-Input
3	+Output	+Output
4	No Pin	Common
5	-Output	-Output