



MAKER WORKS TECHNOLOGY INC

Technical support: support@makeblock.cc

www.makeblock.cc



:@Makeblock



: @Makeblock



: +Makeblock



Starter Robot Kit **Bluetooth Version**

Robot Tank

Three-Wheeled Robot Car

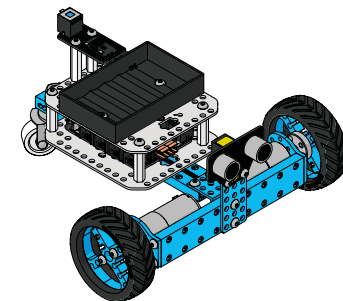
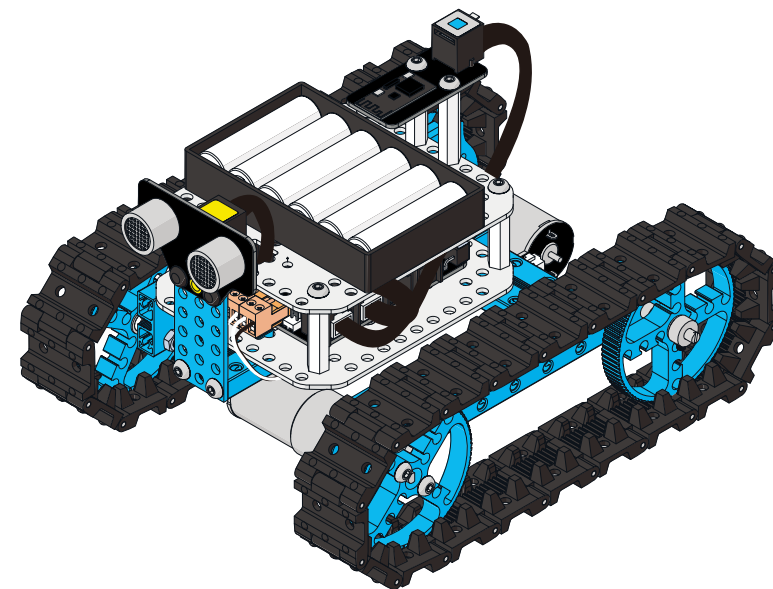

Quick Guide

Warning: Keep this kit out of the reach of small children or animals. Small parts may cause choking or serious injury if swallowed.

Makeblock Starter Robot Kit contains mechanical parts and electronic modules for you to start exploring the robot world which can be used to build a robot tank or a three-wheel robot car. It is also a great tool to learn mBlock and Scratch programming.



Please visit

<http://learn.makeblock.cc/starter-robot-kit/>

to view the build and programming guide.



Parts List



Check all components in parts list, please contact Makeblock or the distributor if any component lacked.

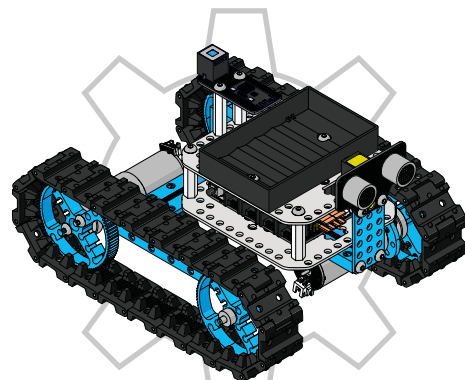

Build the Robot Tank



Follow our manual to build the Robot Tank.

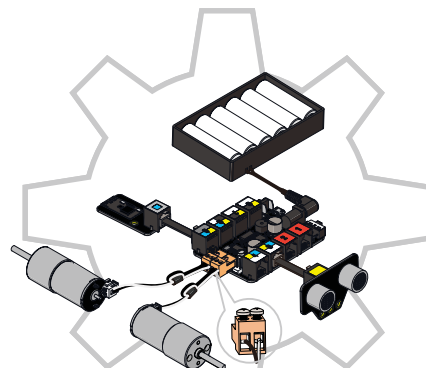

Wiring



Do wiring. Install batteries for your robot .

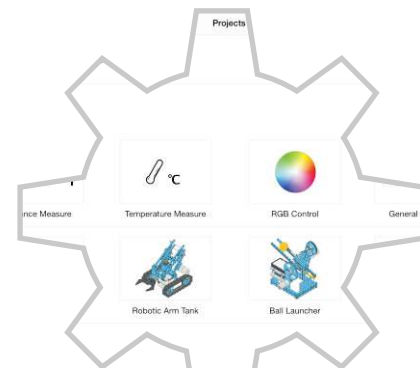

Control with App



Turn on the power of your robot, control your robot with App .
Now it's time to play your robot!

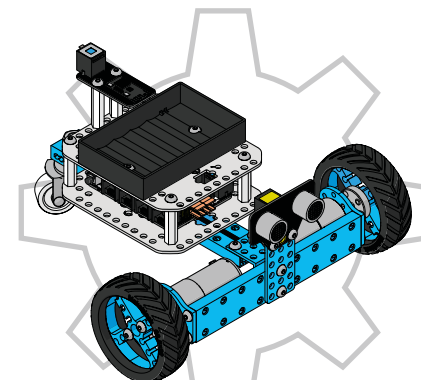

Build three-wheeled Robot Car



Try another style:
Follow our manual to build the Three-wheeled Robot Car.



Programming Guide--Further exploration



Advanced player can re-program to the robot by mBlock or Arduino to explore the wonderful robotic world.

Parts List

Pictures for reference only

1× Beam 0824-96



1× Beam 0824-128

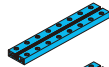

2× Beam 0824-144



1× Bracket 3×3



1× Plate 3×6



1× Bracket P3



1× Caster Wheel



1× Nut M8



2× DC Motor-25 Bracket



2× Shaft Connector 4mm



4× Timing Pulley 90T



2× Tire 68.5×22mm



36× Track



36× Track Axle



2× Threaded Shaft 4×39mm



2× Shaft Collar 4mm



4× Flange Bearing 4×8×3mm



1× Hex Screwdriver



1× Cross Screwdriver



1× Hex Allen Key 2.5mm



2× Hex Allen Key 1.5mm



1× Wrench



20× Screw M4×8



12× Screw M4×14



4× Screw M4×22



12× Nut M4



4× Headless Set Screw M3×5



4× Screw M3×8



6× Plastic Ring 4×7×2mm



6× Nylon Stud M4×30



2× BaseBracket



1× Battery Holder for (6) AA



2× DC Motor-25



2× Terminal Block



2× Motor Cable



2× Ferrite Ring



1× Makeblock Orion



1× Me Ultrasonic Sensor



1× Me Bluetooth Module



1× Micro USB cable



1× 6P6C RJ25 Cable-20cm



1× 6P6C RJ25 Cable-35cm



Tool Tips

Hex Screwdriver



Hex Allen Key 2.5mm



Screw M4×8



Screw M4×14



Screw M4×22



Cross Screwdriver



Screw M3×8



Terminal Block

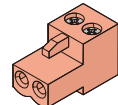

Hex Allen Key 1.5mm

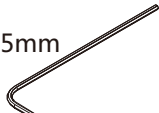

Headless Set Screw M3×5



Wrench

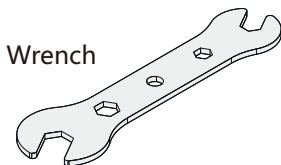

Nut M4



Build the Robot Tank

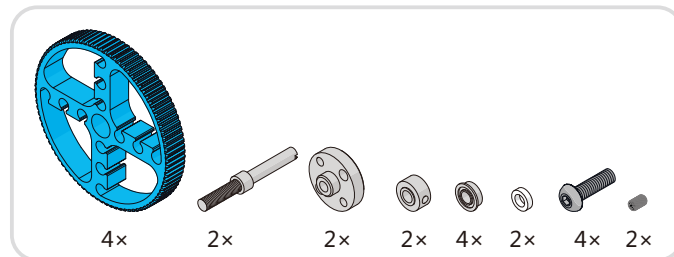
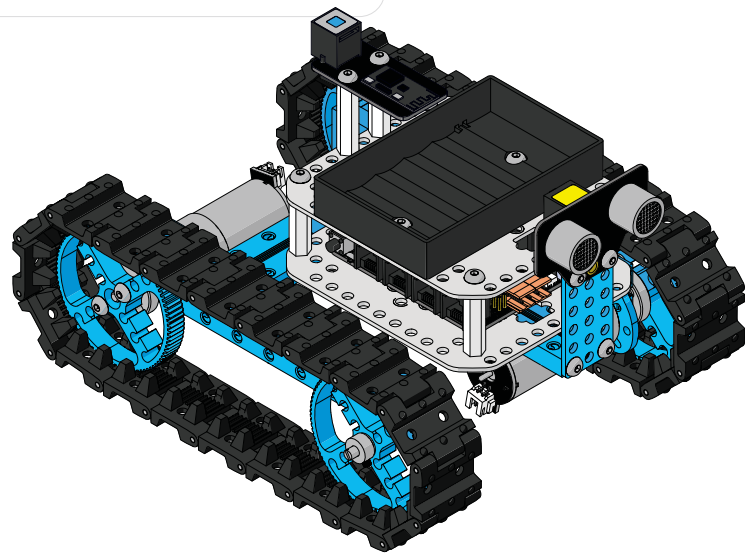
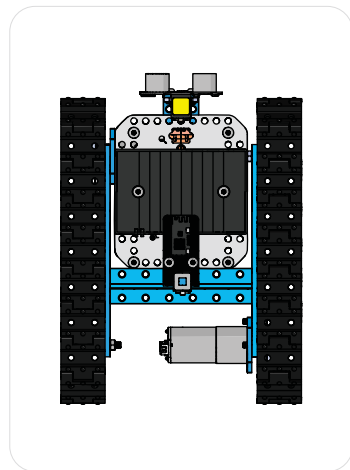
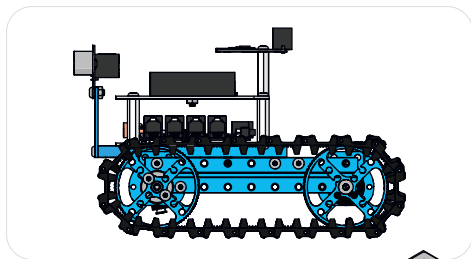
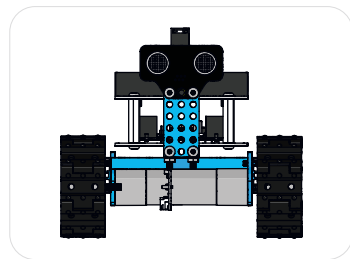

1

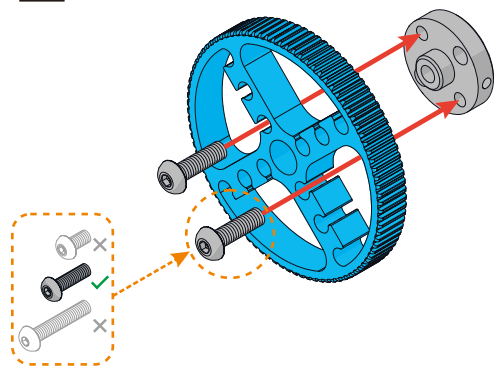

2x Screw M4x14

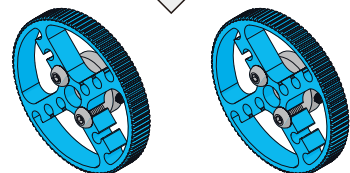

2

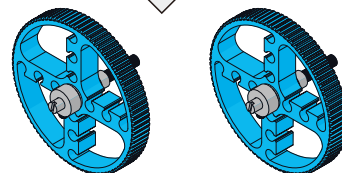
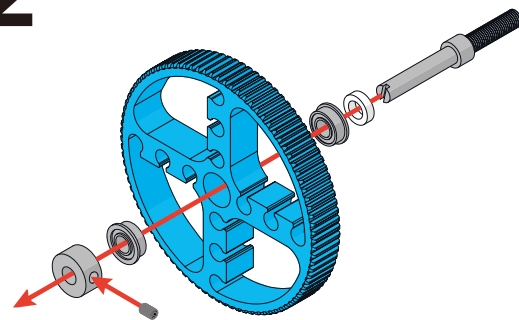

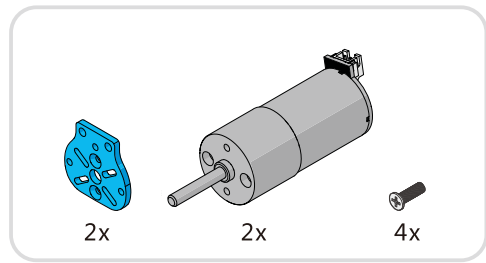

3

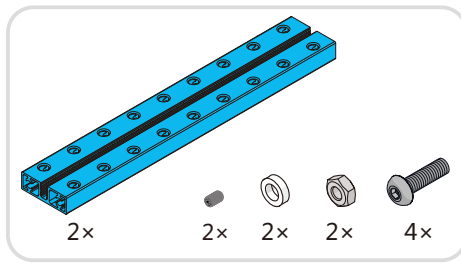
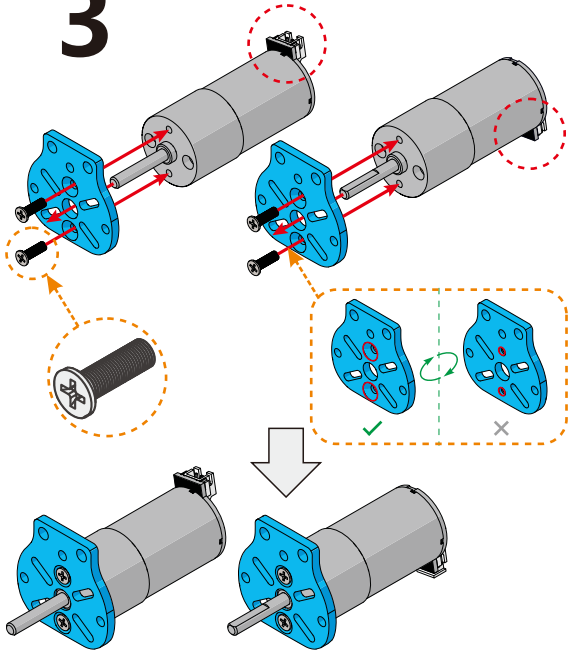

Tips: Identify the right mechanical parts from similar ones with different hole quantity included.

4

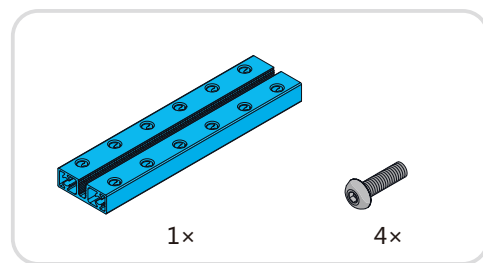
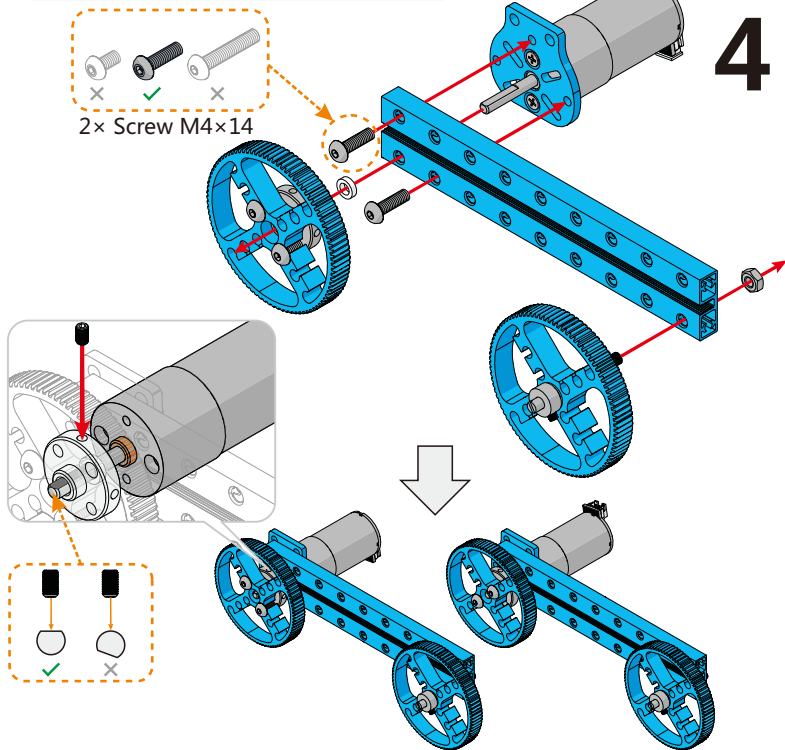

5

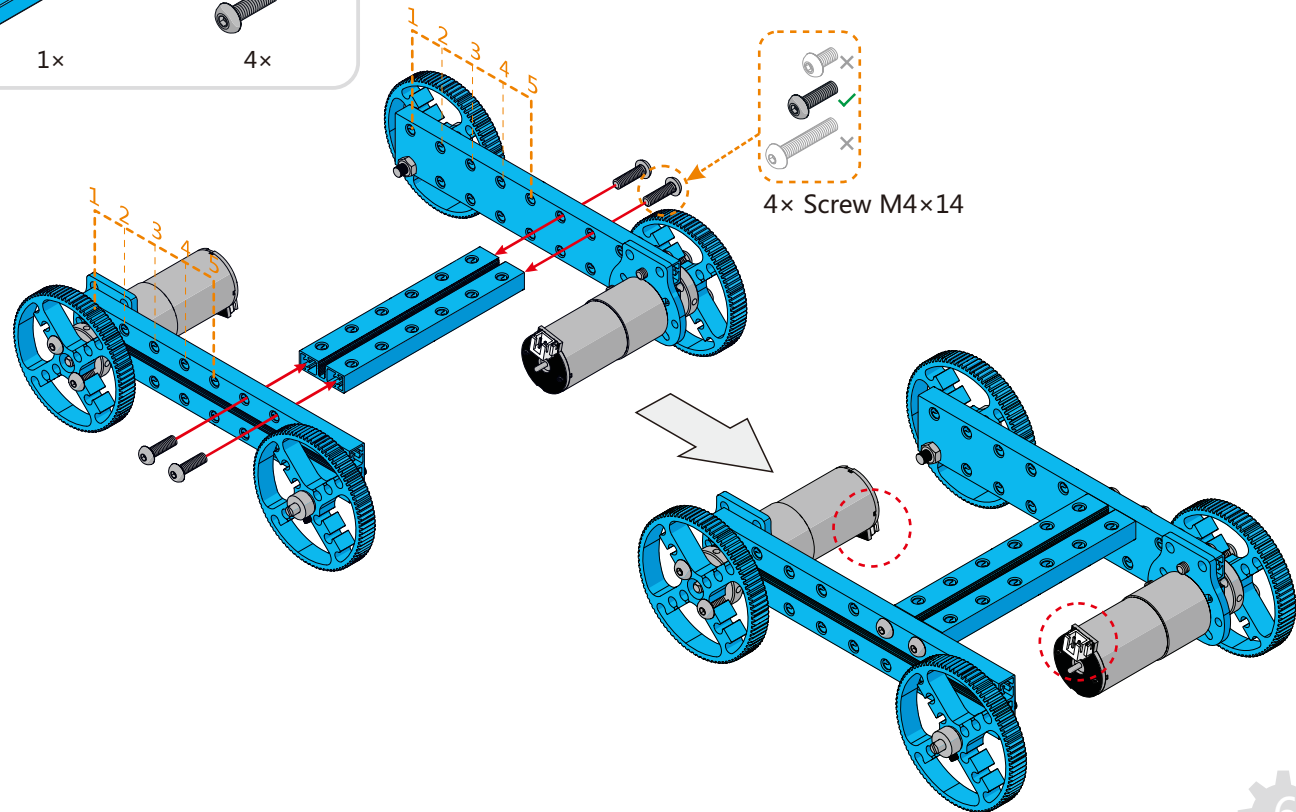

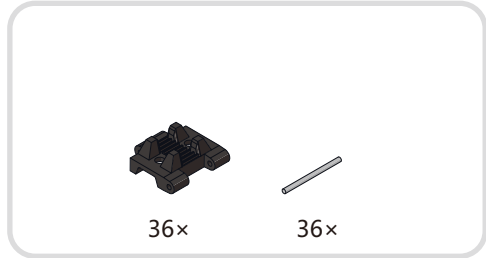

6

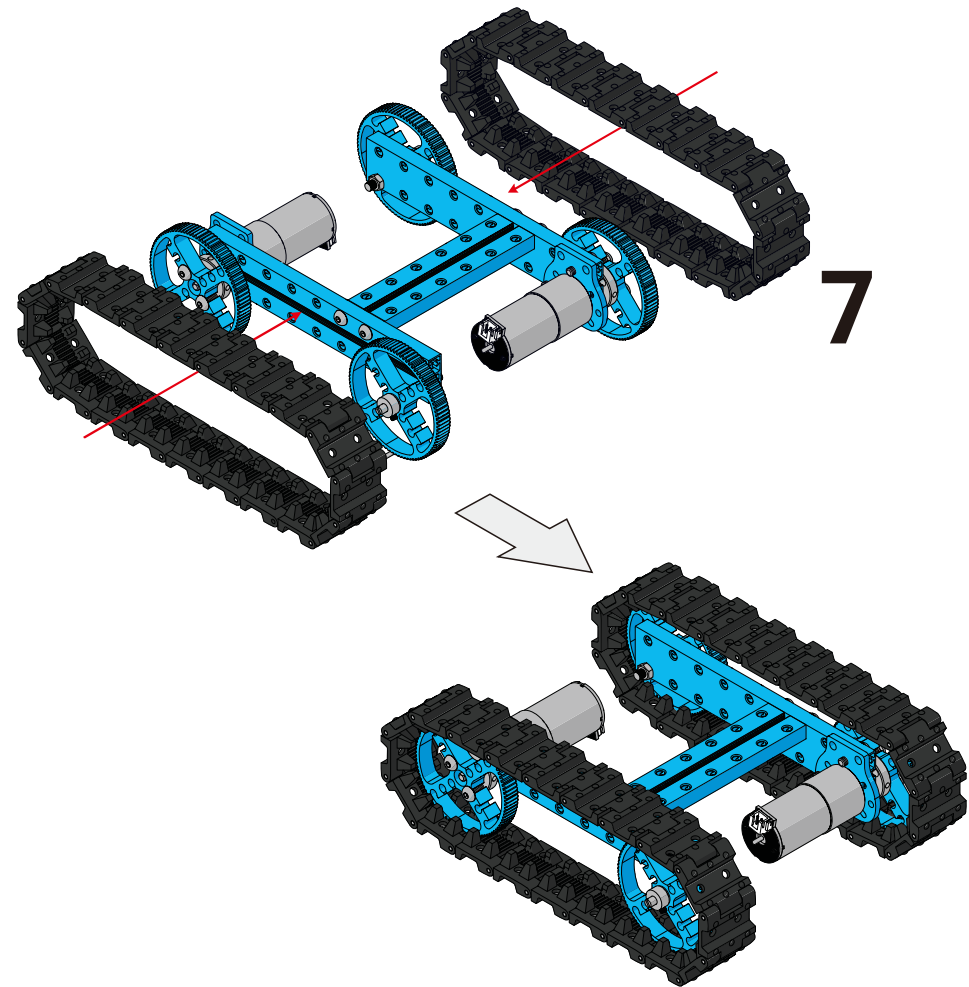
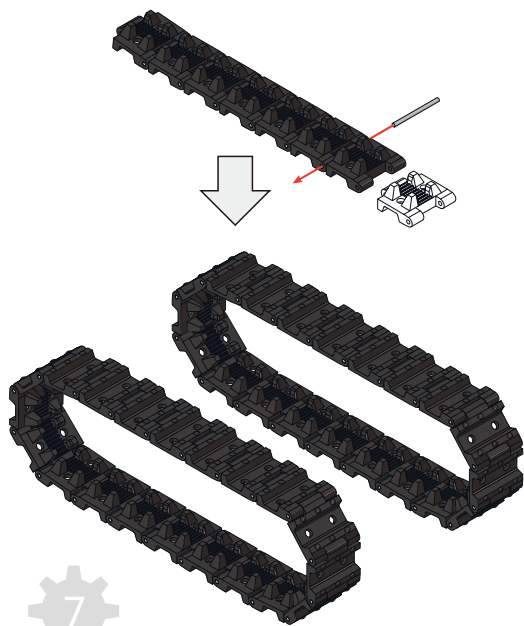

7

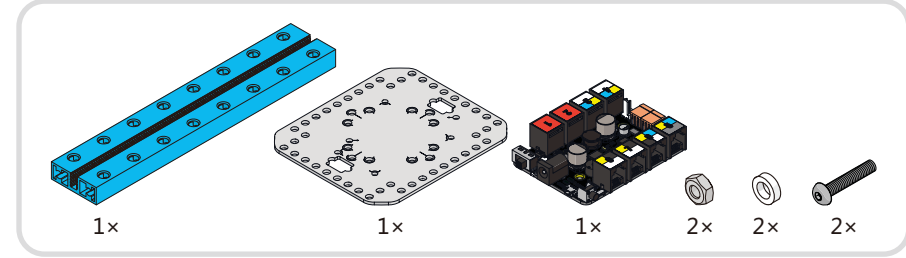

8

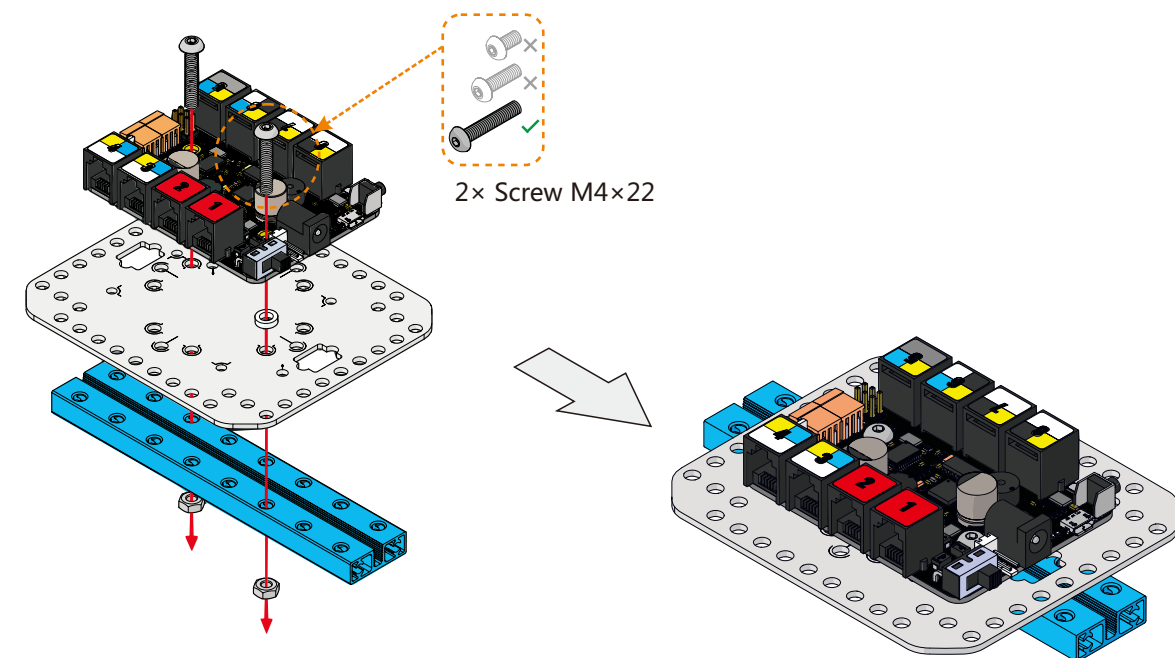

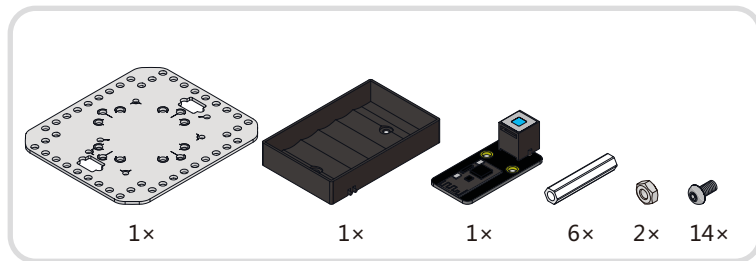

9

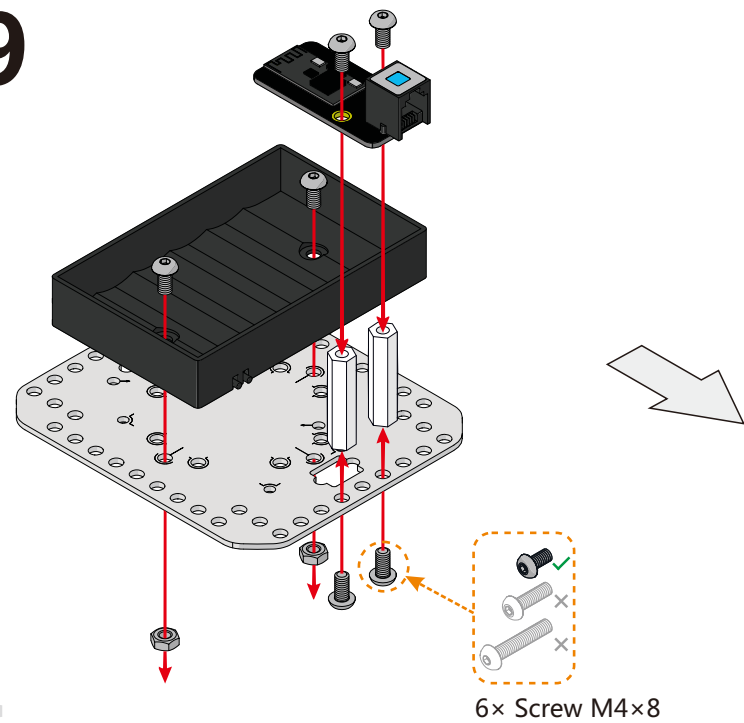

10

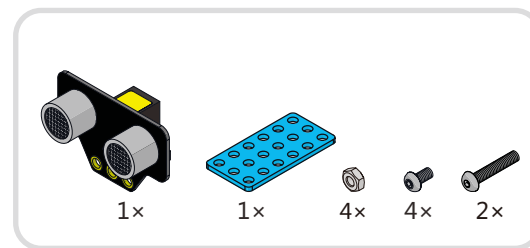
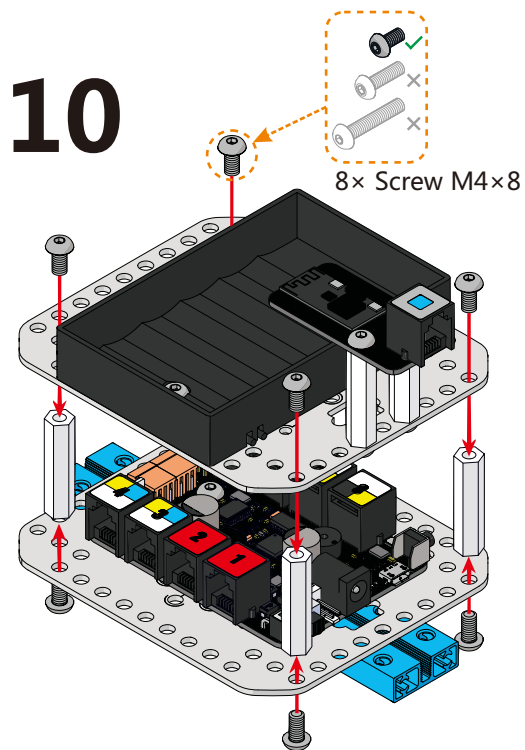

11

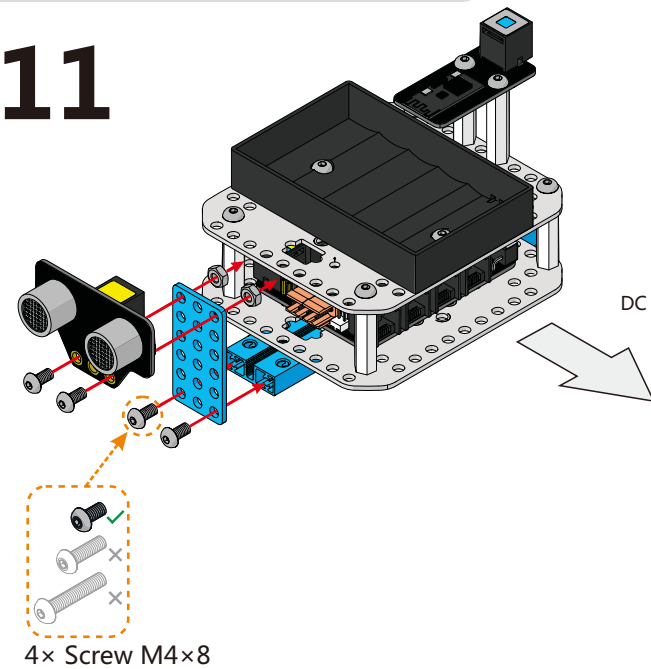

2x Screw M4x22

DC Motor-25(M1)

DC Motor-25(M2)

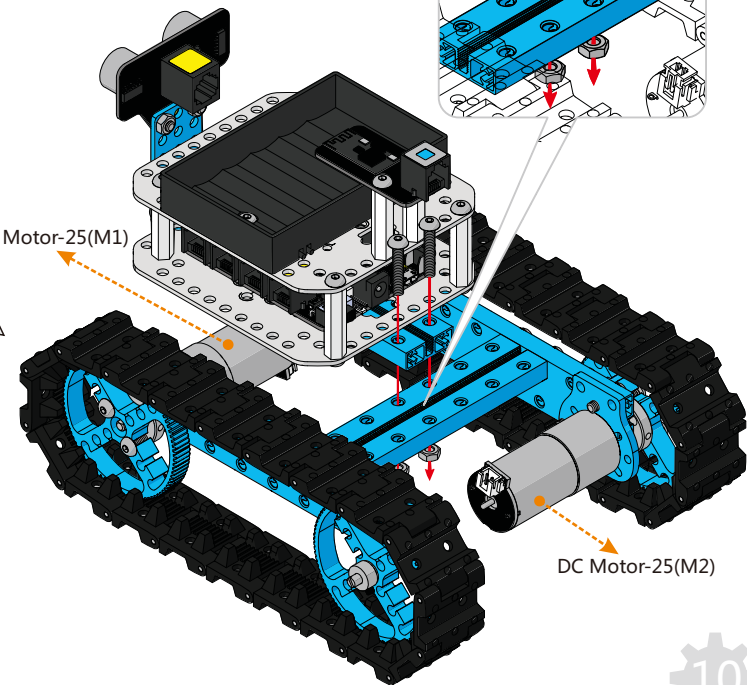

Wiring

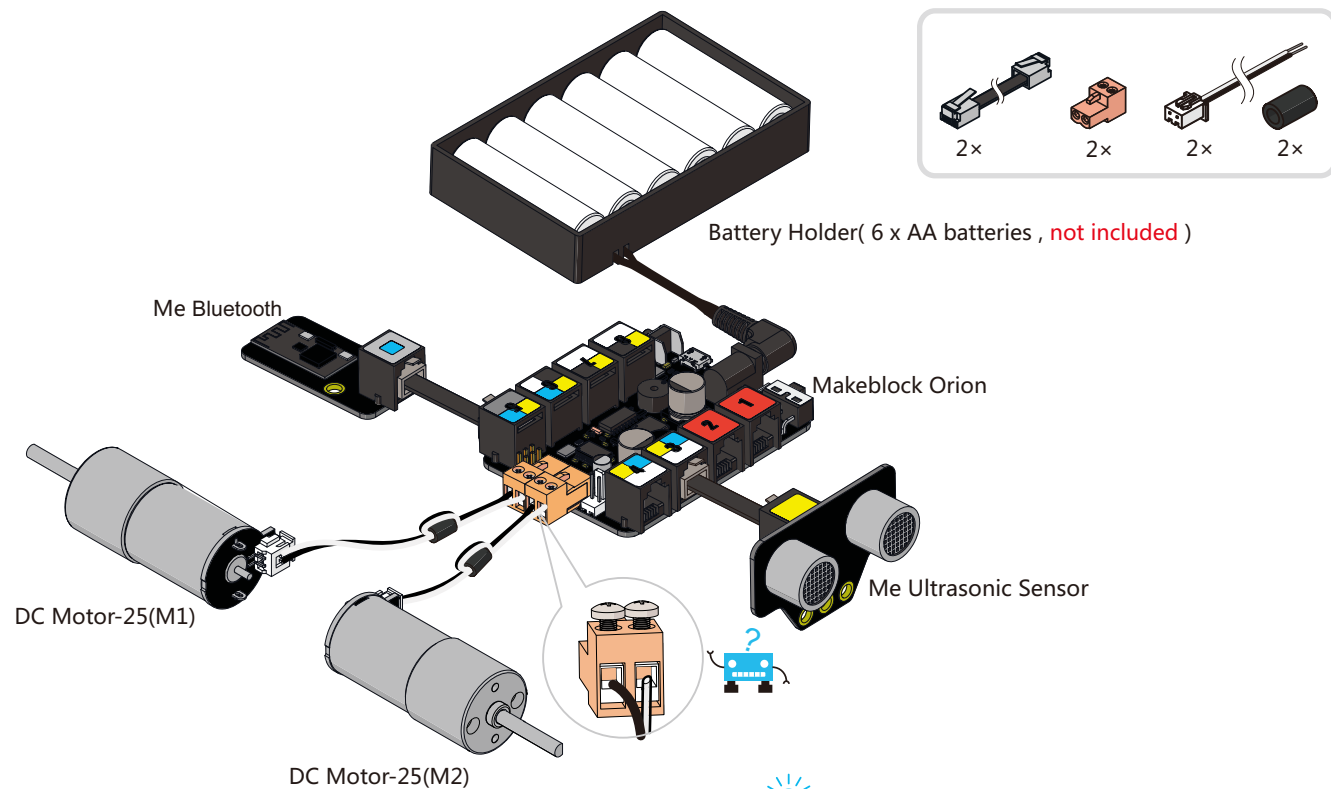

 You may need to switch the order of two wires to correct the rotation direction.

Control with App

- 1、 Download and install Makeblock HD app **by either way below**.
 - A. Download Makeblock app at <http://app.makeblock.cc/>
 - B. Scan QR code below to download Makeblock app.(Figure 1)
- 2、 Check wiring, make sure everything is correct, and then turn on the power of your robot.
- 3、 Turn on the Bluetooth of your smart device.
- 4、 Run Makeblock app, select your robot from Examples.(Figure 2)
- 5、 Put your smart device close to robot, press the play button to find Bluetooth device,and then connect the robot to your smart device.(Figure 3)
- 6、 Control your robot with the direction button.

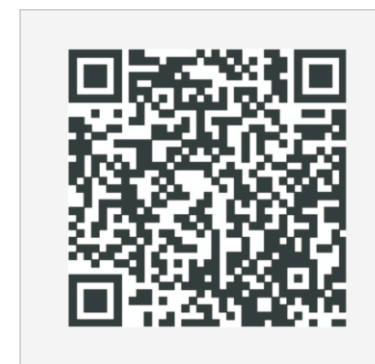

Figure 1

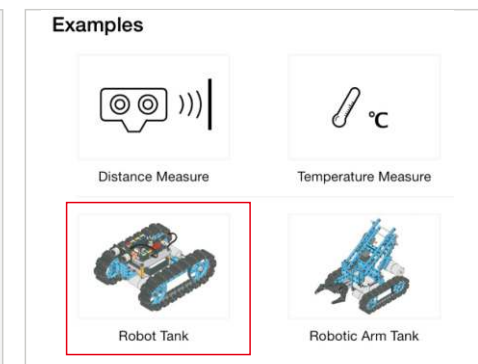

Figure 2

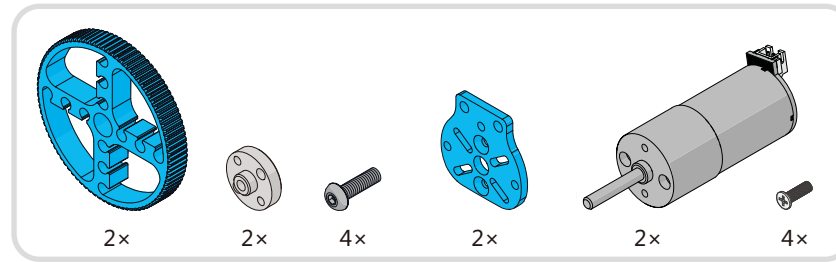
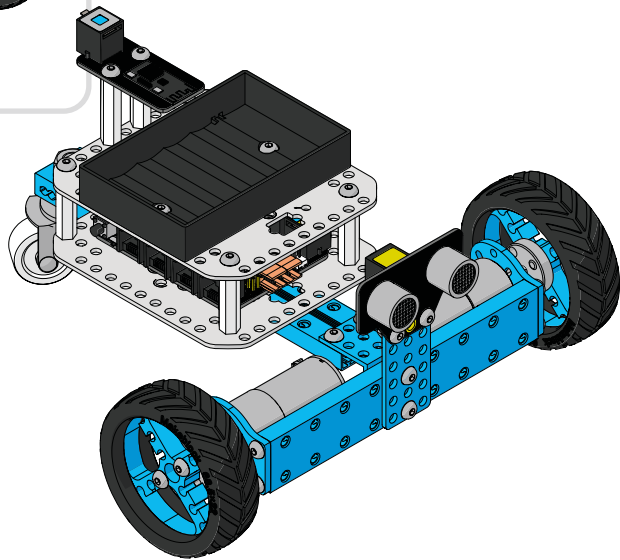
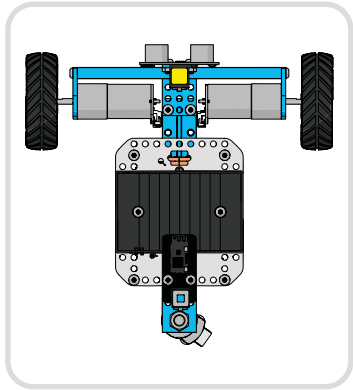
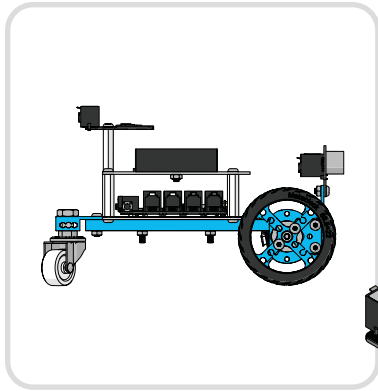
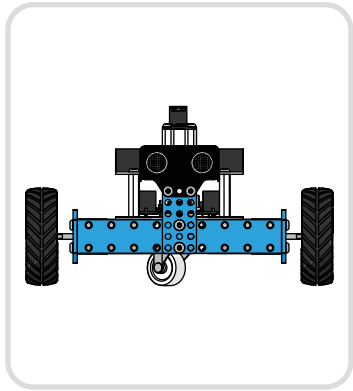

Figure 3

Now it's time to play your robot!



Build three-wheeled Robot Car



1

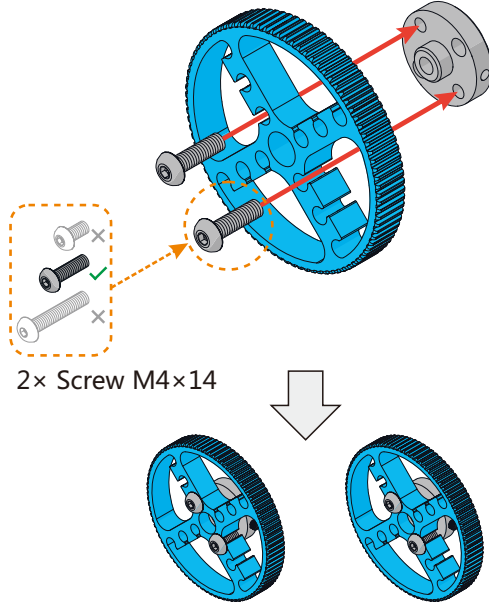

2

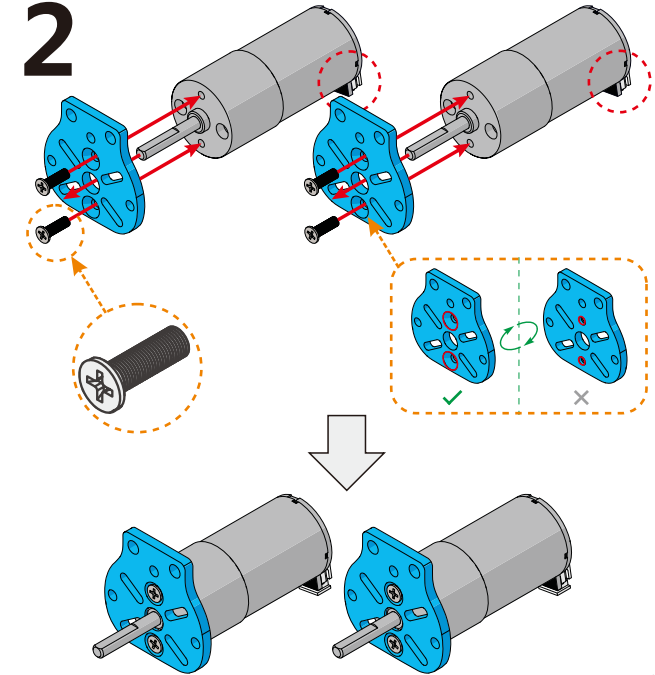

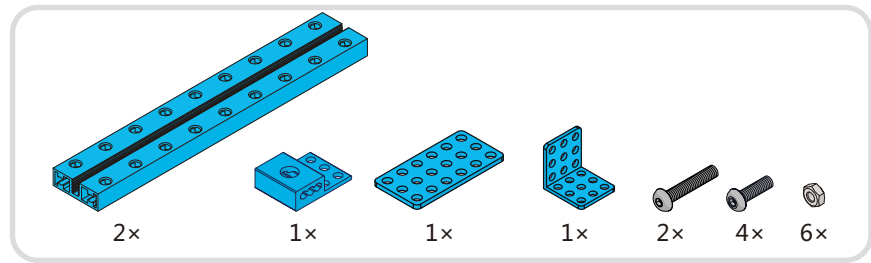

3

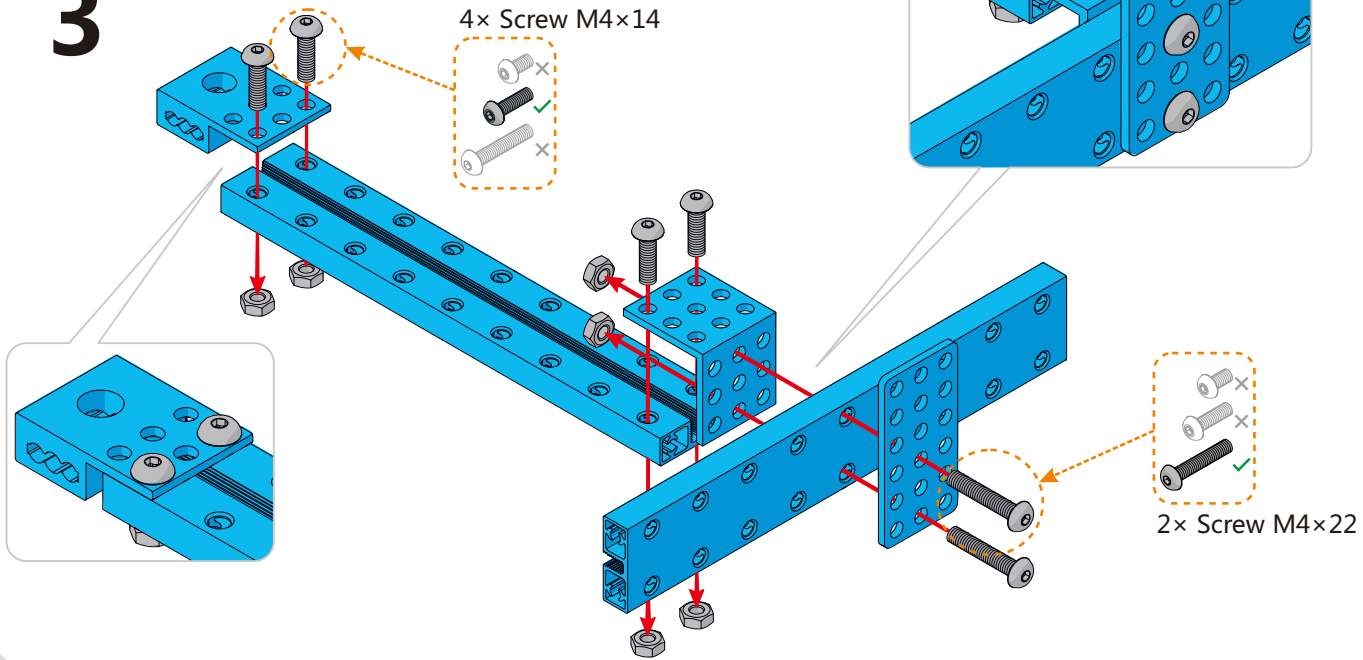

4

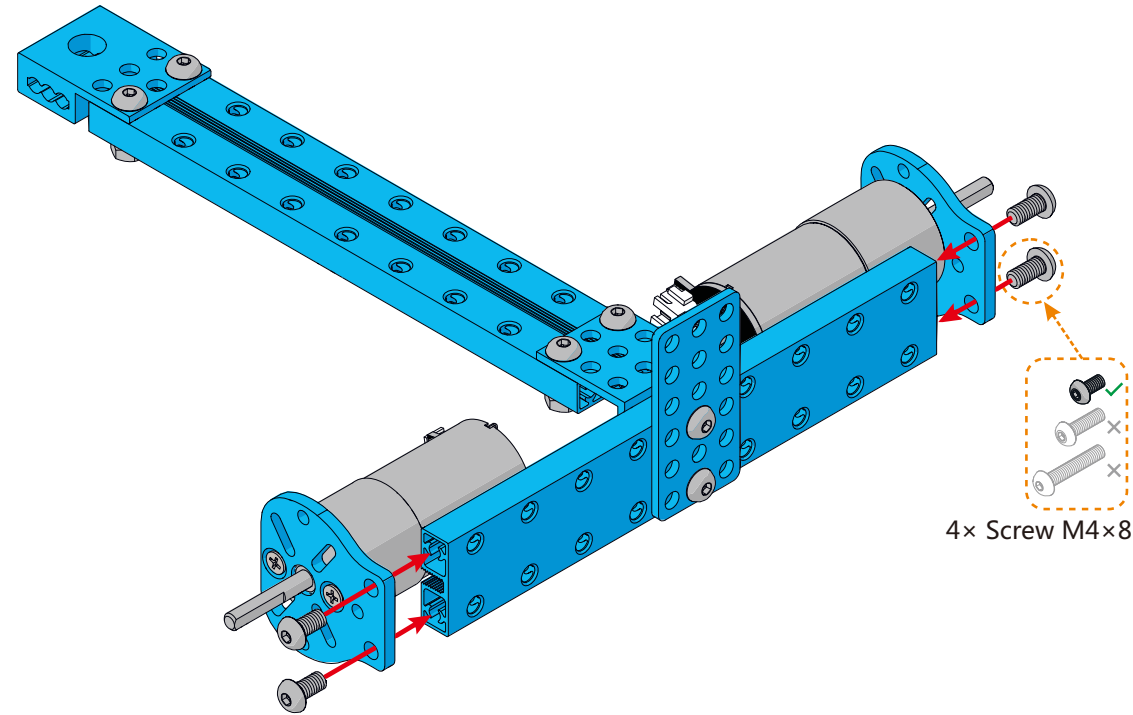

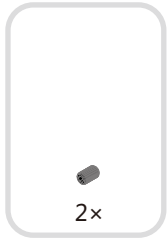

5

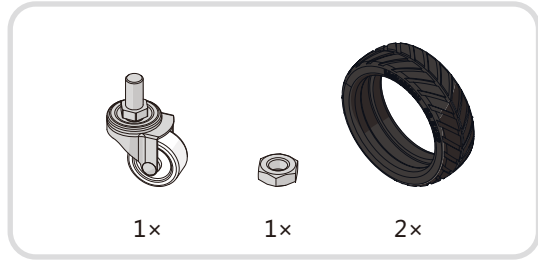
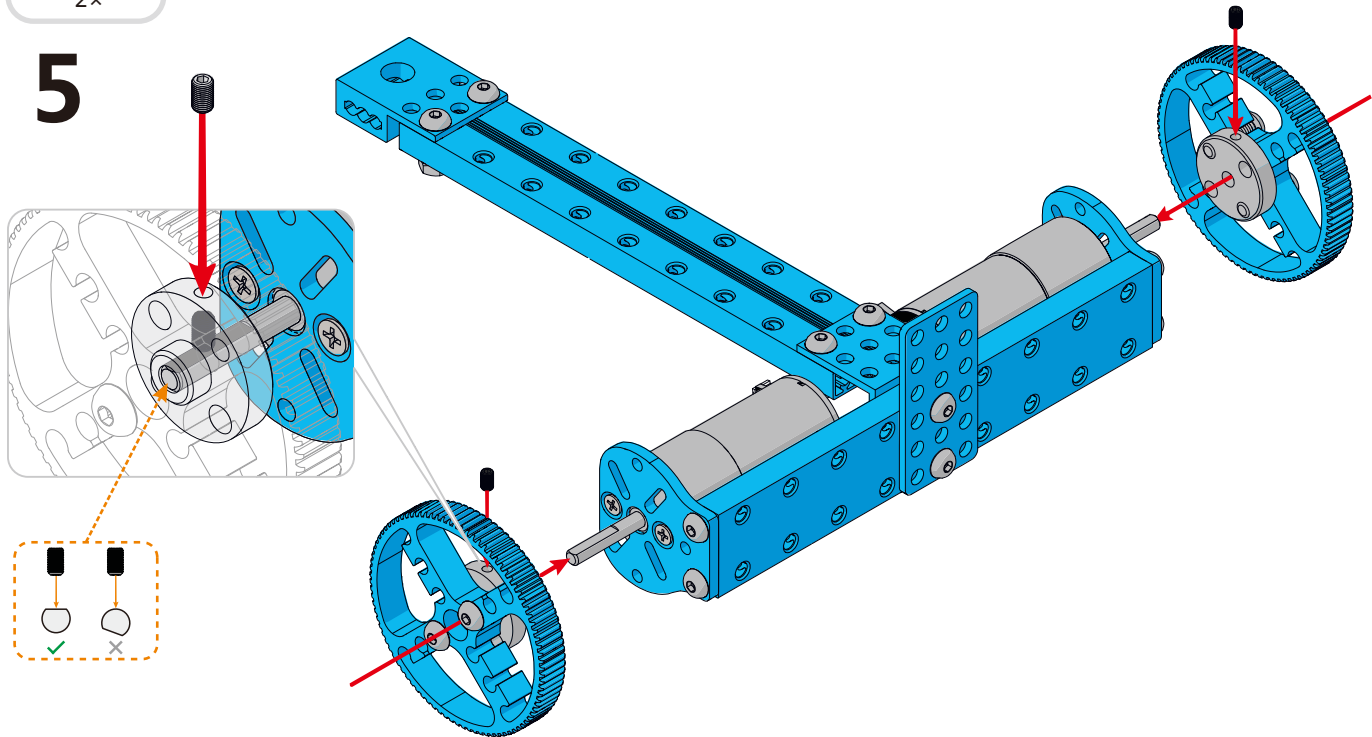

6

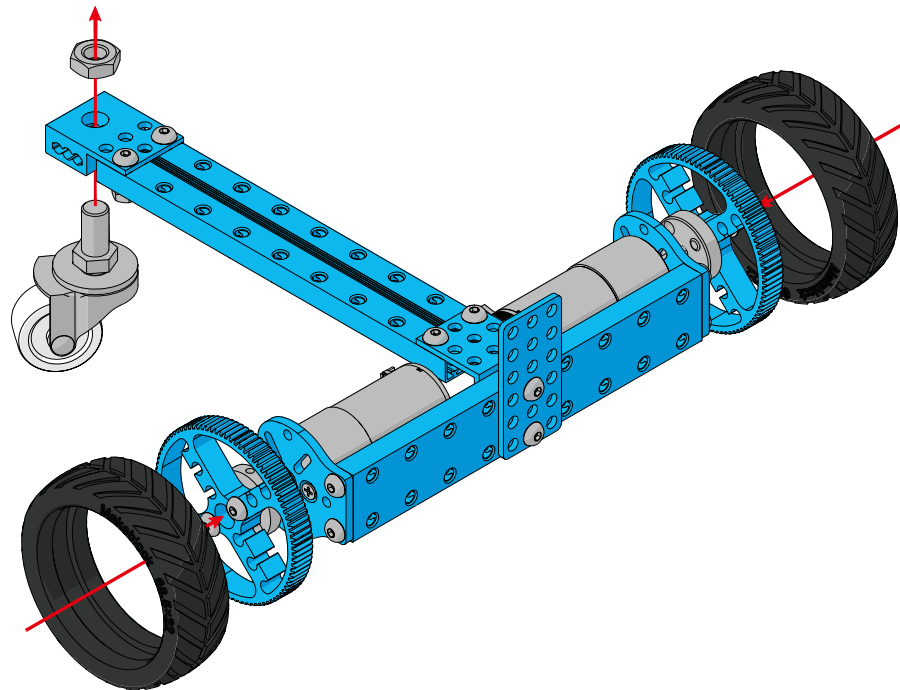

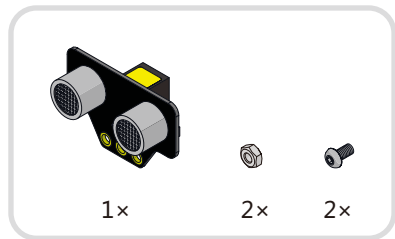

7

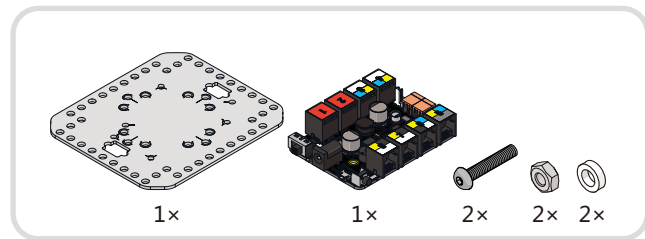
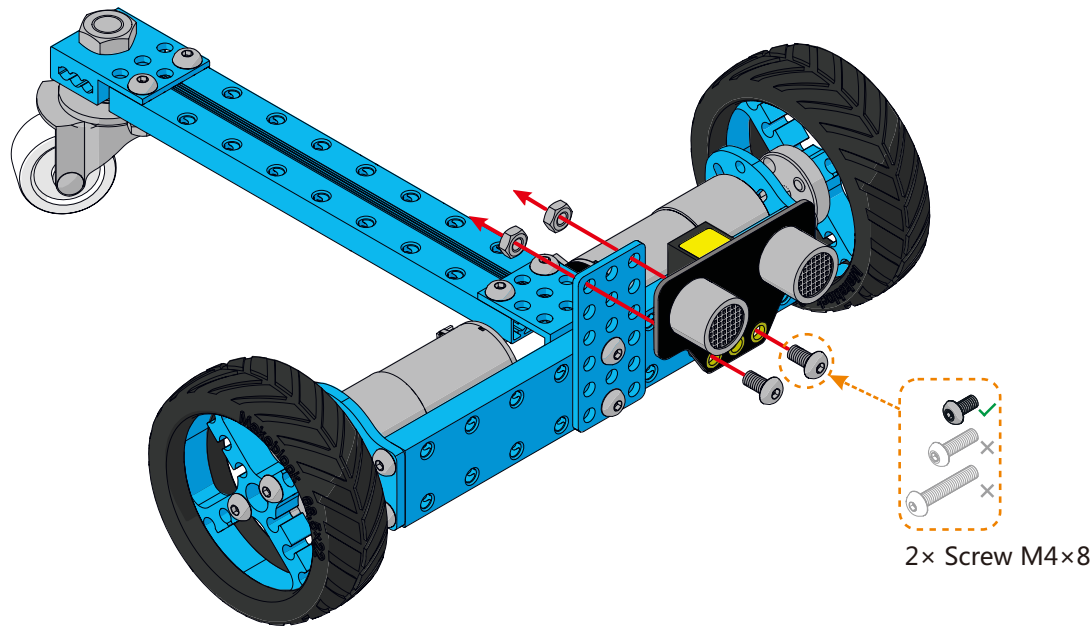

8

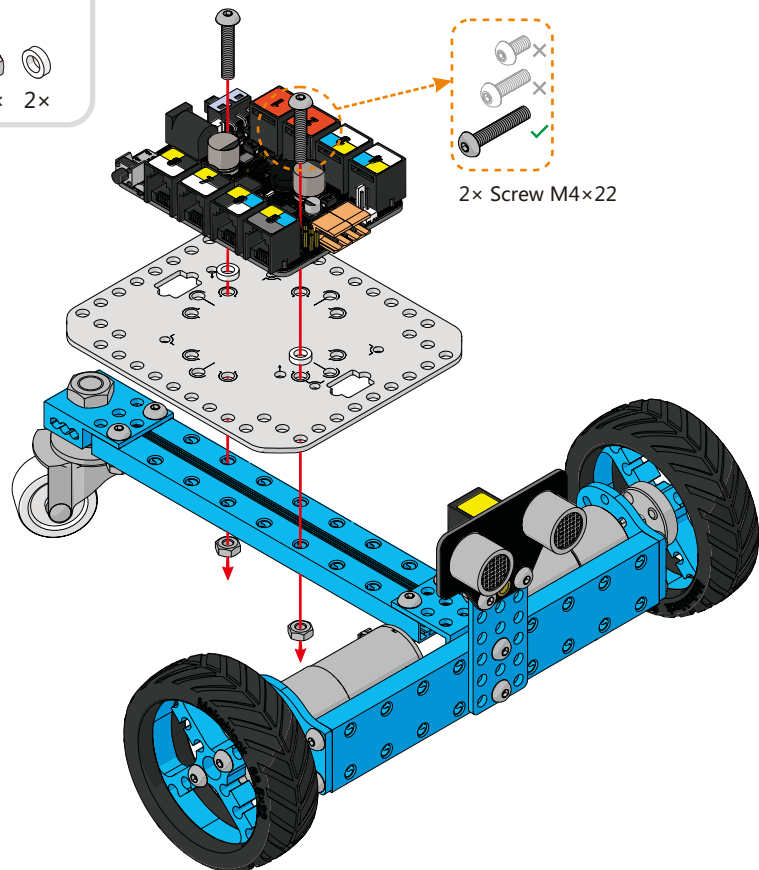

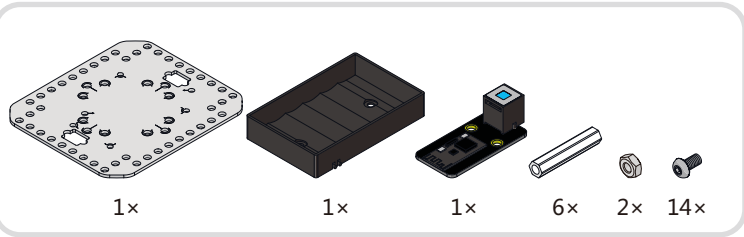

9

Please follow page 11 for wiring and app operation.

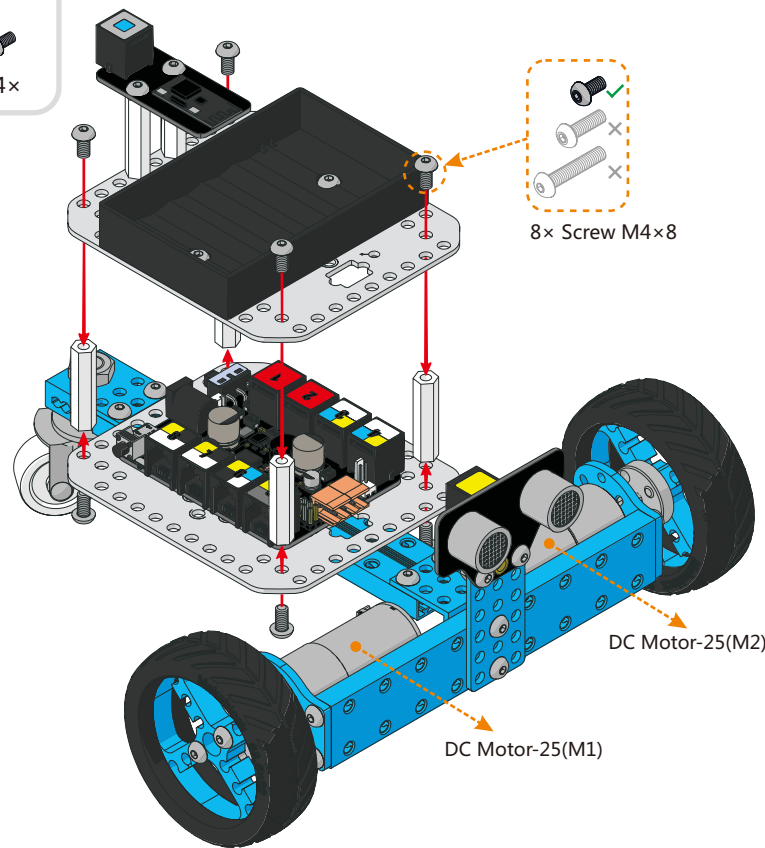
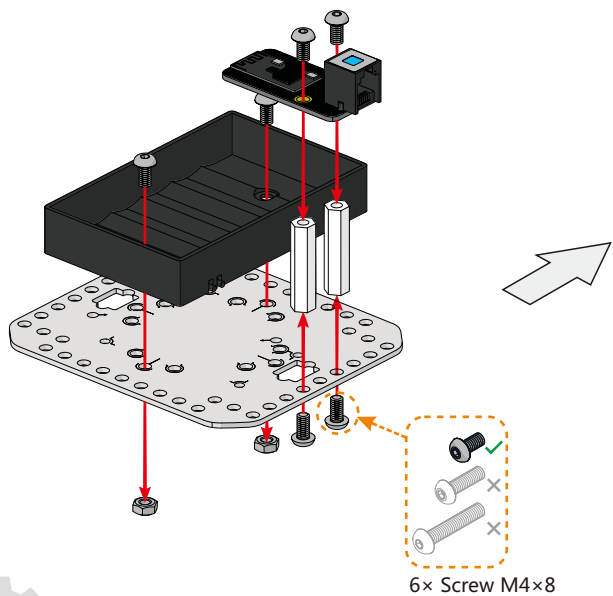

Programming--Further exploration

Working with mBlock--Hack the Physical World

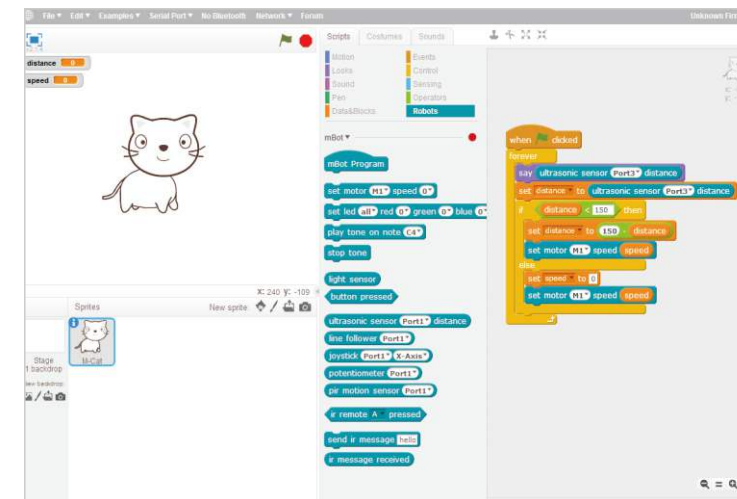

The Starter Robot Kit support mBlock perfectly which allow you re-programming your robot by simply drag and joint the blocks of mBlock. No more difficult coding.

mBlock is a free modified version of Scratch 2.0 developed by MIT Media Lab, mBlock add some hardware-related blocks in the original Scratch, with these blocks, users can read sensors, control motors and even a whole robot.

Besides blocks for the basic microcontroller functionalities, analog and digital writes and reads, PWM outputs. There are also blocks for each specific electronic modules, such as ultrasonic sensor, temperature sensor, light sensor, DC motor driver, stepper driver, etc. With these blocks, it's simple to interact with many kinds of electronic modules.

Visit the following URL for more details:
<http://learn.makeblock.cc/learning-scratch>











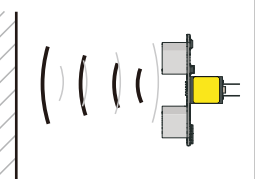

Working with Arduino IDE --Learn Programming the Fun Way

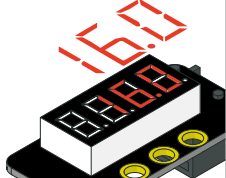
Arduino is an open-source electronics prototyping platform based on flexible , easy-to-use hardware and software.The Arduino software consists of a development environment (IDE) and the core libraries. The IDE is written in Java and based on the Processing development environment.

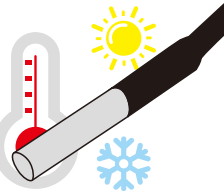
Visit the following URL for more details: <http://learn.makeblock.cc/learning-Arduino>
 Download the library zip package: <https://github.com/Makeblock-official/Makeblock-Library/archive/master.zip>

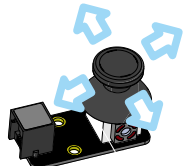

Electronic modules on makeblock--Further exploration

	<p>Ultrasonic module works for measuring distance from 3cm to 400cm.</p>			<p>Me Sound Sensor can measure the volume. It can be used in some sound interactive projects, such as a voice-operated switch.</p>	
	<p>Me 7-Segment Display is a display module with four digit tube which can show some data, such as speed, time, score, etc.</p>			<p>Me Temperature Sensor is a stainless steel tube sensor which is used for measuring temperature.</p>	
	<p>Me RGB LED module contains four programmable RGB LEDs. Color of each LED can be set by editing components of red, green, and blue.</p>			<p>Me PIR Motion Sensor can detect infrared rays which derive from animals/humans in less than 6 meters.</p>	
	<p>Me Joystick is normally used to control the movement direction of an object.</p>		<p>see more on makeblock platform</p>		

Kits on Makeblock--Further exploration

