

BATTERY CONNECTORS

Reduced 2.5mm Pitch 9155-200

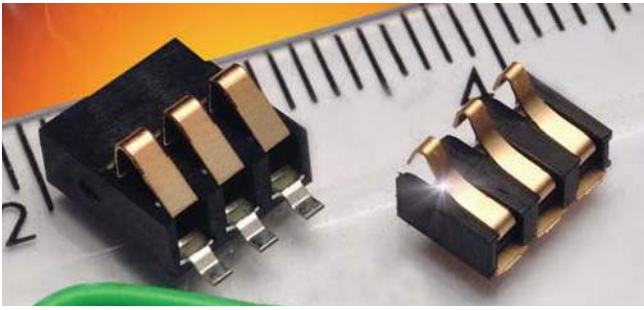

The newest product in KYOCERA AVX Interconnect family of battery connectors saves 50% in volume over the initial 9155 series compression connectors as illustrated in the photograph. These connectors are rated at a full 3 amps per contact on 2.5mm centers. Sizes range from 2 positions through 5 positions and are end to end stackable.

APPLICATIONS

- Cellular Phones
- Handheld Devices
- Industrial Modules
- Medical Electronics

FEATURES AND BENEFITS

- 2.4mm insulator height
- 3 amps/contact
- Large SMT mounting area for positive mechanical attachment
- 5k mating cycles
- End-to-end stackable

ELECTRICAL

- Current Rating: 3 Amp / Contact
- Voltage Rating: 125 VAC

ENVIRONMENTAL

- Operating Temperature: -40°C to +125°C

MECHANICAL

- Insulator Material: Glass-Filled Nylon 46; UL94 HB
- Contact Material: Beryllium Copper
- Plating: Gold over Nickel
- Durability: 5000 Cycles

HOW TO ORDER

00	9155	00X
Prefix	Series	No. of Ways
		2 = 002
		3 = 003
		4 = 004
		5 = 005

201				
Reduced Size Battery Connector				
<table border="1" style="width: 100%; border-collapse: collapse;"> <thead> <tr> <th style="width: 20%;">Code</th> <th>Description</th> </tr> </thead> <tbody> <tr> <td style="text-align: center;">201</td> <td>Reduced Size Battery Connector</td> </tr> </tbody> </table>	Code	Description	201	Reduced Size Battery Connector
Code	Description			
201	Reduced Size Battery Connector			

00X						
Plating Option						
<table border="1" style="width: 100%; border-collapse: collapse;"> <thead> <tr> <th style="width: 20%;">Code</th> <th>Description</th> </tr> </thead> <tbody> <tr> <td style="text-align: center;">006</td> <td>0.4µm Selective Gold, Standard</td> </tr> <tr> <td style="text-align: center;">008</td> <td>0.8µm Selective Gold, Special Order</td> </tr> </tbody> </table>	Code	Description	006	0.4µm Selective Gold, Standard	008	0.8µm Selective Gold, Special Order
Code	Description					
006	0.4µm Selective Gold, Standard					
008	0.8µm Selective Gold, Special Order					



BATTERY CONNECTORS

Reduced 2.5mm Pitch 9155-200

2 WAY REDUCED SIZE BATTERY CONNECTOR

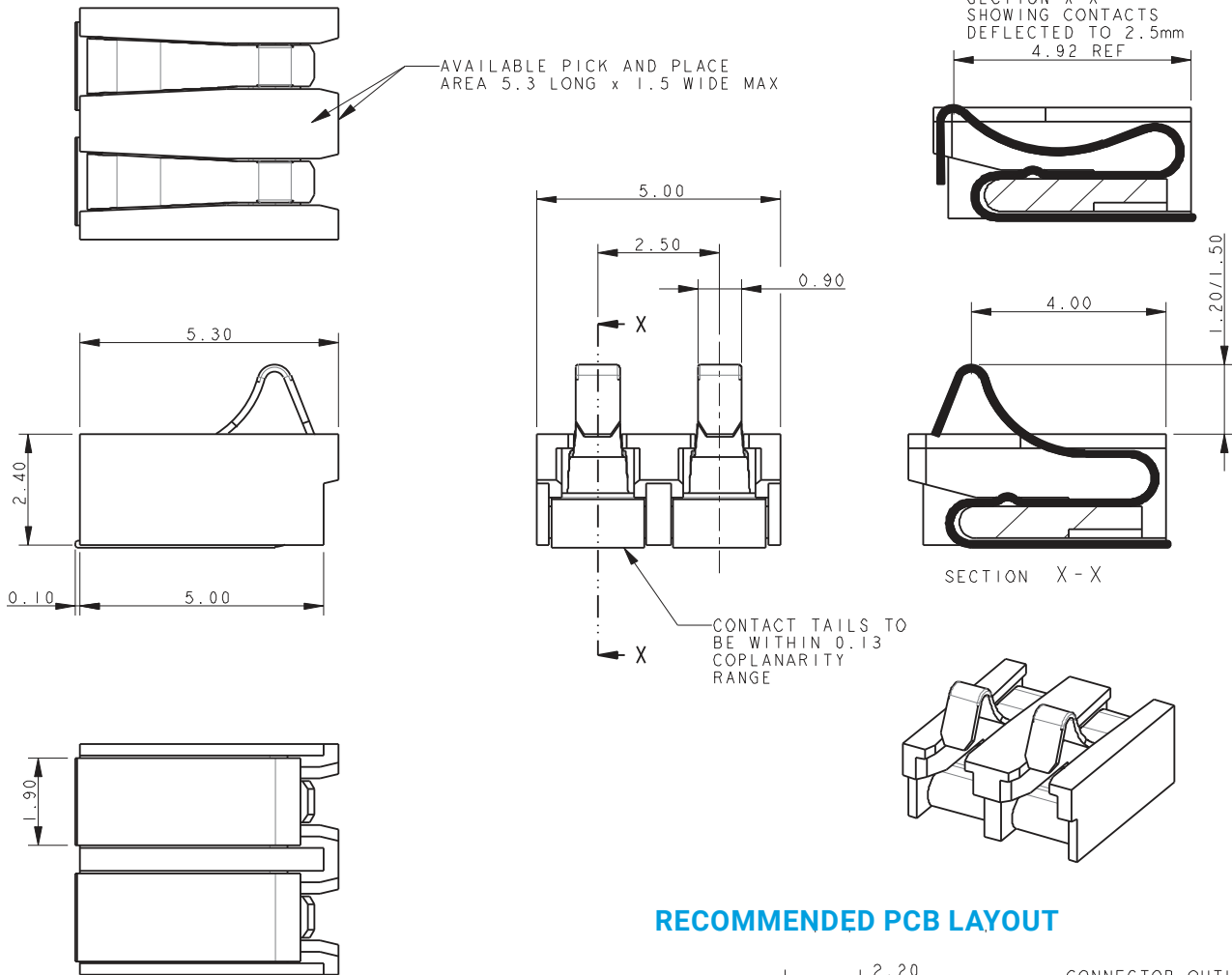

RECOMMENDED PCB LAYOUT

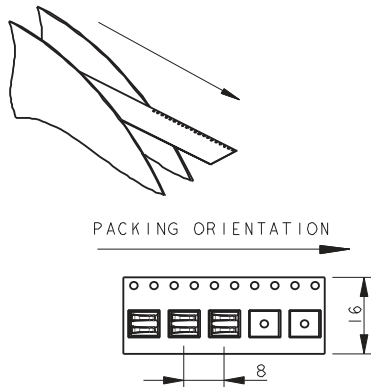
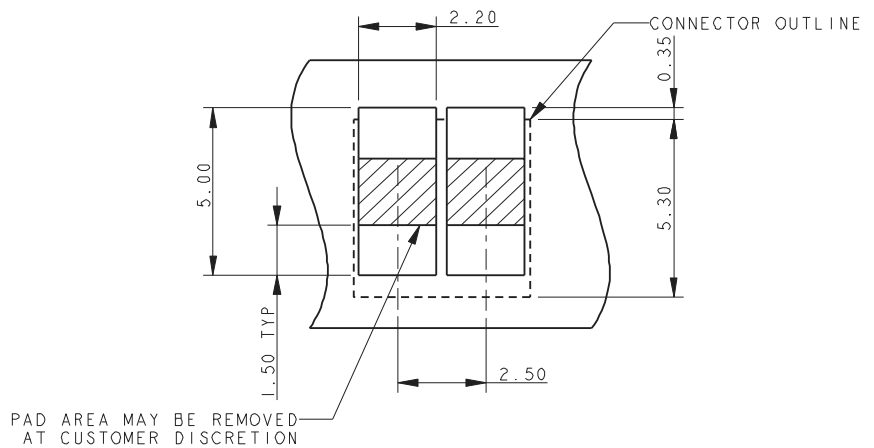

PACKING DETAILS

Reel Qty	2000
Leader	500MM
Trailer	500MM

NOTES:

1. FOR FULL PRODUCT SPECIFICATION REFER TO ELCO SPECIFICATION 201-01-093.
2. FOR MATING PAD DETAILS REFER TO PAGE 22.
3. GENERAL TOLERANCE ± 0.20 .
4. INSULATOR MATERIAL: 30% GLASS FILLED NYLON 46, UL94 HB, COLOR BLACK.
5. CONTACT MATERIAL: BERYLLIUM COPPER.
6. CONTACT PLATING: SELECTIVE GOLD OVER NICKEL. PURE TIN ON TAILS.

BATTERY CONNECTORS

Reduced 2.5mm Pitch 9155-200

3 WAY REDUCED SIZE BATTERY CONNECTOR

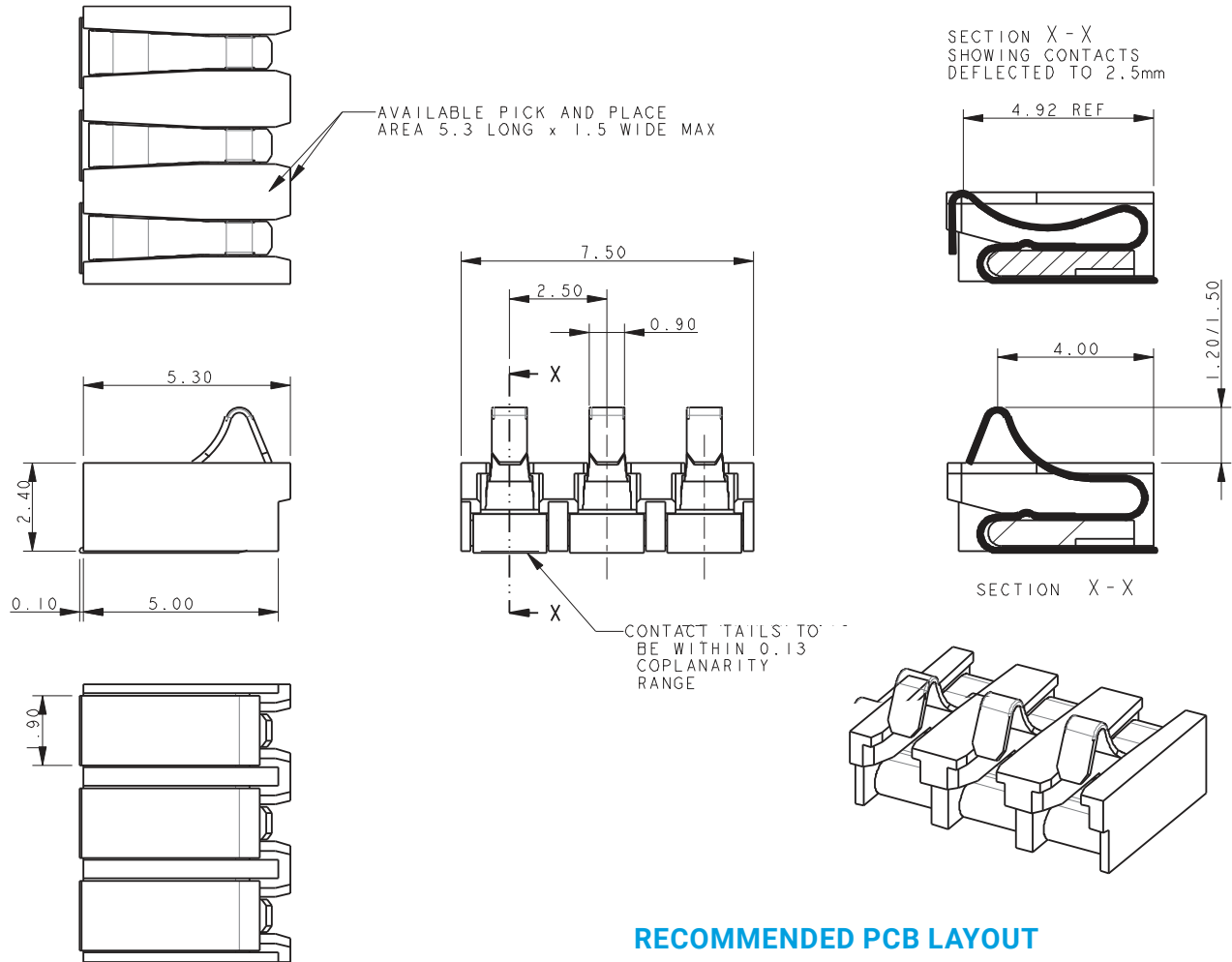

RECOMMENDED PCB LAYOUT

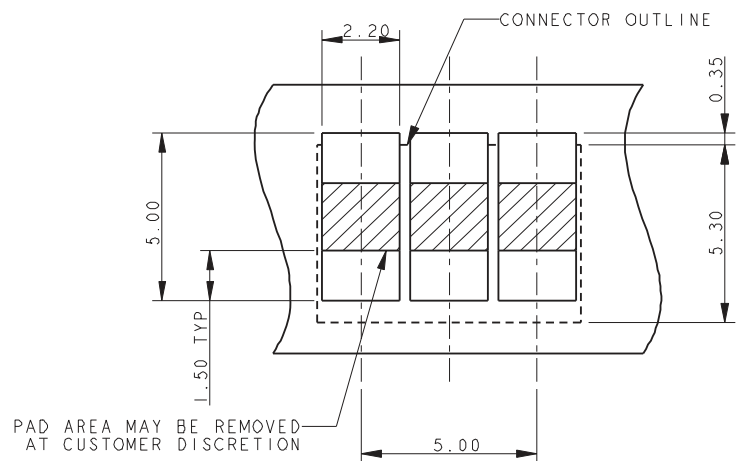
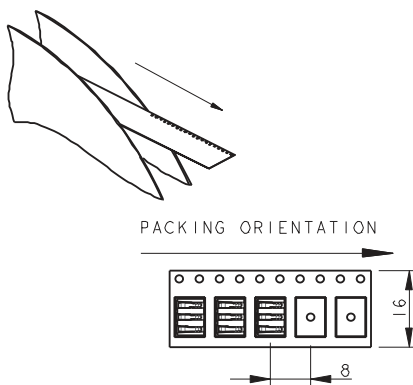

PACKING DETAILS

REEL QTY	2000
LEADER	500MM
TRAILER	500MM

NOTES:

1. FOR FULL PRODUCT SPECIFICATION REFER TO ELCO SPECIFICATION 201-01-093.
2. FOR MATING PAD DETAILS REFER TO PAGE 22.
3. GENERAL TOLERANCE ± 0.20 .
4. INSULATOR MATERIAL: 30% GLASS FILLED NYLON 46, UL94 HB, COLOR BLACK.
5. CONTACT MATERIAL: BERYLLIUM COPPER.
6. CONTACT PLATING: SELECTIVE GOLD OVER NICKEL. PURE TIN ON TAILS.

BATTERY CONNECTORS

Reduced 2.5mm Pitch 9155-200

4 WAY REDUCED SIZE BATTERY CONNECTOR

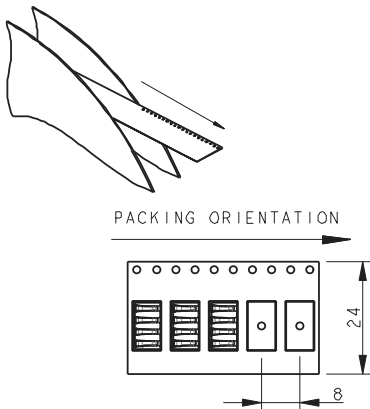
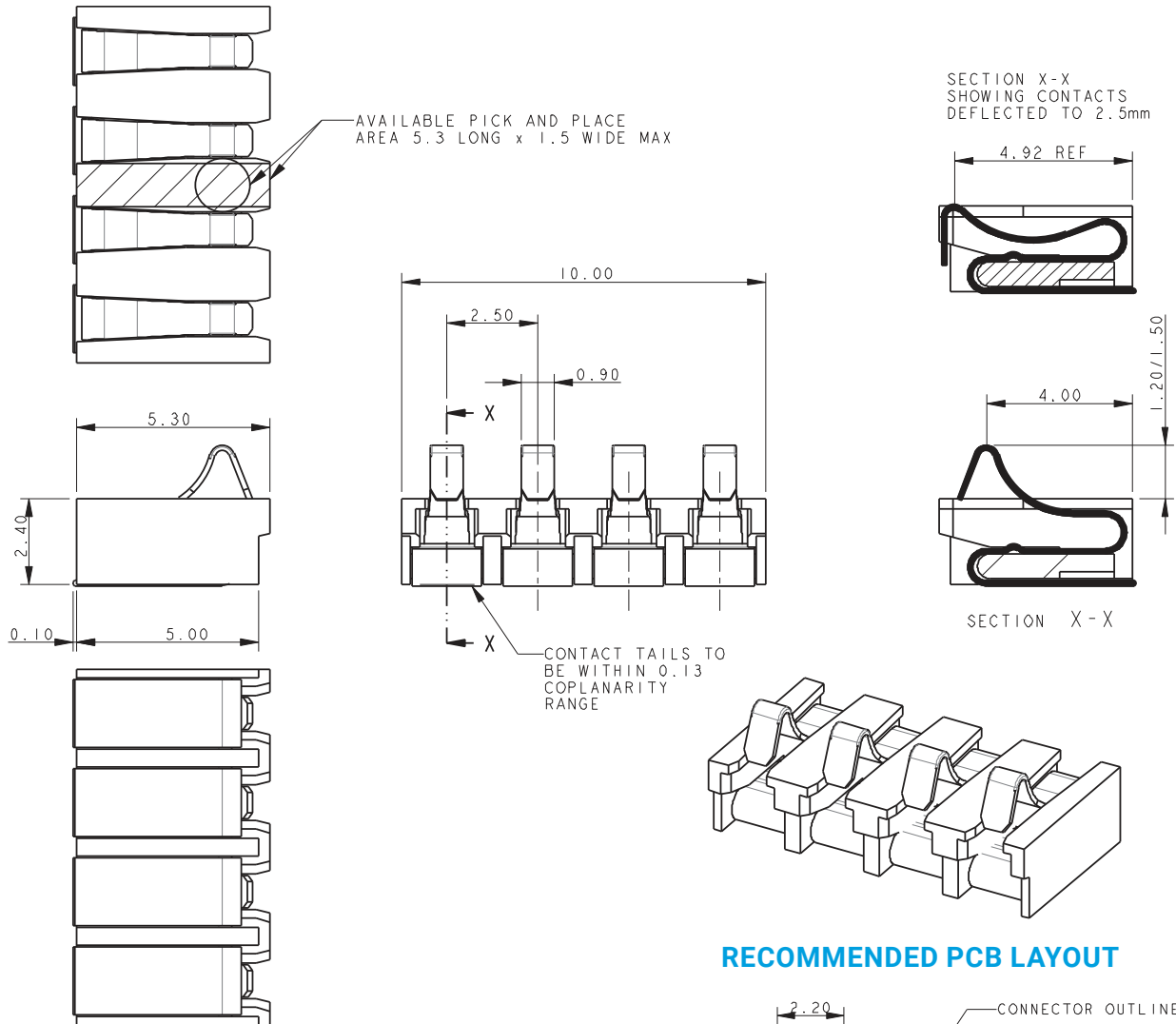

PACKING DETAILS

REEL QTY	2000
LEADER	500MM
TRAILER	500MM

RECOMMENDED PCB LAYOUT

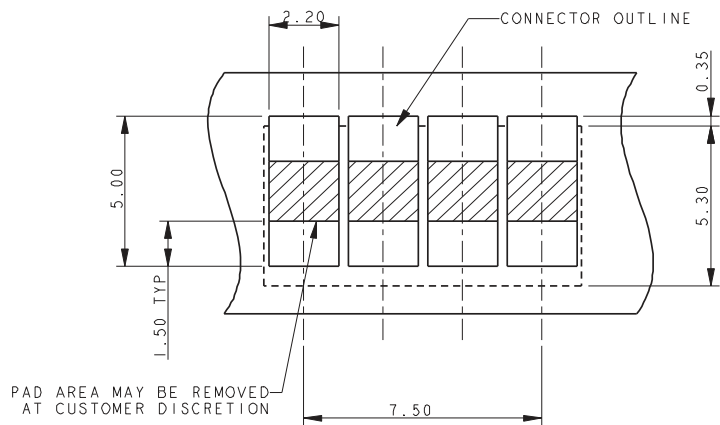

NOTES:

1. FOR FULL PRODUCT SPECIFICATION REFER TO ELCO SPECIFICATION 201-01-093.
2. FOR MATING PAD DETAILS REFER TO PAGE 22.
3. GENERAL TOLERANCE ± 0.20 .
4. INSULATOR MATERIAL: 30% GLASS FILLED NYLON 46, UL94 HB, COLOR BLACK.
5. CONTACT MATERIAL: BERYLLIUM COPPER.
6. CONTACT PLATING: SELECTIVE GOLD OVER NICKEL. PURE TIN ON TAILS.

BATTERY CONNECTORS

Reduced 2.5mm Pitch 9155-200

5 WAY REDUCED SIZE BATTERY CONNECTOR

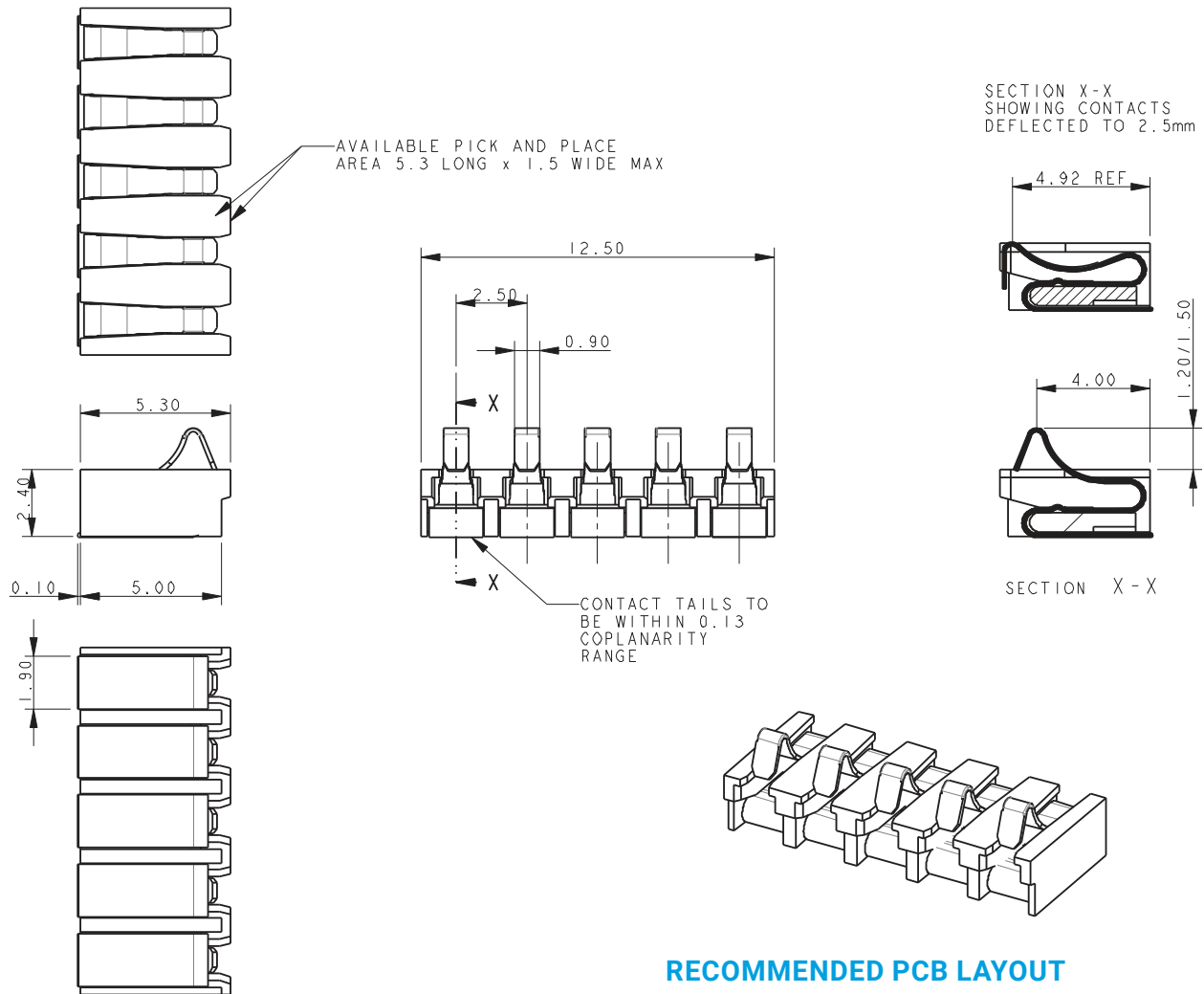

RECOMMENDED PCB LAYOUT

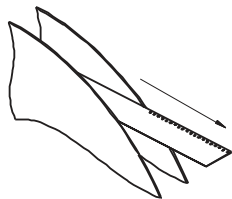
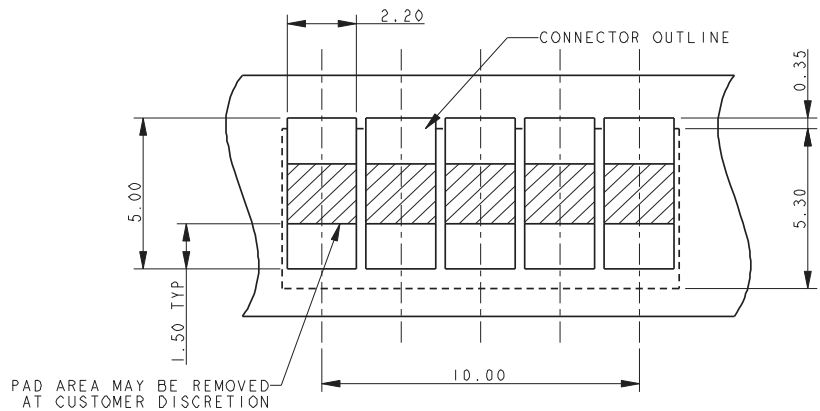

PACKING ORIENTATION

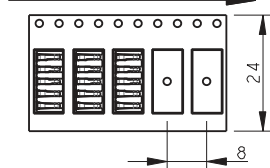

PACKING DETAILS

REEL QTY	2000
LEADER	500MM
TRAILER	500MM

NOTES:

1. FOR FULL PRODUCT SPECIFICATION REFER TO ELCO SPECIFICATION 201-01-093.
2. FOR MATING PAD DETAILS REFER TO PAGE 22.
3. GENERAL TOLERANCE ± 0.20 .
4. INSULATOR MATERIAL: 30% GLASS FILLED NYLON 46, UL94 HB, COLOR BLACK.
5. CONTACT MATERIAL: BERYLLIUM COPPER.
6. CONTACT PLATING: SELECTIVE GOLD OVER NICKEL. PURE TIN ON TAILS.

REDUCED SIZE BATTERY CONNECTOR – MATING PADS

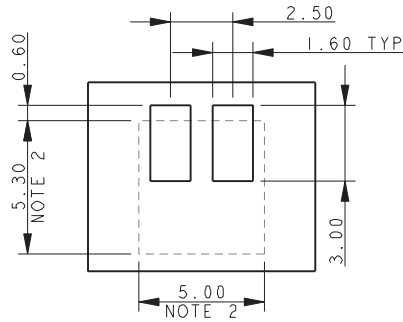

2 WAY MATING PADS

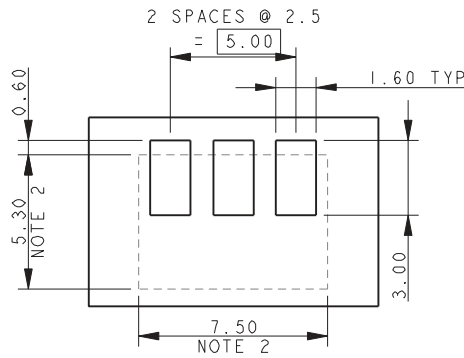

3 WAY MATING PADS

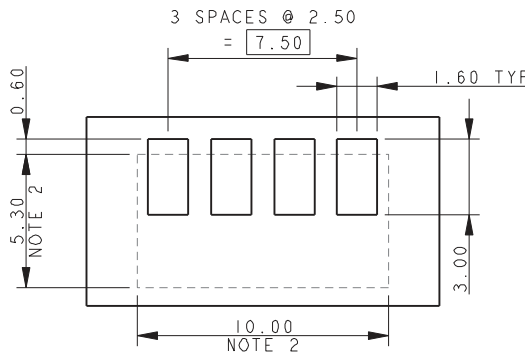

4 WAY MATING PADS

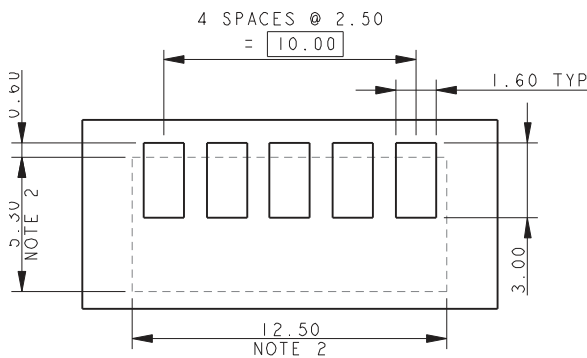

5 WAY MATING PADS

NOTES:

1. SUGGESTED MATING PADS FOR REDUCED SIZE BATTERY CONNECTORS.
2. OUTLINE OF CONNECTOR.
3. PREFERRED PLATING ON PADS GOLD OVER NICKEL.
4. REFERENCE DIMENSIONS.