

REF. -49 OPT. SCREW  
(WHERE APPLICABLE)

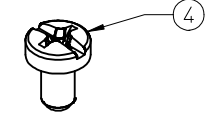

REF. -50 OPT. SCREW  
(WHERE APPLICABLE)

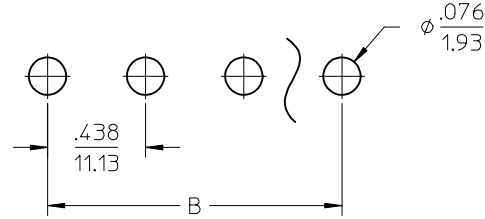
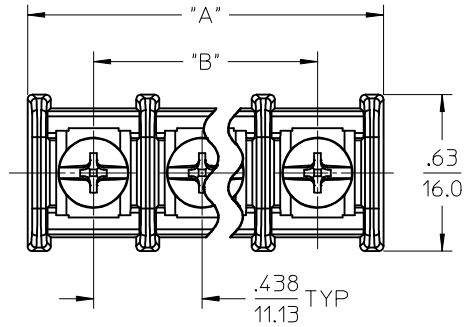
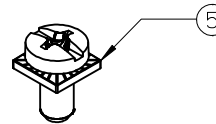

PTH PATTERN

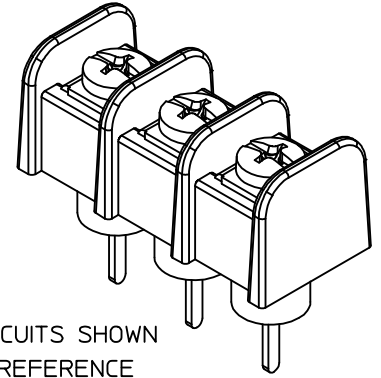

3 CIRCUITS SHOWN  
AS REFERENCE

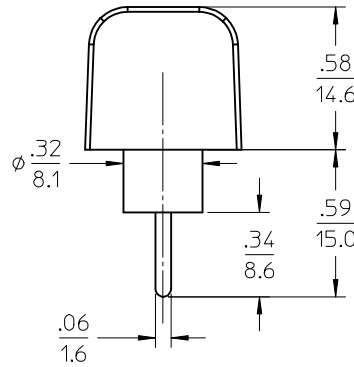
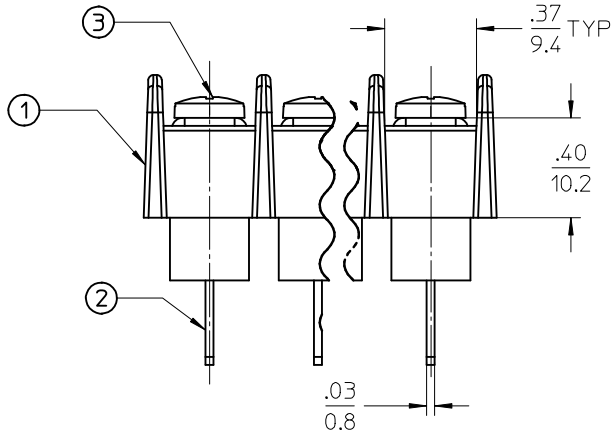

PART NUMBER LEGEND

74-3-XX-XX

SERIES

TERMINAL STYLE

CIRCUIT QTY (2 TO 30)

OPTION (-49 BRASS,PHIL/SLOT SCREW)

(-50 CLAMP WASHER,PHIL/SLOT SCREW)

(-C NO MOUNTING ENDS)

NOTES:

1. MATERIAL: SEE TABLE.
2. FINISHES: SEE TABLE.
3. PRODUCT SPECIFICATION: PS-38730-001
4. ASSEMBLY IS RoHS COMPLIANT.
5. "XX" REFERS TO THE QTY OF CIRCUITS.

5	XX	SCREW #6-32X.250 PAN PHSLZN/BR/STEEL -50	STEEL	ZINC
4	XX	SCREW #6-32X.250 BHD PHSLNI/BRASS LUBE -49	BRASS	NICKEL
3	XX	SCREW #6-32X.250 BHD PHSLZN/STEEL LUBE	STEEL	ZINC
2	XX	TERM TURRET 6C SN/B	BRASS	TIN
1	1	SR BTS INSUL MO C	POLYESTER (PBT)	BLACK
ITEM	QTY.	DESCRIPTION	MATERIAL	FINISH

RELEASED	EC NO: IPG2016-0008
DRAWN: SVMURTHY	2015/07/08
CHKD: RSTONE	2015/07/08
APPR: JFMURPHY	2016/07/11
REV	DESCRIPTION
A	

QUALITY SYMBOLS	▽/0
	▽/0
	▽/0

GENERAL TOLERANCES (UNLESS SPECIFIED)	mm	INCH
	4 PLACES ± --- ± ---	3 PLACES ± --- ± .005
	2 PLACES ± 0.13 ± .01	1 PLACE ± 0.3 ± ---
	0 PLACE ± --- ± ---	
ANGULAR ± 2 °		
DRAFT WHERE APPLICABLE MUST REMAIN WITHIN DIMENSIONS		

DIMENSION STYLE	
IN/MM	
DRAWN BY	DATE
SVMURTHY	2015/07/08
CHECKED BY	DATE
RSTONE	2015/07/08
APPROVED BY	DATE
JFMURPHY	2016/07/11
MATERIAL NO.	
SEE SHEET 2	
SIZE	
B	

SCALE	DESIGN UNITS	THIRD ANGLE PROJECTION
2:1	INCH	☉ □
TITLE		
11.13MM [.438"] SR BTS ASSY, INSULATED TURRET TERM, NO MTG ENDS		
DOCUMENT NO.		
SD-38740-4802		
SHEET NO.		1 OF 2

THIS DRAWING CONTAINS INFORMATION THAT IS PROPRIETARY TO MOLEX INCORPORATED AND SHOULD NOT BE USED WITHOUT WRITTEN PERMISSION

# OF CIRCUITS "XX"	DIM. "A"		DIM. "B"	
	in	mm	in	mm
02	.97	25	.438	11.13
03	1.40	36	.876	22.24
04	1.84	47	1.313	33.35
05	2.28	58	1.751	44.46
06	2.72	69	2.188	55.58
07	3.15	80	2.626	66.69
08	3.59	91	3.063	77.80
09	4.03	102	3.501	89.91
10	4.47	113	3.938	100.03
11	4.90	125	4.376	111.14
12	5.34	136	4.813	122.25
13	5.78	147	5.251	133.36
14	6.22	158	5.688	144.48
15	6.65	169	6.126	155.59
16	7.09	180	6.563	166.70
17	7.53	191	7.001	177.81
18	7.97	202	7.438	188.93
19	8.40	213	7.876	200.04
20	8.84	225	8.313	211.15
21	9.28	236	8.751	222.26
22	9.72	247	9.188	233.38
23	10.15	258	9.626	244.49
24	10.59	269	10.063	255.60
25	11.03	280	10.501	266.71
26	11.47	291	10.938	277.83
27	11.90	302	11.376	288.94
28	12.34	313	11.813	300.05
29	12.78	325	12.251	311.16
30	13.22	336	12.688	322.28

RELEASED EC NO: IFC2016-0008 DRAWN: SVMURTHY 2015/07/08 CHKD: RSTONE 2015/07/08 APPR: JFMURPHY 2016/07/11	DESCRIPTION REV A	QUALITY SYMBOLS	GENERAL TOLERANCES (UNLESS SPECIFIED)	DIMENSION STYLE	SCALE	DESIGN UNITS	THIRD ANGLE PROJECTION
		$\nabla F/0$ $\nabla E/0$ $\nabla D/0$	mm INCH 4 PLACES ± --- ± --- 3 PLACES ± --- ± .005 2 PLACES ± 0.13 ± .01 1 PLACE ± 0.3 ± --- 0 PLACE ± --- ± ---	IN/MM	2:1	INCH	TITLE 11.13MM [.438"] SR BTS ASSY, INSULATED TURRET TERM, NO MTG ENDS <b>molex</b> MATERIAL NO. 387404802 DOCUMENT NO. SD-38740-4802 SHEET NO. 2 OF 2
		ANGULAR ± 2 ° DRAFT WHERE APPLICABLE MUST REMAIN WITHIN DIMENSIONS	DRAWN BY DATE SVMURTHY 2015/07/08 CHECKED BY DATE RSTONE 2015/07/08 APPROVED BY DATE JFMURPHY 2016/07/11				
		SIZE B THIS DRAWING CONTAINS INFORMATION THAT IS PROPRIETARY TO MOLEX INCORPORATED AND SHOULD NOT BE USED WITHOUT WRITTEN PERMISSION					