

DESCRIPTION

The MP3366 is a step-up converter with 6-channel current sources designed to drive white LED arrays for backlighting in mid- to large-sized LCD panels.

The MP3366 uses peak-current mode as its PWM control architecture. The switching frequency can be programmed by a resistor. The MP3366 generates an output voltage up to 45V from a 3V-to-25V input supply. The MP3366 regulates the current in each LED string independently to the value set by an external current-setting resistor.

The MP3366 applies six internal current sources in each LED string terminal to achieve a current balance with 1.5% current regulation accuracy between strings. Its low 500mV regulation voltage on the LED current sources reduces power loss.

The MP3366 features mixed digital PWM dimming and analog dimming with a 25% PWM duty cycle as a transfer point. The mix-dimming strategy helps to improve the dimming ratio. The MP3366 switches the PWM input signal from 100Hz to 20kHz to 23.5kHz to 29.5kHz automatically to eliminate audible noise.

Full protection features include recoverable over-current protection (OCP), over-voltage protection (OVP), over-temperature protection (OTP), and short and open protection of any string on the LED.

The MP3366 is available in a WLCSP-18(1.35mmx2.55mm) package.

FEATURES

- 6-String, Max 45mA/String
- 3V to 25V Input Voltage Range
- 1.5% Current Matching Accuracy between Strings
- 600kHz Switching Frequency
- Combined Analog and PWM Dimming Mode with 25% Dimming Transfer Point
- 23.5kHz to 29.5kHz Output Dimming Frequency to Eliminate Audible Noise
- Programmable Over-Voltage Protection (OVP)
- Open and Short LED String Protection
- Recoverable Thermal Shutdown Protection
- Cycle-by-Cycle Over-Current Protection (OCP)
- Under-Voltage Lockout (UVLO)
- Available in a WLCSP-18(1.35mmX2.55mm) Package

APPLICATIONS

- Tablets
- Notebooks
- Terminal Displays

All MPS parts are lead-free, halogen-free, and adhere to the RoHS directive. For MPS green status, please visit the MPS website under Quality Assurance. "MPS" and "The Future of Analog IC Technology" are registered trademarks of Monolithic Power Systems, Inc.

TYPICAL APPLICATION

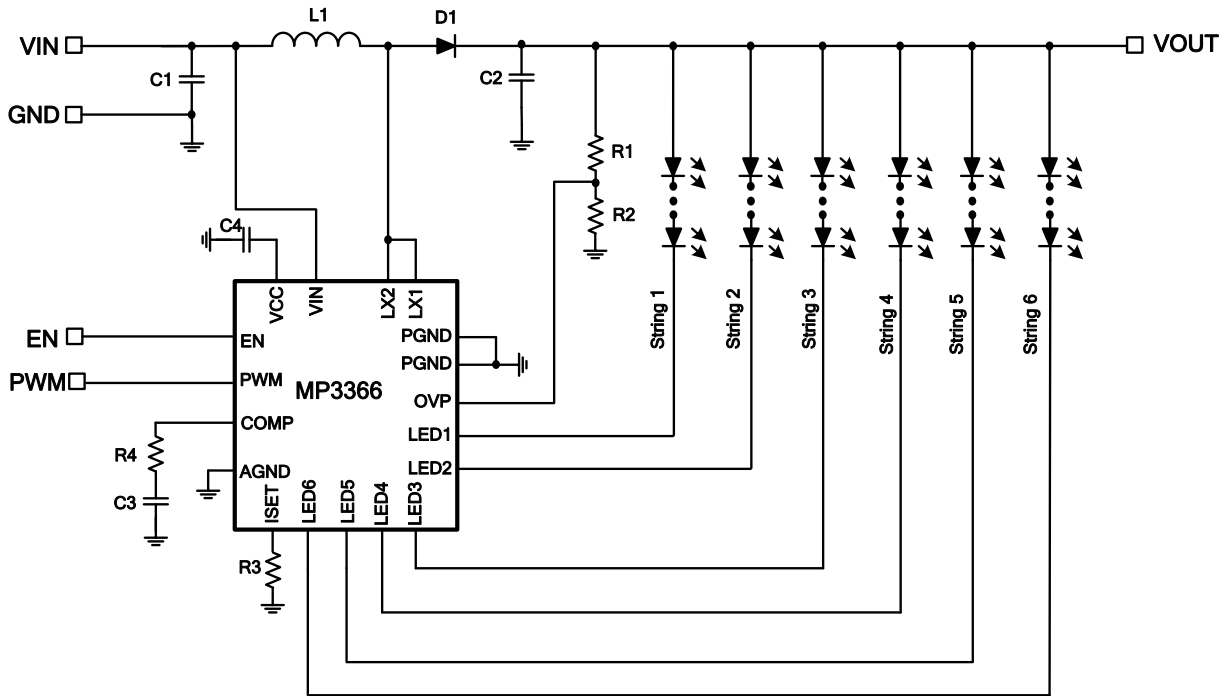

ORDERING INFORMATION

Part Number*	Package	Top Marking
MP3366GC	WLCSP-18 (1.35mmx2.55mm)	See Below

* For Tape & Reel, add suffix -Z (e.g. MP3366GC-Z)

TOP MARKING

—
AMZ

YWW

LLL

AMZ: Product code of MP3366GC

Y: Year code

WW: Week code

LLL: Lot number

PACKAGE REFERENCE

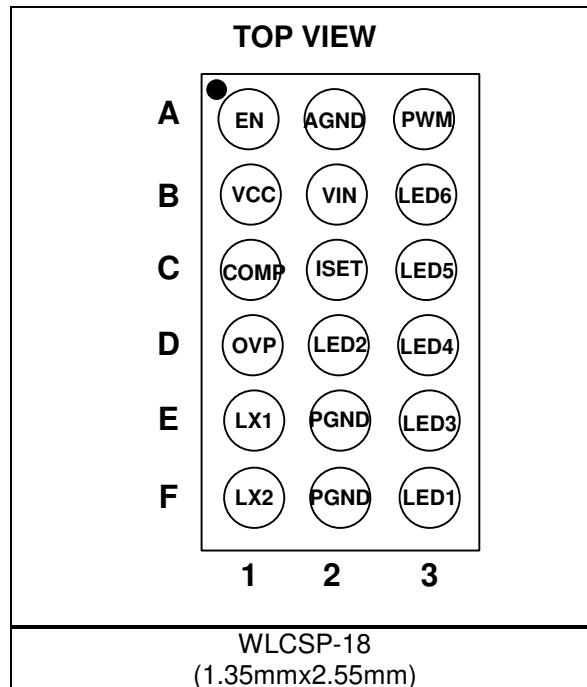

ABSOLUTE MAXIMUM RATINGS⁽¹⁾

V_{PWM}, V_{EN}, V_{IN}	-0.3V to +30V
VCC.....	-0.3V to +6.5V
V_{LX}, V_{LED1} to V_{LED6}	-1V to +50V
All other pins.....	-0.3V to +6V
Junction temperature	150°C
Lead temperature	260°C
Continuous power dissipation ($T_A = 25^\circ\text{C}$) ⁽²⁾	
WLCSP-18(1.35mmx2.55mm)	1.7W

Recommended Operating Conditions⁽³⁾

Supply voltage (V_{IN})	3V to 25V
Operating junction temp.....	-40°C to +125°C

Thermal Resistance⁽⁴⁾	θ_{JA}	θ_{JC}
WLCSP-18(1.35mmx2.55mm) ..	70...1°C/W

NOTES:

- 1) Exceeding these ratings may damage the device.
- 2) The maximum allowable power dissipation is a function of the maximum junction temperature T_J (MAX), the junction-to-ambient thermal resistance θ_{JA} , and the ambient temperature T_A . The maximum allowable continuous power dissipation at any ambient temperature is calculated by P_D (MAX) = $(T_J$ (MAX) - T_A) / θ_{JA} . Exceeding the maximum allowable power dissipation produces an excessive die temperature, causing the regulator to go into thermal shutdown. Internal thermal shutdown circuitry protects the device from permanent damage.
- 3) The device is not guaranteed to function outside of its operating conditions.
- 4) Measured on JESD51-7, 4-layer PCB.

ELECTRICAL CHARACTERISTICS
 $V_{IN} = 3.7V$, $V_{EN} = V_{IN}$, $T_A = 25^\circ C$, unless otherwise noted.

Parameters	Symbol	Condition	Min	Typ	Max	Units
Operating input voltage	V_{IN}		3		25	V
Supply current (quiescent)	I_Q	No load		1.6		mA
Supply current (shutdown)	I_{ST}	$V_{EN} = 0V$			1	μA
LDO output voltage	V_{CC}	$6V < V_{IN} < 25V$, $0 < I_{VCC} < 10mA$	4.5	5	5.5	V
VCC UVLO threshold	V_{IN_UVLO}	Rising edge	2.42	2.57	2.72	V
VCC UVLO hysteresis				80		mV
EN on threshold	V_{EN_ON}	V_{EN} rising	1.5			V
EN off threshold	V_{EN_OFF}	V_{EN} falling			0.8	V
Step-Up Converter						
SW on resistance	R_{DS_ON}	$I_{DS} = 20mA$		0.18	0.3	Ω
SW leakage current	I_{SW_LK}	$V_{SW} = 45V$			1	μA
Switching frequency	F_{SW}			600		kHz
Maximum duty cycle	D_{MAX}		90	93	96	%
SW current limit	I_{SW_LIMIT}	Duty = 90%		2.5		A
COMP transconductance	G_{COMP}	$\Delta I_{COMP} = \pm 10\mu A$		100		$\mu A/V$
Current Dimming						
PWM input low threshold	V_{PWM_LO}	V_{PWM} falling			0.4	V
PWM input high threshold	V_{PWM_HI}	V_{PWM} rising	1.5			V
PWM dimming output frequency	F_{PWMO}		23.5k		29.5k	Hz
PWM dimming input transfer point				25		%
PWM dimming transfer point hysteresis				0.2		%
PWM leakage current	I_{PWM_LK}	$V_{PWM} = 5V$		10	15	μA
		$V_{PWM} = 0V$			1	μA
LED Current Regulation						
LEDX average current	I_{LED}	$R_{ISET} = 62k\Omega$	19.4	20	20.6	mA
Current matching ⁽⁵⁾		$I_{LED} = 20mA$			1.5	%
Maximum LED current per string	I_{LEDmax}				45	mA
ISET regulation voltage			1.205	1.235	1.265	V
LEDX regulation voltage	V_{LEDX}	$I_{LED} = 20mA$	400	500	600	mV

ELECTRICAL CHARACTERISTICS (continued)
 $V_{IN} = 3.7V$, $V_{EN} = V_{IN}$, $T_A = 25^{\circ}C$, unless otherwise noted.

Parameters	Symbol	Condition	Min	Typ	Max	Units
Protection						
Over-voltage protection threshold	V_{OVP_OV}	Rising edge	1.13	1.2	1.29	V
OVP UVLO threshold	V_{OVP_UV}	Step-up converter fails	40	75	105	mV
LEDX over-voltage threshold	V_{LEDX_OV}	$V_{IN} > 5.5V$	5	5.5	6	V
LEDX UVLO threshold	V_{LEDX_UV}		160	265	360	mV
Thermal shutdown threshold	T_{ST}			150		$^{\circ}C$
Thermal shutdown hysteresis				20		$^{\circ}C$
LEDX over-voltage fault timer		$F_S = 600kHz$	2.4	3.2	4	ms

NOTE:

5) Matching is defined as the difference of the maximum to minimum current divided by 2 times average current.

TYPICAL PERFORMANCE CHARACTERISTICS

$V_{IN} = 7V$, $V_{EN} = 5V$, 8 LEDs in series, 6 strings, 20mA/string, $T_A = 25^\circ C$, unless otherwise noted.

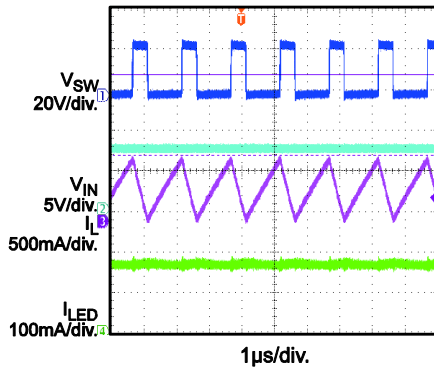
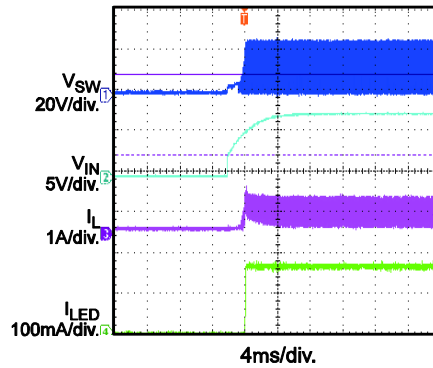
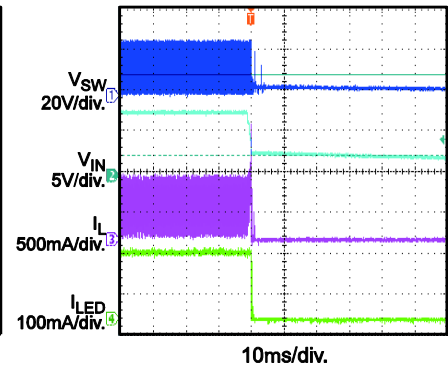
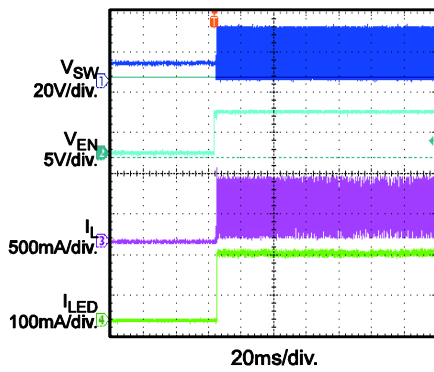
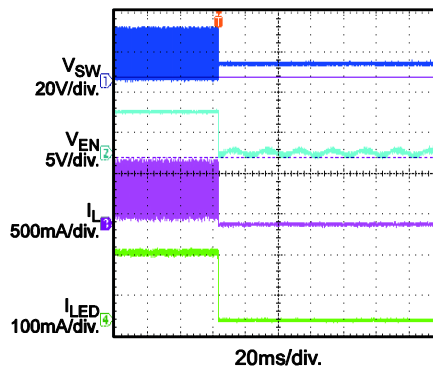
Steady State

 V_{IN} Power On

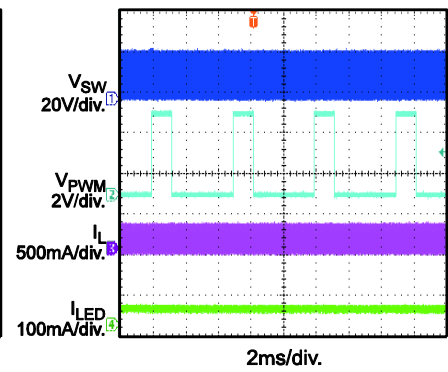
 V_{IN} Power Off

EN Power On

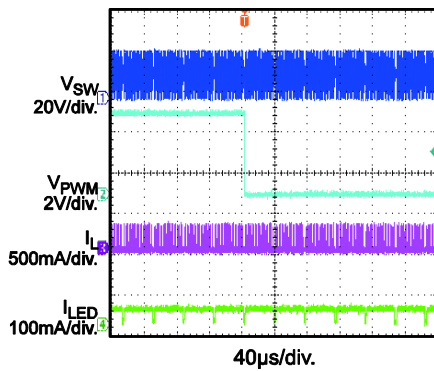
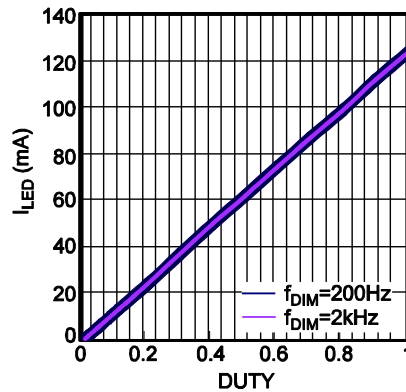
EN Power Off

Mix Dimming

$F_{PWM} = 200Hz$, $D_{PWM} = 25\%$

Mix Dimming

$F_{PWM} = 200Hz$, $D_{PWM} = 24\%$

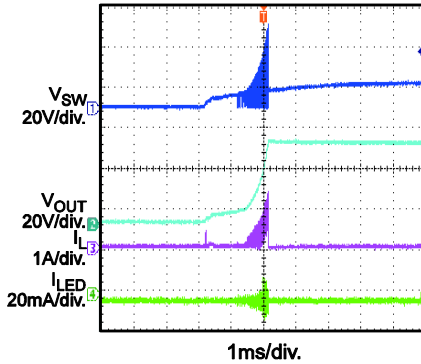
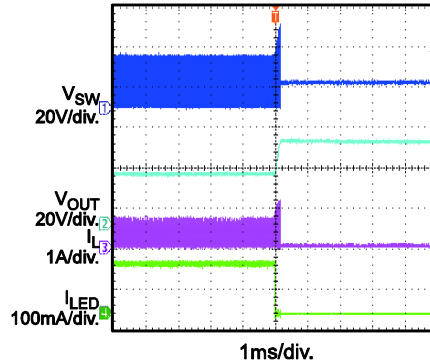
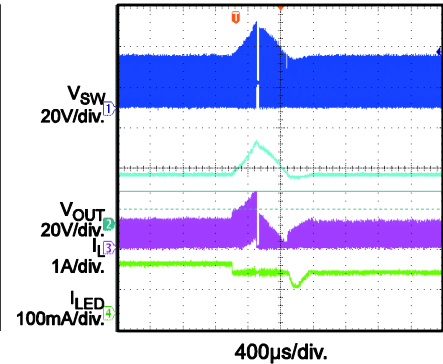
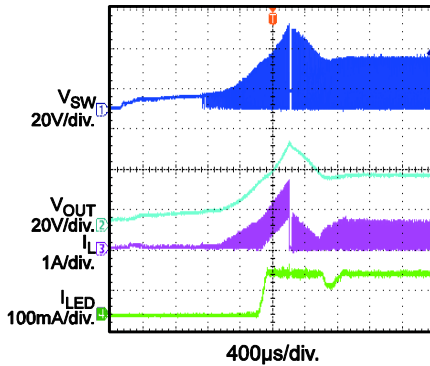
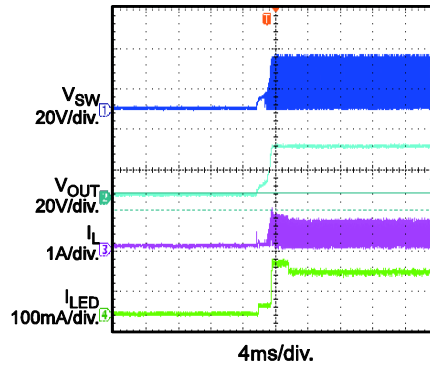
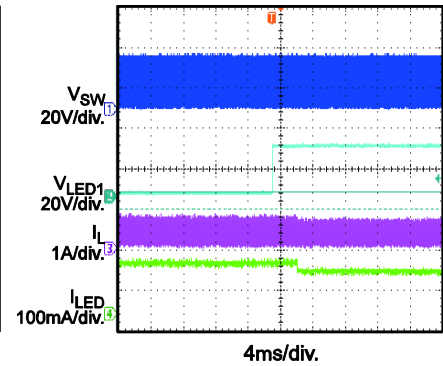
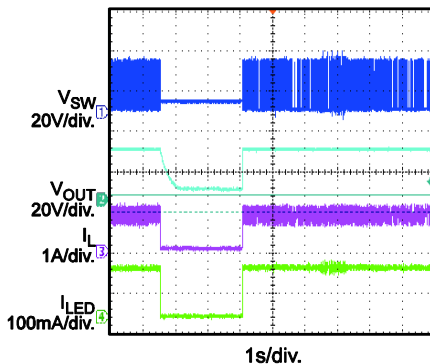

Mix Dimming Linearity

TYPICAL PERFORMANCE CHARACTERISTICS *(continued)*
 $V_{IN} = 7V$, $V_{EN} = 5V$, 8 LEDs in series, 6 strings, 20mA/string, $T_A = 25^\circ C$, unless otherwise noted.

**Start-Up
with Open Load**

**Open Load
when Working Normally**

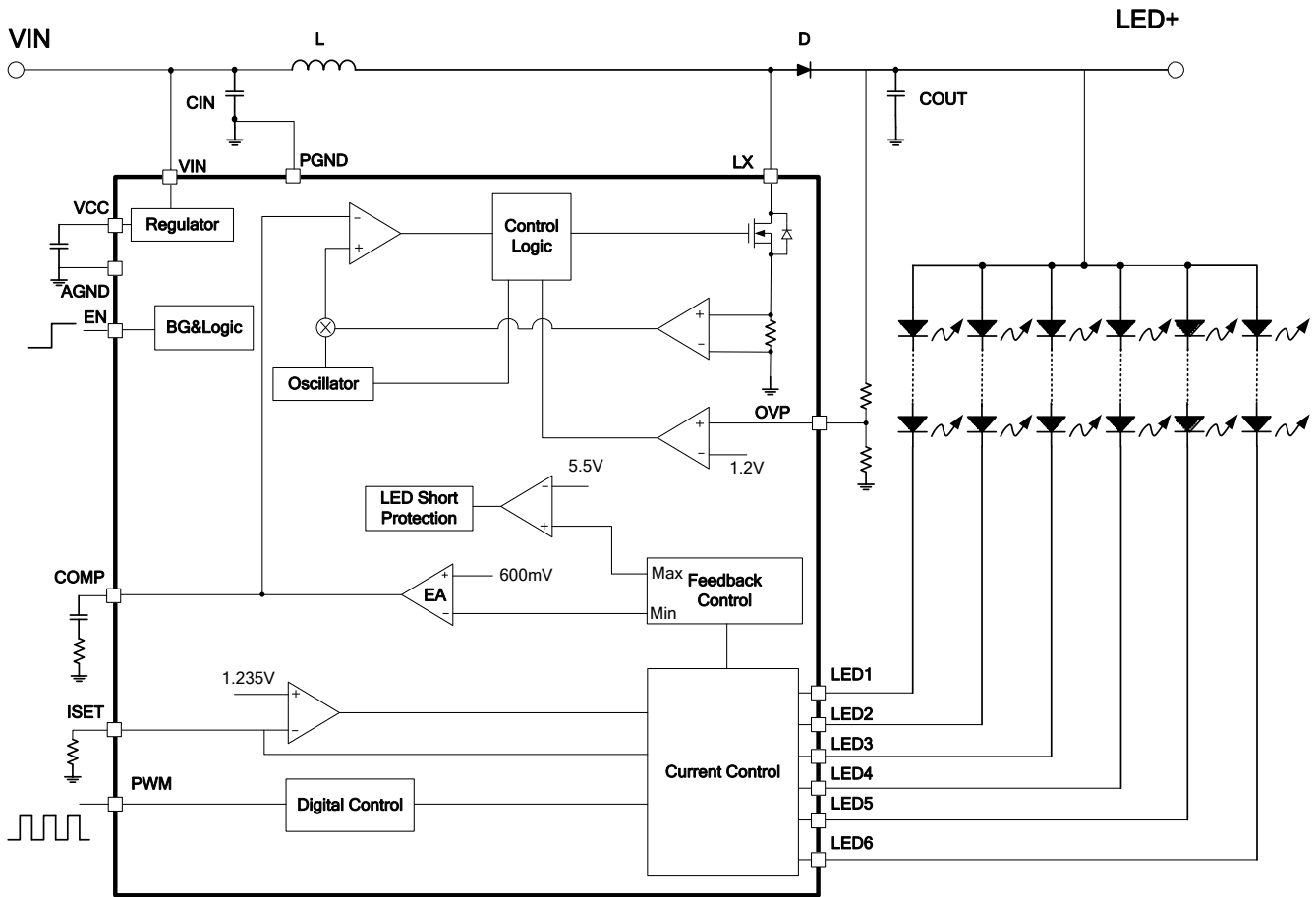
**Open 1 String
when Working Normally**

**Start-Up
when Open 1 String**

**Start-Up
when Short 1 String**

**Short 1 String
when Working Normally**

Thermal Protection

PIN FUNCTIONS

Package Pin #	Name	Description
A1	EN	Enable control input. EN is weakly pulled low internally.
A2	AGND	Analog ground.
A3	PWM	PWM signal input. Apply a PWM signal on PWM for brightness control. It is recommended to use the dimming signal with 100Hz to 20kHz. PWM is weakly pulled low internally.
B1	VCC	Internal 5V linear regulator output. VCC provides a power supply for the internal MOSFET switch gate driver and the internal control circuitry. Bypass VCC to GND with a ceramic capacitor. If VIN is less than 5.5V, tie VIN and VCC together.
B2	VIN	Power supply input. VIN supplies power to the IC. Drive VIN with a 3V-to-25V power source. VIN must be bypassed locally.
B3	LED6	LED string 6 current input. LED6 is the open-drain output of an internal dimming control switch. Connect the LED string 6 cathode to LED6.
C1	COMP	Step-up converter compensation. COMP is used to compensate for the regulation control loop. Connect a capacitor or a series RC network from COMP to GND.
C2	ISET	LED current setting. Tie a current setting resistor from ISET to ground to program the current in each LED string.
C3	LED5	LED string 5 current input. LED5 is the open-drain output of an internal dimming control switch. Connect the LED string 5 cathode to LED5.
D1	OVP	Over-voltage protection input. Connect a resistor divider from the output to OVP to program the OVP threshold.
D2	LED2	LED string 2 current input. LED2 is the open-drain output of an internal dimming control switch. Connect the LED string 2 cathode to LED2.
D3	LED4	LED string 4 current input. LED4 is the open-drain output of an internal dimming control switch. Connect the LED string 4 cathode to LED4.
E1, F1	LX1/2	Step-up converter power switch output. LX1/2 is the drain of the internal MOSFET switch. Connect the power inductor and output rectifier to LX1. LX1 and LX2 should be shorted externally.
E2, F2	PGND	Step-up converter power ground.
E3	LED3	LED string 3 current input. LED3 is the open-drain output of an internal dimming control switch. Connect the LED string 3 cathode to LED3.
F3	LED1	LED string 1 current input. LED1 is the open-drain output of an internal dimming control switch. Connect the LED string 1 cathode to LED1.

BLOCK DIAGRAM

Figure 1: Functional Block Diagram

OPERATION

The MP3366 employs a peak current as its PWM mode architecture and has 6-channel current sources to regulate the array of 6-string, white LEDs.

Internal 5V Regulator

The MP3366 has an internal linear regulator (VCC). When VIN is greater than 5.5V, this regulator offers a 5V power supply for the internal MOSFET switch-gate driver and the internal control circuitry. The VCC voltage drops to 0V when the chip shuts down. When VIN is smaller than 5.5V, tie VCC and VIN together. The MP3366 uses under-voltage lockout (UVLO) and disables the chip until VCC exceeds the UVLO threshold. The UVLO hysteresis is approximately 80mV.

System Start-Up

When enabled, the MP3366 checks the topology connection first. The chip monitors the over-voltage protection (OVP) pin to determine if the Schottky diode is connected or if the boost output is shorted to GND. An OVP voltage less than 75mV will fail to switch. The MP3366 also checks for other safety limits, including UVLO and over-temperature protection (OTP). If detections of all protections pass, then the chip begins boosting the step-up converter with an internal soft start.

The enable signal should occur after the establishment of the input voltage and PWM dimming signal during the start-up sequence to prevent a large inrush current.

Step-Up Converter

The converter operating frequency is fixed at 600kHz. At the beginning of each switching cycle, the internal clock turns on the internal MOSFET. In normal operation, the minimum turn-on time is 100ns. A stabilizing ramp added to the output of the current sense amplifier prevents subharmonic oscillations for duty cycles greater than 50%. The error amplifier and ramp voltages are fed into the PWM comparator. When the compared voltage reaches the output voltage of the error amplifier (V_{COMP}), the internal MOSFET turns off.

The output voltage of the internal error amplifier is an amplified signal of the difference between the reference voltage and the feedback voltage. The converter automatically chooses the lowest active LEDX voltage to provide a high enough bus voltage to power all of the LED arrays.

If the feedback voltage drops below the reference, the output of the error amplifier increases. More current flows through the MOSFET, increasing the power delivered to the output. This forms a closed loop that regulates the output voltage.

Under light-load operations, especially in the case of $V_{OUT} \approx V_{IN}$, the converter runs in pulse-skip mode, where the MOSFET turns on for a minimum on time of approximately 100ns before the converter discharges the power to the output for the remaining period. The external MOSFET remains off until the output voltage needs to be boosted again.

Dimming Control

The MP3366 works in combined analog and PWM dimming mode with 25% as its transfer point. A PWM signal is applied to the PWM pin. When the duty cycle of the PWM dimming signal is greater than or equal to 25%, the IC dims the LED current with analog mode, and the LED current amplitude equals $I_{SET} \cdot D_{DIM}$, where I_{SET} is the LED current set by a resistor connected to ISET, and D_{DIM} is the duty cycle of the PWM dimming signal. Analog dimming helps reduce LED power loss and prevents audible noise.

When the duty cycle of the PWM dimming signal is less than 25%, the IC dims the LED current in PWM mode. The LED current amplitude is fixed to $25\% \cdot I_{SET}$, while the LED dimming duty is four times D_{DIM} to make the actual average LED current equal to $I_{SET} \cdot D_{DIM}$. The actual LED current dimming frequency is transferred to the range of 23.5kHz~29.5kHz from 100Hz~20kHz of the input PWM dimming signal frequency. This way, the MP3366 improves the low LED current dimming ratio and prevents audible noise.

Output Over-Voltage Protection (OVP) and Short Protection

In some unexpected cases, to prevent the IC from continuously charging the output voltage, the MP3366 uses an over-voltage protection (OVP) function to protect the components from being damaged by the output voltage. If the OVP high protection threshold point (1.2V) is reached, the chip stops switching and the output voltage drops. The switching resumes if the OVP point drops below the recovery threshold.

The MP3366 can also achieve an output short to GND or diode open protection by detecting the OVP voltage. The IC works in normal switching operation only when the OVP voltage is higher than 75mV.

Open-String Protection

Open-string protection is achieved by detecting both the OVP pin and the LED (1 to 6) pins. If one or more strings (but not all strings) are open, the respective LEDX pins are pulled to ground and the IC continues charging the output voltage until OVP reaches the 1.2V protection threshold. The chip stops switching and marks off the open strings that have an LEDX pin voltage lower than 265mV. Once marked, the remaining LED strings force the output voltage back into its correct regulation. The string with the largest voltage drop determines the output regulation. The marked-off strings can also resume normal operation after they are connected back to the system.

If all six strings are open (LED bar is open), the IC continues charging the output voltage until the OVP voltage reaches the 1.2V threshold, and the LED current regulator is marked off. The IC resumes normal current regulation until VIN or EN is reset.

Short-String Protection

The MP3366 monitors the LEDX voltage to determine if a short string occurs. If one or more strings are short, the respective LEDX pins are pulled up to the boost output and tolerate high voltage stress. If the LEDX voltage is higher than 5.5V, the short-string condition is detected on the respective string. When the short-string fault (LEDX over-voltage fault) continues for more than 3.2ms, the corresponding string current regulator is disabled and disconnects from the output voltage loop regulation. The LED string resumes normal current regulation when the short condition is removed.

Thermal Shutdown

To prevent the IC from operating at exceedingly high temperatures, thermal shutdown is implemented by detecting the silicon die temperature. When the die temperature exceeds the upper threshold (T_{ST}), the IC shuts down and resumes normal operation when the die temperature drops below its lower threshold. Typically, the hysteresis value is 20°C.

APPLICATION INFORMATION

Setting the LED Current

The current of each string is identical and set through the current setting resistor on ISET, which can be determined with Equation (1):

$$I_{SET} = 1000 \times \frac{1.24(V)}{R_{SET}(k)} \quad (1)$$

When $R_{SET} = 62k\Omega$, set the LED current to 20mA. ISET cannot be open.

Selecting the Input Capacitor

The input capacitor reduces the surge current drawn from the input supply and the switching noise from the device. The input capacitor impedance at the switching frequency should be less than the input source impedance to prevent the high-frequency switching current from passing through to the input. Ceramic capacitors with X5R or X7R dielectrics are recommended for their low ESR and small temperature coefficients. For most applications, a 4.7 μ F ceramic capacitor is sufficient.

Selecting the Inductor

The MP3366 requires an inductor to supply a higher output voltage while being driven by the input voltage. A larger value inductor results in less ripple current, a lower peak inductor current, and less stress on the internal N-channel MOSFET. However, a larger value inductor also has a larger physical size, higher series resistance, and lower saturation current.

Choose an inductor that does not saturate under worst-case load conditions. Select the minimum inductor value to ensure that the boost converter works in continuous conduction mode with high efficiency and good EMI performance.

Calculate the required inductance value using Equation (2) and Equation (3):

$$L \geq \frac{\eta \times V_{OUT} \times D \times (1-D)^2}{2 \times f_{SW} \times I_{LOAD}} \quad (2)$$

$$D = 1 - \frac{V_{IN}}{V_{OUT}} \quad (3)$$

Where V_{IN} and V_{OUT} are the input and output voltages, f_{SW} is the switching frequency, I_{LOAD} is the LED load current, and η is the efficiency.

With a given inductor value, the inductor DC current rating is at least 40% higher than the maximum input peak inductor current for most applications. The inductor's DC resistance should be as small as possible to achieve higher efficiency.

Selecting the Output Capacitor

The output capacitor keeps the output voltage ripple small and ensures feedback loop stability. The output capacitor impedance must be low at the switching frequency. Ceramic capacitors with X7R dielectrics are recommended for their low ESR characteristics. For most applications, a 2.2 μ F ceramic capacitor is sufficient.

Setting the Over-Voltage Protection (OVP)

The open string protection is achieved through the detection of the voltage on OVP. In some unexpected cases, the part continues boosting the output voltage higher and higher. If the output voltage reaches the programmed OVP threshold, the protection is triggered.

To ensure that the chip functions properly, select the resistor values for the OVP resistor divider to provide an appropriate set voltage. The recommended OVP point is about 1.1 to 1.2 times higher than the output voltage for normal operation. The OVP voltage can be calculated with Equation (4):

$$V_{OVP} = 1.2(V) \times \left(1 + \frac{R_{HIGH}}{R_{LOW}}\right) \quad (4)$$

PCB Layout Guidelines

Efficient PBC layout is critical for stable operation. Proper layout of the high frequency switching path can prevent noise and electromagnetic interference. For best results, follow the guidelines below.

1. Keep the loop of LX to PGND (U1), output diode (D1), and output capacitor as short as possible, since the loop is flowing with high frequency pulse current.
2. In order to reduce the noise affection, it is recommend to separate the power ground(PGND) and analog ground(AGND), then connect PGND and AGND together.

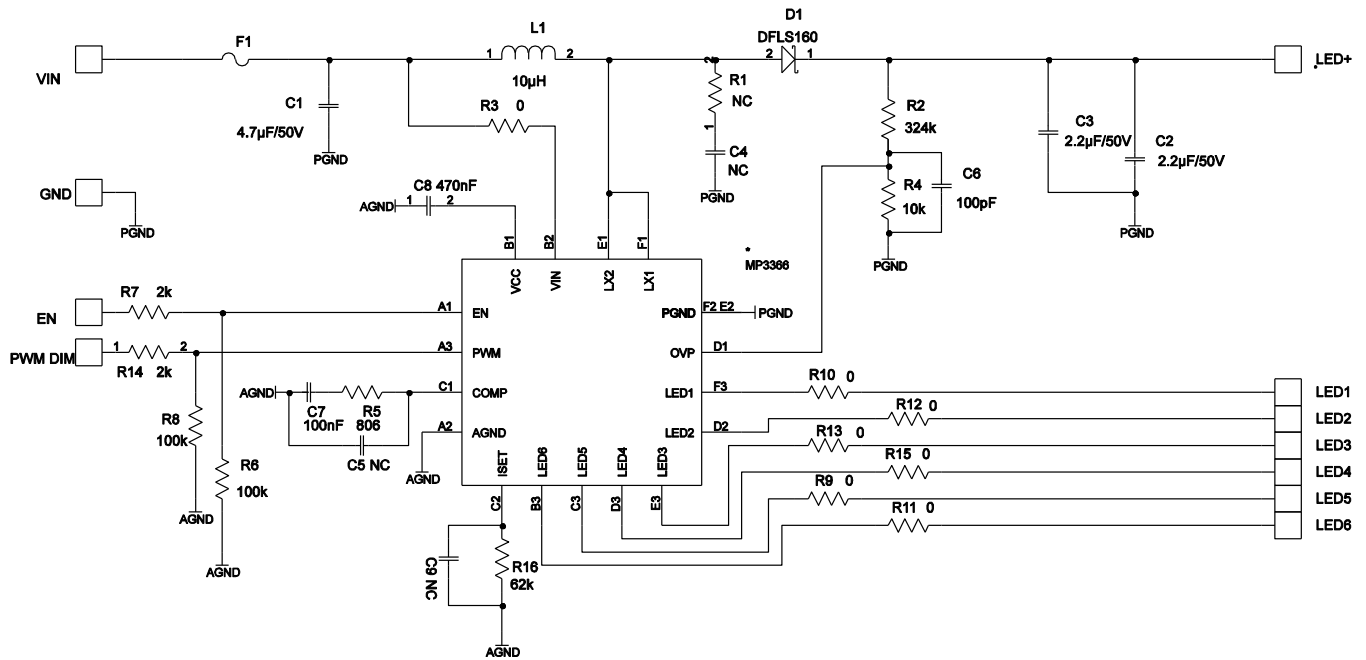
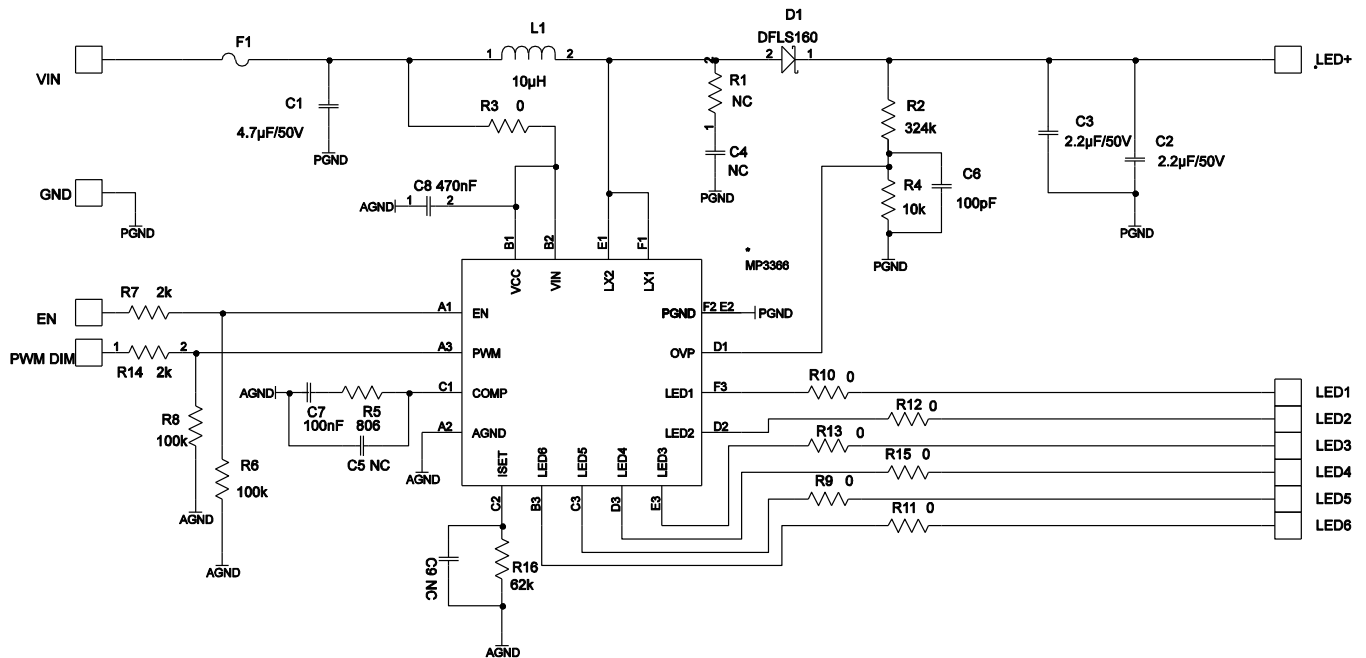
TYPICAL APPLICATION CIRCUITS

Figure 2: $V_{IN} > 5.5V$, 6-String, 20mA/String Application

Figure 3: $V_{IN} < 5.5V$, 6-String, 20mA/String Application

NOTE: Tie VIN and VCC together. Some components are reasonably adjustable based on real cases.

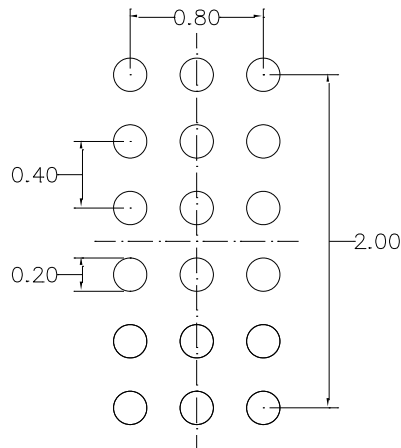
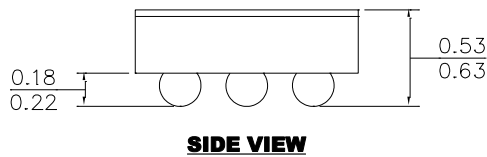
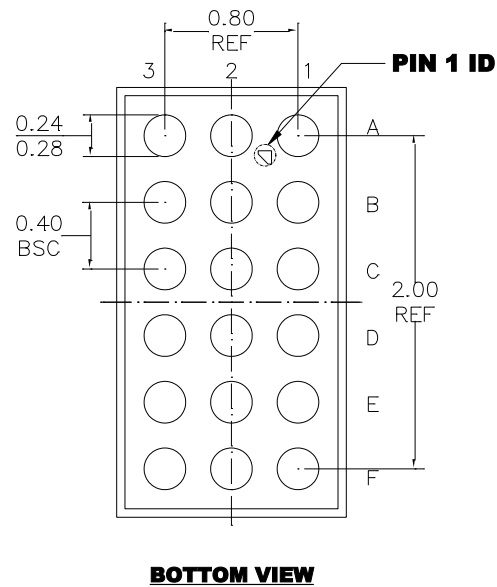
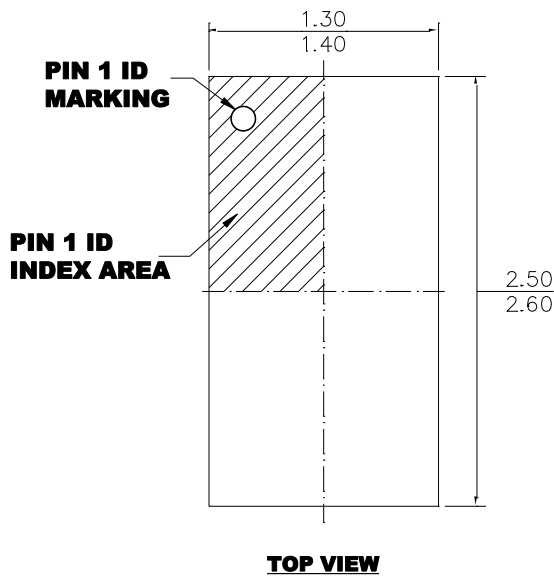
PACKAGE INFORMATION

WLCSP-18(1.35mmx2.55mm)



NOTE:

- 1) ALL DIMENSIONS ARE IN MILLIMETERS.
- 2) BALL COPLANARITY SHALL BE 0.05 MILLIMETER MAX.
- 3) JEDEC REFERENCE IS MO-211.
- 4) DRAWING IS NOT TO SCALE.

NOTICE: The information in this document is subject to change without notice. Please contact MPS for current specifications. Users should warrant and guarantee that third party Intellectual Property rights are not infringed upon when integrating MPS products into any application. MPS will not assume any legal responsibility for any said applications.