

## ISO782xLL High-Performance, 8000- $V_{PK}$ Reinforced Isolated Dual-LVDS Buffer

### 1 Features

- Complies with TIA/EIA-644-A LVDS Standard
- Signaling Rate: Up to 100 Mbps
- Wide Supply Range: 2.25 V to 5.5 V
- Wide Temperature Range:  $-55^{\circ}\text{C}$  to  $+125^{\circ}\text{C}$  Ambient
- Low Power Consumption, per Channel at 100 Mbps:
  - Typical 9.3-mA (ISO7820LL)
  - Typical 9.5-mA (ISO7821LL)
- Low Propagation Delay: 17-ns Typical
- Industry leading CMTI (min):  $\pm 100$  kV/ $\mu\text{s}$
- Robust Electromagnetic Compatibility (EMC)
- System-Level ESD, EFT, and Surge Immunity
- Low Emissions
- Isolation Barrier Life: > 40 Years
- Wide Body and Extra-Wide Body SOIC-16 Package Options
- Isolation Surge Withstand Voltage 12800  $V_{PK}$
- Safety-Related Certifications:
  - 8000- $V_{PK}$  Reinforced Isolation per DIN V VDE V 0884-10 (VDE V 0884-10):2006-12
  - 5700- $V_{RMS}$  Isolation for 1 minute per UL 1577
  - CSA Component Acceptance Notice 5A, IEC 60950-1 and IEC 60601-1 End Equipment Standards
  - TUV Certification per EN 61010-1 and EN 60950-1
  - GB4943.1-2011 CQC Certification
  - All Certifications are Planned

### 2 Applications

- Motor Control
- Test and Measurement
- Industrial Automation
- Medical Equipment
- Communication Systems

### 3 Description

The ISO782xLL family of devices is a high-performance, isolated dual-LVDS buffer with 8000- $V_{PK}$  isolation voltage. This device provides high electromagnetic immunity and low emissions at low-power consumption, while isolating the LVDS bus signal. Each isolation channel has an LVDS receive and transmit buffer separated by silicon dioxide ( $\text{SiO}_2$ ) insulation barrier.

The ISO7820LL device has two forward-direction channels. The ISO7821LL device has one forward and one reverse-direction channel.

Through innovative chip design and layout techniques, the electromagnetic compatibility of the ISO782xLL family of devices has been significantly enhanced to ease system-level ESD, EFT, surge, and emission compliance.

The ISO782xLL family of devices is available in 16-pin SOIC wide-body (DW) package and extra-wide body (DWW) packages.

#### Device Information<sup>(1)</sup>

PART NUMBER	PACKAGE	BODY SIZE (NOM)
ISO7820LL	DW (16)	10.30 mm × 7.50 mm
ISO7821LL	DWW (16)	10.30 mm × 14.00 mm

(1) For all available packages, see the orderable addendum at the end of the data sheet.

#### Simplified Schematic

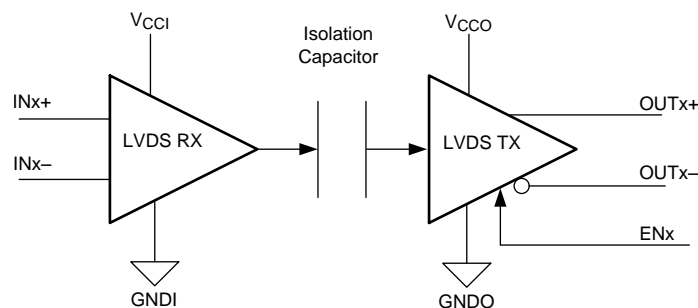

Copyright © 2016, Texas Instruments Incorporated

$V_{CCI}$  and  $GNDI$  are supply and ground connections respectively for the input channels.

$V_{CCO}$  and  $GNDO$  are supply and ground connections respectively for the output channels.



## Table of Contents

<b>1 Features</b> .....	<b>1</b>	<b>8 Detailed Description</b> .....	<b>19</b>
<b>2 Applications</b> .....	<b>1</b>	8.1 Overview .....	19
<b>3 Description</b> .....	<b>1</b>	8.2 Functional Block Diagram .....	19
<b>4 Revision History</b> .....	<b>2</b>	8.3 Feature Description .....	19
<b>5 Pin Configuration and Functions</b> .....	<b>3</b>	8.4 Device Functional Modes .....	20
<b>6 Specifications</b> .....	<b>4</b>	<b>9 Application and Implementation</b> .....	<b>21</b>
6.1 Absolute Maximum Ratings .....	4	9.1 Application Information .....	21
6.2 ESD Ratings .....	4	9.2 Typical Application .....	21
6.3 Recommended Operating Conditions .....	4	<b>10 Power Supply Recommendations</b> .....	<b>25</b>
6.4 Thermal Information .....	5	<b>11 Layout</b> .....	<b>26</b>
6.5 Power Ratings .....	5	11.1 Layout Guidelines .....	26
6.6 Insulation Specifications .....	6	11.2 Layout Example .....	26
6.7 Safety-Related Certifications .....	7	<b>12 Device and Documentation Support</b> .....	<b>27</b>
6.8 Safety Limiting Values .....	7	12.1 Documentation Support .....	27
6.9 DC Electrical Characteristics .....	8	12.2 Receiving Notification of Documentation Updates .....	27
6.10 DC Supply Current Characteristics .....	9	12.3 Community Resources .....	27
6.11 Switching Characteristics .....	11	12.4 Trademarks .....	27
6.12 Insulation Characteristics Curves .....	12	12.5 Electrostatic Discharge Caution .....	27
6.13 Typical Characteristics .....	13	12.6 Glossary .....	27
<b>7 Parameter Measurement Information</b> .....	<b>16</b>	<b>13 Mechanical, Packaging, and Orderable Information</b> .....	<b>27</b>

## 4 Revision History

NOTE: Page numbers for previous revisions may differ from page numbers in the current version.

### Changes from Original (March 2016) to Revision A

Page

- Changed the device status from *Product Preview* to *Production Data* and released full version of the data sheet..... 1

## 5 Pin Configuration and Functions

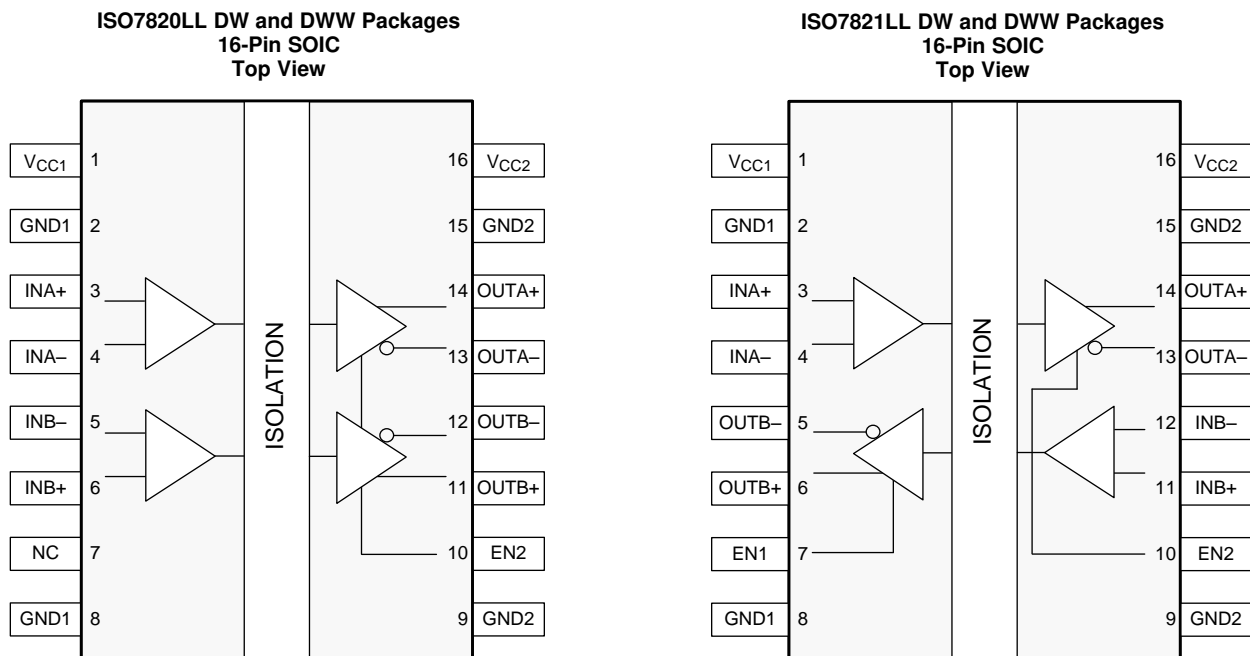

### Pin Functions

NAME	PIN NO.		I/O	DESCRIPTION
	ISO7820LL	ISO7821LL		
EN1	—	7	I	Output enable 1. Output pins on side 1 are enabled when EN1 is high or open and in high impedance state when EN1 is low.
EN2	10	10	I	Output enable 2. Output pins on side 2 are enabled when EN2 is high or open and in high impedance state when EN2 is low.
GND1	2	2	—	Ground connection for $V_{CC1}$
	8	8		
GND2	9	9	—	Ground connection for $V_{CC2}$
	15	15		
INA+	3	3	I	Positive differential input, channel A
INA-	4	4	I	Negative differential input, channel A
INB+	6	11	I	Positive differential input, channel B
INB-	5	12	I	Negative differential input, channel B
NC	7	—	—	Not connected
OUTA+	14	14	O	Positive differential output, channel A
OUTA-	13	13	O	Negative differential output, channel A
OUTB+	11	6	O	Positive differential output, channel B
OUTB-	12	5	O	Negative differential output, channel B
$V_{CC1}$	1	1	—	Power supply, side 1, $V_{CC1}$
$V_{CC2}$	16	16	—	Power supply, side 2, $V_{CC2}$

## 6 Specifications

### 6.1 Absolute Maximum Ratings

over operating free-air temperature range (unless otherwise noted)<sup>(1)</sup>

			MIN	MAX	UNIT
$V_{CCx}$	Supply voltage <sup>(2)</sup>	$V_{CC1}, V_{CC2}$	-0.5	6	V
V	Voltage on input, output, and enable pins	OUTx, INx, ENx	-0.5	$V_{CCx} + 0.5^{(3)}$	V
$I_O$	Maximum current through OUTx pins		-20	20	mA
$T_J$	Junction temperature		-55	150	°C
$T_{stg}$	Storage temperature		-65	150	°C

- (1) Stresses beyond those listed under *Absolute Maximum Ratings* may cause permanent damage to the device. These are stress ratings only, which do not imply functional operation of the device at these or any other conditions beyond those indicated under *Recommended Operating Conditions*. Exposure to absolute-maximum-rated conditions for extended periods may affect device reliability.
- (2) All voltage values except differential I/O bus voltages are with respect to the local ground terminal (GND1 or GND2) and are peak voltage values.
- (3) Maximum voltage must not exceed 6 V.

### 6.2 ESD Ratings

			VALUE	UNIT
$V_{(ESD)}$	Electrostatic discharge	Human-body model (HBM), per ANSI/ESDA/JEDEC JS-001 <sup>(1)</sup>	±4500	V
		Charged-device model (CDM), per JEDEC specification JESD22-C101 <sup>(2)</sup>	±1500	

- (1) JEDEC document JEP155 states that 500-V HBM allows safe manufacturing with a standard ESD control process.
- (2) JEDEC document JEP157 states that 250-V CDM allows safe manufacturing with a standard ESD control process.

### 6.3 Recommended Operating Conditions

			MIN	NOM	MAX	UNIT
$V_{CC1}, V_{CC2}$	Supply voltage		2.25	3.3	5.5	V
$ V_{ID} $	Magnitude of RX input differential voltage	Driven with voltage sources on RX pins	100		600	mV
$V_{IC}$	RX input common-mode voltage	$V_{CC1}, V_{CC2} \geq 3\text{ V}$	$0.5  V_{ID} $		$2.4 - 0.5  V_{ID} $	V
		$V_{CC1}, V_{CC2} < 3\text{ V}$	$0.5  V_{ID} $		$V_{CCx} - 0.6 - 0.5  V_{ID} $	V
$R_L$	TX far end differential termination			100		$\Omega$
DR	Signaling rate		0		100	Mbps
$T_A$	Ambient temperature		-55	25	125	°C

## 6.4 Thermal Information

THERMAL METRIC <sup>(1)</sup>		ISO7820LL ISO7821LL		UNIT
		DW (SOIC)	DWW (SOIC)	
		16 PINS	16 PINS	
$R_{\theta JA}$	Junction-to-ambient thermal resistance	82	84.6	°C/W
$R_{\theta JC(top)}$	Junction-to-case(top) thermal resistance	44.6	46.4	°C/W
$R_{\theta JB}$	Junction-to-board thermal resistance	46.6	55.3	°C/W
$\Psi_{JT}$	Junction-to-top characterization parameter	17.8	18.7	°C/W
$\Psi_{JB}$	Junction-to-board characterization parameter	46.1	54.5	°C/W
$R_{\theta JC(bottom)}$	Junction-to-case(bottom) thermal resistance	—	—	°C/W

(1) For more information about traditional and new thermal metrics, see the [Semiconductor and IC Package Thermal Metrics](#) application report.

## 6.5 Power Ratings

$V_{CC1} = V_{CC2} = 5.5$  V,  $T_J = 150^\circ\text{C}$ ,  $C_L = 5$  pF, input a 50-MHz 50% duty-cycle square wave,  $EN1 = EN2 = 5.5$  V,  $R_L = 100\text{-}\Omega$  differential

PARAMETER		TEST CONDITIONS	MIN	TYP	MAX	UNIT
<b>ISO7821LL</b>						
$P_D$	Maximum power dissipation (both sides)				156	mW
$P_{D1}$	Maximum power dissipation (side 1)				78	mW
$P_{D2}$	Maximum power dissipation (side 2)				78	mW
<b>ISO7820LL</b>						
$P_D$	Maximum power dissipation (both sides)				152	mW
$P_{D1}$	Maximum power dissipation (side 1)				36	mW
$P_{D2}$	Maximum power dissipation (side 2)				116	mW

## 6.6 Insulation Specifications

 over operating free-air temperature range (unless otherwise noted)<sup>(1)</sup>

PARAMETER		TEST CONDITIONS	SPECIFICATION		UNIT
			DW	DWW	
<b>GENERAL</b>					
CLR	External clearance <sup>(1)</sup>	Shortest terminal-to-terminal distance through air	>8	>14.5	mm
CPG	External creepage <sup>(1)</sup>	Shortest terminal-to-terminal distance across the package surface	>8	>14.5	mm
DTI	Distance through the insulation	Minimum internal gap (internal clearance)	>21	>21	μm
CTI	Tracking resistance (comparative tracking index)	DIN EN 60112 (VDE 0303–11); IEC 60112; UL 746A	>600	>600	V
	Material group	According to IEC 60664-1	I	I	
	Overvoltage category per IEC 60664-1	Rated mains voltage ≤ 600 V <sub>RMS</sub>	I–IV	I–IV	
		Rated mains voltage ≤ 1000 V <sub>RMS</sub>	I–III	I–IV	
<b>DIN V VDE V 0884–10 (VDE V 0884–10):2006–12<sup>(2)</sup></b>					
V <sub>IORM</sub>	Maximum repetitive peak isolation voltage	AC voltage (bipolar)	2121	2828	V <sub>PK</sub>
V <sub>IOWM</sub>	Maximum isolation working voltage	AC voltage (sine wave); time dependent dielectric breakdown (TDDb) test; see <a href="#">Figure 1</a> and <a href="#">Figure 2</a>	1500	2000	V <sub>RMS</sub>
		DC voltage	2121	2828	V <sub>DC</sub>
V <sub>IOTM</sub>	Maximum transient isolation voltage	V <sub>TEST</sub> = V <sub>IOTM</sub> t = 60 s (qualification) t = 1 s (100% production)	8000	8000	V <sub>PK</sub>
V <sub>IOSM</sub>	Maximum surge isolation voltage <sup>(3)</sup>	Test method per IEC 60065, 1.2/50 μs waveform, V <sub>TEST</sub> = 1.6 × V <sub>IOSM</sub> = 12800 V <sub>PK</sub> (qualification)	8000	8000	V <sub>PK</sub>
q <sub>pd</sub>	Apparent charge <sup>(4)</sup>	Method a: After I/O safety test subgroup 2/3, V <sub>ini</sub> = V <sub>IOTM</sub> , t <sub>ini</sub> = 60 s; V <sub>pd(m)</sub> = 1.2 × V <sub>IORM</sub> = 2545 V <sub>PK</sub> (DW) and 3394 V <sub>PK</sub> (DWW), t <sub>m</sub> = 10 s	≤5	≤5	pC
		Method a: After environmental tests subgroup 1, V <sub>ini</sub> = V <sub>IOTM</sub> , t <sub>ini</sub> = 60 s; V <sub>pd(m)</sub> = 1.6 × V <sub>IORM</sub> = 3394 V <sub>PK</sub> (DW) and 4525 V <sub>PK</sub> (DWW), t <sub>m</sub> = 10 s	≤5	≤5	
		Method b1: At routine test (100% production) and preconditioning (type test) V <sub>ini</sub> = V <sub>IORM</sub> , t <sub>ini</sub> = 1 s; V <sub>pd(m)</sub> = 1.875 × V <sub>IORM</sub> = 3977 V <sub>PK</sub> (DW) and 5303 V <sub>PK</sub> (DWW), t <sub>m</sub> = 1 s	≤5	≤5	
C <sub>IO</sub>	Barrier capacitance, input to output <sup>(5)</sup>	V <sub>IO</sub> = 0.4 × sin(2πft), f = 1 MHz	~0.7	~0.7	pF
R <sub>IO</sub>	Isolation resistance, input to output <sup>(5)</sup>	V <sub>IO</sub> = 500 V, T <sub>A</sub> = 25°C	>10 <sup>12</sup>	>10 <sup>12</sup>	Ω
		V <sub>IO</sub> = 500 V, 100°C ≤ T <sub>A</sub> ≤ 125°C	>10 <sup>11</sup>	>10 <sup>11</sup>	
		V <sub>IO</sub> = 500 V at T <sub>S</sub> = 150°C	>10 <sup>9</sup>	>10 <sup>9</sup>	
	Pollution degree		2	2	
	Climatic category		55/125/21	55/125/21	
<b>UL 1577</b>					
V <sub>ISO</sub>	Withstanding isolation voltage	V <sub>TEST</sub> = V <sub>ISO</sub> = 5700 V <sub>RMS</sub> , t = 60 s (qualification); V <sub>TEST</sub> = 1.2 × V <sub>ISO</sub> = 6840 V <sub>RMS</sub> , t = 1 s (100% production)	5700	5700	V <sub>RMS</sub>

- (1) Creepage and clearance requirements should be applied according to the specific equipment isolation standards of an application. Care should be taken to maintain the creepage and clearance distance of a board design to ensure that the mounting pads of the isolator on the printed-circuit board do not reduce this distance. Creepage and clearance on a printed-circuit board become equal in certain cases. Techniques such as inserting grooves and/or ribs on a printed circuit board are used to help increase these specifications.
- (2) This coupler is suitable for *safe electrical insulation* only within the safety ratings. Compliance with the safety ratings shall be ensured by means of suitable protective circuits.
- (3) Testing is carried out in air or oil to determine the intrinsic surge immunity of the isolation barrier.
- (4) Apparent charge is electrical discharge caused by a partial discharge (pd).
- (5) All pins on each side of the barrier tied together creating a two-terminal device.

## 6.7 Safety-Related Certifications

VDE	CSA	UL	CQC	TUV
Plan to certify according to DIN V VDE V 0884-10 (VDE V 0884-10):2006-12 and DIN EN 60950-1 (VDE 0805 Teil 1):2011-01	Plan to certify under CSA Component Acceptance Notice 5A, IEC 60950-1 and IEC 60601-1	Plan to certify according to UL 1577 Component Recognition Program	Plan to certify according to GB 4943.1-2011	Plan to certify according to EN 61010-1:2010 (3rd Ed) and EN 60950-1:2006/A11:2009/A1:2010/A12:2011/A2:2013
Reinforced insulation Maximum transient isolation voltage, 8000 V <sub>PK</sub> ; Maximum repetitive peak isolation voltage, 2121 V <sub>PK</sub> (DW), 2828 V <sub>PK</sub> (DWW); Maximum surge isolation voltage, 8000 V <sub>PK</sub>	Reinforced insulation per CSA 60950-1-07+A1+A2 and IEC 60950-1 2nd Ed., 800 V <sub>RMS</sub> (DW package) and 1450 V <sub>RMS</sub> (DWW package) max working voltage (pollution degree 2, material group I); 2 MOPP (Means of Patient Protection) per CSA 60601-1:14 and IEC 60601-1 Ed. 3.1, 250 V <sub>RMS</sub> (354 V <sub>PK</sub> ) max working voltage (DW package)	Single protection, 5700 V <sub>RMS</sub>	Reinforced Insulation, Altitude ≤ 5000 m, Tropical Climate, 250 V <sub>RMS</sub> maximum working voltage	5700 V <sub>RMS</sub> Reinforced insulation per EN 61010-1:2010 (3rd Ed) up to working voltage of 600 V <sub>RMS</sub> (DW package) and 1000 V <sub>RMS</sub> (DWW package)  5700 V <sub>RMS</sub> Reinforced insulation per EN 60950-1:2006/A11:2009/A1:2010/A12:2011/A2:2013 up to working voltage of 800 V <sub>RMS</sub> (DW package) and 1450 V <sub>RMS</sub> (DWW package)
Certification planned	Certification planned	Certification planned	Certification planned	Certification planned

## 6.8 Safety Limiting Values

Safety limiting intends to minimize potential damage to the isolation barrier upon failure of input or output circuitry. A failure of the I/O can allow low resistance to ground or the supply and, without current limiting, dissipate sufficient power to overheat the die and damage the isolation barrier potentially leading to secondary system failures.

PARAMETER		TEST CONDITIONS	MIN	TYP	MAX	UNIT
<b>DW PACKAGE</b>						
I <sub>S</sub>	Safety input, output, or supply current	R <sub>θJA</sub> = 82°C/W, V <sub>I</sub> = 5.5 V, T <sub>J</sub> = 150°C, T <sub>A</sub> = 25°C, see <a href="#">Figure 3</a>			277	mA
		R <sub>θJA</sub> = 82°C/W, V <sub>I</sub> = 3.6 V, T <sub>J</sub> = 150°C, T <sub>A</sub> = 25°C, see <a href="#">Figure 3</a>			423	
		R <sub>θJA</sub> = 82°C/W, V <sub>I</sub> = 2.75 V, T <sub>J</sub> = 150°C, T <sub>A</sub> = 25°C, see <a href="#">Figure 3</a>			554	
P <sub>S</sub>	Safety input, output, or total power	R <sub>θJA</sub> = 82°C/W, T <sub>J</sub> = 150°C, T <sub>A</sub> = 25°C, see <a href="#">Figure 5</a>			1524	mW
T <sub>S</sub>	Maximum safety temperature				150	°C
<b>DWW PACKAGE</b>						
I <sub>S</sub>	Safety input, output, or supply current	R <sub>θJA</sub> = 84.6°C/W, V <sub>I</sub> = 5.5 V, T <sub>J</sub> = 150°C, T <sub>A</sub> = 25°C, see <a href="#">Figure 4</a>			269	mA
		R <sub>θJA</sub> = 84.6°C/W, V <sub>I</sub> = 3.6 V, T <sub>J</sub> = 150°C, T <sub>A</sub> = 25°C, see <a href="#">Figure 4</a>			410	
		R <sub>θJA</sub> = 84.6°C/W, V <sub>I</sub> = 2.75 V, T <sub>J</sub> = 150°C, T <sub>A</sub> = 25°C, see <a href="#">Figure 4</a>			537	
P <sub>S</sub>	Safety input, output, or total power	R <sub>θJA</sub> = 84.6°C/W, T <sub>J</sub> = 150°C, T <sub>A</sub> = 25°C, see <a href="#">Figure 6</a>			1478	mW
T <sub>S</sub>	Maximum safety temperature				150	°C

The maximum safety temperature is the maximum junction temperature specified for the device. The power dissipation and junction-to-air thermal impedance of the device installed in the application hardware determines the junction temperature. The assumed junction-to-air thermal resistance in the [Thermal Information](#) is that of a device installed on a High-K test board for leaded surface-mount packages. The power is the recommended maximum input voltage times the current. The junction temperature is then the ambient temperature plus the power times the junction-to-air thermal resistance.

## 6.9 DC Electrical Characteristics

(over recommended operating conditions unless otherwise noted)

PARAMETER		TEST CONDITIONS	MIN	TYP	MAX	UNIT
$I_{IN(EN)}$	Leakage Current on ENx pins	Internal pullup on ENx pins		13	40	$\mu\text{A}$
$V_{CC+(UVLO)}$	Positive-going undervoltage-lockout (UVLO) threshold				2.25	V
$V_{CC-(UVLO)}$	Negative-going UVLO threshold		1.7			V
$V_{HYS(UVLO)}$	UVLO threshold hysteresis			0.2		V
$V_{EN(ON)}$	EN pin turn-on threshold				$0.7 V_{CCx}$	V
$V_{EN(OFF)}$	EN pin turn-off threshold		$0.3 V_{CCx}$			V
$V_{EN(HYS)}$	EN pin threshold hysteresis			$0.1 V_{CCx}$		V
CMTI	Common-mode transient immunity	$V_I = V_{CCI}^{(1)}$ or 0 V; $V_{CM} = 1000$ V; see Figure 25	100	120		kV/ $\mu\text{s}$
<b>LVDS TX</b>						
$ V_{OD} $	TX DC output differential voltage	$R_L = 100 \Omega$ , See Figure 26	250	350	450	mV
$\Delta V_{OD}$	Change in TX DC output differential between logic 1 and 0 states	$R_L = 100 \Omega$ , see Figure 26	-10	0	10	mV
$V_{OC}$	TX DC output common mode voltage	$R_L = 100 \Omega$ , see Figure 26	1.125	1.2	1.375	V
$\Delta V_{OC}$	TX DC common mode voltage difference	$R_L = 100 \Omega$ , see Figure 26	-25	0	25	mV
$I_{OS}$	TX output short circuit current through OUTx	OUTx = 0			10	mA
		OUTxP = OUTxM			10	
$I_{OZ}$	TX output current when in high impedance	ENx = 0, OUTx from 0 to $V_{CC}$	-5		5	$\mu\text{A}$
$C_{OUT}$	TX output pad capacitance on OUTx at 1 MHz	DW package: ENx = 0, DC offset = $V_{CC} / 2$ , Swing = 200 mV, f = 1 MHz		10		pF
		DWW package: ENx = 0, DC offset = $V_{CC} / 2$ , Swing = 200 mV, f = 1 MHz		10		
<b>LVDS RX</b>						
$V_{IC}$	RX input common mode voltage	$V_{CC1}, V_{CC2} \geq 3$ V	$0.5  V_{ID} $	1.2	$2.4 - 0.5  V_{ID} $	V
		$V_{CC1}, V_{CC2} < 3$ V	$0.5  V_{ID} $	1.2	$V_{CCx} - 0.6 - 0.5  V_{ID} $	
$V_{IT1}$	Positive going RX input differential threshold	Across $V_{IC}$			50	mV
$V_{IT2}$	Negative going RX input differential threshold	Across $V_{IC}$	-50			mV
$I_{INx}$	Input current on INx	From 0 to $V_{CCx}$ (each input independently)		10	20	$\mu\text{A}$
$I_{INxP} - I_{INxM}$	Input current balance	From 0 to $V_{CCx}$	-6		6	$\mu\text{A}$
$C_{IN}$	RX input pad capacitance on INx at 1 MHz	DW package: DC offset = 1.2 V, Swing = 200 mV, f = 1 MHz		6.6		pF
		DWW package: DC offset = 1.2 V, Swing = 200 mV, f = 1 MHz		7.5		

 (1)  $V_{CCI}$  = Input-side  $V_{CCx}$ ;  $V_{CCO}$  = Output-side  $V_{CCx}$ .



## 6.10 DC Supply Current Characteristics

(over recommended operating conditions unless otherwise noted)

PARAMETER		TEST CONDITIONS	MIN	TYP	MAX	UNIT
<b>ISO7821LL</b>						
$I_{CC1}$ Supply current side 1 and side 2 $I_{CC2}$	$2.25\text{ V} < V_{CC1},$ $V_{CC2} < 3.6\text{ V}$	EN1 = EN2 = 0, OUTx floating, $V_{ID} \geq 50\text{ mV}$	2.2	3.3		mA
		EN1 = EN2 = 0, OUTx floating, $V_{ID} \leq -50\text{ mV}$	3.4	5.1		
		EN1 = EN2 = 1, $R_L = 100\text{-}\Omega$ differential, $V_{ID} \geq 50\text{ mV}$	6.1	9.2		
		EN1 = EN2 = 1, $R_L = 100\text{-}\Omega$ differential, $V_{ID} \leq -50\text{ mV}$	7.4	11.1		
		EN1 = EN2 = 1, $R_L = 100\text{-}\Omega$ differential, data communication at 1 Mbps	6.7	10.2		
		EN1 = EN2 = 1, $R_L = 100\text{-}\Omega$ differential, data communication at 50 Mbps	7.4	11.5		
		EN1 = EN2 = 1, $R_L = 100\text{-}\Omega$ differential, data communication at 100 Mbps	8.3	12.5		
	$4.5\text{ V} < V_{CC1},$ $V_{CC2} < 5.5\text{ V}$	EN1 = EN2 = 0, OUTx floating, $V_{ID} \geq 50\text{ mV}$	2.2	3.4		
		EN1 = EN2 = 0, OUTx floating, $V_{ID} \leq -50\text{ mV}$	3.5	5.2		
		EN1 = EN2 = 1, $R_L = 100\text{-}\Omega$ differential, $V_{ID} \geq 50\text{ mV}$	6.4	9.8		
		EN1 = EN2 = 1, $R_L = 100\text{-}\Omega$ differential, $V_{ID} \leq -50\text{ mV}$	7.8	11.7		
		EN1 = EN2 = 1, $R_L = 100\text{-}\Omega$ differential, data communication at 1 Mbps	7.1	10.8		
		EN1 = EN2 = 1, $R_L = 100\text{-}\Omega$ differential, data communication at 50 Mbps	8.1	12.1		
		EN1 = EN2 = 1, $R_L = 100\text{-}\Omega$ differential, data communication at 100 Mbps	9.5	14.1		
<b>ISO7820LL</b>						
$I_{CC1}$ Supply current side 1	$2.25\text{ V} < V_{CC1},$ $V_{CC2} < 3.6\text{ V}$	EN1 = EN2 = 0, OUTx floating, $V_{ID} \geq 50\text{ mV}$	2.7	4.3		mA
		EN1 = EN2 = 0, OUTx floating, $V_{ID} \leq -50\text{ mV}$	5.3	7.9		
		EN1 = EN2 = 1, $R_L = 100\text{-}\Omega$ differential, $V_{ID} \geq 50\text{ mV}$	2.7	4.2		
		EN1 = EN2 = 1, $R_L = 100\text{-}\Omega$ differential, $V_{ID} \leq -50\text{ mV}$	5.2	8		
		EN1 = EN2 = 1, $R_L = 100\text{-}\Omega$ differential, data communication at 1 Mbps	4	6.1		
		EN1 = EN2 = 1, $R_L = 100\text{-}\Omega$ differential, data communication at 50 Mbps	4.1	6.2		
		EN1 = EN2 = 1, $R_L = 100\text{-}\Omega$ differential, data communication at 100 Mbps	4.3	6.4		
	$4.5\text{ V} < V_{CC1},$ $V_{CC2} < 5.5\text{ V}$	EN1 = EN2 = 0, OUTx floating, $V_{ID} \geq 50\text{ mV}$	2.8	4.4		
		EN1 = EN2 = 0, OUTx floating, $V_{ID} \leq -50\text{ mV}$	5.5	8.2		
		EN1 = EN2 = 1, $R_L = 100\text{-}\Omega$ differential, $V_{ID} \geq 50\text{ mV}$	2.9	4.5		
		EN1 = EN2 = 1, $R_L = 100\text{-}\Omega$ differential, $V_{ID} \leq -50\text{ mV}$	5.5	8.2		
		EN1 = EN2 = 1, $R_L = 100\text{-}\Omega$ differential, data communication at 1 Mbps	4.2	6.3		
		EN1 = EN2 = 1, $R_L = 100\text{-}\Omega$ differential, data communication at 50 Mbps	4.3	6.4		
		EN1 = EN2 = 1, $R_L = 100\text{-}\Omega$ differential, data communication at 100 Mbps	4.5	6.6		

**DC Supply Current Characteristics (continued)**

(over recommended operating conditions unless otherwise noted)

PARAMETER		TEST CONDITIONS	MIN	TYP	MAX	UNIT		
<b>ISO7820LL (continued)</b>								
$I_{CC2}$	Supply current side 2	EN1 = EN2 = 0, OUTx floating, $V_{ID} \geq 50$ mV		1.1	1.7	mA		
		EN1 = EN2 = 0, OUTx floating, $V_{ID} \leq -50$ mV		1.1	1.7			
		$V_{ID} \geq 50$ mV		9.1	13.7			
		EN1 = EN2 = 1, $R_L = 100\text{-}\Omega$ differential, $V_{ID} \leq -50$ mV		9.2	13.9			
		EN1 = EN2 = 1, $R_L = 100\text{-}\Omega$ differential, data communication at 1 Mbps		9.2	13.8			
		EN1 = EN2 = 1, $R_L = 100\text{-}\Omega$ differential, data communication at 50 Mbps		10.3	15.5			
		EN1 = EN2 = 1, $R_L = 100\text{-}\Omega$ differential, data communication at 100 Mbps		12.1	17.9			
		$2.25\text{ V} < V_{CC1}, V_{CC2} < 3.6\text{ V}$						
		EN1 = EN2 = 0, OUTx floating, $V_{ID} \geq 50$ mV		1.2	1.8			
		EN1 = EN2 = 0, OUTx floating, $V_{ID} \leq -50$ mV		1.2	1.8			
		EN1 = EN2 = 1, $R_L = 100\text{-}\Omega$ differential, $V_{ID} \geq 50$ mV		9.7	14.7			
		EN1 = EN2 = 1, $R_L = 100\text{-}\Omega$ differential, $V_{ID} \leq -50$ mV		9.7	14.8			
		EN1 = EN2 = 1, $R_L = 100\text{-}\Omega$ differential, data communication at 1 Mbps		9.7	14.7			
		EN1 = EN2 = 1, $R_L = 100\text{-}\Omega$ differential, data communication at 50 Mbps		11.5	17.3			
EN1 = EN2 = 1, $R_L = 100\text{-}\Omega$ differential, data communication at 100 Mbps		14.2	21					
$4.5\text{ V} < V_{CC1}, V_{CC2} < 5.5\text{ V}$								

## 6.11 Switching Characteristics

(over recommended operating conditions unless otherwise noted)

PARAMETER		TEST CONDITIONS	MIN	TYP	MAX	UNIT
<b>LVDS CHANNEL</b>						
$t_{PLH}$ $t_{PHL}$	Propagation delay time			17	25	ns
PWD	Pulse width distortion $ t_{PHL} - t_{PLH} $			0	4.5	ns
$t_{sk(o)}$	Channel-to-channel output skew time	Same directional channels, same voltage and temperature			2.5	ns
$t_{sk(pp)}$	Part-part skew	Same directional channels, same voltage and temperature			4.5	ns
$t_{CMset}$	Common-mode settling time after EN = 0 to EN = 1 transition.	Common-mode capacitive load = 100 pF to 0.5 nF			20	$\mu$ s
$t_{fs}$	Default output delay time from input power loss	Measured from the time $V_{CC}$ goes below 1.7 V, see <a href="#">Figure 24</a>		0.2	9	$\mu$ s
$t_{ie}$	Time interval error, or peak-to-peak jitter	$2^{16} - 1$ PRBS data at 100 Mbps; RX $V_{ID} = 350$ mV <sub>PP</sub> , 1 ns $t_{rf}$ 10% to 90%, $T_A = 25^\circ\text{C}$ , $V_{CC1}$ , $V_{CC2} = 3.3$ V		1		ns
<b>LVDS TX AND RX</b>						
$t_{rf}$	TX differential rise/fall times (20% to 80%)	See <a href="#">Figure 22</a>	300	780	1380	ps
$\Delta V_{OC(pp)}$	TX common-mode voltage peak-to-peak at 100 Mbps			0	150	mV <sub>PP</sub>
$t_{PLZ}$ , $t_{PHZ}$	TX disable time—valid output to HiZ	See <a href="#">Figure 23</a>		10	20	ns
$t_{PZH}$	Enable propagation delay, high impedance-to-high output	See <a href="#">Figure 23</a>		10	20	ns
$t_{PZL}$	Enable propagation delay, high impedance-to-low output	See <a href="#">Figure 23</a>		2	2.5	$\mu$ s
$ V_{ID} $	Magnitude of RX input differential voltage for valid operation	Driven with voltage sources on RX pins, see the figures in the <a href="#">Parameter Measurement Information</a> section	100		600	mV
$t_{rf(RX)}$	Allowed RX input differential rise and fall times (20% to 80%)	See <a href="#">Figure 27</a>		1	$0.3 \times UI^{(1)}$	ns

(1) UI is the unit interval.

### 6.12 Insulation Characteristics Curves

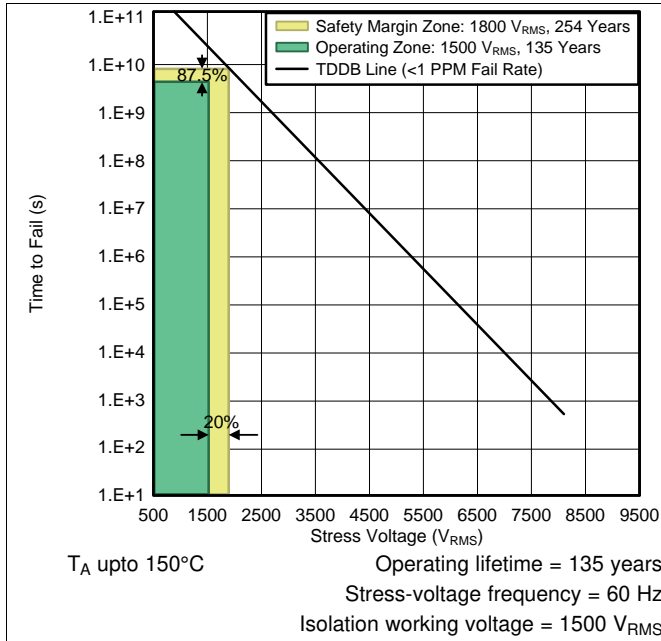

**Figure 1. Reinforced Isolation Capacitor Lifetime Projection for Devices in DW Package**

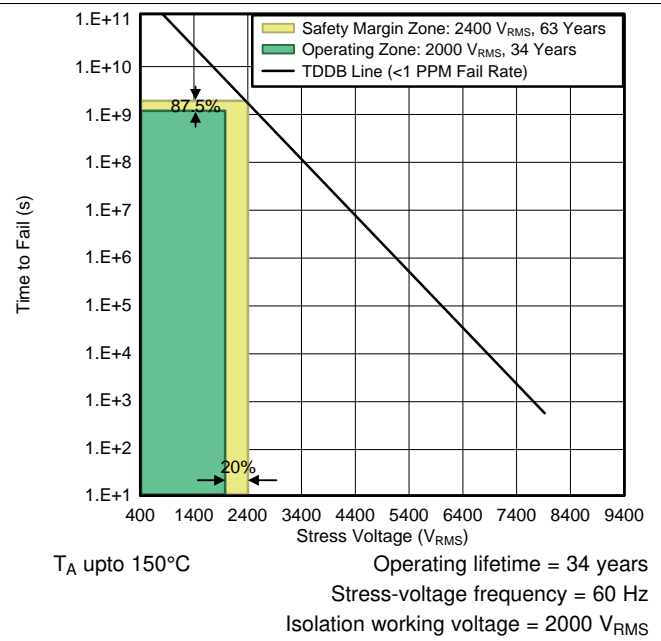

**Figure 2. Reinforced Isolation Capacitor Lifetime Projection for Devices in DWW Package**

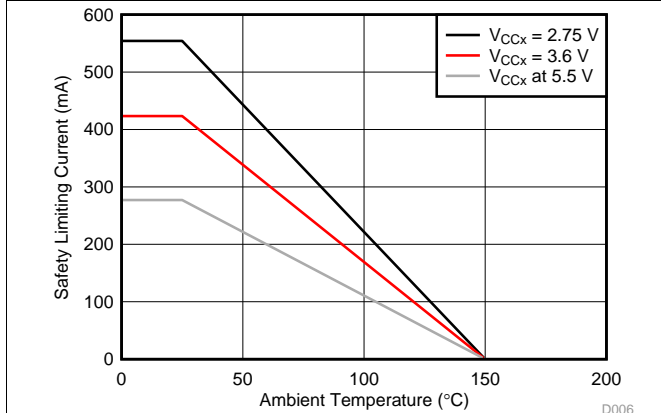

**Figure 3. Thermal Derating Curve for Limiting Current for DW Package**

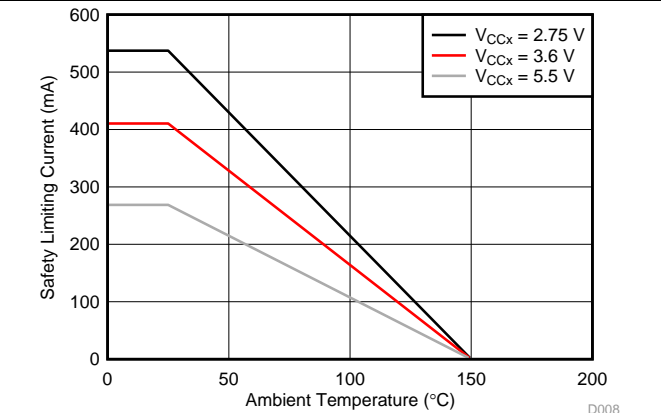

**Figure 4. Thermal Derating Curve for Limiting Current for DWW Package**

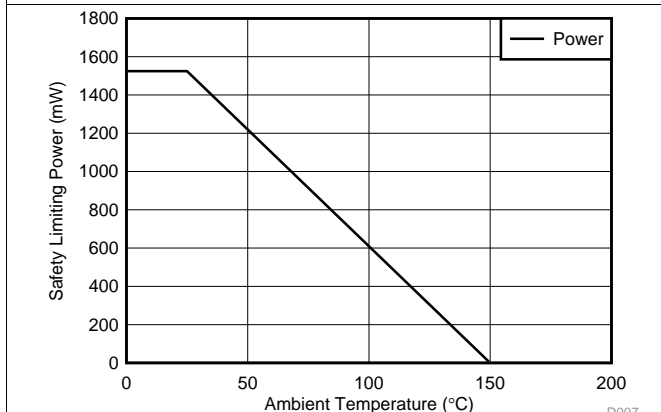

**Figure 5. Thermal Derating Curve for Limiting Power for DW Package**

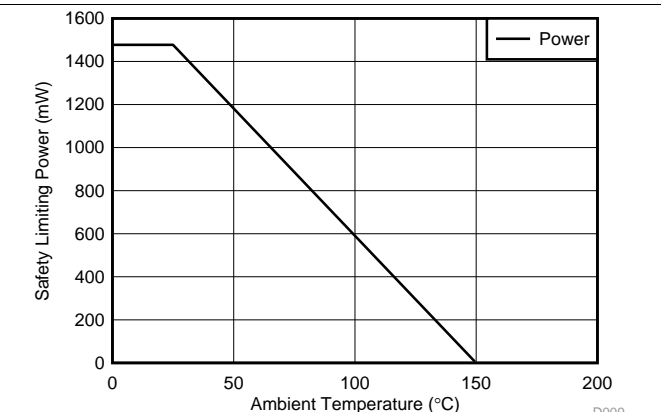

**Figure 6. Thermal Derating Curve for Limiting Power for DWW Package**

### 6.13 Typical Characteristics

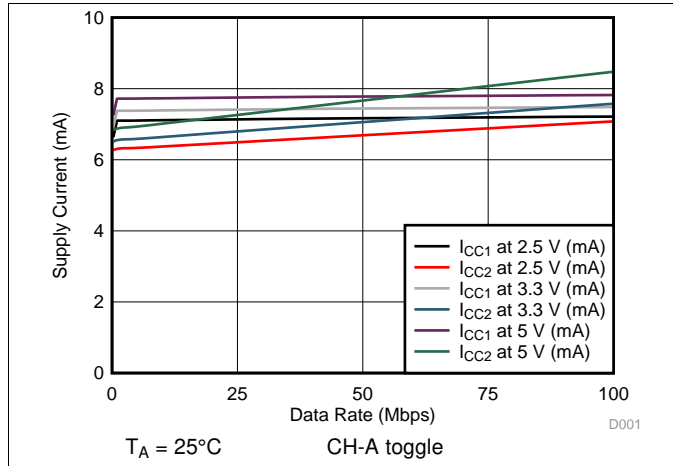

Figure 7. ISO7821LL Supply Current vs Data Rate (CH-A)

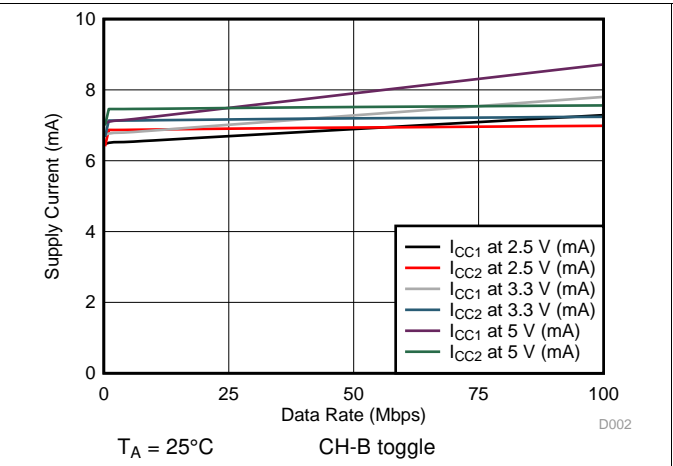

Figure 8. ISO7821LL Supply Current vs Data Rate (CH-B)

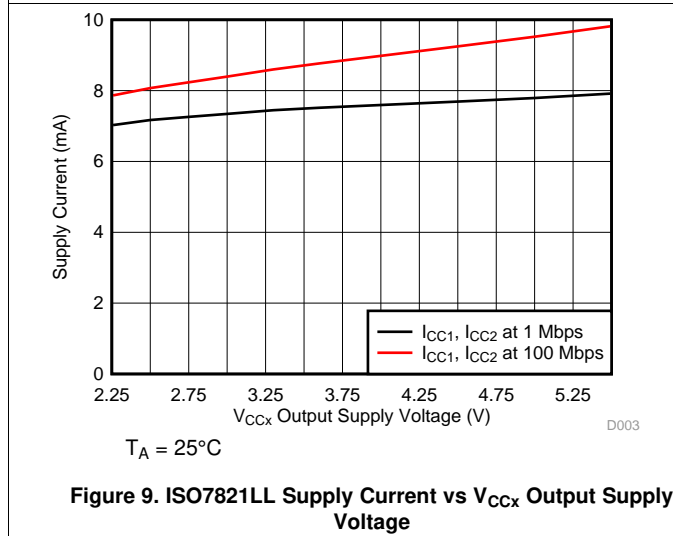

Figure 9. ISO7821LL Supply Current vs  $V_{CCX}$  Output Supply Voltage

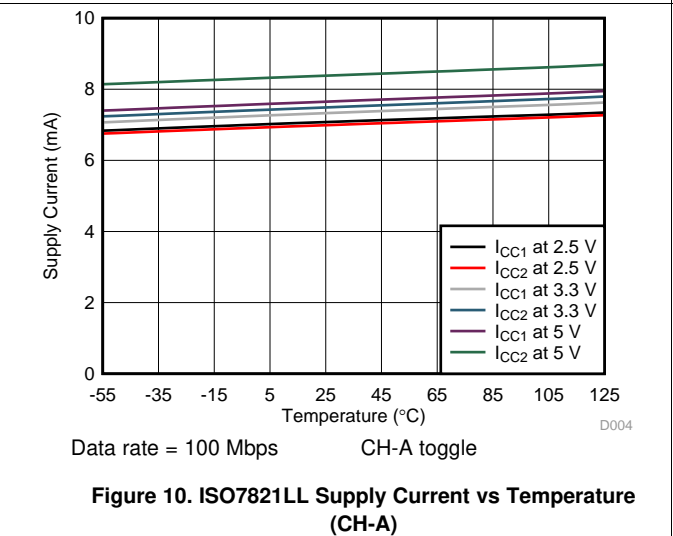

Figure 10. ISO7821LL Supply Current vs Temperature (CH-A)

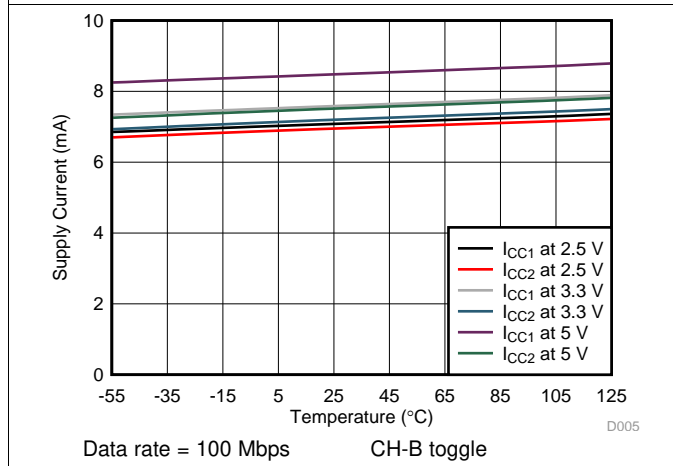

Figure 11. ISO7821LL Supply Current vs Temperature (CH-B)

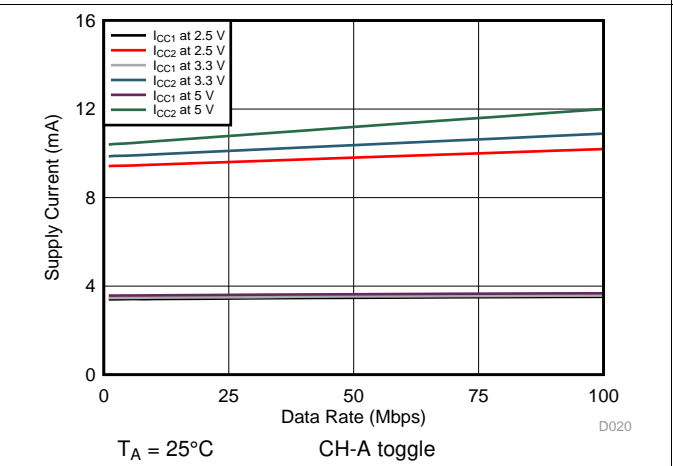
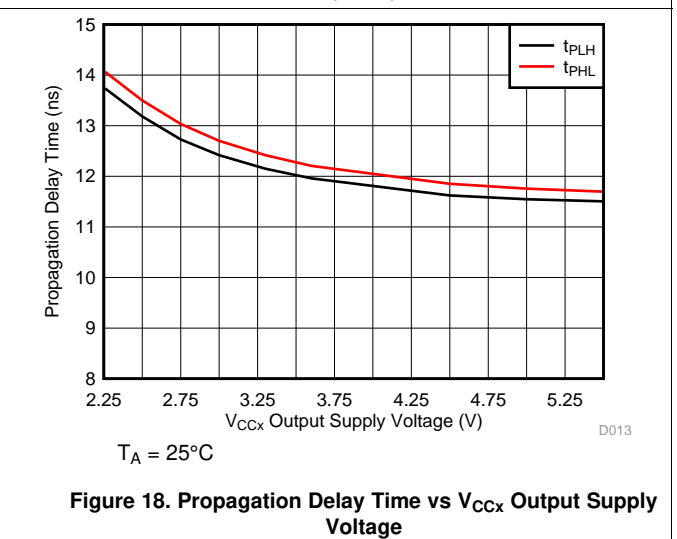
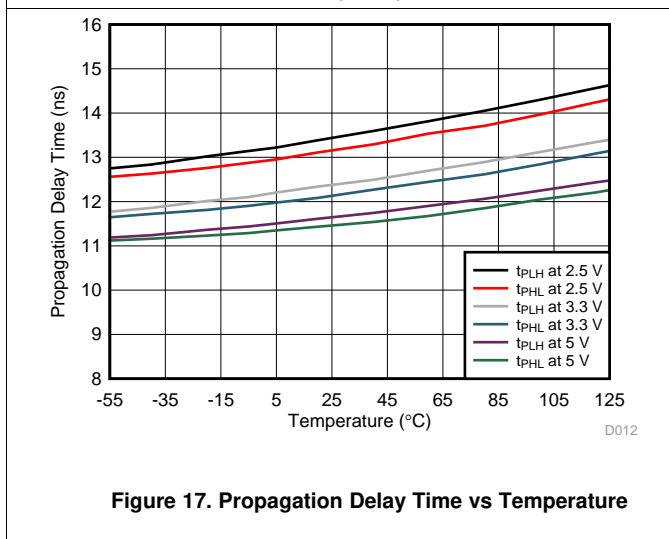
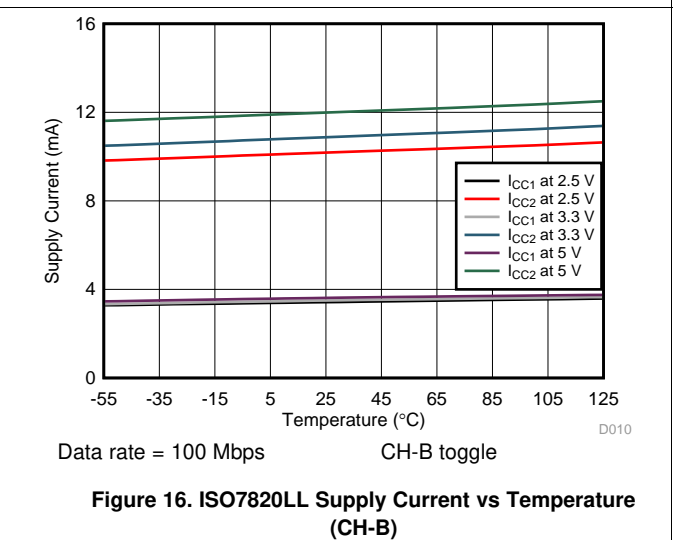
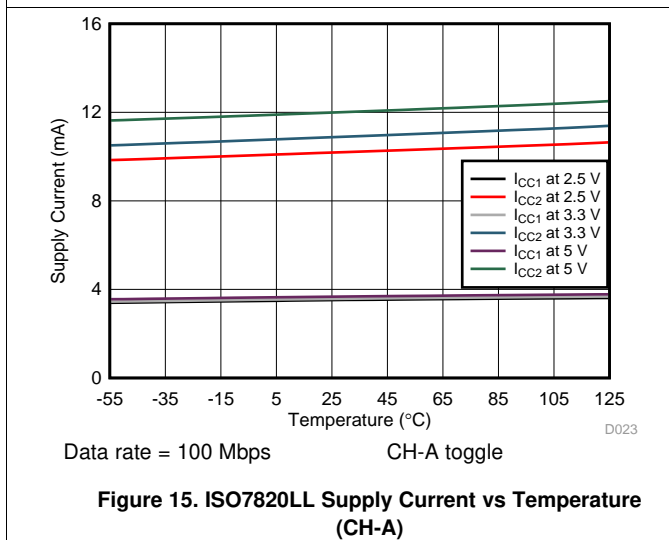
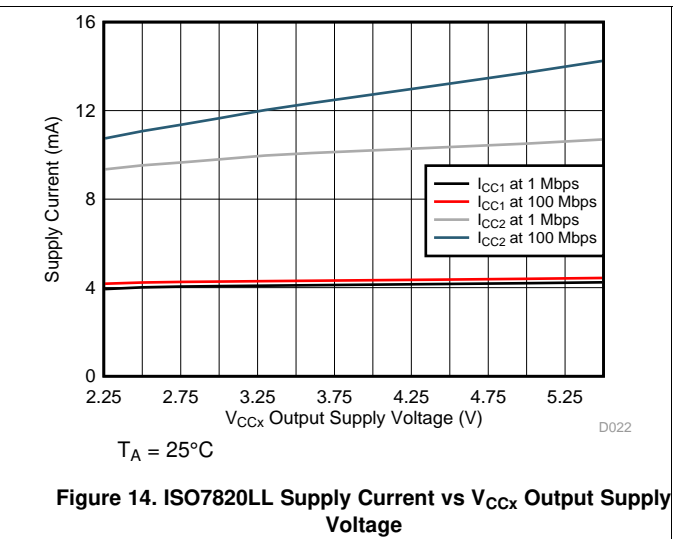
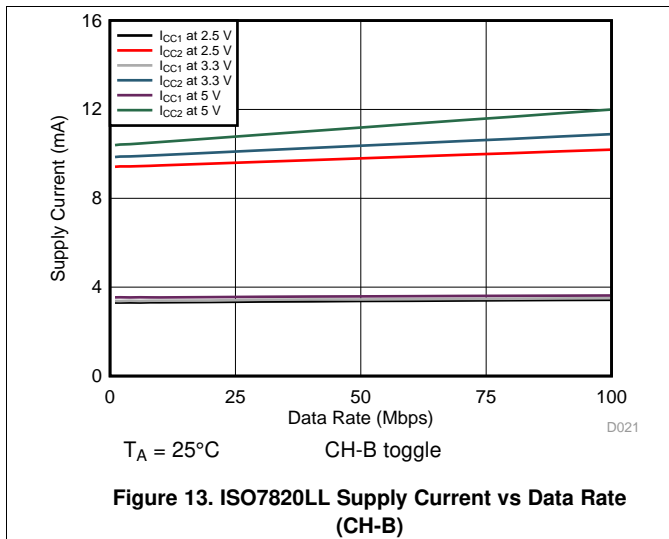
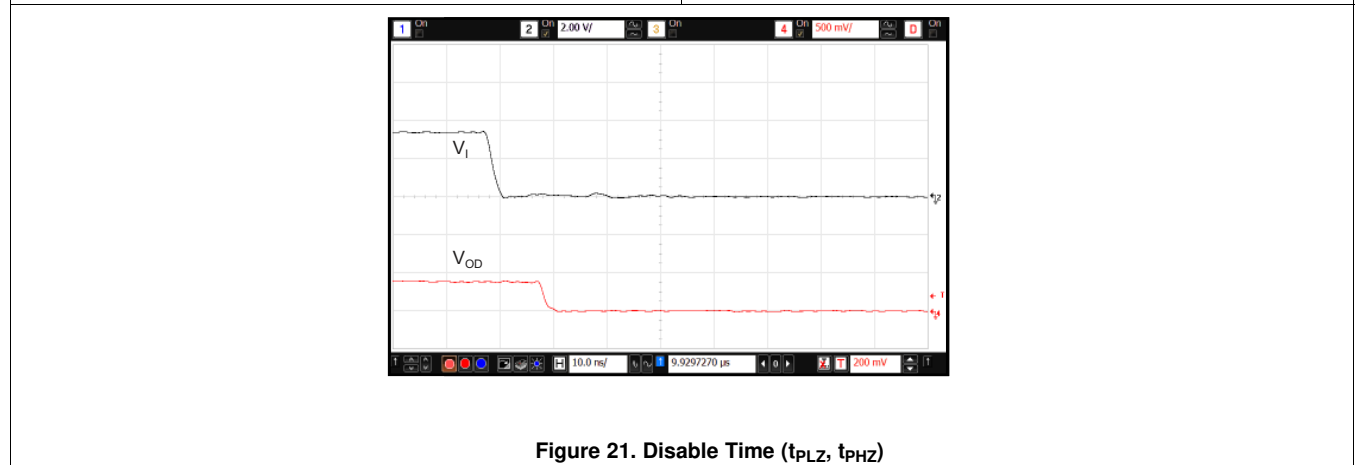
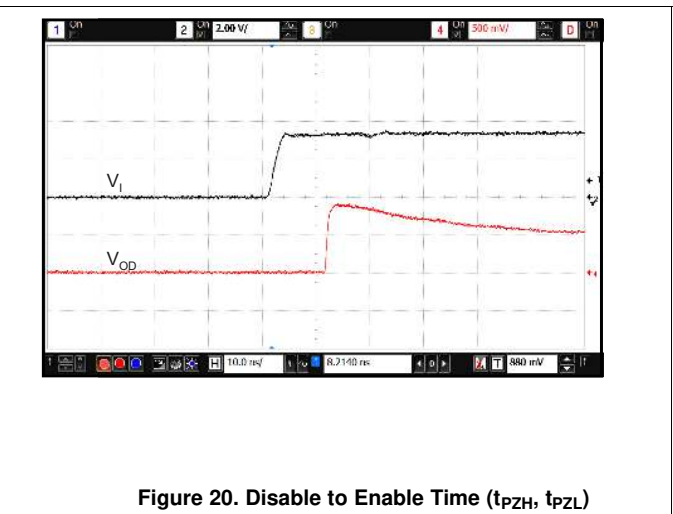
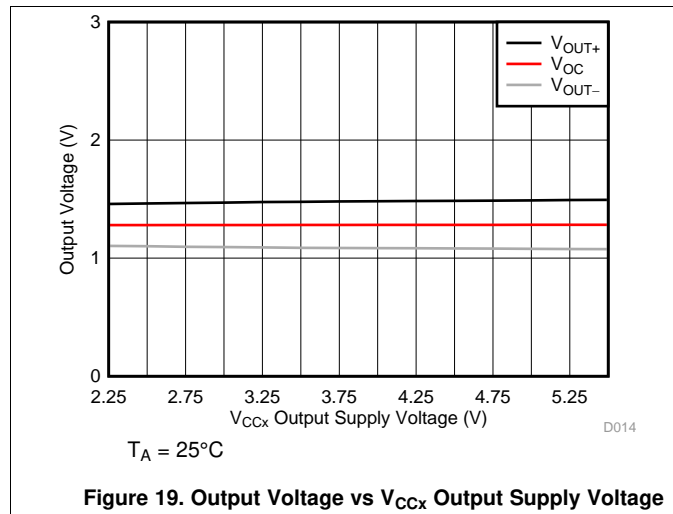

Figure 12. ISO7820LL Supply Current vs Data Rate (CH-A)

Typical Characteristics (continued)



Typical Characteristics (continued)



## 7 Parameter Measurement Information

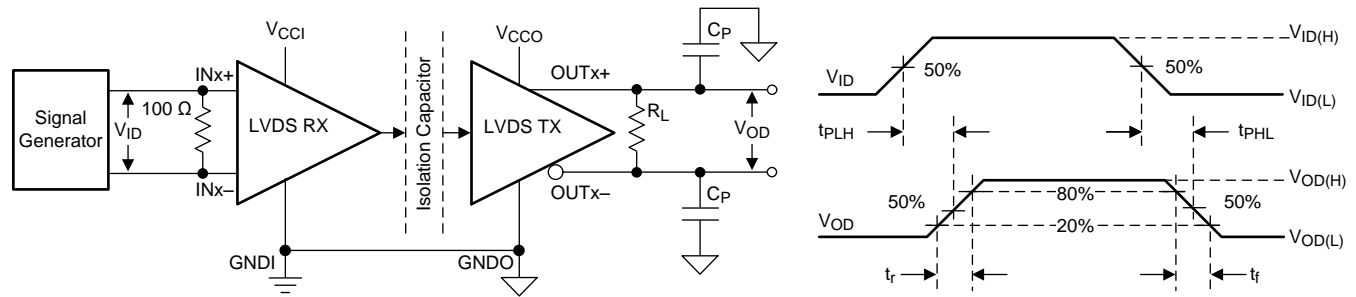

- A. The input pulse is supplied by a generator having the following characteristics: PRR  $\leq$  50 kHz, 50% duty cycle,  $t_r \leq$  3 ns,  $t_f \leq$  3 ns,  $Z_O = 50 \Omega$ .
- B.  $C_p = 5$  pF and includes instrumentation and fixture capacitance within  $\pm 20\%$ .

**Figure 22. Switching Characteristics Test Circuit and Voltage Waveforms**

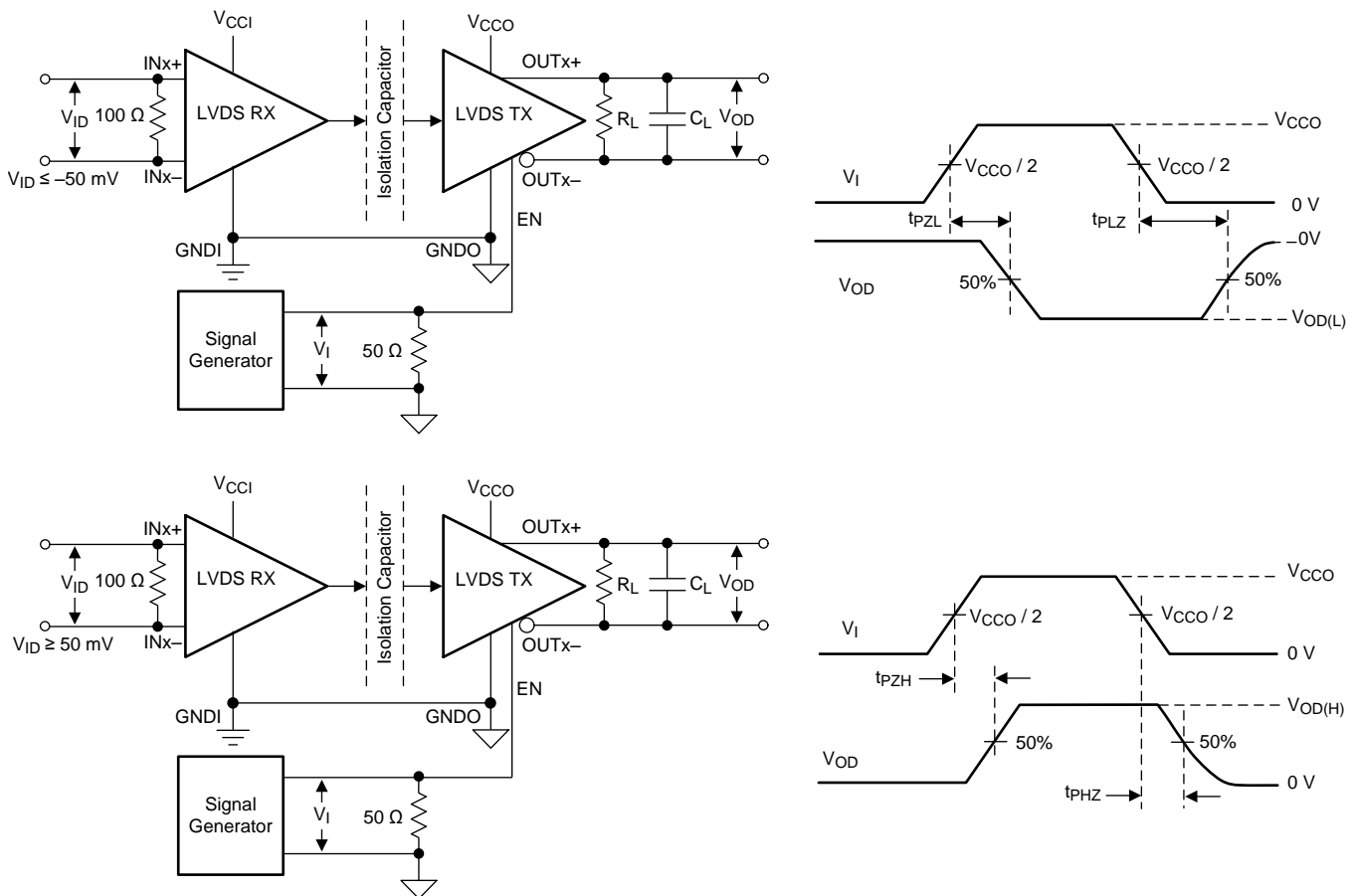

- A. The input pulse is supplied by a generator having the following characteristics: PRR  $\leq$  10 kHz, 50% duty cycle,  $t_r \leq$  3 ns,  $t_f \leq$  3 ns,  $Z_O = 50 \Omega$ .
- B.  $C_L = 5$  pF and includes instrumentation and fixture capacitance within  $\pm 20\%$ .

**Figure 23. Enable and Disable Propagation Delay Time Test Circuit and Waveform**



Parameter Measurement Information (continued)

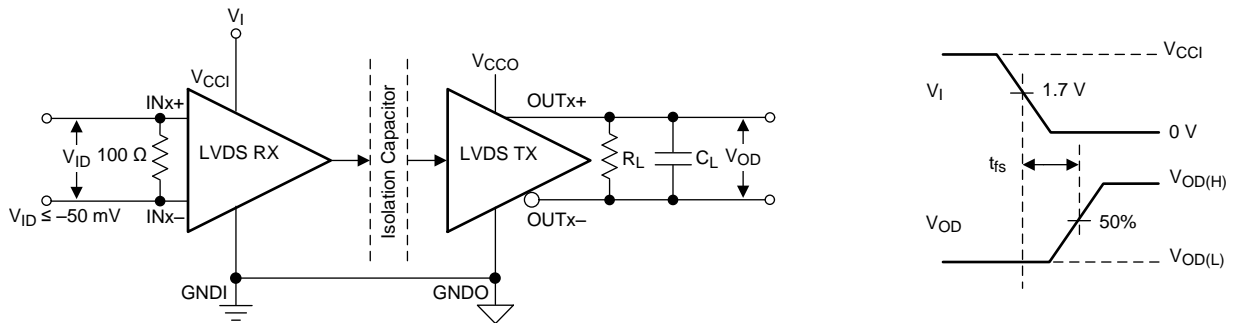

A.  $C_L = 5$  pF and includes instrumentation and fixture capacitance within  $\pm 20\%$ .

Figure 24. Default Output Delay Time Test Circuit and Voltage Waveforms

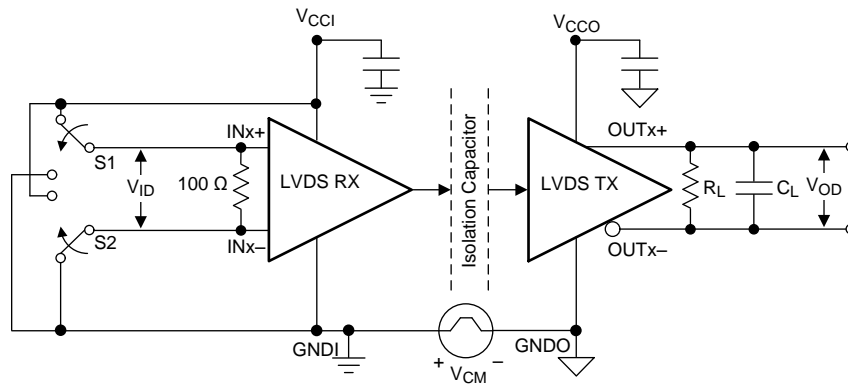

A.  $C_L = 5$  pF and includes instrumentation and fixture capacitance within  $\pm 20\%$ .

Figure 25. Common-Mode Transient Immunity Test Circuit

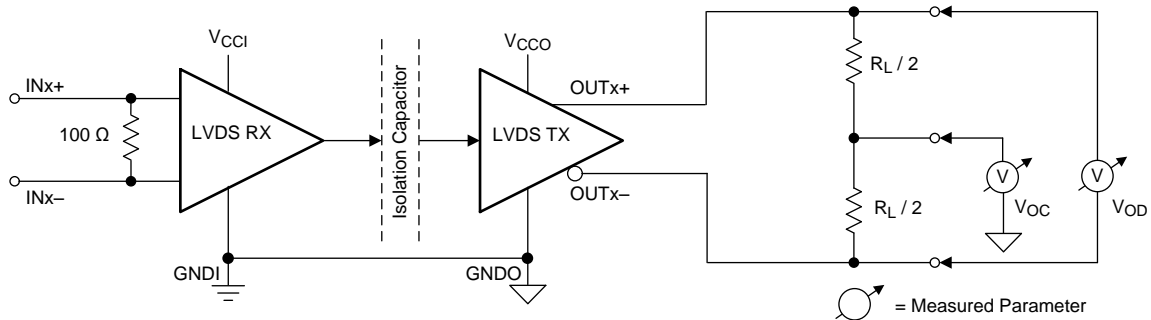
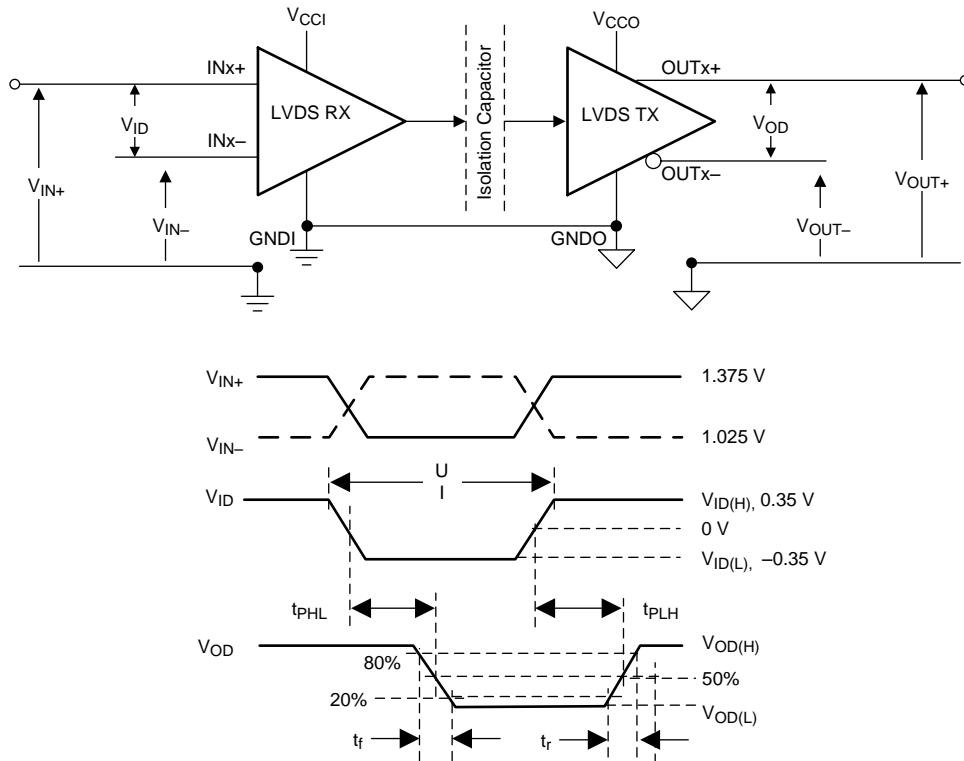

Figure 26. Driver Test Circuit

**Parameter Measurement Information (continued)**



**Figure 27. Voltage Definitions and Waveforms**

## 8 Detailed Description

### 8.1 Overview

The ISO782xLL is a family of isolated LVDS buffers. The differential signal received on the LVDS input pins is first converted to CMOS logic levels. The signal is then transmitted across a silicon-dioxide (SiO<sub>2</sub>) based capacitive-isolation barrier using an on-off keying (OOK) modulation scheme. A high frequency carrier transmitted across the barrier represents one logic state and an absence of a carrier represents the other logic state. On the other side of the barrier a demodulator converts the OOK signal back to logic levels, which is then converted to LVDS outputs by a differential driver. These devices incorporate advanced circuit techniques to maximize CMTI performance and minimize radiated emissions.

The ISO782xLL family of devices is TIA/EIA-644-A standard compliant. The LVDS transmitters drive a minimum differential-output voltage magnitude of 250 mV into a 100-Ω load, and the LVDS receivers are capable of detecting differential signals ≥50 mV in magnitude. The device consumes 10 mA per channel at 100 Mbps with 5-V supplies.

The [Functional Block Diagram](#) section shows a conceptual block diagram of one channel of the ISO782xLL family of devices.

### 8.2 Functional Block Diagram

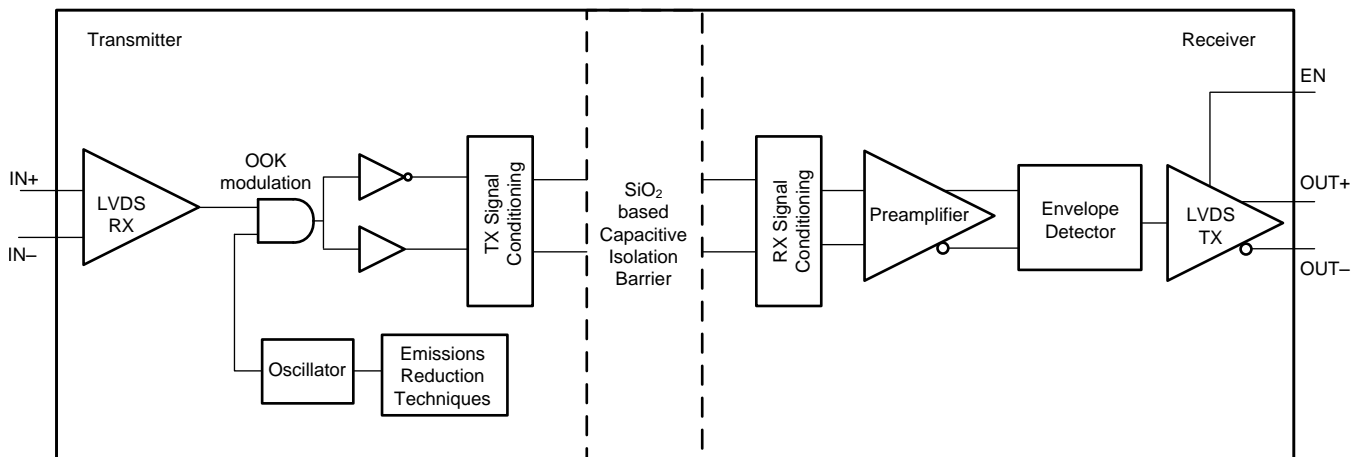

Copyright © 2016, Texas Instruments Incorporated

### 8.3 Feature Description

The ISO782xLL family of devices is available in two channel configurations with a default differential high-output state.

PART NUMBER	CHANNEL DIRECTION	RATED ISOLATION	MAXIMUM DATA RATE	DEFAULT DIFFERENTIAL OUTPUT
ISO7820LL	2 Forward	5700 V <sub>RMS</sub> / 8000 V <sub>PK</sub> <sup>(1)</sup>	100 Mbps	High
ISO7821LL	1 Forward, 1 Reverse			

(1) See the [Safety-Related Certifications](#) section for detailed isolation ratings.

### 8.4 Device Functional Modes

Table 1 lists the functional modes for the ISO782xLL family of devices.

**Table 1. ISO782xLL Function Table<sup>(1)</sup>**

V <sub>CCI</sub>	V <sub>CCO</sub>	INPUT (IN <sub>x±</sub> ) <sup>(2)</sup>	OUTPUT ENABLE (EN <sub>x</sub> )	OUTPUT (OUT <sub>x±</sub> ) <sup>(3)</sup>	COMMENTS
PU	PU	H	H or open	H	Normal Operation: A channel output assumes the logic state of the input.
		L	H or open	L	
		I	H or open	H or L	
X	PU	X	L	Z	A low-logic state at the output enable causes the outputs to be in high impedance.
PD	PU	X	H or open	H	Default mode: When V <sub>CCI</sub> is unpowered, a channel output assumes the logic high state. When V <sub>CCI</sub> transitions from unpowered to powered up, a channel output assumes the logic state of the input. When V <sub>CCI</sub> transitions from powered up to unpowered, a channel output assumes the selected default high state.
X	PD	X	X	Undetermined	When V <sub>CCO</sub> is unpowered, a channel output is undetermined. When V <sub>CCO</sub> transitions from unpowered to powered-up, a channel output assumes the logic state of the input

(1) V<sub>CCI</sub> = input-side V<sub>CC</sub>; V<sub>CCO</sub> = output-side V<sub>CC</sub>; PU = powered up (V<sub>CCx</sub> ≥ 2.25 V); PD = powered down (V<sub>CCx</sub> ≤ 1.7 V); X = irrelevant

(2) Input (IN<sub>x±</sub>): H = high level (V<sub>ID</sub> ≥ 50 mV); L = low level (V<sub>ID</sub> ≤ -50 mV); I = indeterminate (-50 mV < V<sub>ID</sub> < 50 mV)

(3) Output (OUT<sub>x±</sub>): H = high level (V<sub>OD</sub> ≥ 250 mV); L = low level (V<sub>OD</sub> ≤ -250 mV); Z = high impedance.

#### 8.4.1 Device I/O Schematics

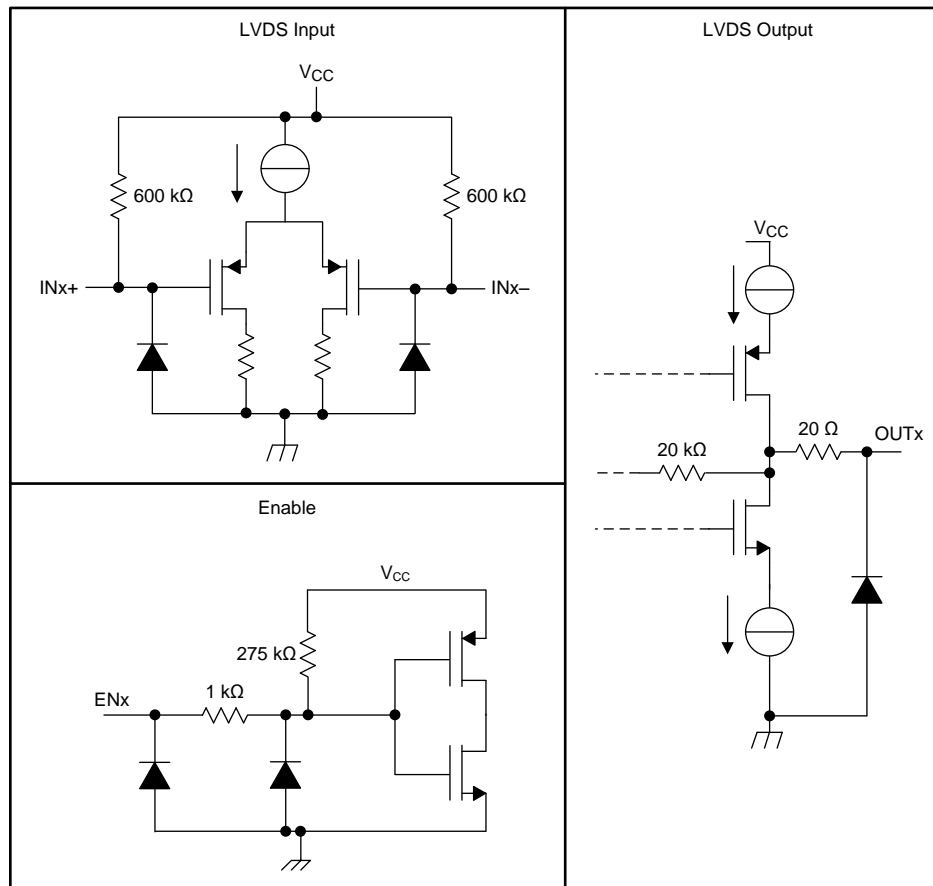

**Figure 28. Device I/O Schematics**

## 9 Application and Implementation

### NOTE

Information in the following applications sections is not part of the TI component specification, and TI does not warrant its accuracy or completeness. TI's customers are responsible for determining suitability of components for their purposes. Customers should validate and test their design implementation to confirm system functionality.

### 9.1 Application Information

The ISO782xLL is a family of high-performance, reinforced isolated dual-LVDS buffers. Isolation can be used to help achieve human and system safety, to overcome ground potential difference (GPD), or to improve noise immunity and system performance.

The LVDS signaling can be used over most interfaces to achieve higher data rates because the LVDS is only a physical layer. LVDS can also be used for a proprietary communication scheme implemented between a host controller and a slave. Example use cases include connecting a high-speed I/O module to a host controller, a subsystem connecting to a backplane, and connection between two high-speed subsystems. Many of these systems operate under harsh environments making them susceptible to electromagnetic interferences, voltage surges, electrical fast transients (EFT), and other disturbances. These systems must also meet strict limits on radiated emissions. Using isolation in combination with a robust low-noise signaling standard such as LVDS, achieves both high immunity to noise and low emissions.

Example end applications that could benefit from the ISO782xLL family of devices include high-voltage motor control, test and measurement, industrial automation, and medical equipment.

### 9.2 Typical Application

One application for isolated LVDS buffers is for point-to-point communication between two high-speed capable, application-specific integrated circuits (ASICs) or FPGAs. In a high-voltage motor control application, for example, Node 1 could be a controller on a low-voltage or earth referenced board, and Node 2, could be controller placed on the power board, biased to high voltage. [Figure 29](#) and [Figure 30](#) show the application schematics.

[Figure 30](#) provides further details of using the ISO782xLL family of devices to isolate the LVDS interface. The LVDS connection to the ISO782xLL family of devices can be traces on a board (shown as straight lines between Node 1 and the ISO782xLL device), a twisted pair cable (as shown between Node 2 and the ISO782xLL device), or any other controlled impedance channel. Differential 100-Ω terminations are placed near each LVDS receiver. The characteristic impedance of the channel should also be 100-Ω differential.

In the example shown in [Figure 29](#) and [Figure 30](#), the ISO782xLL family of devices provides reinforced or safety isolation between the high-voltage elements of the motor drive and the low-voltage control circuitry. This configuration also ensures reliable communication, regardless of the high conducted and radiated noise present in the system.

Typical Application (continued)

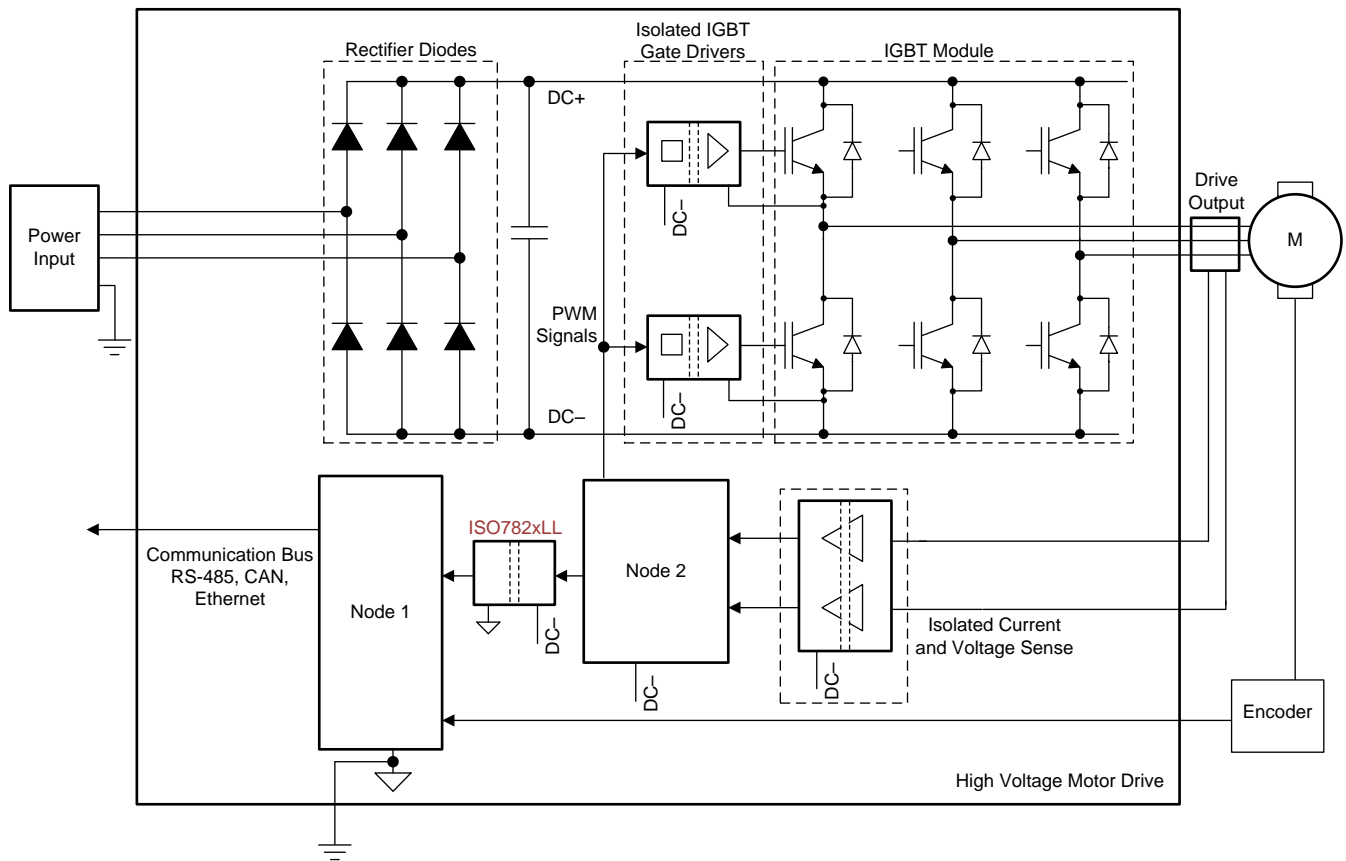

Copyright © 2016, Texas Instruments Incorporated

Figure 29. Isolated LVDS Interface in Motor Control Application

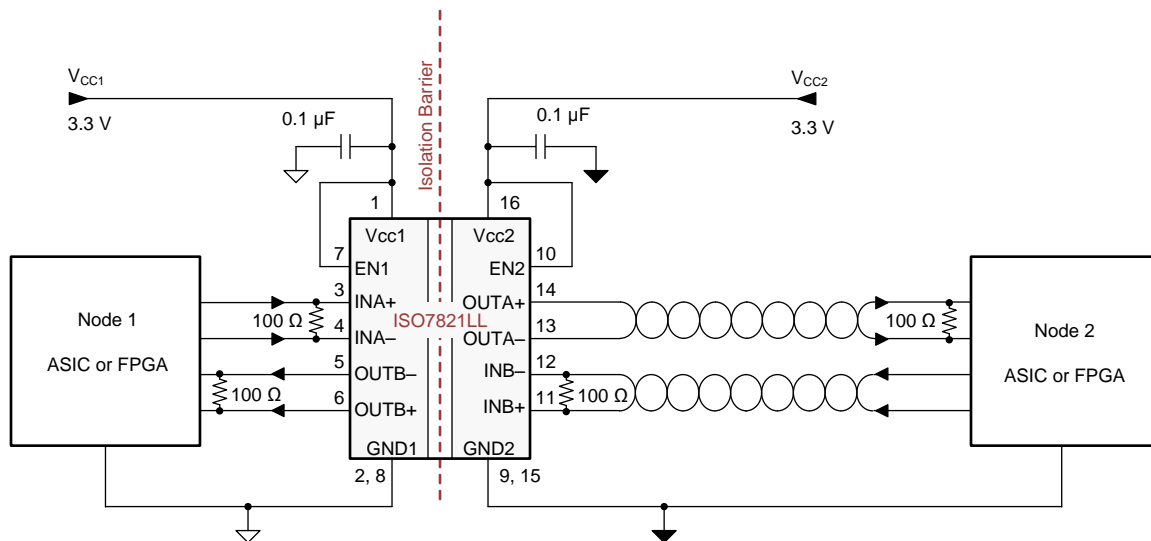

Copyright © 2016, Texas Instruments Incorporated

Figure 30. Isolated LVDS Interface Between Two Nodes (ASIC or FPGA)

## Typical Application (continued)

### 9.2.1 Design Requirements

For the ISO782xLL family of devices, use the parameters listed in [Table 2](#).

**Table 2. Design Parameters**

PARAMETER	VALUE
Supply voltage range, $V_{CC1}$ and $V_{CC2}$	2.25 V to 5.5 V
Receiver common-mode voltage range	For $V_{CCx} \geq 3$ V: $0.5  V_{ID} $ to $2.4 - 0.5  V_{ID} $
	For $V_{CCx} < 3$ V: $0.5  V_{ID} $ to $V_{CCx} - 0.6 - 0.5  V_{ID} $
External termination resistance	100 $\Omega$
Interconnect differential characteristic impedance	100 $\Omega$
Signaling rate	0 to 100 Mbps
Decoupling capacitor from $V_{CC1}$ and GND1	0.1 $\mu$ F
Decoupling capacitor from $V_{CC2}$ and GND2	0.1 $\mu$ F

### 9.2.2 Detailed Design Procedure

The ISO782xLL family of devices has minimum requirements on external components for correct operation. External bypass capacitors (0.1  $\mu$ F) are required for both supplies ( $V_{CC1}$  and  $V_{CC2}$ ). A termination resistor with a value of 100  $\Omega$  is required between each differential input pair (INx+ and INx-), with the resistors placed as close to the device pins as possible. A differential termination resistor with a value of 100  $\Omega$  is required on the far end for the LVDS transmitters. [Figure 31](#) and [Figure 32](#) show these connections.

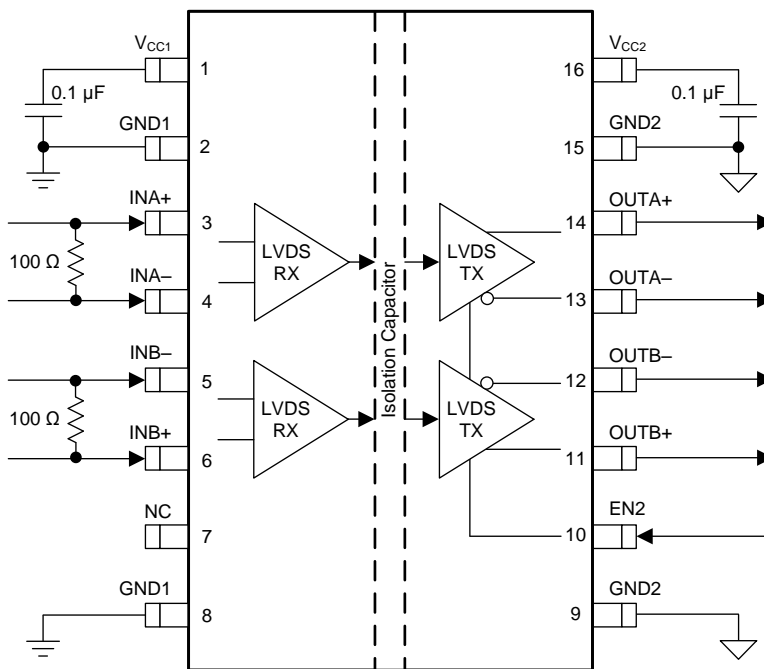

**Figure 31. Typical ISO7820LL Circuit Hook-Up**

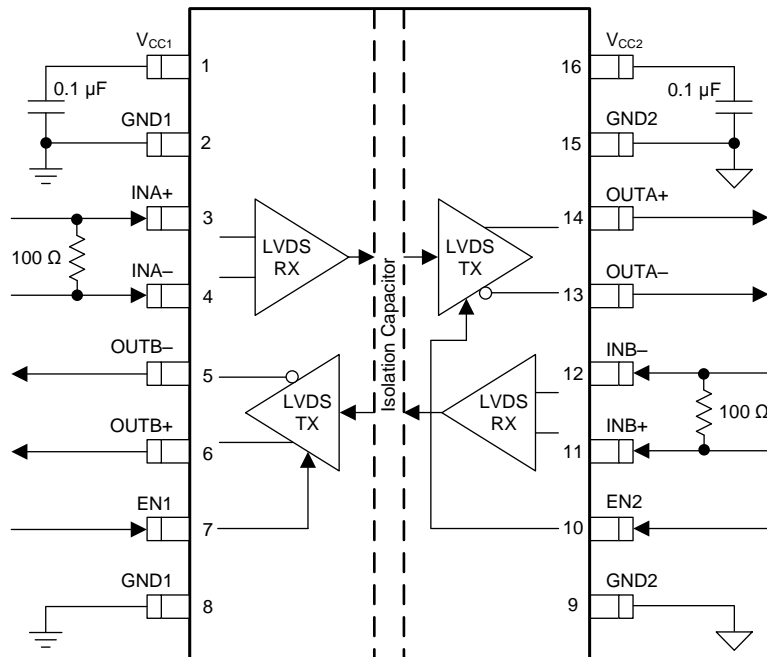

**Figure 32. Typical ISO7821LL Circuit Hook-Up**

### 9.2.2.1 Electromagnetic Compatibility (EMC) Considerations

Many applications in harsh industrial environment are sensitive to disturbances such as electrostatic discharge (ESD), electrical fast transient (EFT), surge and electromagnetic emissions. These electromagnetic disturbances are regulated by international standards such as IEC 61000-4-x and CISPR 22. Although system-level performance and reliability depends, to a large extent, on the application board design and layout, the ISO782xLL family of devices incorporates many chip-level design improvements for overall system robustness. Some of these improvements include:

- Robust ESD protection cells for input and output signal pins and inter-chip bond pads.
- Low-resistance connectivity of ESD cells to supply and ground pins.
- Enhanced performance of high voltage isolation capacitor for better tolerance of ESD, EFT and surge events.
- Bigger on-chip decoupling capacitors to bypass undesirable high energy signals through a low impedance path.
- PMOS and NMOS devices isolated from each other by using guard rings to avoid triggering of parasitic SCRs.
- Reduced common mode currents across the isolation barrier by ensuring purely differential internal operation.



### 9.2.3 Application Curve

Figure 33 shows a typical eye diagram of the ISO782xLL family of devices which indicates low jitter and a wide-open eye at the maximum data rate of 100 Mbps.

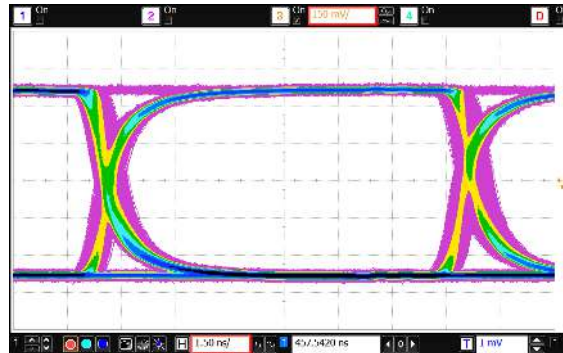

Figure 33. Eye Diagram at 100 Mbps PRBS, 3.3 V and 25°C

## 10 Power Supply Recommendations

To help ensure reliable operation at data rates and supply voltages, a 0.1- $\mu$ F bypass capacitor is recommended at the input and output supply pins ( $V_{CC1}$  and  $V_{CC2}$ ). The capacitors should be placed as close to the supply pins as possible. If only a single primary-side power supply is available in an application, isolated power can be generated for the secondary-side with the help of a transformer driver such as Texas Instruments' [SN6501](#) or [SN6505](#). For such applications, detailed power supply design and transformer selection recommendations are available in the following data sheets: [SN6501 Transformer Driver for Isolated Power Supplies](#) (SLLSEA0) and [SN6505 Low-Noise 1-A Transformer Drivers for Isolated Power Supplies](#) (SLLSEP9).

## 11 Layout

### 11.1 Layout Guidelines

A minimum of four layers is required to accomplish a low EMI PCB design (see [Figure 34](#)). Layer stacking should be in the following order (top-to-bottom): high-speed signal layer, ground plane, power plane and low-frequency signal layer.

- Routing the high-speed traces on the top layer avoids the use of vias (and the introduction of their inductances) and allows for clean interconnects between the isolator and the transmitter and receiver circuits of the data link.
- Placing a solid ground plane next to the high-speed signal layer establishes controlled impedance for transmission line interconnects and provides an excellent low-inductance path for the return current flow.
- Placing the power plane next to the ground plane creates additional high-frequency bypass capacitance of approximately 100 pF/in<sup>2</sup>.
- Routing the slower speed control signals on the bottom layer allows for greater flexibility as these signal links usually have margin to tolerate discontinuities such as vias.
- While routing differential traces on a board, TI recommends that the distance between two differential pairs be much higher (at least 2x) than the distance between the traces in a differential pair. This distance minimizes crosstalk between the two differential pairs.

If an additional supply voltage plane or signal layer is needed, add a second power or ground plane system to the stack to keep it symmetrical. This makes the stack mechanically stable and prevents it from warping. Also the power and ground plane of each power system can be placed closer together, thus increasing the high-frequency bypass capacitance significantly.

The ISO782xLL family of devices requires no special layout considerations to mitigate electromagnetic emissions.

For detailed layout recommendations, see the [Digital Isolator Design Guide](#) (SLLA284).

#### 11.1.1 PCB Material

For digital circuit boards operating at less than 150 Mbps (or rise and fall times higher than 1 ns) and trace lengths of up to 10 inches, use standard FR-4 UL94V-0 epoxy-glass as PCB material. This PCB is preferred over cheaper alternatives because of lower dielectric losses at high frequencies, less moisture absorption, greater strength and stiffness, and self-extinguishing flammability-characteristics.

### 11.2 Layout Example

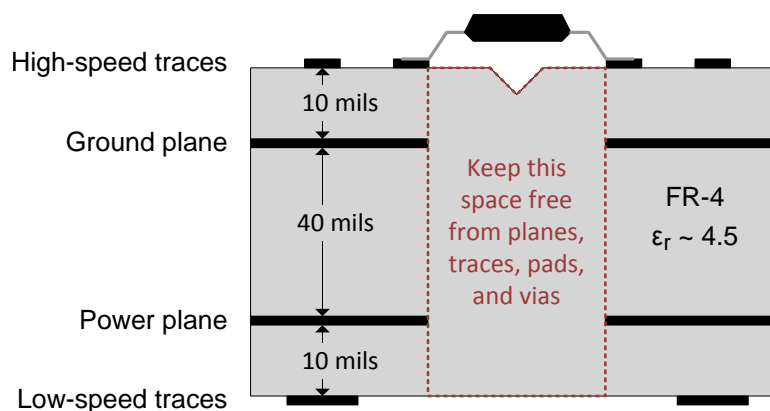

**Figure 34. Layout Example**

## 12 Device and Documentation Support

### 12.1 Documentation Support

#### 12.1.1 Related Documentation

For related documentation see the following:

- [Digital Isolator Design Guide](#) (SLLA284)
- [ISO782xLLx Isolated Dual LVDS Buffer Evaluation Module](#) (SLLU240)
- [Isolation Glossary](#) (SLLA353)
- [LVDS Owner's Manual](#) (SNLA187)
- [SN6501 Transformer Driver for Isolated Power Supplies](#) (SLLSEA0)
- [SN6505 Low-Noise 1-A Transformer Drivers for Isolated Power Supplies](#) (SLLSEP9)

#### 12.2 Receiving Notification of Documentation Updates

To receive notification of documentation updates — go to the product folder for your device on ti.com. In the upper right-hand corner, click the *Alert me* button to register and receive a weekly digest of product information that has changed (if any). For change details, check the revision history of any revised document.

#### 12.3 Community Resources

The following links connect to TI community resources. Linked contents are provided "AS IS" by the respective contributors. They do not constitute TI specifications and do not necessarily reflect TI's views; see TI's [Terms of Use](#).

**TI E2E™ Online Community** *TI's Engineer-to-Engineer (E2E) Community*. Created to foster collaboration among engineers. At e2e.ti.com, you can ask questions, share knowledge, explore ideas and help solve problems with fellow engineers.

**Design Support** *TI's Design Support* Quickly find helpful E2E forums along with design support tools and contact information for technical support.

#### 12.4 Trademarks

E2E is a trademark of Texas Instruments.  
All other trademarks are the property of their respective owners.

#### 12.5 Electrostatic Discharge Caution



This integrated circuit can be damaged by ESD. Texas Instruments recommends that all integrated circuits be handled with appropriate precautions. Failure to observe proper handling and installation procedures can cause damage.

ESD damage can range from subtle performance degradation to complete device failure. Precision integrated circuits may be more susceptible to damage because very small parametric changes could cause the device not to meet its published specifications.

#### 12.6 Glossary

[SLYZ022](#) — *TI Glossary*.

This glossary lists and explains terms, acronyms, and definitions.

## 13 Mechanical, Packaging, and Orderable Information

The following pages include mechanical, packaging, and orderable information. This information is the most current data available for the designated devices. This data is subject to change without notice and revision of this document. For browser-based versions of this data sheet, refer to the left-hand navigation.

**PACKAGING INFORMATION**

Orderable Device	Status (1)	Package Type	Package Drawing	Pins	Package Qty	Eco Plan (2)	Lead finish/ Ball material (6)	MSL Peak Temp (3)	Op Temp (°C)	Device Marking (4/5)	Samples
ISO7820LLDW	ACTIVE	SOIC	DW	16	40	RoHS & Green	NIPDAU	Level-2-260C-1 YEAR	-55 to 125	ISO7820LL	<a href="#">Samples</a>
ISO7820LLDWR	ACTIVE	SOIC	DW	16	2000	RoHS & Green	NIPDAU	Level-2-260C-1 YEAR	-55 to 125	ISO7820LL	<a href="#">Samples</a>
ISO7820LLDWW	ACTIVE	SOIC	DWW	16	45	RoHS & Green	NIPDAU	Level-3-260C-168 HR	-55 to 125	ISO7820LL	<a href="#">Samples</a>
ISO7820LLDWWR	ACTIVE	SOIC	DWW	16	1000	RoHS & Green	NIPDAU	Level-3-260C-168 HR	-55 to 125	ISO7820LL	<a href="#">Samples</a>
ISO7821LLDW	ACTIVE	SOIC	DW	16	40	RoHS & Green	NIPDAU	Level-2-260C-1 YEAR	-55 to 125	ISO7821LL	<a href="#">Samples</a>
ISO7821LLDWR	ACTIVE	SOIC	DW	16	2000	RoHS & Green	NIPDAU	Level-2-260C-1 YEAR	-55 to 125	ISO7821LL	<a href="#">Samples</a>
ISO7821LLDWW	ACTIVE	SOIC	DWW	16	45	RoHS & Green	NIPDAU	Level-3-260C-168 HR	-55 to 125	ISO7821LL	<a href="#">Samples</a>
ISO7821LLDWWR	ACTIVE	SOIC	DWW	16	1000	RoHS & Green	NIPDAU	Level-3-260C-168 HR	-55 to 125	ISO7821LL	<a href="#">Samples</a>

(1) The marketing status values are defined as follows:

**ACTIVE:** Product device recommended for new designs.

**LIFEBUY:** TI has announced that the device will be discontinued, and a lifetime-buy period is in effect.

**NRND:** Not recommended for new designs. Device is in production to support existing customers, but TI does not recommend using this part in a new design.

**PREVIEW:** Device has been announced but is not in production. Samples may or may not be available.

**OBSELETE:** TI has discontinued the production of the device.

(2) **RoHS:** TI defines "RoHS" to mean semiconductor products that are compliant with the current EU RoHS requirements for all 10 RoHS substances, including the requirement that RoHS substance do not exceed 0.1% by weight in homogeneous materials. Where designed to be soldered at high temperatures, "RoHS" products are suitable for use in specified lead-free processes. TI may reference these types of products as "Pb-Free".

**RoHS Exempt:** TI defines "RoHS Exempt" to mean products that contain lead but are compliant with EU RoHS pursuant to a specific EU RoHS exemption.

**Green:** TI defines "Green" to mean the content of Chlorine (Cl) and Bromine (Br) based flame retardants meet JS709B low halogen requirements of <=1000ppm threshold. Antimony trioxide based flame retardants must also meet the <=1000ppm threshold requirement.

(3) MSL, Peak Temp. - The Moisture Sensitivity Level rating according to the JEDEC industry standard classifications, and peak solder temperature.

(4) There may be additional marking, which relates to the logo, the lot trace code information, or the environmental category on the device.

(5) Multiple Device Markings will be inside parentheses. Only one Device Marking contained in parentheses and separated by a "~" will appear on a device. If a line is indented then it is a continuation of the previous line and the two combined represent the entire Device Marking for that device.

<sup>(6)</sup> Lead finish/Ball material - Orderable Devices may have multiple material finish options. Finish options are separated by a vertical ruled line. Lead finish/Ball material values may wrap to two lines if the finish value exceeds the maximum column width.

**Important Information and Disclaimer:** The information provided on this page represents TI's knowledge and belief as of the date that it is provided. TI bases its knowledge and belief on information provided by third parties, and makes no representation or warranty as to the accuracy of such information. Efforts are underway to better integrate information from third parties. TI has taken and continues to take reasonable steps to provide representative and accurate information but may not have conducted destructive testing or chemical analysis on incoming materials and chemicals. TI and TI suppliers consider certain information to be proprietary, and thus CAS numbers and other limited information may not be available for release.

In no event shall TI's liability arising out of such information exceed the total purchase price of the TI part(s) at issue in this document sold by TI to Customer on an annual basis.

**TAPE AND REEL INFORMATION**

**QUADRANT ASSIGNMENTS FOR PIN 1 ORIENTATION IN TAPE**

\*All dimensions are nominal

Device	Package Type	Package Drawing	Pins	SPQ	Reel Diameter (mm)	Reel Width W1 (mm)	A0 (mm)	B0 (mm)	K0 (mm)	P1 (mm)	W (mm)	Pin1 Quadrant
ISO7820LLDWR	SOIC	DW	16	2000	330.0	16.4	10.75	10.7	2.7	12.0	16.0	Q1
ISO7820LLDWWR	SOIC	DWW	16	1000	330.0	24.4	18.0	10.0	3.0	20.0	24.0	Q1
ISO7821LLDWR	SOIC	DW	16	2000	330.0	16.4	10.75	10.7	2.7	12.0	16.0	Q1
ISO7821LLDWWR	SOIC	DWW	16	1000	330.0	24.4	18.0	10.0	3.0	20.0	24.0	Q1

**TAPE AND REEL BOX DIMENSIONS**

\*All dimensions are nominal

Device	Package Type	Package Drawing	Pins	SPQ	Length (mm)	Width (mm)	Height (mm)
ISO7820LLDWR	SOIC	DW	16	2000	350.0	350.0	43.0
ISO7820LLDWWWR	SOIC	DWW	16	1000	350.0	350.0	43.0
ISO7821LLDWR	SOIC	DW	16	2000	350.0	350.0	43.0
ISO7821LLDWWWR	SOIC	DWW	16	1000	350.0	350.0	43.0

**TUBE**

\*All dimensions are nominal

Device	Package Name	Package Type	Pins	SPQ	L (mm)	W (mm)	T (μm)	B (mm)
ISO7820LLDW	DW	SOIC	16	40	506.98	12.7	4826	6.6
ISO7820LLDWW	DWW	SOIC	16	45	507	20	5000	9
ISO7821LLDW	DW	SOIC	16	40	506.98	12.7	4826	6.6
ISO7821LLDWW	DWW	SOIC	16	45	507	20	5000	9



## GENERIC PACKAGE VIEW

**DW 16**

**SOIC - 2.65 mm max height**

7.5 x 10.3, 1.27 mm pitch

SMALL OUTLINE INTEGRATED CIRCUIT

This image is a representation of the package family, actual package may vary.  
Refer to the product data sheet for package details.

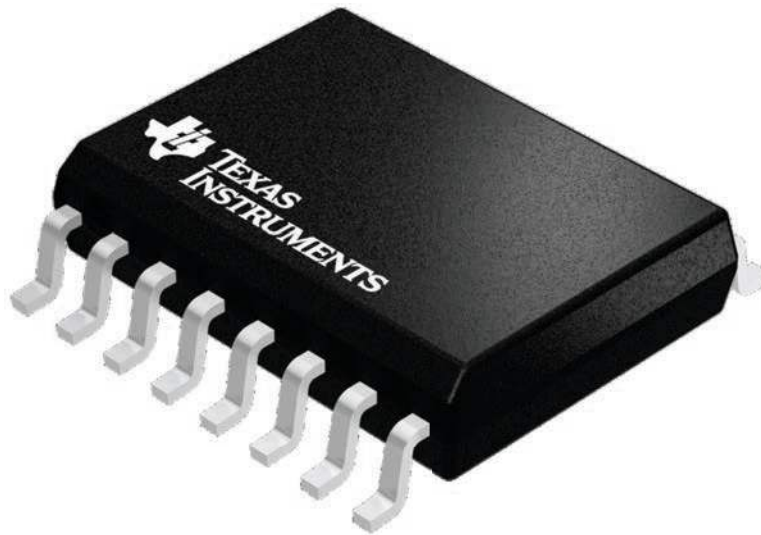

4224780/A



# DW0016B

# PACKAGE OUTLINE

## SOIC - 2.65 mm max height

SOIC

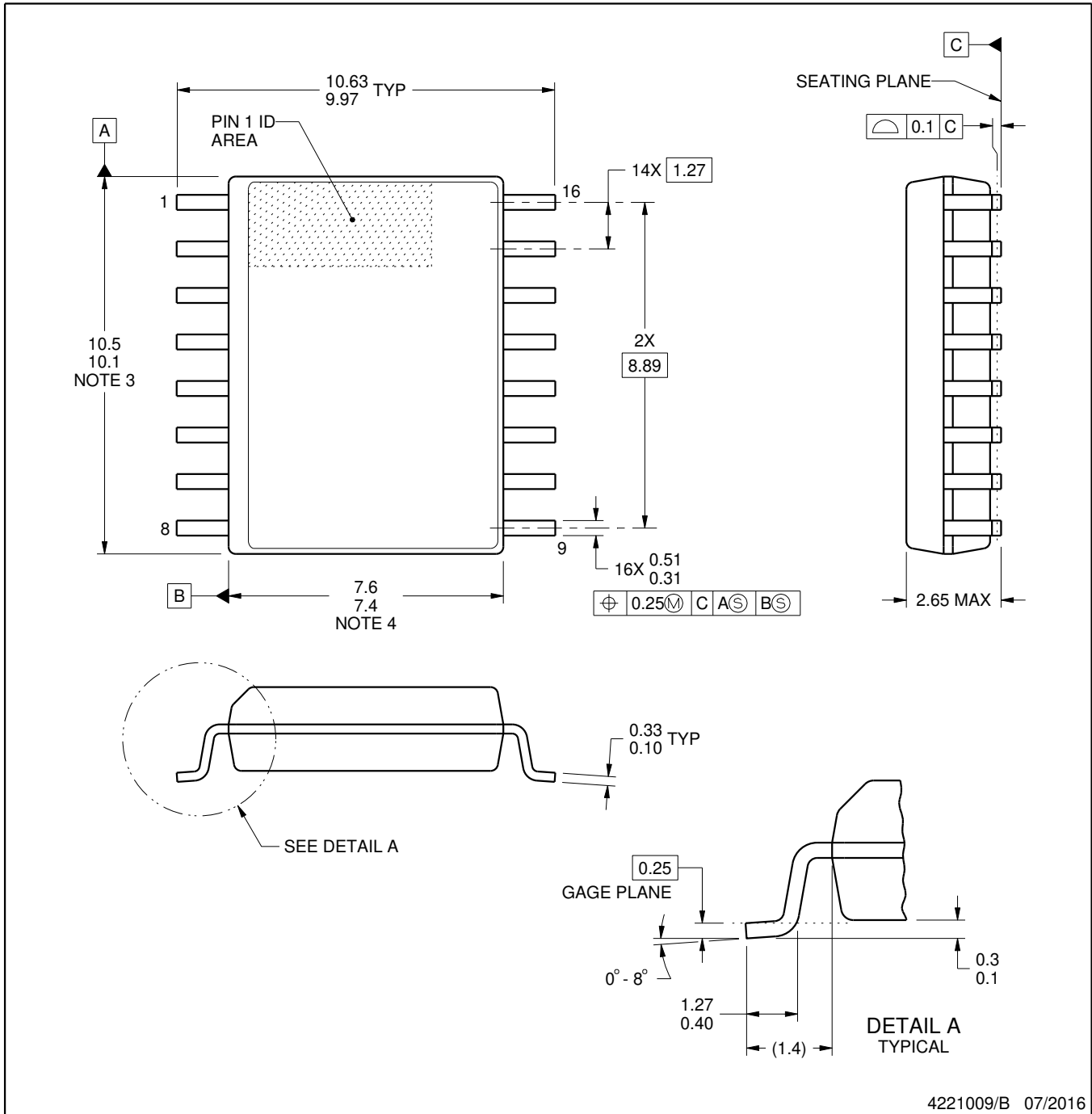

### NOTES:

1. All linear dimensions are in millimeters. Dimensions in parenthesis are for reference only. Dimensioning and tolerancing per ASME Y14.5M.
2. This drawing is subject to change without notice.
3. This dimension does not include mold flash, protrusions, or gate burrs. Mold flash, protrusions, or gate burrs shall not exceed 0.15 mm, per side.
4. This dimension does not include interlead flash. Interlead flash shall not exceed 0.25 mm, per side.
5. Reference JEDEC registration MS-013.

# EXAMPLE BOARD LAYOUT

DW0016B

SOIC - 2.65 mm max height

SOIC

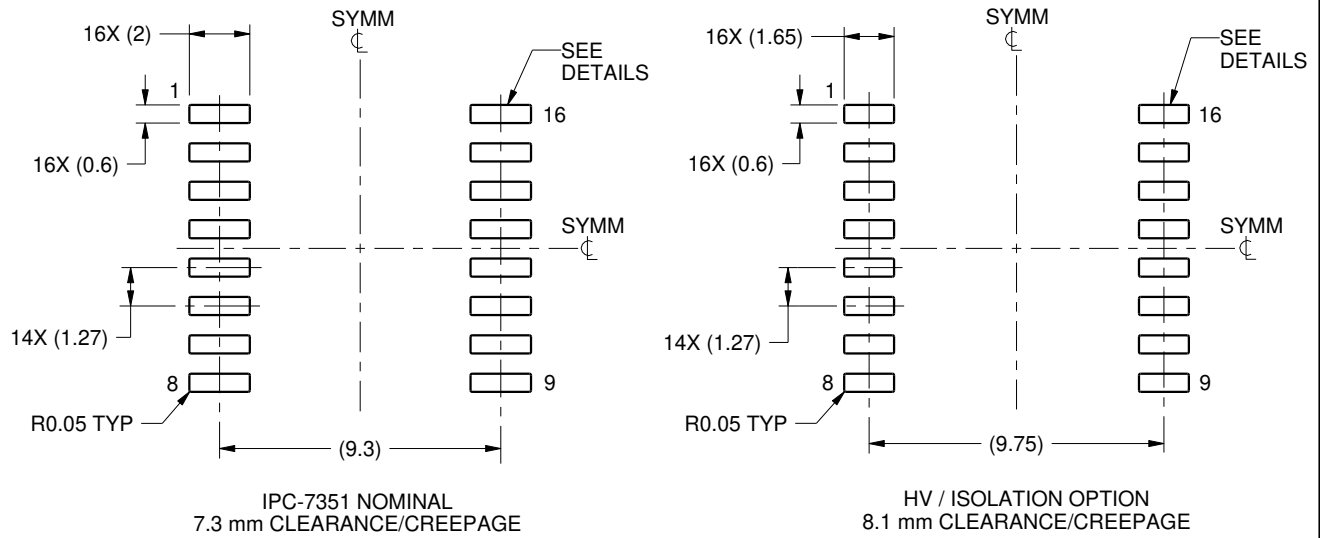

LAND PATTERN EXAMPLE  
SCALE:4X

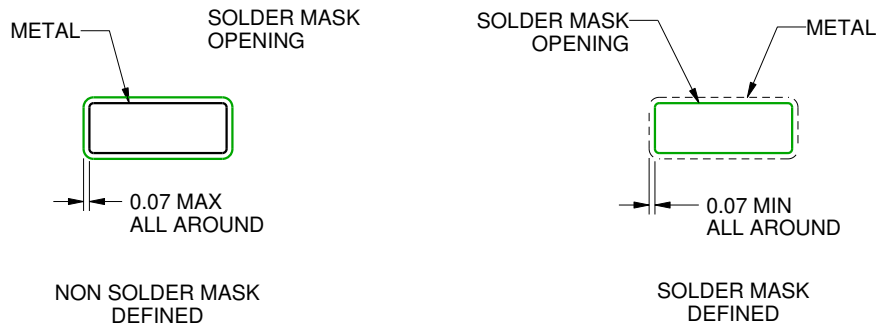

SOLDER MASK DETAILS

4221009/B 07/2016

NOTES: (continued)

- 6. Publication IPC-7351 may have alternate designs.
- 7. Solder mask tolerances between and around signal pads can vary based on board fabrication site.

# EXAMPLE STENCIL DESIGN

DW0016B

SOIC - 2.65 mm max height

SOIC

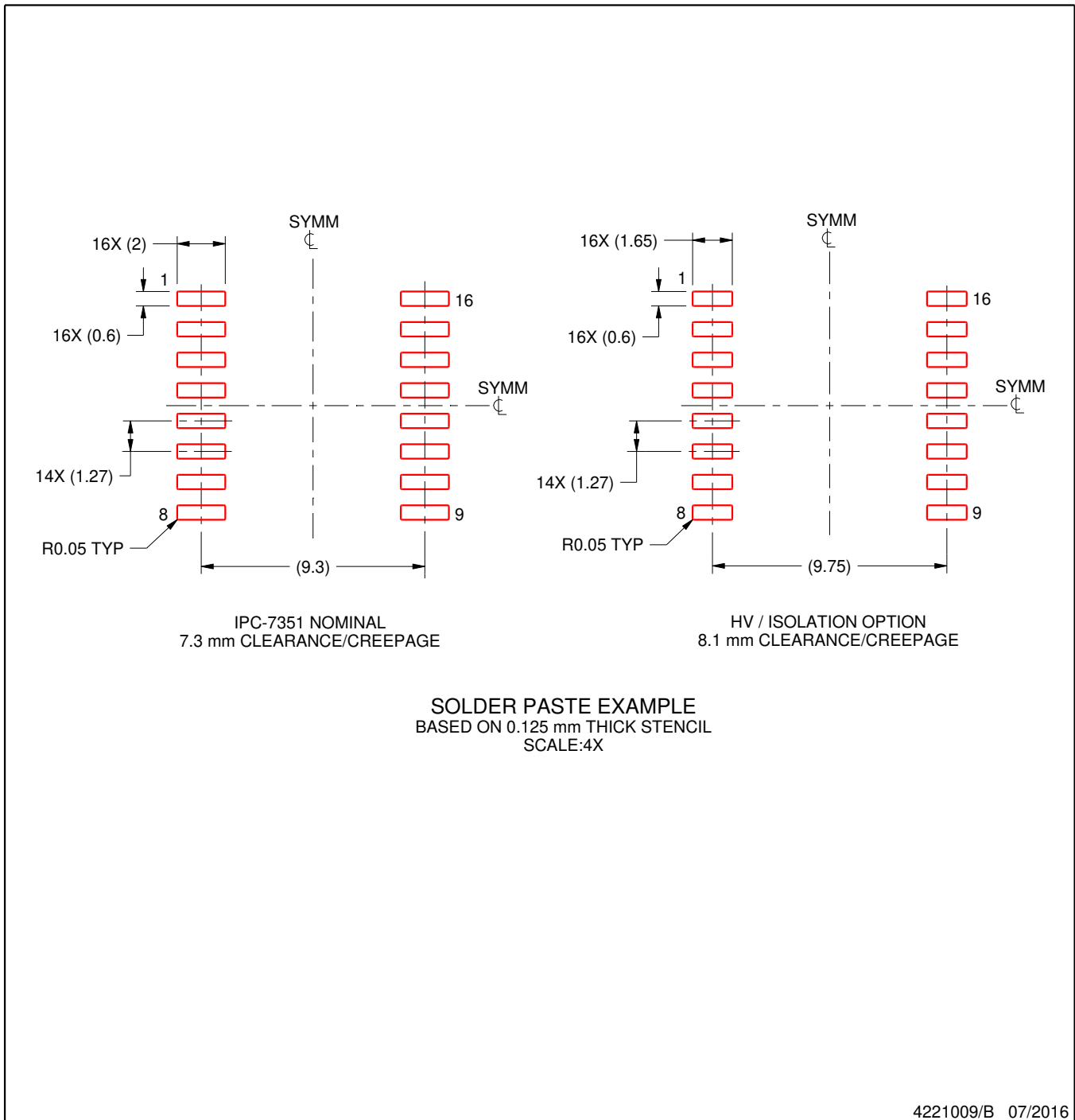

NOTES: (continued)

8. Laser cutting apertures with trapezoidal walls and rounded corners may offer better paste release. IPC-7525 may have alternate design recommendations.
9. Board assembly site may have different recommendations for stencil design.

DWW0016A



# PACKAGE OUTLINE

## SOIC - 2.65 mm max height

PLASTIC SMALL OUTLINE

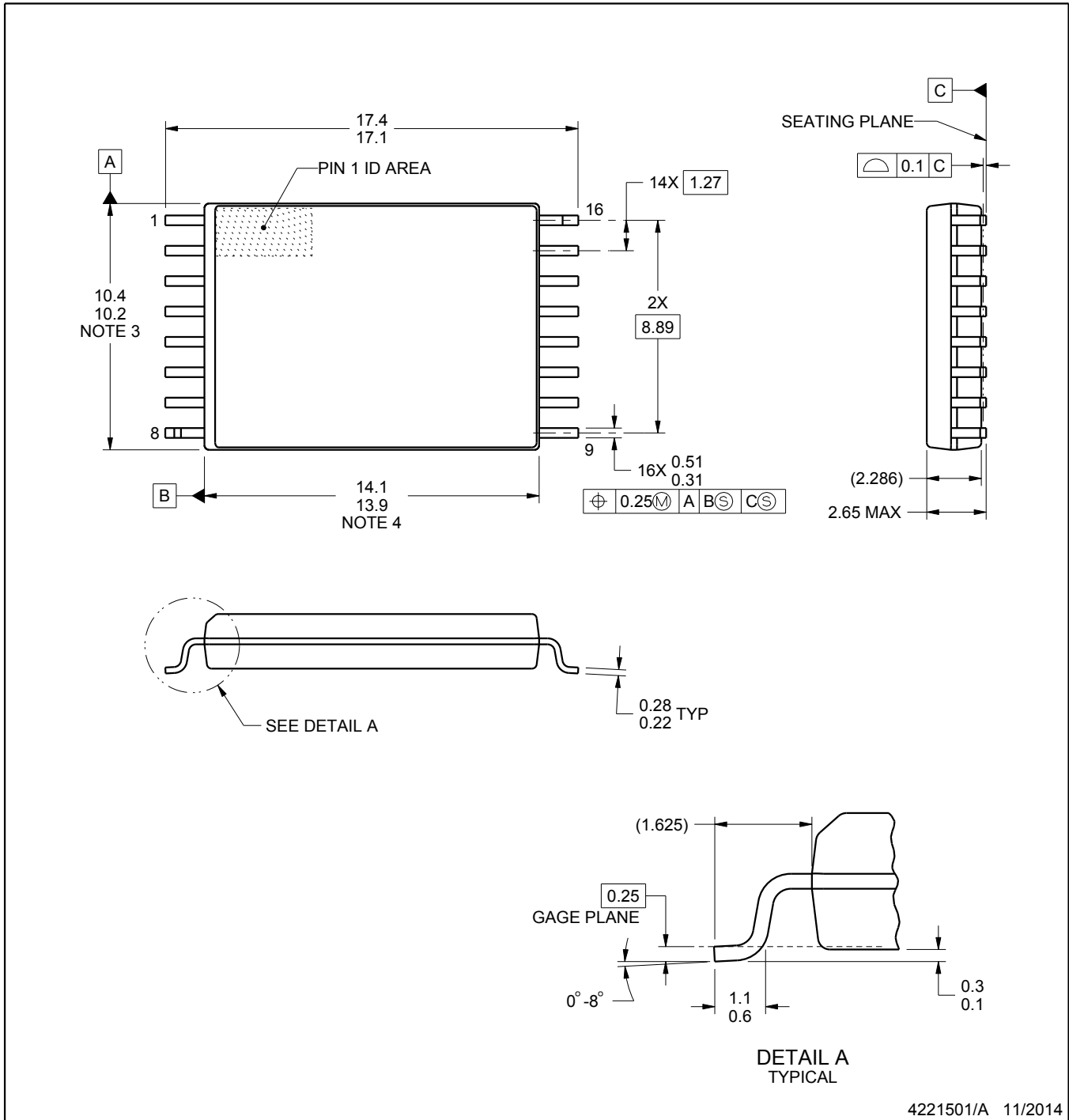

4221501/A 11/2014

NOTES:

1. All linear dimensions are in millimeters. Any dimensions in parenthesis are for reference only. Dimensioning and tolerancing per ASME Y14.5M.
2. This drawing is subject to change without notice.
3. This dimension does not include mold flash, protrusions, or gate burrs. Mold flash, protrusions, or gate burrs shall not exceed 0,15 mm per side.
4. This dimension does not include interlead flash.

# EXAMPLE BOARD LAYOUT

DWW0016A

SOIC - 2.65 mm max height

PLASTIC SMALL OUTLINE

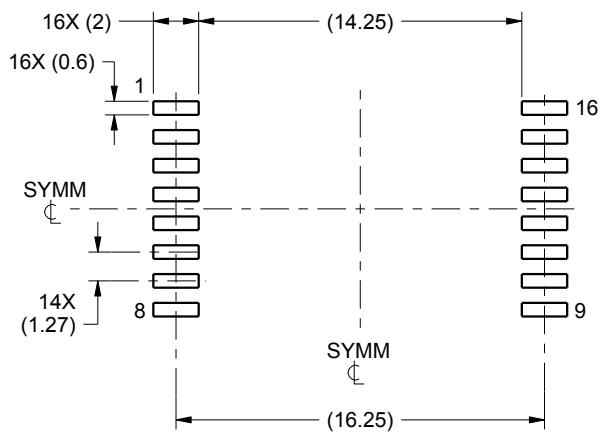

LAND PATTERN EXAMPLE  
STANDARD  
SCALE:3X

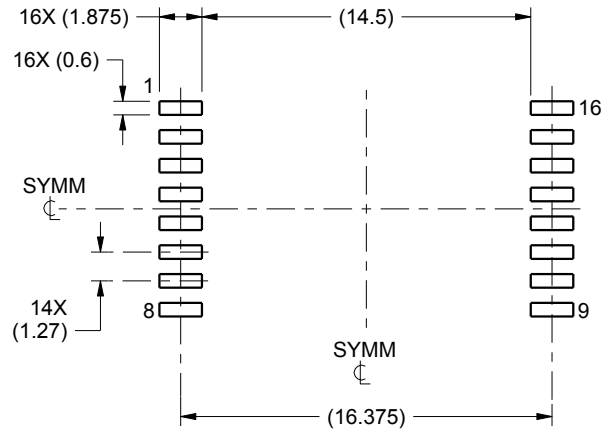

LAND PATTERN EXAMPLE  
PCB CLEARANCE & CREEPAGE OPTIMIZED  
SCALE:3X

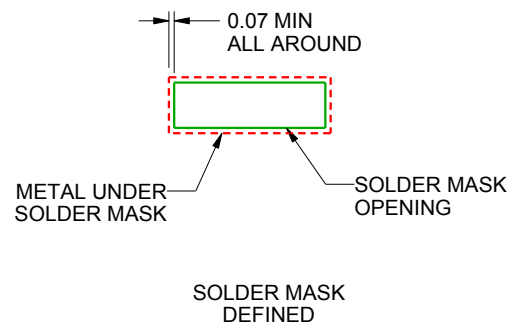
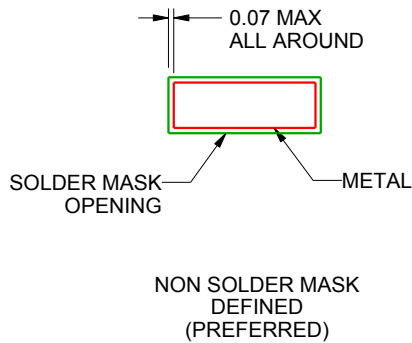

SOLDER MASK DETAILS

4221501/A 11/2014

NOTES: (continued)

5. Publication IPC-7351 may have alternate designs.
6. Solder mask tolerances between and around signal pads can vary based on board fabrication site.

# EXAMPLE STENCIL DESIGN

DWW0016A

SOIC - 2.65 mm max height

PLASTIC SMALL OUTLINE

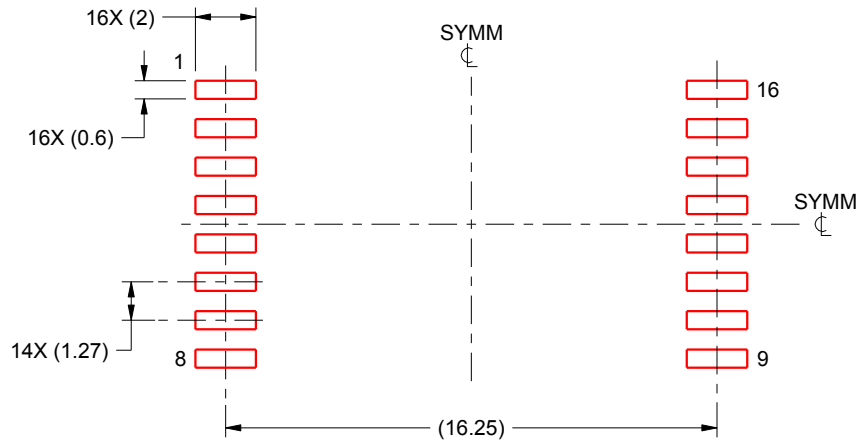

SOLDER PASTE EXAMPLE  
STANDARD  
BASED ON 0.125 mm THICK STENCIL  
SCALE:4X

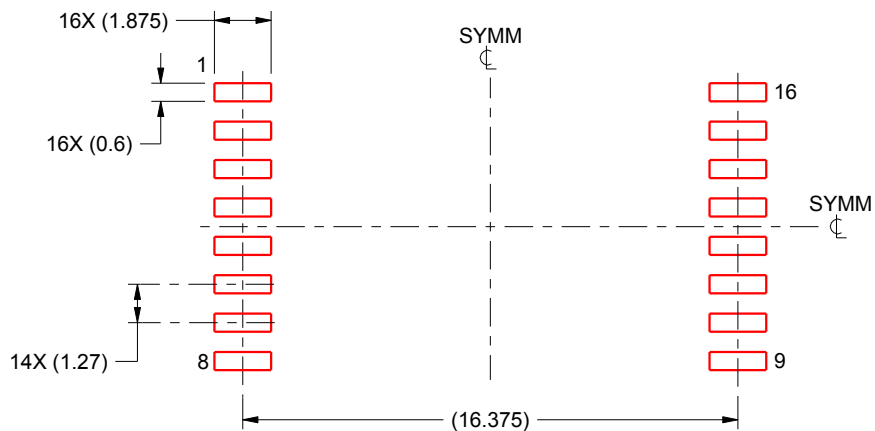

SOLDER PASTE EXAMPLE  
PCB CLEARANCE & CREEPAGE OPTIMIZED  
BASED ON 0.125 mm THICK STENCIL  
SCALE:4X

4221501/A 11/2014

NOTES: (continued)

7. Laser cutting apertures with trapezoidal walls and rounded corners may offer better paste release. IPC-7525 may have alternate design recommendations.
8. Board assembly site may have different recommendations for stencil design.

## IMPORTANT NOTICE AND DISCLAIMER

TI PROVIDES TECHNICAL AND RELIABILITY DATA (INCLUDING DATA SHEETS), DESIGN RESOURCES (INCLUDING REFERENCE DESIGNS), APPLICATION OR OTHER DESIGN ADVICE, WEB TOOLS, SAFETY INFORMATION, AND OTHER RESOURCES "AS IS" AND WITH ALL FAULTS, AND DISCLAIMS ALL WARRANTIES, EXPRESS AND IMPLIED, INCLUDING WITHOUT LIMITATION ANY IMPLIED WARRANTIES OF MERCHANTABILITY, FITNESS FOR A PARTICULAR PURPOSE OR NON-INFRINGEMENT OF THIRD PARTY INTELLECTUAL PROPERTY RIGHTS.

These resources are intended for skilled developers designing with TI products. You are solely responsible for (1) selecting the appropriate TI products for your application, (2) designing, validating and testing your application, and (3) ensuring your application meets applicable standards, and any other safety, security, regulatory or other requirements.

These resources are subject to change without notice. TI grants you permission to use these resources only for development of an application that uses the TI products described in the resource. Other reproduction and display of these resources is prohibited. No license is granted to any other TI intellectual property right or to any third party intellectual property right. TI disclaims responsibility for, and you will fully indemnify TI and its representatives against, any claims, damages, costs, losses, and liabilities arising out of your use of these resources.

TI's products are provided subject to [TI's Terms of Sale](#) or other applicable terms available either on [ti.com](http://ti.com) or provided in conjunction with such TI products. TI's provision of these resources does not expand or otherwise alter TI's applicable warranties or warranty disclaimers for TI products.

TI objects to and rejects any additional or different terms you may have proposed.

Mailing Address: Texas Instruments, Post Office Box 655303, Dallas, Texas 75265  
Copyright © 2022, Texas Instruments Incorporated