

Top View of Assembly

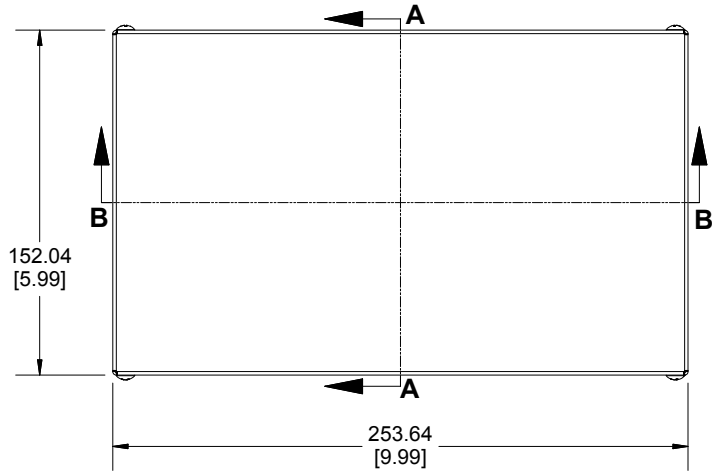

**SECTION A-A
End View of Assembly**

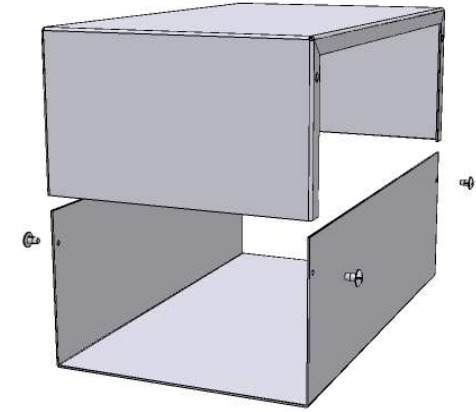
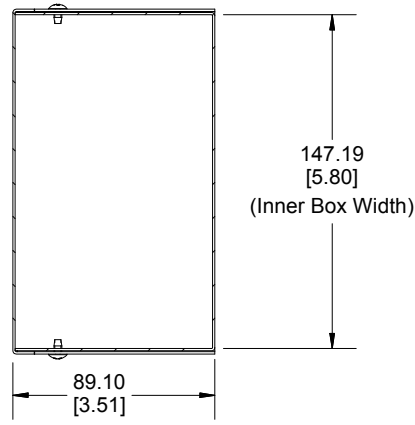

**SECTION B-B
Side View of Assembly**

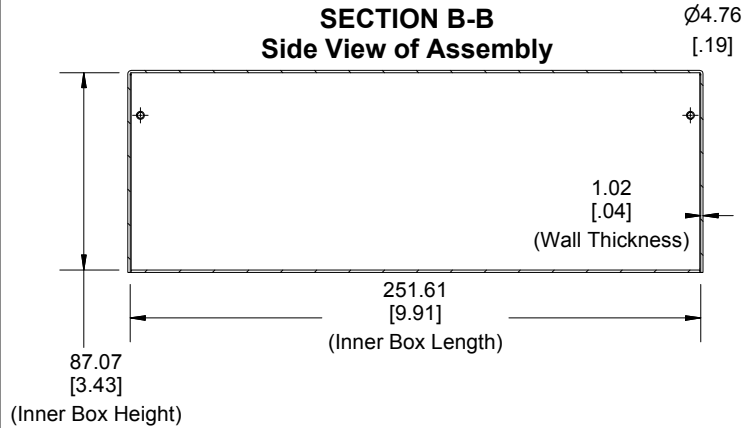

Cover

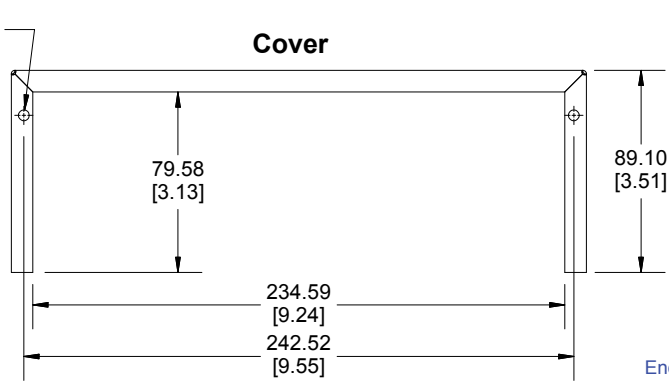

Enclosures can be Factory Modified (Milling, Drilling, Printing etc.)
Contact Factory mjm@hammondmfg.com for quotes
Solid models of this enclosure available in STEP or IGES.

Bottom

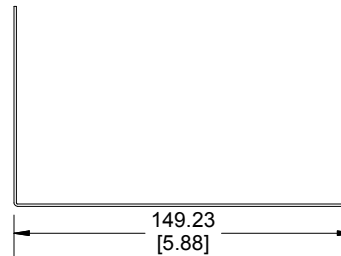
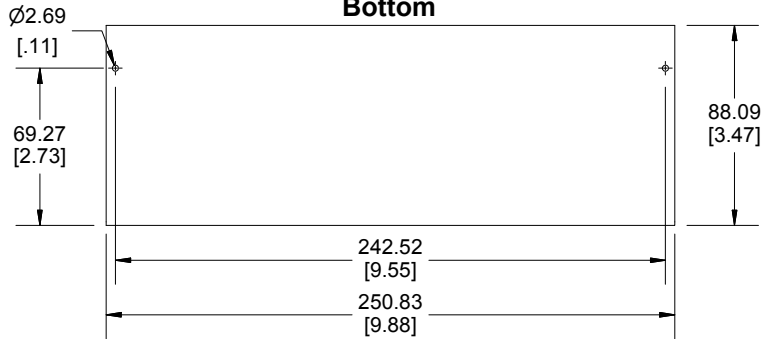

NOTE

Purchased assembly includes bottom, cover and 4 cover screws.
Bottom and cover are made from 0.04" Aluminum Panels.

PART NUMBERS

1411U Enclosure	
Natural Finish Enclosure	1411UU
ASA 61 Grey Enclosure	1411U
ACCESSORIES	
Plated Cover Screws (Pkg 6) [6-32 x 1/4" Self-Tapping Screws]	1421J6

**HAMMOND
MANUFACTURING™**

1411U

www.hammondmfg.com

Dimensions:
mm
[inches]