

PART NUMBER	REVISION	DESCRIPTION	FEED TYPE
2151610-1	E	FINE CRIMP HEIGHT ADJUST	MECHANICAL
2151610-2	F	FINE CRIMP HEIGHT ADJUST	PNEUMATIC
7-2151610-1	E	MECHANICAL AND CRIMP TOOLING KIT	MECHANICAL
7-2151610-2	F	PNEUMATIC AND CRIMP TOOLING KIT	PNEUMATIC
7-2151610-7	D	CRIMP TOOLING KIT	-

ATLANTIC VERSION TERMINATOR INTERFACE ADAPTER



APPLICATOR DATA		
CRIMP	SIZE	TYPE
WIRE	2.59 mm [.102]	F
INSUL	5.00 mm [.197]	F

APPLICATOR INSTRUCTIONS 408-35042

TERMINAL DATA: DELPHI PACKARD TERMINAL DELPHI CRIMP SPECIFICATIONS	
TERMINAL NAME: TAXI TERM GT 280 SEALED	
WIRE STRIP LENGTH 5.22-5.98 mm [.206-.235 IN]	TERMINAL INSULATION DIAMETER RANGE 2.20-3.20 mm [.087-.126 IN]
TERMINAL APPLICATION SPECIFICATION DELPHI CRIMP INFO SHEET 15304720 P.8 Rev 2014-07-29	

TERMINALS APPLIED				SEAL INSULATION DIAMETER RANGE
TE TERMINAL	DELPHI PACKARD TERMINAL	TE SEAL	DELPHI PACKARD SEAL	
1572758-1	15304732	1572498-1	15366066	1.86-2.40 mm
1572491-1	15304720	1949092-1	15324985	1.60-2.15 mm
		1949807-1	15324982	2.03-2.85 mm
		1572759-1	15366067	2.50-3.20 mm

WIRE SIZE	CRIMP HEIGHT mm [INCH]	CRIMP HEIGHT REFERENCE SETTING
3.00mm2	2.05 +/- 0.05 [.081 +/- .002]	5.0
2.50mm2	1.90 +/- 0.05 [.075 +/- .002]	6.5
2.00mm2	1.70 +/- 0.05 [.067 +/- .002]	8.9
1.50mm2	1.60 +/- 0.05 [.063 +/- .002]	9.9

- 1 RECOMMENDED SPARE PARTS
- 2 REFER TO SUPPLIED INSTRUCTION SHEET FOR CLEANING, LUBRICATION AND STORAGE OF APPLICATOR.
- 3 APPLY PART NUMBER 2-23419-6 LOCTITE TO THREADS OF ITEM 242.
- 4 CRIMP HEIGHT REFERENCE SETTING WAS THE SETTING USED WHEN THE APPLICATOR WAS QUALIFIED AT THE FACTORY. ADJUSTMENT MAY BE NECESSARY WHEN RUNNING APPLICATOR IN THE FIELD.
- 5 APPLY TORO-SEAL IN ALLEN SOCKET TO FILL HOLE AFTER FLAT HD HAS BEEN ADJUSTED TO CORRECT HEIGHT AT QUALIFICATION. APPLY #1-23419-5 LOC-TITE TO THREADS.
- 6. UNLESS SPECIFIED OTHERWISE TORQUE VALUES SHALL BE USED PER DOCUMENT, 101-35000.
- 7 TERMINAL SUPPORT LOCATION 4.1±0.5 FOR TERMINAL 15304732.
- 8 TERMINAL SUPPORT LACTION 2.3±0.5 FOR TERMINAL 15304720.

***WARNING**
ON INSTALLATION, SET WIRE DISC TO CRIMP HEIGHT REFERENCE SETTING FOR LARGEST WIRE SIZE. CRIMP HEIGHT REFERENCE SETTINGS GREATER THAN THE VALUE SHOWN MAY CAUSE DAMAGE TO THE CRIMP TOOLING. REFER TO THE INSTRUCTION SHEET FOR PROPER SETUP AND ADJUSTMENTS.

LOC	DIST	REVISIONS					
A	66	P	LTN	DESCRIPTION	DATE	OWN	APVD
		C		ECR-16-013350	19SEP2016	TB	TE
		D		ECR-17-002229	16FEB2017	TB	CT
		E		ECR-18-017047	29OCT2018	MZ	KZ
		F		ECR-22-128765	07FEB2022	FZ	RK

-	1	-	1	-	2119641-1	FEED CAM, AIR FEED	248
-	1	1	1	1	2119082-7	CAM, SNAIL, INSULATION ADJUSTMENT	244
-	1	1	1	1	2079764-1	WASHER, WAVE SPRING, CREST-TO-CREST	243
-	1	1	1	1	2119083-1	RETAINER, INSULATION DIAL	242
-	1	1	1	1	7-18023-7	SCR, SKT HD CAP M3 X 4.0	241
-	-	1	-	1	2119580-1	MECHANICAL FEED ASSEMBLY	239
-	1	-	1	-	2844940-1	AIR FEED MODULE	238
-	REF	REF	REF	REF	994970-2	COUNTER, MAGNETIC	164
-	1	1	1	1	2844908-1	SCREW, LOCKING	99
-	1	1	1	1	2844907-1	POST, LOCKING	98
-	1	1	1	1	455888-5	SPACER, CRIMPER	82
-	1	1	1	1	1803607-3	DOCUMENTATION PACKAGE	71
-	1	1	1	1	2119791-9	DEPRESSOR, WIRE	70
-	1	1	1	1	2119943-1	WASHER, SPACER	69
-	1	1	1	1	2119740-1	TAG, IDENTIFICATION	67
-	2	2	2	2	2168078-1	SCREW, DRIVE, RH, RoHS, 2 x .188	66
-	1	1	1	1	2168083-2	SCR, SKT HD CAP, RoHS, M4 X 8.0	60
-	1	1	1	1	5-18022-5	SCR, HEX HD CAP, M4 X 6.0	59
-	1	1	1	1	985575-3	SCR, FLT SKT HD CAP M3 X 10.0	57
-	1	1	1	1	1338685-1	PAWL, FEED	56
-	4	4	4	4	2168083-3	SCR, SKT HD CAP, RoHS, M4 X 12.0	54
-	2	2	2	2	1-2168083-0	SCR, SKT HD CAP, RoHS, M4 X 10	53
-	1	1	1	1	1803382-6	HOLD DOWN, SPRING LOADED	50
-	1	2	1	2	18023-9	SCR, SKT HD CAP M4 X 6.0	49
-	-	1	-	1	2119652-1	FEED CAM, PRE FEED	48
-	-	1	-	1	2119653-1	FEED CAM, POST FEED	47
-	1	1	1	1	1803583-9	APPLICATOR BASIC ASSEMBLY, SF	46
-	1	1	1	1	1803515-1	RAM ASSEMBLY, SF ATLANTIC	44
-	1	1	1	1	1803602-1	SCR, BHSC, RoHS (M8 X 25)	41
-	1	1	1	1	1752356-1	SUPPORT, TERMINAL	34
-	2	2	2	2	1-2079383-3	SCR, BHSC, RoHS (M4 X 25)	33
-	2	2	2	2	3-2844962-5	SPACER, CYLINDRICAL, STRIP GUIDE	30
-	1	1	1	1	2844992-1	ASSEMBLY, STRIP GUIDE	29
-	1	1	1	1	1-455888-0	SPACER, CRIMPER	28
-	1	1	1	1	1320928-6	STRIP GUIDE	24
-	1	1	1	1	2168083-2	SCR, SKT HD CAP, RoHS, M4 X 8.0	21
-	2	2	2	2	1-18028-2	WASHER, FLAT, REG M4	20
-	1	1	1	1	2119533-1	STRIPPER, SIDE FEED	19
-	1	1	1	1	2119806-1	INSERT, SHEAR	13
-	1	1	1	1	3-22280-3	SPRING, COMPRESSION	12
-	1	1	1	1	1-356885-4	STOP, SHEAR	11
-	1	1	1	1	2119805-1	SHEAR HOLDER, FRONT	10
-	1	1	1	1	318707-1	FLOATING SHEAR, FRONT	9
1	2	2	1	1	7-1633928-5	ANVIL, COMBINATION	8
-	-	-	-	-	-	-	7
-	-	-	-	-	-	-	6
-	1	1	1	1	2119781-1	DEPRESSOR, SHEAR	5
-	1	1	1	1	4-238011-5	BLOCK, CRIMPER SPACER	4
1	2	2	1	1	4-1803248-3	CRIMPER, INSULATION O PREMIUM	3
-	-	-	-	-	-	-	2
1	2	2	1	1	1633588-6	CRIMPER, WIRE	1
-	77	-72	-71	-2	-1	PART NO	ITEM NO

ATLANTIC VERSION
Shown on sheets 1 of 4 & 2 of 4
(Pacific version shown on sheets 3 of 4 & 4 of 4)

DIMENSIONS:		TOLERANCES UNLESS OTHERWISE SPECIFIED:		MATERIAL:		FINISH:		WEIGHT:		SCALE:		SHEET:		REV:	
mm	0 PLC ±	1 PLC ±	2 PLC ±	3 PLC ±	4 PLC ±	ANGLES	FINISH			A1	00779	C=2151610	1	4	F

Customer Accessible Production Drawing

LOC	DIST	REVISIONS					
A	66	P	LYR	DESCRIPTION	DATE	OWN	APVD
		-		SEE SHEET 1	-	-	-

FEED TYPE MECHANICAL

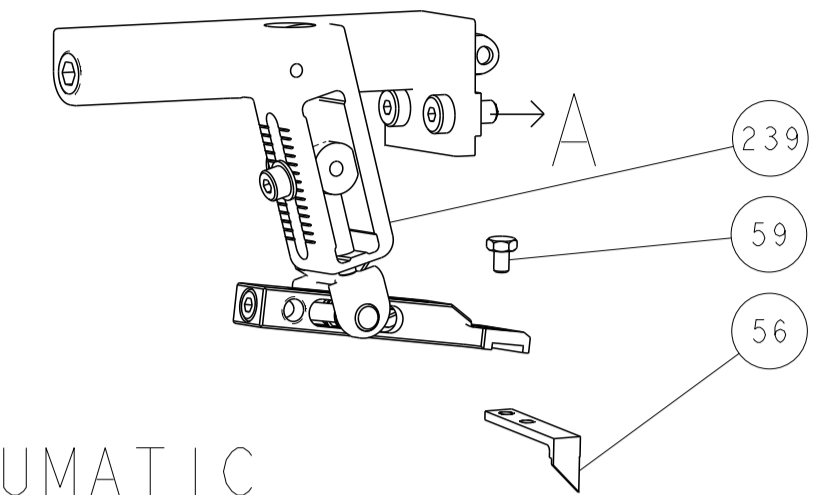

PNEUMATIC

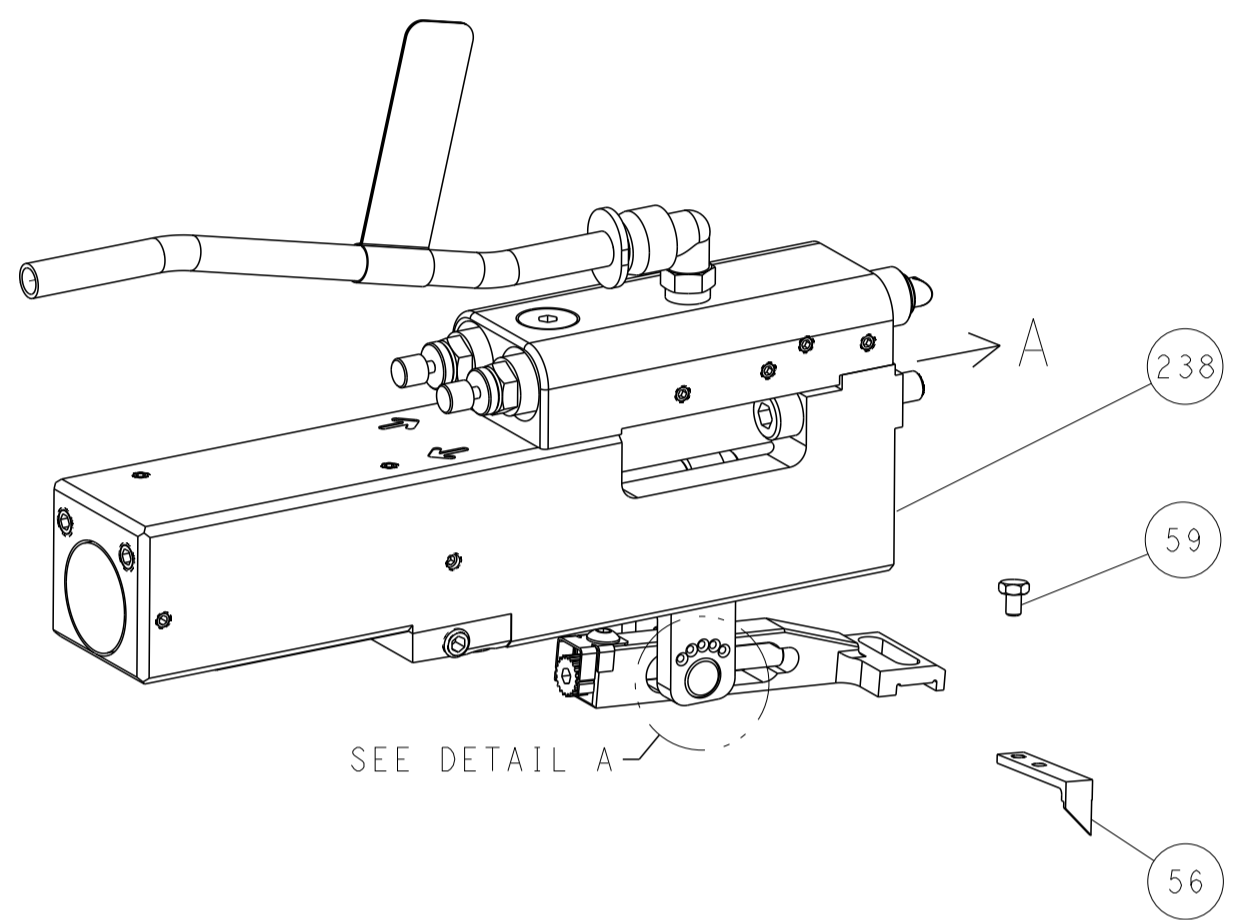

FEED SPRING SETTING POSITION (SHOWN FROM REAR SIDE)



DETAIL A

CAM POSITIONS

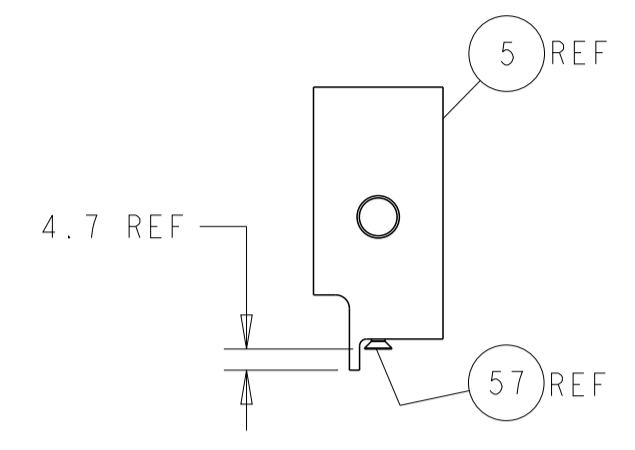
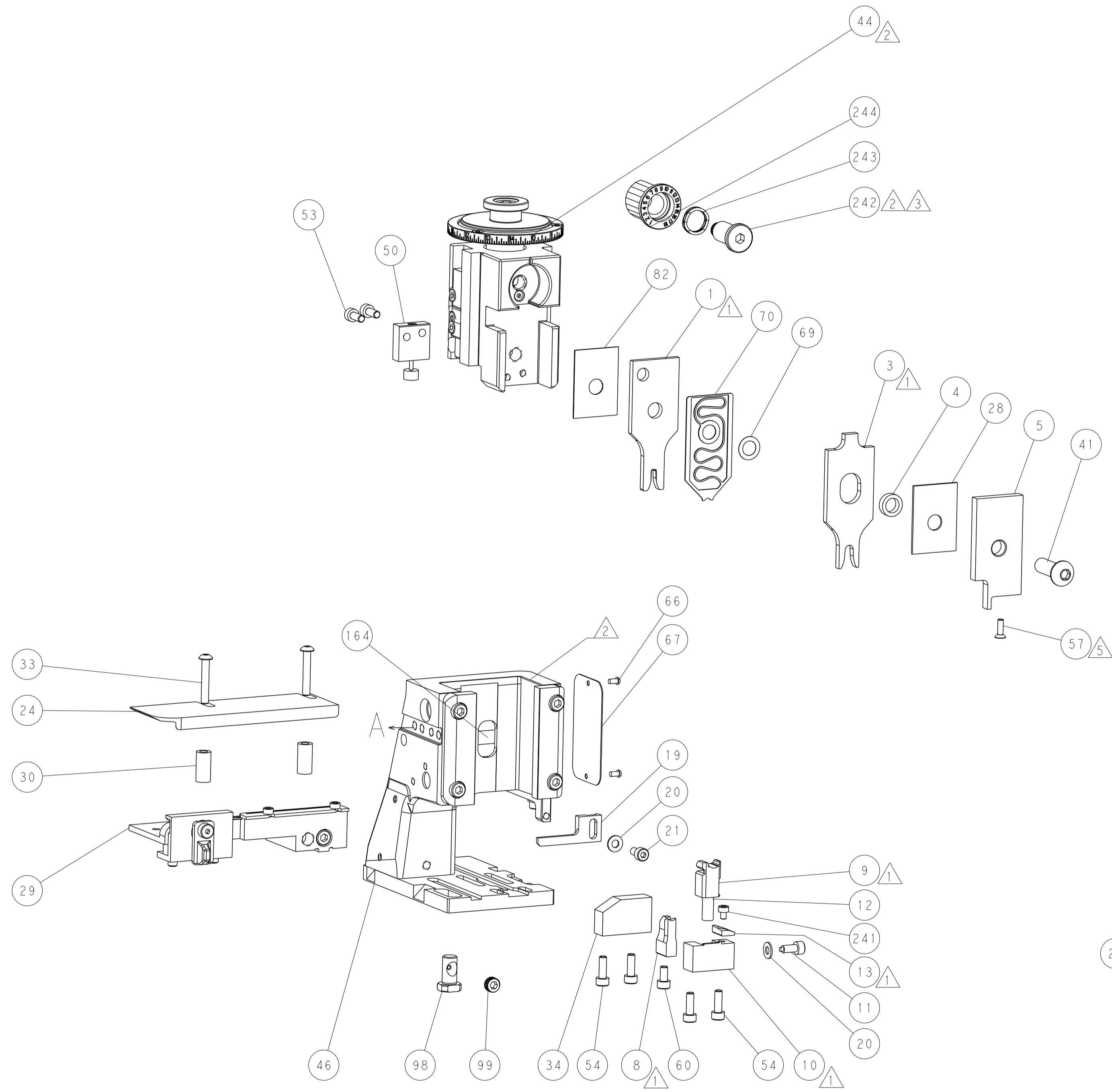
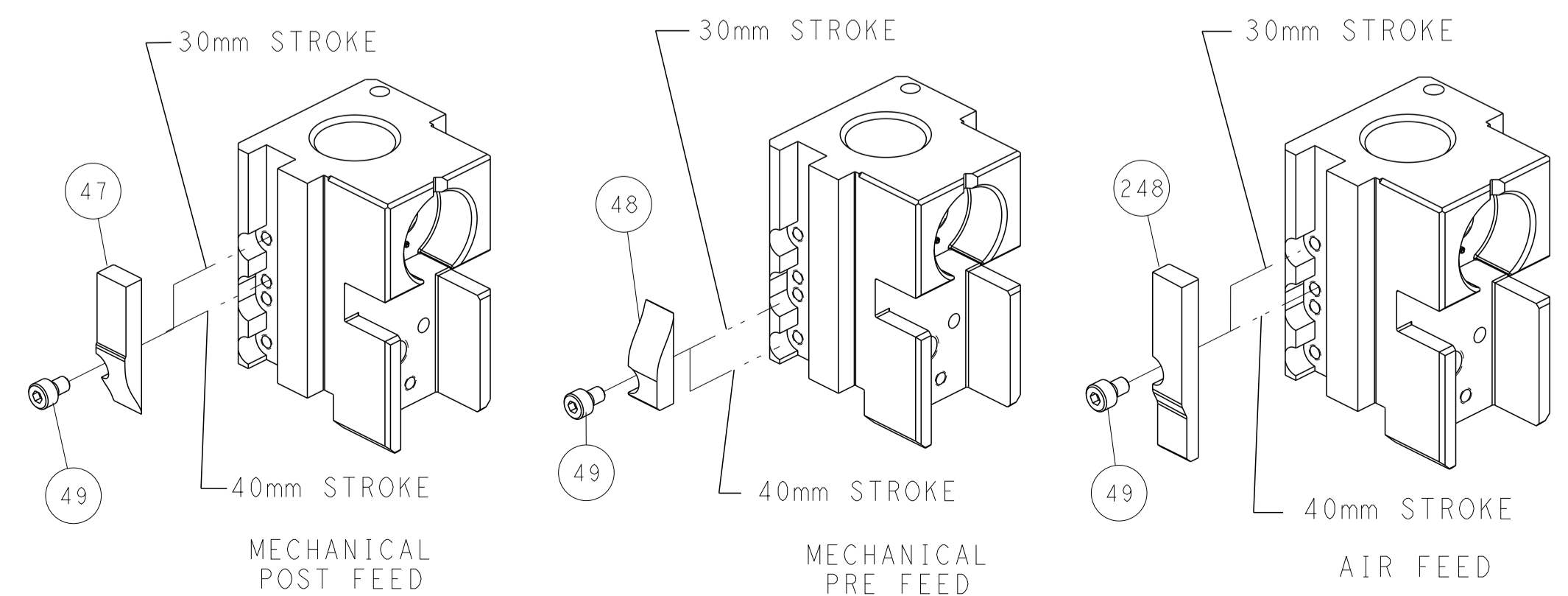

SHEAR DEPRESSOR DETAIL

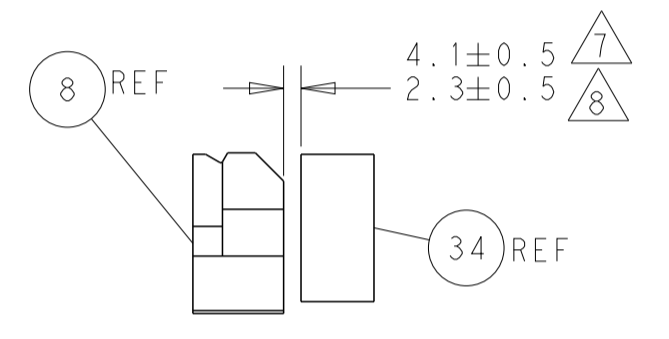

TERMINAL SUPPORT LOCATION

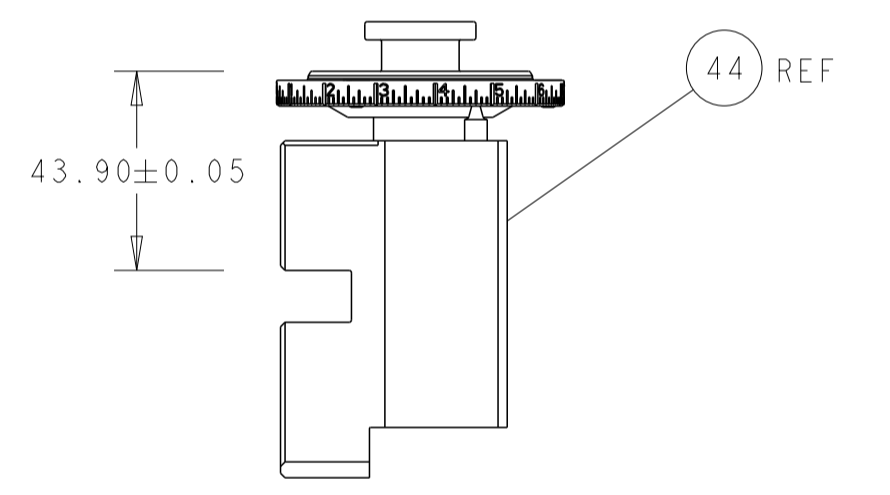

RAM SET-UP

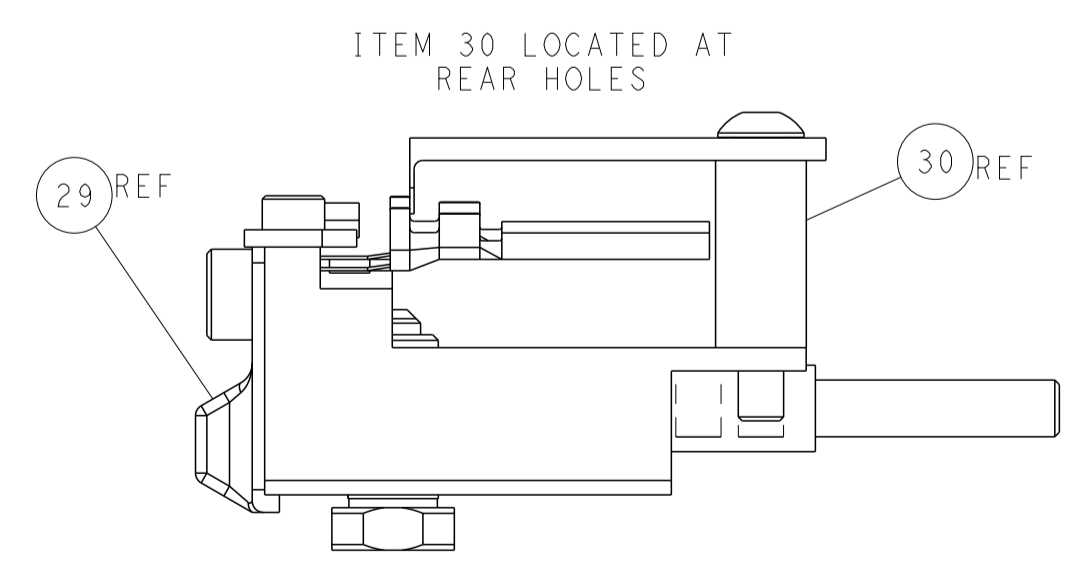

FEED TRACK POSITION GUIDE BY INSULATION BARREL

ATLANTIC VERSION
 Shown on sheets 1 of 4 & 2 of 4
 (Pacific version shown on sheets 3 of 4 & 4 of 4)

<small>THIS DRAWING IS UNPUBLISHED. RELEASED FOR PUBLICATION BY TYCO ELECTRONICS CORPORATION. ALL RIGHTS RESERVED.</small>		DWN BOB HIGMAN 08MAR2012 CHK T. ELBIN 08MAR2012 APVD M. CLIFFORD 08MAR2012	TE Connectivity Harrisburg, PA 17105-3608
DIMENSIONS: mm TOLERANCES UNLESS OTHERWISE SPECIFIED: 0 PLC ± 1 PLC ± 2 PLC ± 3 PLC ± 4 PLC ± ANGLES ±		NAME Ocean Side Feed Applicator PRODUCT SPEC APPLICATION SPEC WEIGHT SCALE 1:2	SIZE CAGE CODE DRAWING NO RESTRICTED TO A1 00779 C=2151610 SHEET 2 OF 4 REV F
MATERIAL: . FINISH: .		Customer Accessible Production Drawing	

PART NUMBER	REVISION	DESCRIPTION	FEED TYPE
2-2151610-1	E	FINE CRIMP HEIGHT ADJUST	MECHANICAL
2-2151610-2	F	FINE CRIMP HEIGHT ADJUST	PNEUMATIC
7-2151610-7	D	CRIMP TOOLING KIT	-

PACIFIC VERSION TERMINATOR
 INTERFACE ADAPTER



APPLICATOR DATA		
CRIMP	SIZE	TYPE
WIRE	2.59 mm [.102]	F
INSUL	5.00 mm [.197]	F

APPLICATOR INSTRUCTIONS
 408-35042

TERMINAL DATA: DELPHI PACKARD TERMINAL	DELPHI CRIMP SPECIFICATION
TERMINAL NAME: TAXI TERM GT 280 SEALED	
WIRE STRIP LENGTH 5.22-5.98 mm [1.206-.235 IN]	TERMINAL INSULATION DIAMETER RANGE ∅ 2.20-3.20 mm [1.087-.126 IN]
TERMINAL APPLICATION SPECIFICATION	DELPHI CRIMP INFO SHEET 15304720 P.8 Rev 2014-07-29

TE TERMINAL	DELPHI PACKARD TERMINAL	TE SEAL	DELPHI PACKARD SEAL	SEAL INSULATION DIAMETER RANGE
1572758-1	15304732	1572498-1	15366066	1.86-2.40 mm
1572491-1	15304720	1949092-1	15324985	1.60-2.15 mm
		1949807-1	15324982	2.03-2.85 mm
		1572759-1	15366067	2.50-3.20 mm

WIRE SIZE	CRIMP HEIGHT mm [INCH]	CRIMP HEIGHT REFERENCE SETTING
3.00mm2	2.05 +/- 0.05 [1.081 +/- .002]	5.0
2.50mm2	1.90 +/- 0.05 [1.075 +/- .002]	6.5
2.00mm2	1.70 +/- 0.05 [1.067 +/- .002]	8.9
1.50mm2	1.60 +/- 0.05 [1.063 +/- .002]	9.9

- 1 RECOMMENDED SPARE PARTS
- 2 REFER TO SUPPLIED INSTRUCTION SHEET FOR CLEANING, LUBRICATION AND STORAGE OF APPLICATOR.
- 3 APPLY PART NUMBER 2-23419-6 LOCTITE TO THREADS OF ITEM 242.
- 4 CRIMP HEIGHT REFERENCE SETTING WAS THE SETTING USED WHEN THE APPLICATOR WAS QUALIFIED AT THE FACTORY. ADJUSTMENT MAY BE NECESSARY WHEN RUNNING APPLICATOR IN THE FIELD.
- 5 APPLY TORO-SEAL IN ALLEN SOCKET TO FILL HOLE AFTER FLAT HD HAS BEEN ADJUSTED TO CORRECT HEIGHT AT QUALIFICATION. APPLY #1-23419-5 LOC-TITE TO THREADS.
- 6. UNLESS SPECIFIED OTHERWISE TORQUE VALUES SHALL BE USED PER DOCUMENT, 101-35000.
- 7 TERMINAL SUPPORT LOCATION 4.1±0.5 FOR TERMINAL 15304732.
- 8 TERMINAL SUPPORT LOCATION 2.3±0.5 FOR TERMINAL 15304720.

***WARNING**
 ON INSTALLATION, SET WIRE DISC TO CRIMP HEIGHT REFERENCE SETTING FOR LARGEST WIRE SIZE. CRIMP HEIGHT REFERENCE SETTINGS GREATER THAN THE VALUE SHOWN MAY CAUSE DAMAGE TO THE CRIMP TOOLING, REFER TO THE INSTRUCTION SHEET FOR PROPER SETUP AND ADJUSTMENTS.

LOC	DIST	REV	DATE	BY	APPV
A	66	-	-	-	-

REV	DATE	BY	APPV	DESCRIPTION	ITEM NO	
-	1	1		2119082-7	CAM, SNAIL, INSULATION ADJUSTMENT	244
-	1	1		2079764-1	WASHER, WAVE SPRING, CREST-TO-CREST	243
3	-	1	1	2119083-1	RETAINER, INSULATION DIAL	242
-	1	1		7-18023-7	SCR, SKT HD CAP M3 X 4.0	241
-	-	1		2119580-1	MECHANICAL FEED ASSEMBLY	239
-	1	-		2844940-1	AIR FEED MODULE	238
-	REF	REF		994970-2	COUNTER, MAGNETIC	164
-	1	-		2119641-2	FEED CAM, AIR FEED	151
-	1	1		2168083-8	SCR, SKT HD CAP, RoHS, M4 X 16	144
-	4	4		2168083-9	SCR, SKT HD CAP, RoHS, M4 X 20	143
-	-	1		2119653-2	FEED CAM, POST FEED	142
-	1	1		1-1803583-0	APPLICATOR BASIC ASSEMBLY, SF	141
-	1	1		1803516-1	RAM ASSEMBLY, SF PACIFIC	140
-	1	1		2844908-1	SCREW, LOCKING	99
-	1	1		2844907-1	POST, LOCKING	98
-	1	1		455888-5	SPACER, CRIMPER	82
-	1	1		1803607-3	DOCUMENTATION PACKAGE	71
-	1	1		2119791-9	DEPRESSOR, WIRE	70
-	1	1		2119943-1	WASHER, SPACER	69
-	1	1		2119740-1	TAG, IDENTIFICATION	67
-	2	2		2168078-1	SCREW, DRIVE, RH, RoHS, 2 x .188	66
5	-	1	1	5-18022-5	SCR, HEX HD CAP, M4 X 6.0	59
-	1	1		985575-3	SCR, FLT SKT HD CAP M3 X 10.0	57
-	1	1		1338685-1	PAWL, FEED	56
-	2	2		1-2168083-0	SCR, SKT HD CAP, RoHS, M4 X 10	53
-	1	1		1803382-6	HOLD DOWN, SPRING LOADED	50
-	1	2		18023-9	SCR, SKT HD CAP M4 X 6.0	49
-	-	1		2119652-1	FEED CAM, PRE FEED	48
-	1	1		1803602-1	SCR, BHSC, RoHS (M8 X 25)	41
8, 7	-	1	1	1752356-1	SUPPORT, TERMINAL	34
-	2	2		1-2079383-3	SCR, BHSC, RoHS (M4 X 25)	33
-	2	2		3-2844962-5	SPACER, CYLINDRICAL, STRIP GUIDE	30
-	1	1		2844992-1	ASSEMBLY, STRIP GUIDE	29
-	1	1		1-455888-0	SPACER, CRIMPER	28
-	1	1		1320928-6	STRIP GUIDE	24
-	1	1		2168083-2	SCR, SKT HD CAP, RoHS, M4 X 8.0	21
-	2	2		1-18028-2	WASHER, FLAT, REG M4	20
-	1	1		2119533-1	STRIPPER, SIDE FEED	19
1	-	1	1	2119806-1	INSERT, SHEAR	13
-	1	1		3-22280-3	SPRING, COMPRESSION	12
-	1	1		1-356885-4	STOP, SHEAR	11
1	-	1	1	2119805-1	SHEAR HOLDER, FRONT	10
1	-	1	1	318707-1	FLOATING SHEAR, FRONT	9
1	1	1		7-1633928-5	ANVIL, COMBINATION	8
-	-	-		-	-	7
-	-	-		-	-	6
-	1	1		2119781-1	DEPRESSOR, SHEAR	5
-	1	1		4-238011-5	BLOCK, CRIMPER SPACER	4
1	1	1		4-1803248-3	CRIMPER, INSULATION O PREMIUM	3
-	-	-		-	-	2
1	1	1		1633588-6	CRIMPER, WIRE	1
-77	-22	-21		PART NO	DESCRIPTION	ITEM NO

PACIFIC VERSION
 Shown on sheets 3 of 4 & 4 of 4
 (Atlantic version shown on sheets 1 of 4 & 2 of 4)

DIMENSIONS: mm 		TOLERANCES UNLESS OTHERWISE SPECIFIED: 0 PLC ± 1 PLC ± 2 PLC ± 3 PLC ± 4 PLC ± ANGLES ± FINISH		OWN: BOB HIGMAN 08MAR2012 CHK: T. ELBIN 08MAR2012 APV: M. CLIFFORD 08MAR2012 PRODUCT SPEC APPLICATION SPEC WEIGHT: - SCALE: 1:2 SHEET 3 OF 4 REV F		NAME: Ocean Side Feed Applicator SIZE: A1 CAGE CODE: 00779 DRAWING NO: C=2151610 RESTRICTED TO: - Customer Accessible Production Drawing	
--------------------	--	---	--	--	--	---	--

LOC	DIST	REVISIONS					
A	66	P	LTN	DESCRIPTION	DATE	DWN	APVD
		-		SEE SHEET 1			

FEED TYPE MECHANICAL

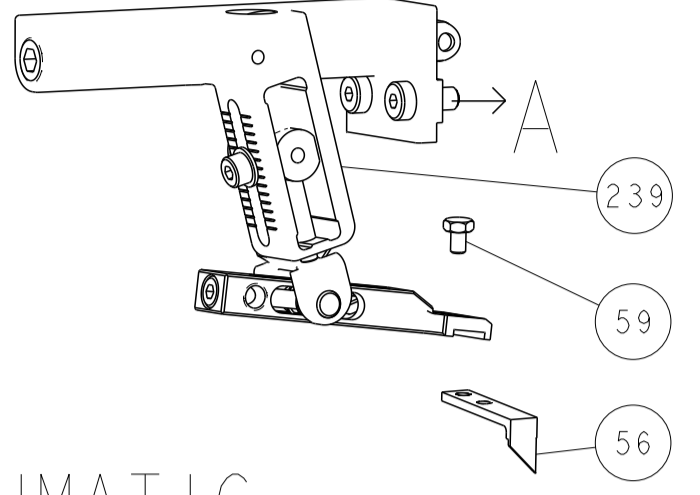

PNEUMATIC

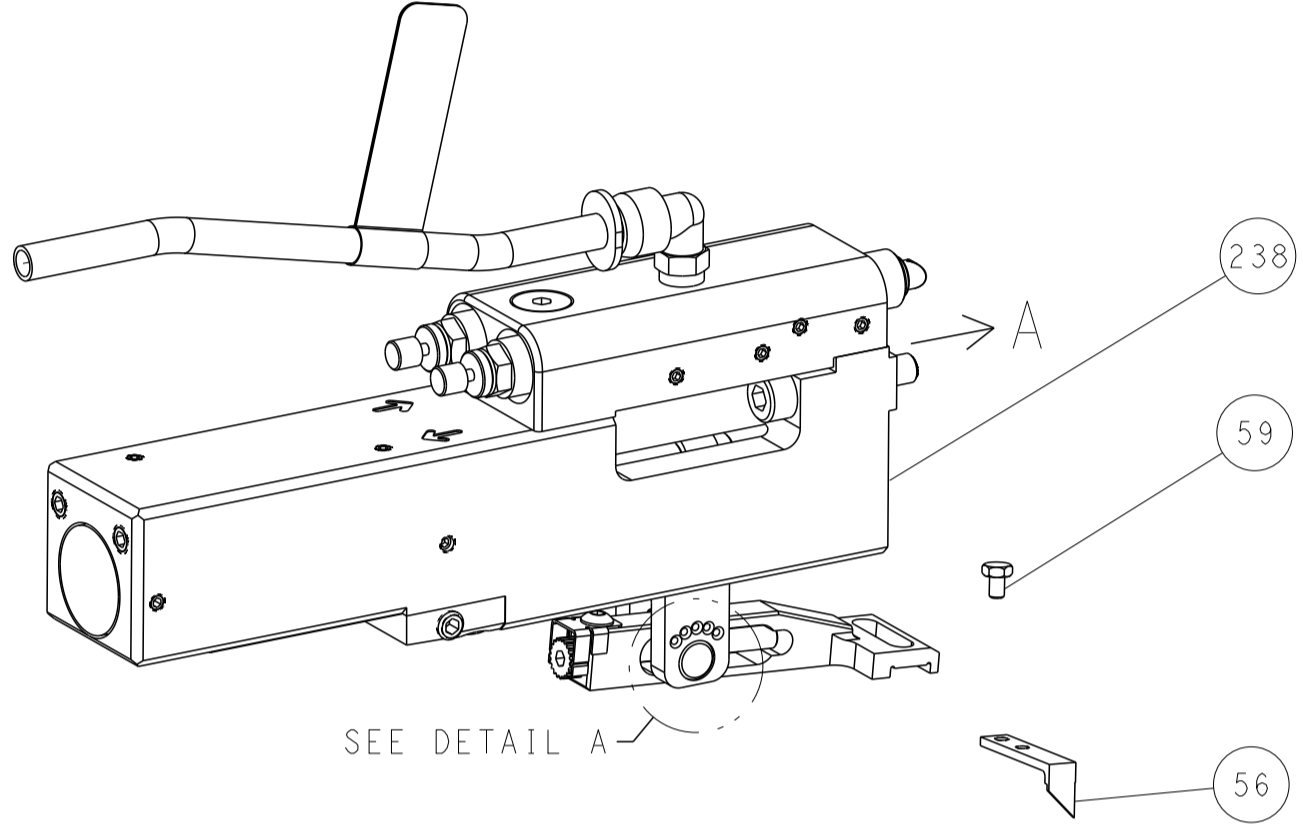

FEED SPRING SETTING POSITION (SHOWN FROM REAR SIDE)



CAM POSITIONS

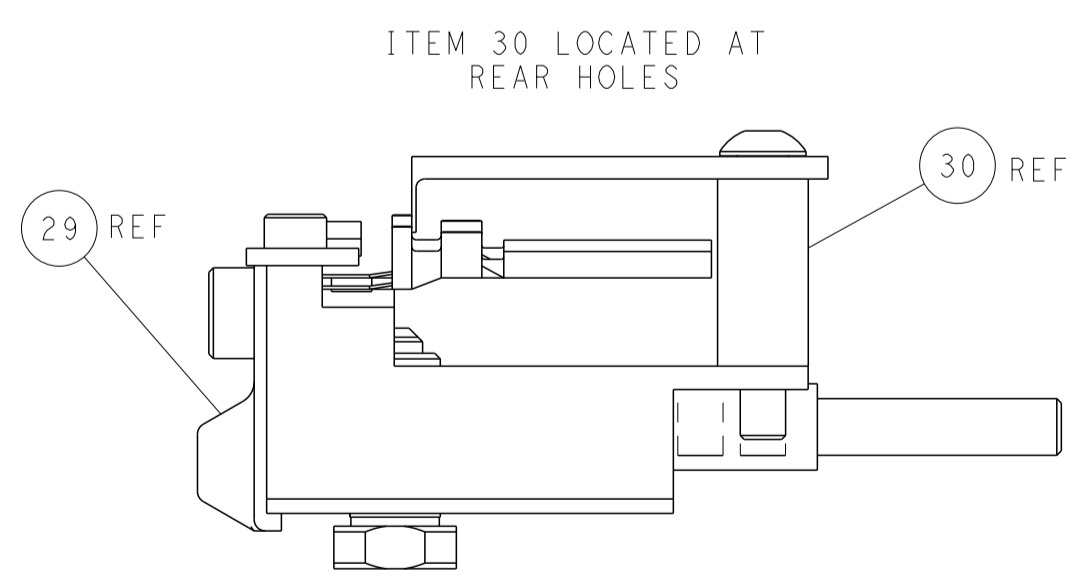
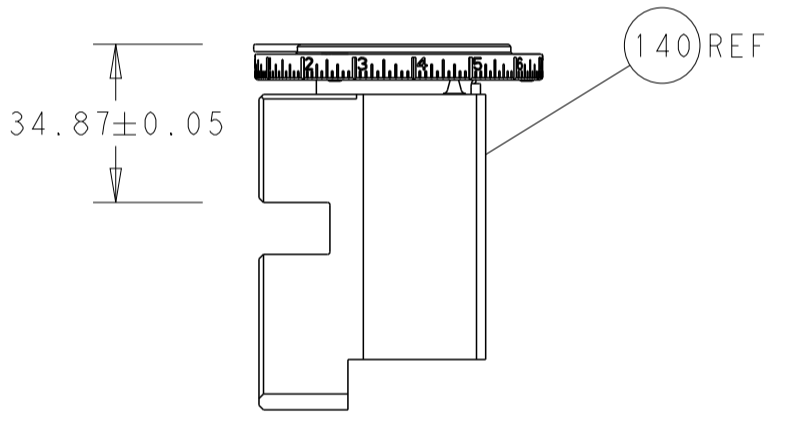
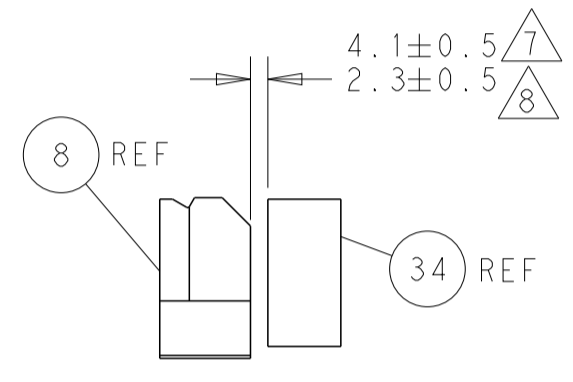
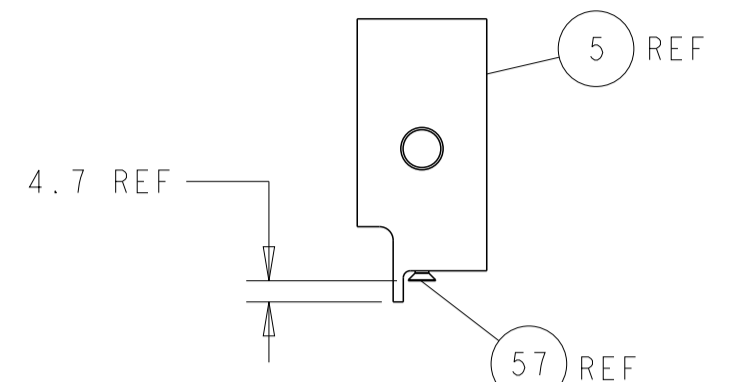
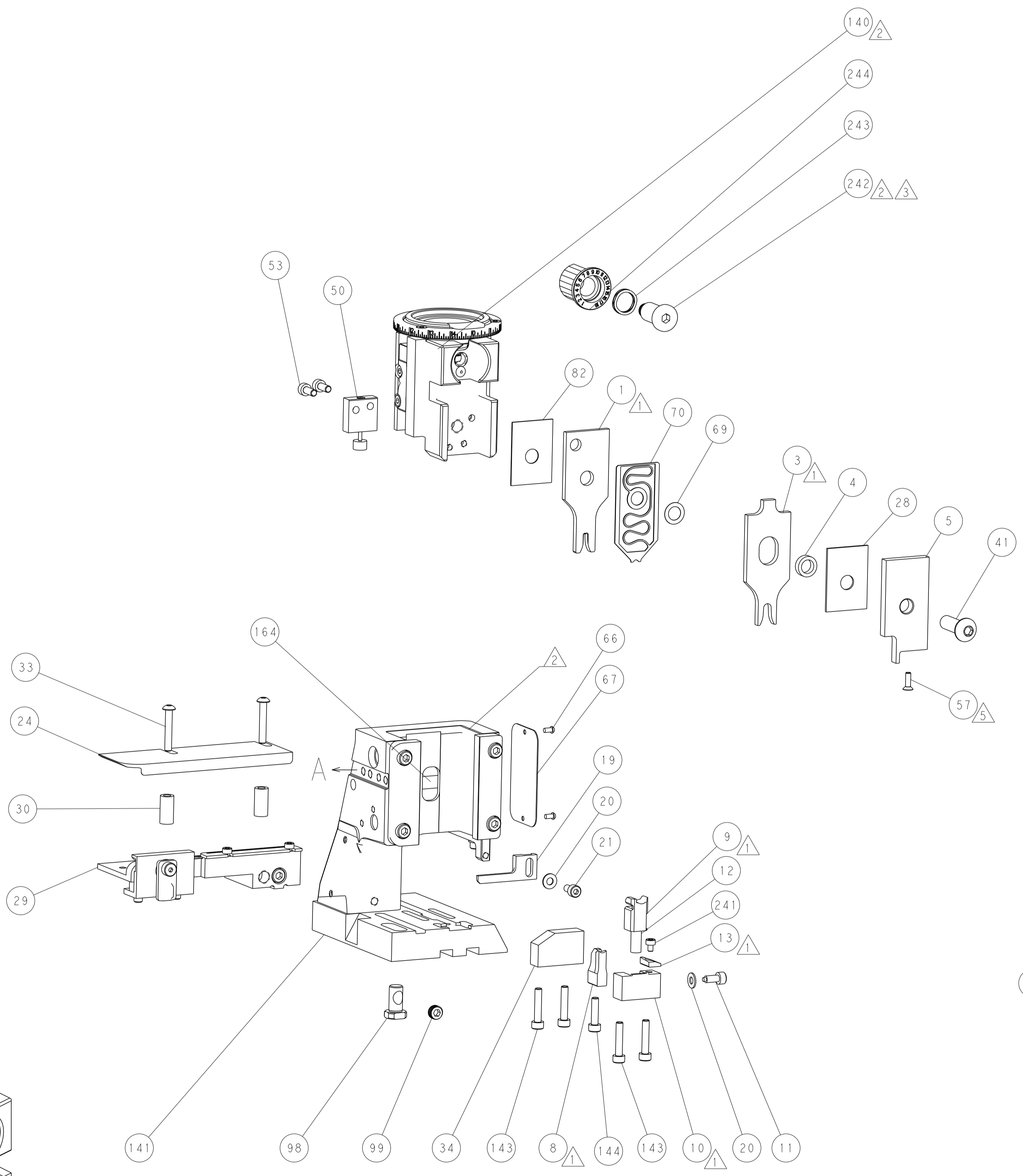
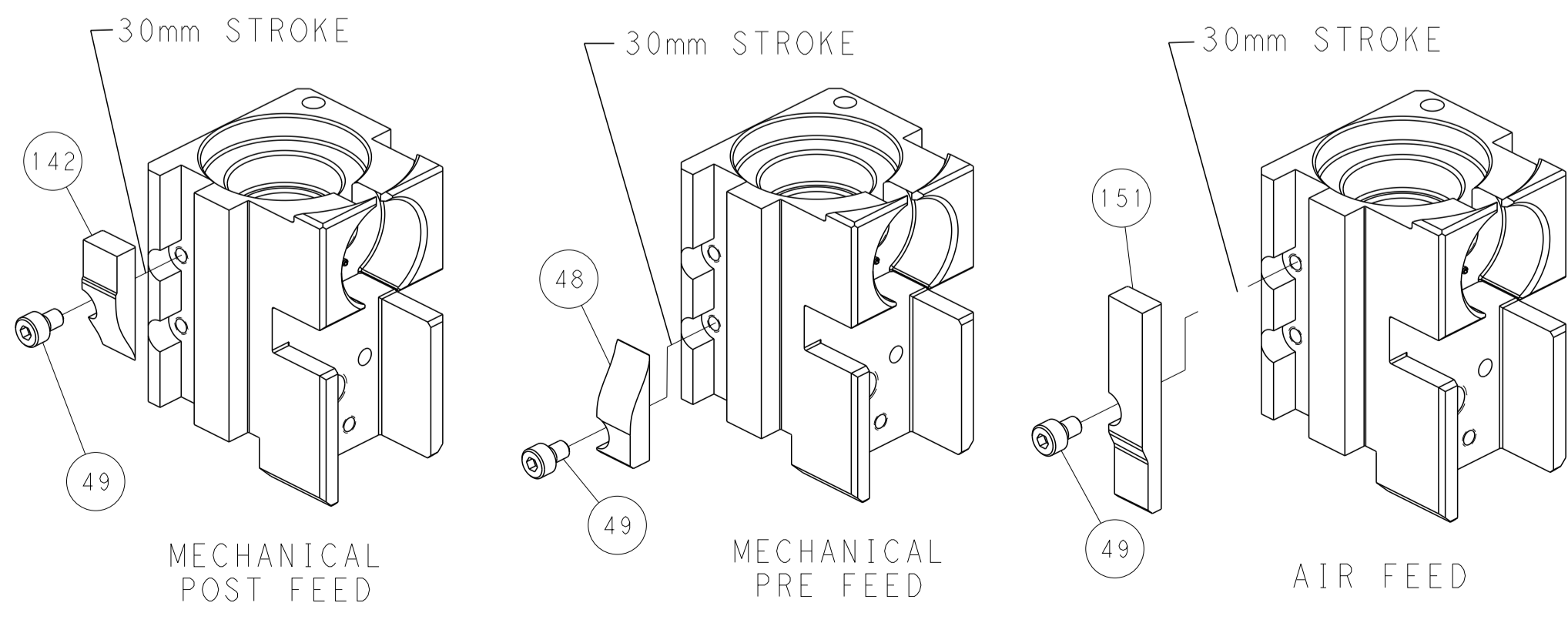

PACIFIC VERSION
 Shown on sheets 3 of 4 & 4 of 4
 (Atlantic version shown on sheets 1 of 4 & 2 of 4)

<small>THIS DRAWING IS UNPUBLISHED. RELEASED FOR PUBLICATION. ALL RIGHTS RESERVED. © 2008 BY TYCO ELECTRONICS CORPORATION.</small>		DWN BOB HIGMAN 08MAR2012 CHK T. ELBIN 08MAR2012 APVD M. CLIFFORD 08MAR2012 PRODUCT SPEC APPLICATION SPEC	NAME Ocean Side Feed Applicator
DIMENSIONS: mm 0 PLC ± 1 PLC ± 2 PLC ± 3 PLC ± 4 PLC ± ANGLES ± FINISH	TOLERANCES UNLESS OTHERWISE SPECIFIED: ± ± ± ± ± ±	SIZE CAGE CODE DRAWING NO A1 00779 C=2151610	RESTRICTED TO Customer Accessible Production Drawing SCALE 1:2 SHEET 4 OF 4 REV F