

DEMORAD

Analog Devices 24 GHz Radar Sensor Platform



Application Development on a Reference Design

The 24 GHz radar sensor platform called Demorad is a novel microwave radar evaluation platform solution with out-of-the-box software examples and easy startup of radar sensor all done within minutes.

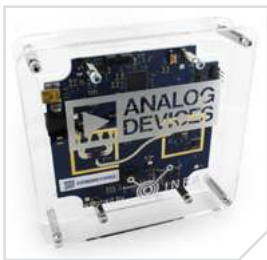

The Demorad platform enables rapid product prototyping aimed at R&D interests in investigating radar and developing radar sensor products that can measure real-time information such as target/object presence, and its movement, angular position, velocity, and range from the sensor.

The Demorad platform provides both hardware and software that allow for very fast evaluation and development of 24 GHz radar without the need to have RF microwave and signal chain system expertise, and significantly reduces development time and system expertise during product development phases.

A high performance RF and analog full signal chain including DSP processing—that is, an RF to bits solution—is provided that allows for flexible processing on raw acquisition data, allowing radar experiments on state-of-the-art level hardware in a very short time.

The Demorad platform provides full software support of 24 GHz radar ICs using a software graphical user interface (GUI) and in DSP radar support function libraries with added capability to write raw data for postprocessing on PC using MATLAB® tools.

Modular RF Front End

- ▶ Analog Devices' 24 GHz chipset
- ▶ Up to 4 analog receiver channels and MIMO

Signal Processing

- ▶ Raw data sampling and digital postprocessing

Software and Hardware

- ▶ Standardized command interface, GUI
- ▶ Real-time signal processing on Blackfin® DSP for post-processing
- ▶ USB 2.0 interface for communication
- ▶ Data rates up to 1.2 MSPS per IF channel, MIMO processing

Full Signal-Chain Technical Overview

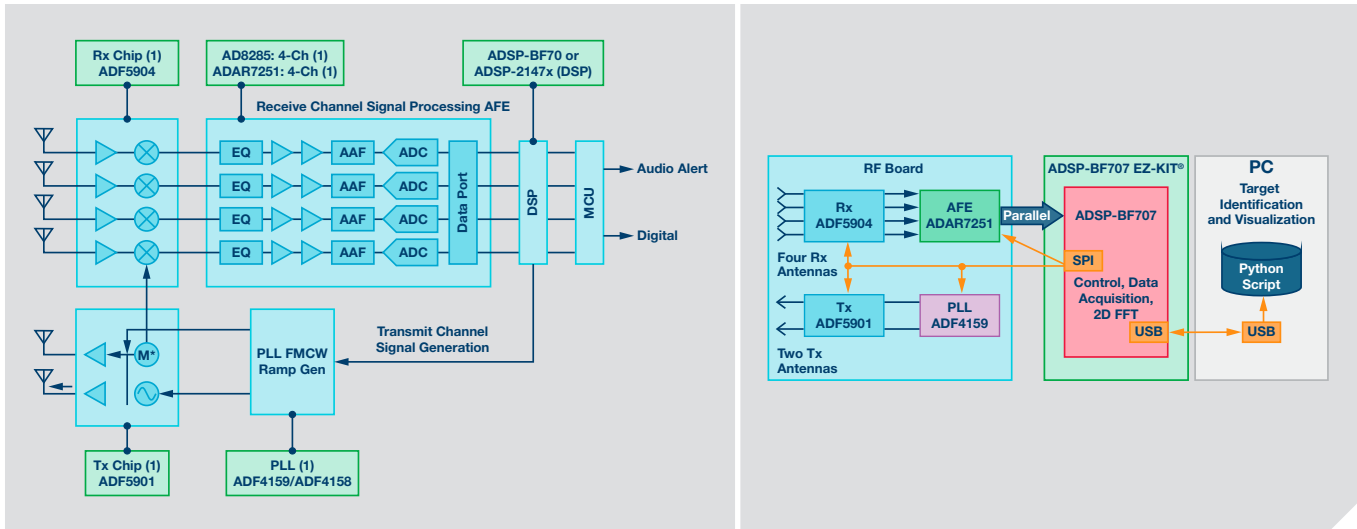

Part Number	Description	Function
ADF4159	13 GHz fractional-N FMCW ramping PLL	Ramp generator
ADF5901	ISM band, 2-channel FMCW transmitter	Transmitter MMIC
ADF5904	ISM band 4-channel receiver	Receiver MMIC
ADAR7251	4-channel, 16-bit continuous time data acquisition ADC	AFE
ADSP-BF70x	Low power ADSP-BF70x series of Blackfin+® embedded DSP processors with 512 kB L2 SRAM and DDR2/LPDDR interface	DSP

Demorad Details

The Demorad uses ADI's 24 GHz, multichannel radar solution. The sensor consists of a single PCB with 2 transmitter/4 receiver antennas on the front side connected to the 24 GHz RF chipset and data acquisition ADCs and DSPs on the reverse side. This forms the basis for a reference design that customers can use to build their final product design.

The Demorad uses FMCW radar to detect range and velocity of objects up to 200 m away with a resolution of approximately 75 cm. The field of view (FOV) is approximately 120° in azimuth and 15° in elevation based on the antenna array design. By combining antennas as used in digital beamforming (DBF), the Demorad uses DBF to calculate angular information in the FOV.

Applications

- ▶ Traffic monitoring and car parking
- ▶ UAV/drone collision avoidance and altimeters
- ▶ Monitoring and security systems

Website Links

analog.com

Radar application EngineerZone® link:
ez.analog.com/community/partnerzone/inras-eu

24 GHz product links:
analog.com/adf5904
analog.com/adf5901

Analog Devices, Inc.
Worldwide Headquarters

Analog Devices, Inc.
One Technology Way
P.O. Box 9106
Norwood, MA 02062-9106
U.S.A.
Tel: 781.329.4700
(800.262.5643, U.S.A. only)
Fax: 781.461.3113

Analog Devices, Inc.
Europe Headquarters

Analog Devices GmbH
Otto-Aicher-Str. 60-64
80807 München
Germany
Tel: 49.89.76903.0
Fax: 49.89.76903.157

Analog Devices, Inc.
Japan Headquarters

Analog Devices, KK
New Pier Takeshiba
South Tower Building
1-16-1 Kaigan, Minato-ku,
Tokyo, 105-6891
Japan
Tel: 813.5402.8200
Fax: 813.5402.1064

Analog Devices, Inc.
Asia Pacific Headquarters

Analog Devices
5F, Sandhill Plaza
2290 Zuchongzhi Road
Zhangjiang Hi-Tech Park
Pudong New District
Shanghai, China 201203
Tel: 86.21.2320.8000
Fax: 86.21.2320.8222

©2017 Analog Devices, Inc. All rights reserved. Trademarks and registered trademarks are the property of their respective owners. Ahead of What's Possible is a trademark of Analog Devices. PH15869-3-4/17

analog.com

ANALOG DEVICES

AHEAD OF WHAT'S POSSIBLE™