

NEMA 5-15P
MOLDED PLUG
COLOR: BLACK

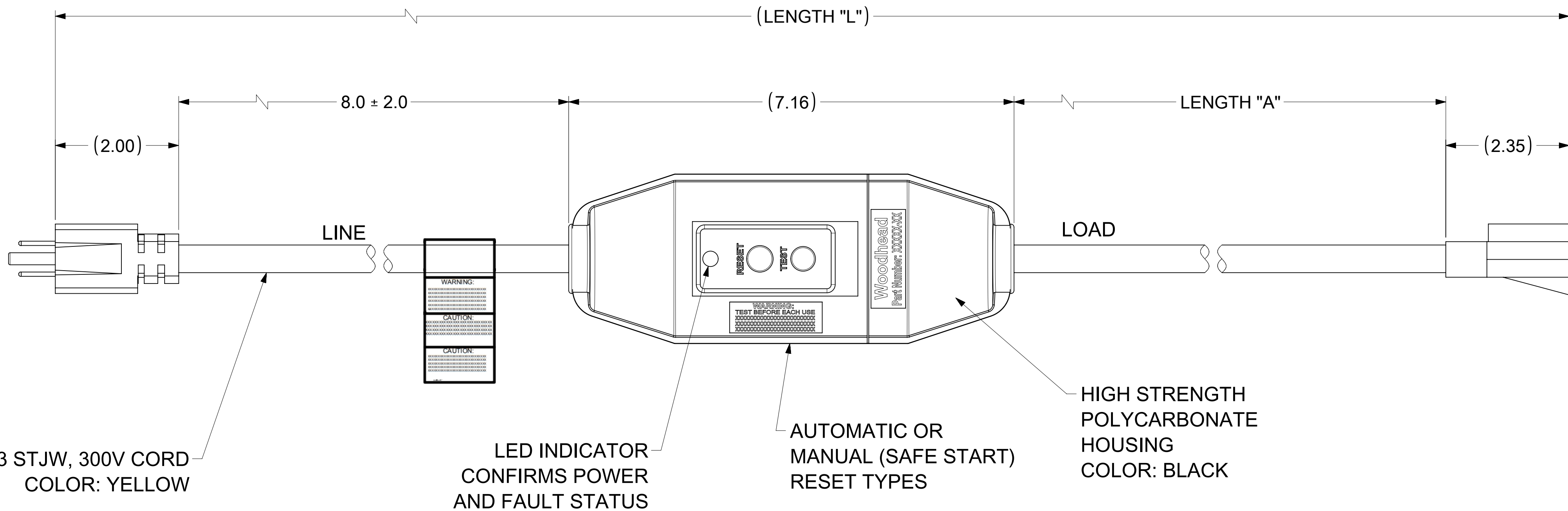

#12-3 STJW, 300V CORD
COLOR: YELLOW

LED INDICATOR
CONFIRMS POWER
AND FAULT STATUS

AUTOMATIC OR
MANUAL (SAFE START)
RESET TYPES

HIGH STRENGTH
POLYCARBONATE
HOUSING
COLOR: BLACK

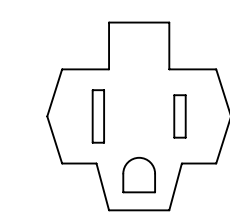

NEMA 5-15R
MOLDED CONNECTOR
COLOR: BLACK

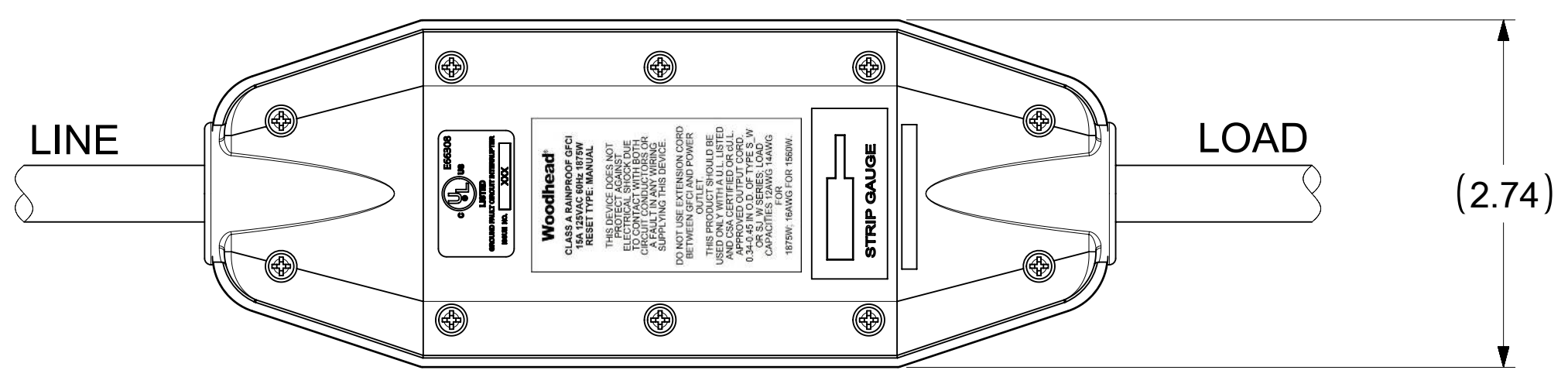
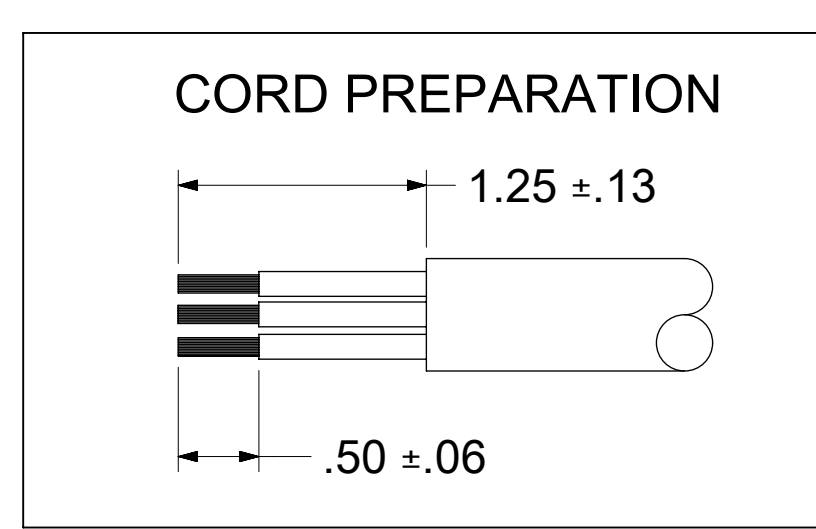
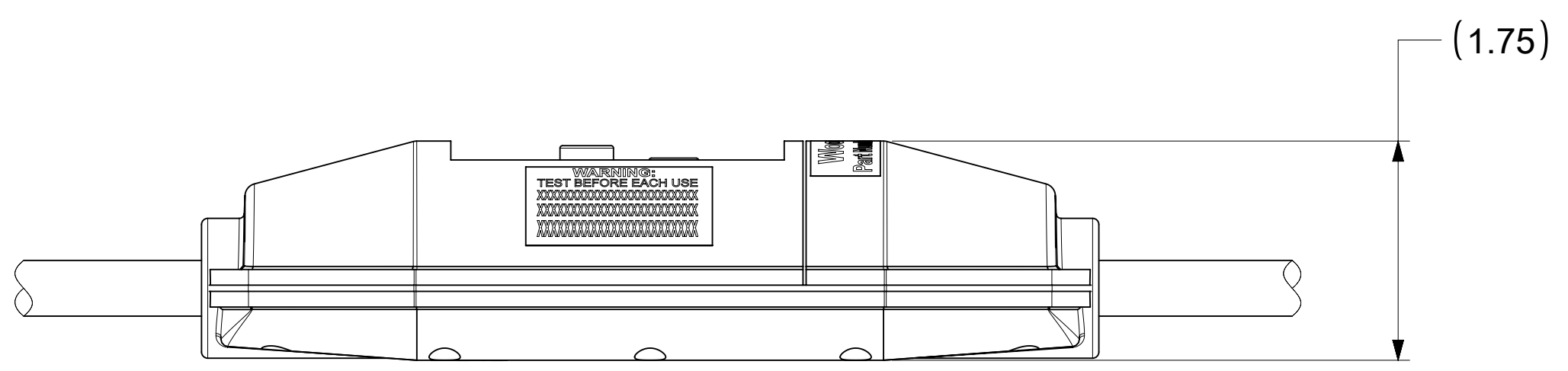

MATERIAL NO.	ENGINEERING NO.	LENGTH "L"	LENGTH "A"	POWER-UP
1301530020	15050-1A	2 FT 7.5 IN	1 FT ± 1 IN	AUTO
1301530037	15050-6A	7 FT 7.5 IN	6 FT ± 2 IN	AUTO
1301530023	15050-25A	26 FT 7.5 IN	25 FT ± 2 IN	AUTO
1301530031	15050-50A	51 FT 7.5 IN	50 FT ± 4 IN	AUTO
1301530021	15050-1M	2 FT 7.5 IN	1 FT ± 1 IN	MANUAL
1301530038	15050-6M	7 FT 7.5 IN	6 FT ± 2 IN	MANUAL
1301530024	15050-25M	26 FT 7.5 IN	25 FT ± 2 IN	MANUAL
1301530032	15050-50M	51 FT 7.5 IN	50 FT ± 4 IN	MANUAL

TECHNICAL:
LISTED: UL AND cUL
RATED SUPPLY VOLTAGE: 120 VAC
RATED CURRENT: UP TO 15 AMPS OR CABLE RATING
RESET TYPE: AUTOMATIC OR MANUAL
OPERATING FREQUENCY: 60 Hz
TYPE: CLASS A
GROUND TRIP CURRENT: 4-6 mA
OVERLOAD CURRENT: 90 AMP 125 VAC
INSULATION VOLTAGE: 1,500 VRMS - 1 MINUTE
ENDURANCE OPERATIONS: 3000 OPERATIONS

FUNCTIONAL SYMBOLS FA = 0 FC = 0 FD = 0 DIVISIONAL SYMBOLS	THIS DRAWING CONTAINS INFORMATION THAT IS PROPRIETARY TO MOLEX ELECTRONIC TECHNOLOGIES, LLC AND SHOULD NOT BE USED WITHOUT WRITTEN PERMISSION	SCALE INCH NTS	CURRENT REV DESC: EC NO: 686220 DRWN: VBASUTHKARP 2021/11/11 CHK'D: DNGUYEN62 2021/12/01 APPR: HKNEELAND 2022/01/04 INITIAL REVISION: DRWN: HRUIZ01 2013/02/06 APPR: JFMURPHY 2015/04/20					
	GENERAL TOLERANCES (UNLESS SPECIFIED) ANGULAR TOL ± 0.5° 4 PLACES ± 3 PLACES ± 2 PLACES ± 0.13 1 PLACE ± 0.25 0 PLACES ±	120V 15A INLINE GFCI W/ MOLDED PLUG & CONN NEMA 5-15 PRODUCT CUSTOMER DRAWING						
DRAFT WHERE APPLICABLE MUST REMAIN WITHIN DIMENSIONS		THIRD ANGLE PROJECTION	D-SIZE	SERIES 130153	MATERIAL NUMBER SEE TABLE	CUSTOMER NORTH SHORE SAFETY	SHEET NUMBER 1 OF 1	