

DUO mXTEND™: The tiny antenna for simultaneous GNSS and Bluetooth operation with no clearance beyond the antenna footprint

- **Antenna component:** DUO mXTEND™ NN03-320
- **Dimensions:** 7.0 mm x 3.0 mm x 2.0 mm
- **Frequency regions:** 1561 MHz, 1575 MHz, and 1598 MHz to 1606 MHz, and 2400 MHz to 2500 MHz

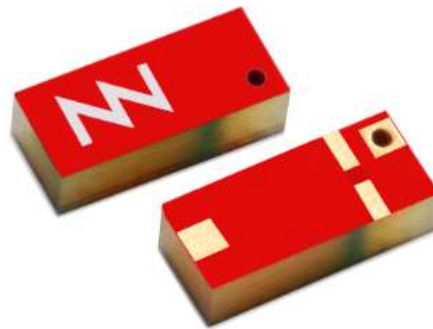

Small and with **no clearance** beyond the footprint, the ideal antenna features for your next IoT wireless device.

The new **miniature, modular, multipurpose** antenna booster by FRACTUS ANTENNAS, DUO mXTEND™ (NN03-320), delivers **GNSS** and **Bluetooth** connectivity worldwide **simultaneously**, thanks to its **multiport** nature.

The new DUO mXTEND™ tiny antenna booster can get an optimum performance, while **no ground clearance** beyond the antenna footprint is needed, making this component the ideal solution for small IoT wireless devices.

Doesn't matter the size or form factor of the wireless device, DUO mXTEND™ fits in about all of them because is tiny, only **7.0 x 3.0 x 2.0 mm** giving the designer more flexibility for allocating the other electronic components. Since the device does not need any clearance on the PCB ground beyond its antenna footprint, you can use the proximity area in the component to arrange other element in the PCB.

INDEX OF CHAPTERS

1. PRODUCT DESCRIPTION NN03-320.....	4
2. EVALUATION BOARD (GPS/GLONASS/BeiDou and Bluetooth)	5
3. CAPABILITIES AND MEASUREMENT SYSTEMS.....	10
4. MECHANICAL CHARACTERISTICS NN03-320.....	11
5. ASSEMBLY PROCESS.....	13
6. PACKAGING	15

TABLE OF CONTENTS

1. PRODUCT DESCRIPTION NN03-320.....	4
2. EVALUATION BOARD (GPS/GLONASS/BeiDou and Bluetooth)	5
2.1. QUICK REFERENCE GUIDE	5
2.2. EVALUATION BOARD.....	5
3. CAPABILITIES AND MEASUREMENT SYSTEMS.....	10
4. MECHANICAL CHARACTERISTICS NN03-320.....	11
4.1. DIMENSIONS, TOLERANCES, AND RoHS	11
4.2. COLOR RANGE FOR THE INK.....	11
4.3. RECOMMENDED FOOTPRINT FOR THE NN03-320	12
5. ASSEMBLY PROCESS.....	13
6. PACKAGING	15

1. PRODUCT DESCRIPTION NN03-320

The DUO mXTEND™ antenna booster has been specifically designed for providing worldwide Global Navigation Satellite Systems (GNSS) and Bluetooth (BT) performance in wireless devices with small space requirements. It is a miniature antenna capable of being adapted, with a high level of flexibility, to the antenna designer needs. The DUO mXTEND™ antenna booster does not require further clearance area beyond its reduced footprint, making it an ideal alternative to larger custom antennas for small and portable tracking devices.

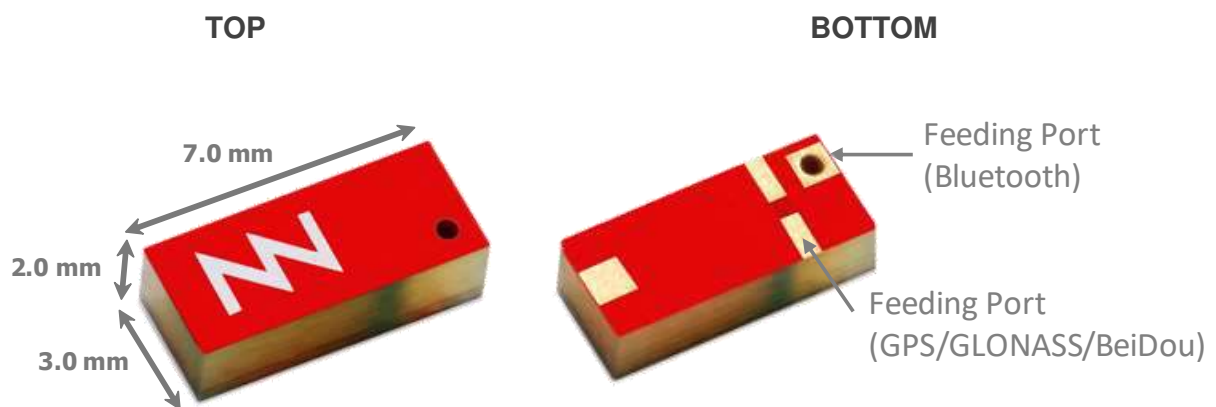

Material: The DUO mXTEND™ antenna booster is built on glass epoxy substrate.

APPLICATIONS

- Modules
- Smart tracking devices
- Sport navigators
- Handsets and smartphones
- Tablets
- Digital cameras
- Smartwatches and wearables

BENEFITS

- High efficiency
- Small size
- Cost-effective
- Easy-to-use (pick and place)
- Off-the-Shelf standard product (no customization is required)
- No clearance beyond footprint.

The DUO mXTEND™ antenna booster belongs to a new generation of antenna solutions based on Virtual Antenna™ technology owned by FRACTUS ANTENNAS. This technology enables replacing conventional and custom antenna solutions by a new class of so-called antenna boosters, delivered in the form of a new range of miniature and off-the-shelf chip antenna components. These new chip antennas are by nature multiband and multipurpose, so they fit in a variety of wireless platforms to provide a wireless link at many different communication services. By using a Virtual Antenna™ component the design becomes more predictable compared to a custom solution, making the whole process **faster, cheaper and easier**.

2. EVALUATION BOARD (GPS & GALILEO/GLONASS/BeiDou and Bluetooth)

2.1. QUICK REFERENCE GUIDE

Technical features	BeiDou	GPS & GALILEO	GLONASS	Bluetooth
	1561MHz	1575MHz	1598 – 1606MHz	2400 – 2500MHz
Average Efficiency	> 40%	> 45%	> 50%	> 50%
Peak Gain	-1.1 dBi	-1.0 dBi	-1.0 dBi	-0.9 dBi
VSWR	< 3:1			
Radiation Pattern	Omnidirectional			
Polarization	Linear			
Weight (approx.)	0.11 g.			
Temperature	-40 to +125 °C			
Impedance	50 Ω			
Dimensions (L x W x H)	7.0 mm x 3.0 mm x 2.0 mm			

Table 1 – Technical Features. Measures from the Evaluation Board. See Figure 1.

2.2. EVALUATION BOARD

This Evaluation Board (part number: EB_NN03-320-m-GNSS-BT) integrates one DUO mXTEND™ antenna booster to provide operation in four frequency regions, 1561MHz (BeiDou E1 band), 1575 MHz (GPS L1 band and GALILEO E1), from 1598 MHz to 1606 MHz (GLONASS L1 band) and from 2400 MHz to 2500MHz (Bluetooth). A couple of UFL cables connect this dual input/output port solution to the SMA connectors for testing purposes.

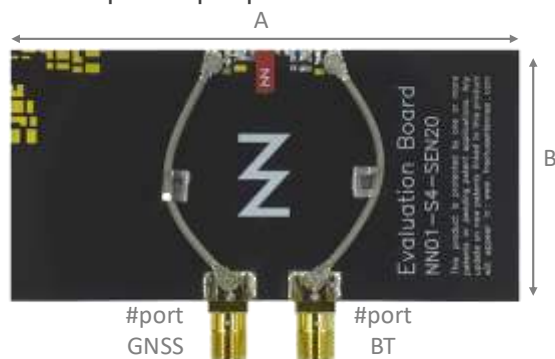

Measure	mm
A	80
B	40

Tolerance: ±0.2 mm

Material: The Evaluation Boards are built on FR4 substrate. Thickness is 1 mm.

Figure 1 – EB_NN03-320-m-GNSS-BT Evaluation Board providing operation at BeiDou E1 band (1561 MHz), GPS L1 band and GALILEO E1 band (1575 MHz), GLONASS L1 band (from 1598 MHz to 1606 MHz) and Bluetooth (from 2400MHz to 2480MHz). Notice that the clearance area is equal to the DUO mXTEND™ footprint.

This product and its use are protected by at least one or more of the following [patents and patent applications](#) PAT. US 62/529032; and other domestic and international patents pending. Additional information about patents related to this product is available at www.fractusantennas.com/virtual-antenna/.

2.2.1. MATCHING NETWORK

DUO mXTEND™ needs two matching networks to connect to your device, a first for the Bluetooth port, a second for the GNSS one (Figure 2). This section describes in (Figure 3) a suitable matching network for DUO mXTEND™ and the resulting product specs when measured in the reference evaluation board (EB_NN03-320-m-GNSS-BT) described in the previous section. Please note that different tracking devices with different form factors, RF ground planes and nearby components may need a different matching network. If you need assistance to design your matching network beyond this application note, please contact support@fractusantennas.com, or try our free-of-charge **NN Wireless Fast-Track** design service, you will get your chip antenna design including a custom matching network for your device in 24h¹. Other related to NN's range of R&D services is available at: <https://www.fractusantennas.com/rdservices/>

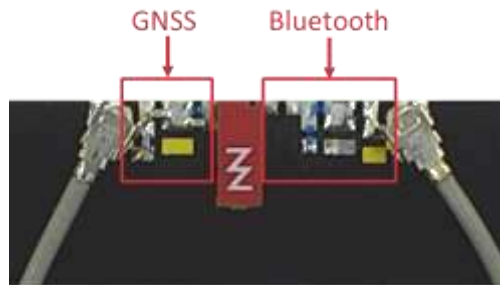

Figure 2 – Matching network distribution in the Evaluation Board (Figure 1).

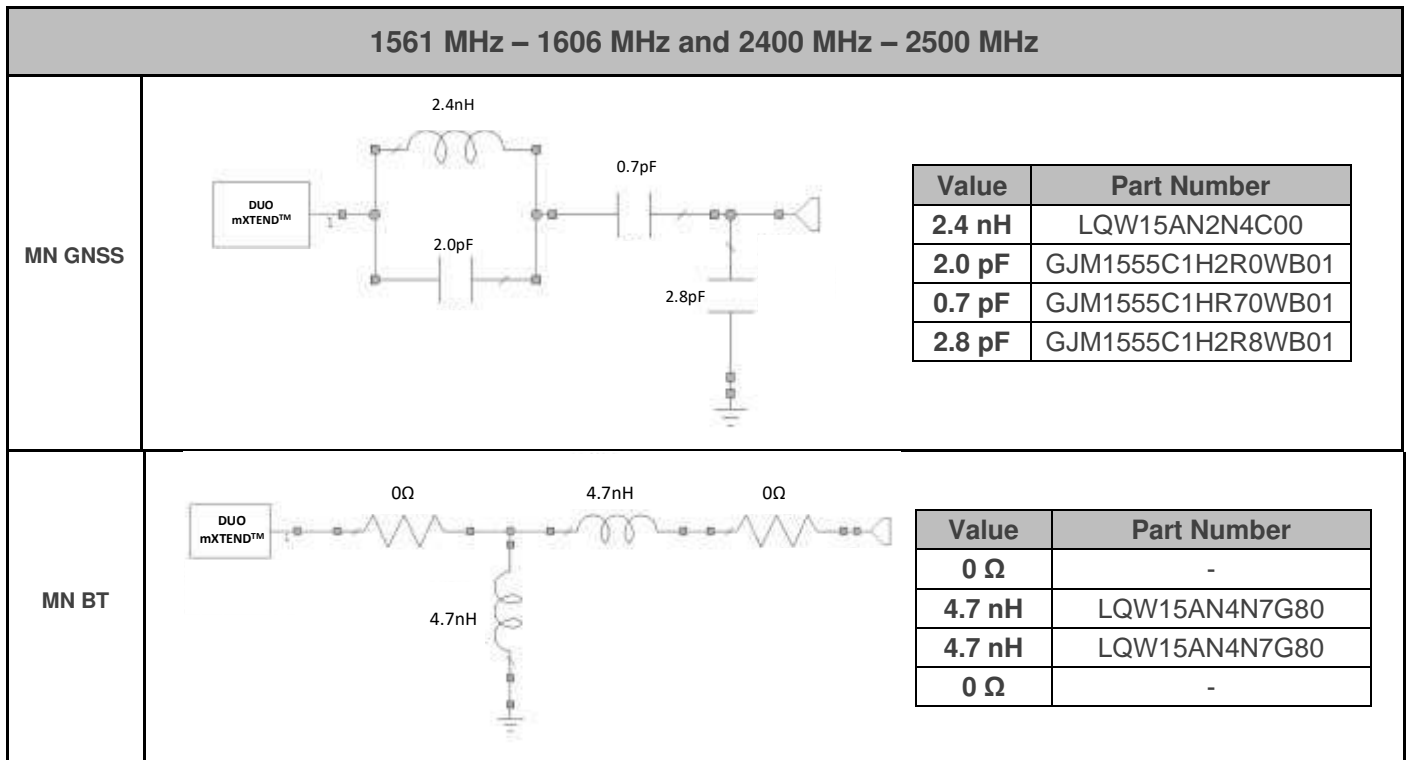

Figure 3 – Matching network implemented in the Evaluation Board 1 port (Figure 1).

¹ See terms and conditions for a free NN Wireless Fast-Track service at: <https://www.fractusantennas.com/fast-track-project/>

To ensure optimal results, the use of high-quality factor (Q) and tight tolerance components is highly recommended (e.g. Murata components with part numbers as in Figure 3). The antenna performance is always conditioned by its operating environment so that different devices with different printed circuit board sizes, components nearby the antenna, LCD's, batteries, covers, connectors, etc. affect the antenna performance. Accordingly, it is highly recommended placing pads compatible with 0402 and 0603 SMD components for a matching network as close as possible to the feeding point of the antenna element. Do it in the ground plane area, not in the clearance area. By tuning the matching network in your final design with your final surrounding components (batteries, displays, covers, etc.) you will be able to optimize the antenna performance without changing the antenna part.

2.2.2. VSWR AND TOTAL EFFICIENCY

VSWR (Voltage Standing Wave Ratio) and Total Efficiency versus Frequency (GHz).

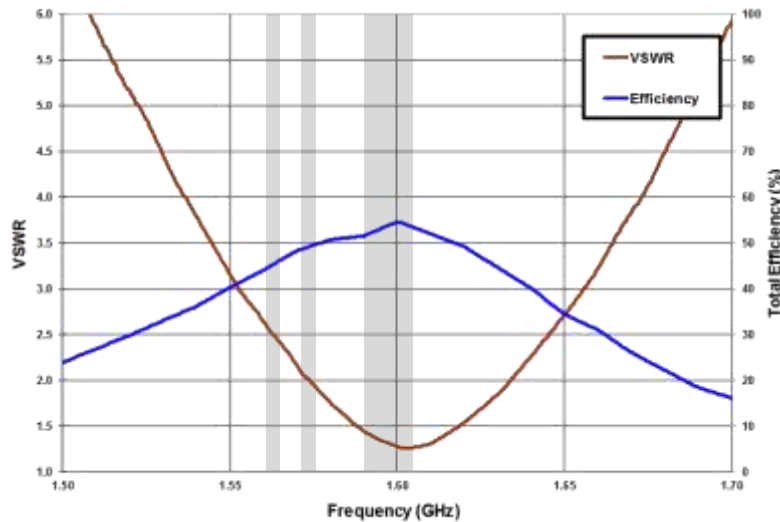

Figure 4 – VSWR and Total Efficiency at BeiDou E1 band (1561 MHz), GPS L1 band and GALILEO E1 band (1575 MHz), GLONASS L1 band (from 1598 to 1606 MHz) (from the Evaluation Board) (Figure 1).

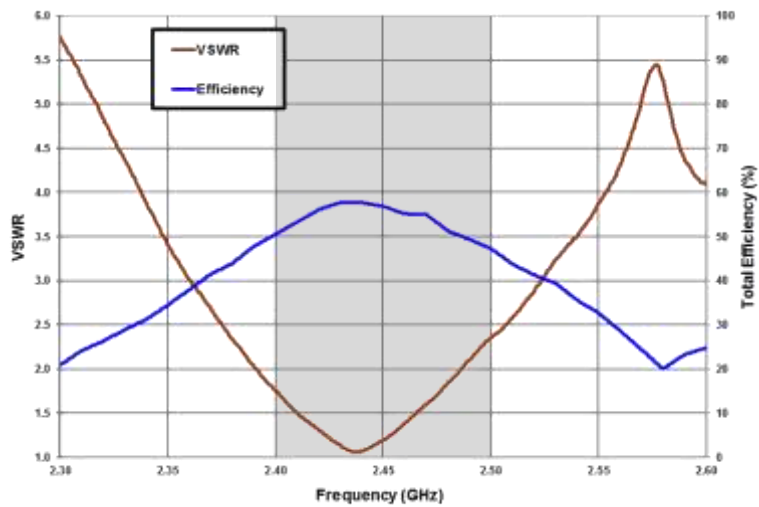
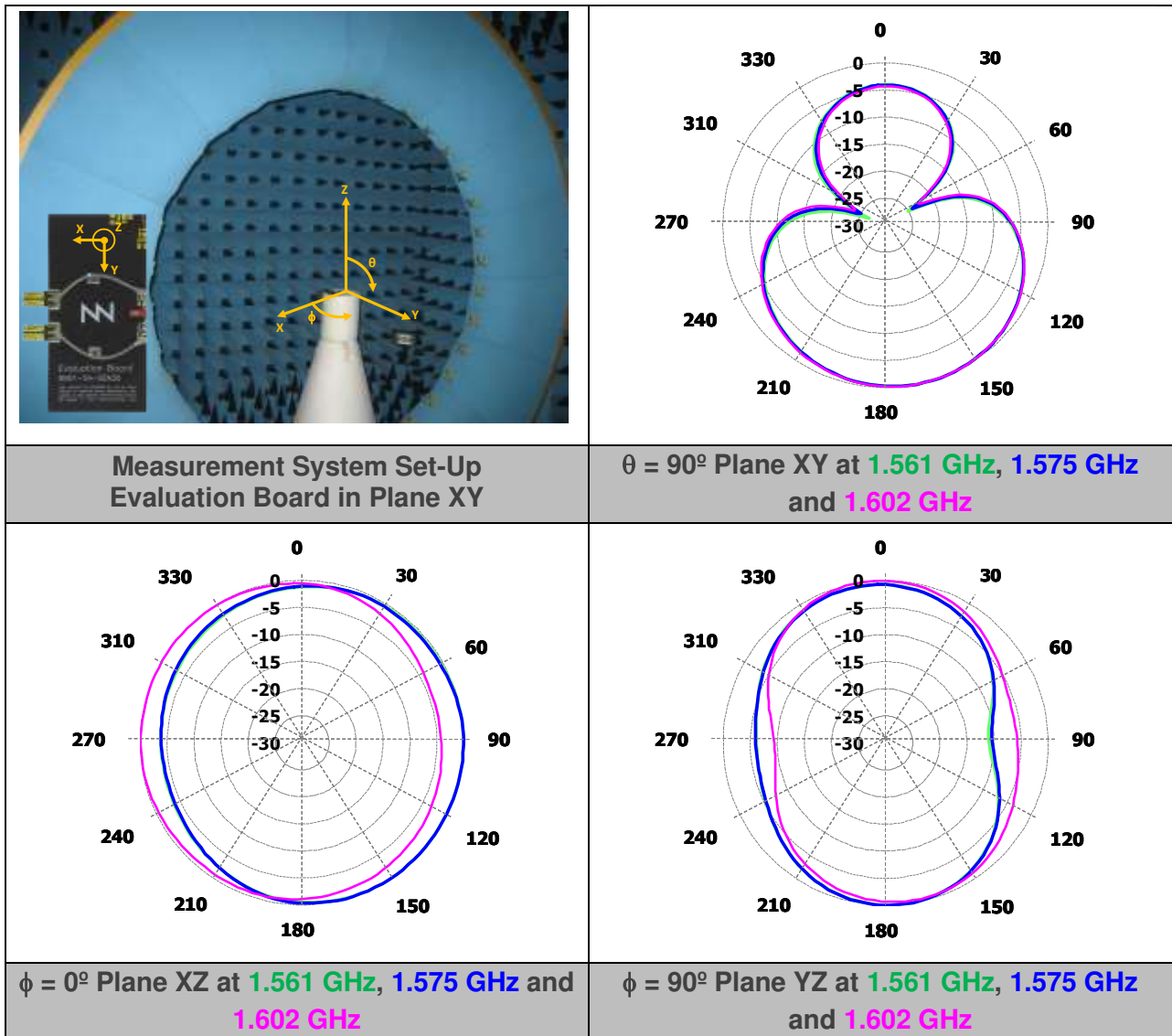

Figure 5 – VSWR and Total Efficiency for the 2400 – 2500 MHz (from the Evaluation Board) (Figure 1).

2.2.3. RADIATION PATTERNS (1561MHz, 1575MHz, and 1598 - 1606MHz), GAIN AND EFFICIENCY



BeiDou	Gain	-1.1 dBi	
	Efficiency	44.6 %	
GPS	Gain	-1.0 dBi	
	Efficiency	49.7 %	
GLONASS	Gain	Peak Gain	-1.0 dBi
		Average Gain across the band	-1.0 dBi
		Gain Range across the band (min, max)	-1.0 <-> -1.0 dBi
	Efficiency	Peak Efficiency	54.6 %
		Average Efficiency across the band	53.9 %
		Efficiency Range across the band (min, max)	53.0 – 54.6 %

Table 2 – Antenna Gain and Total Efficiency from the Evaluation Board (Figure 1) for BeiDou E1 (1561 MHz), GPS L1 (1575 MHz) and GLONASS L1 (1598 MHz – 1606 MHz) bands. Measures made in the Satimo STARGATE 32 anechoic chamber.

2.2.4. RADIATION PATTERNS (2400 - 2500 MHz) GAIN, AND EFFICIENCY

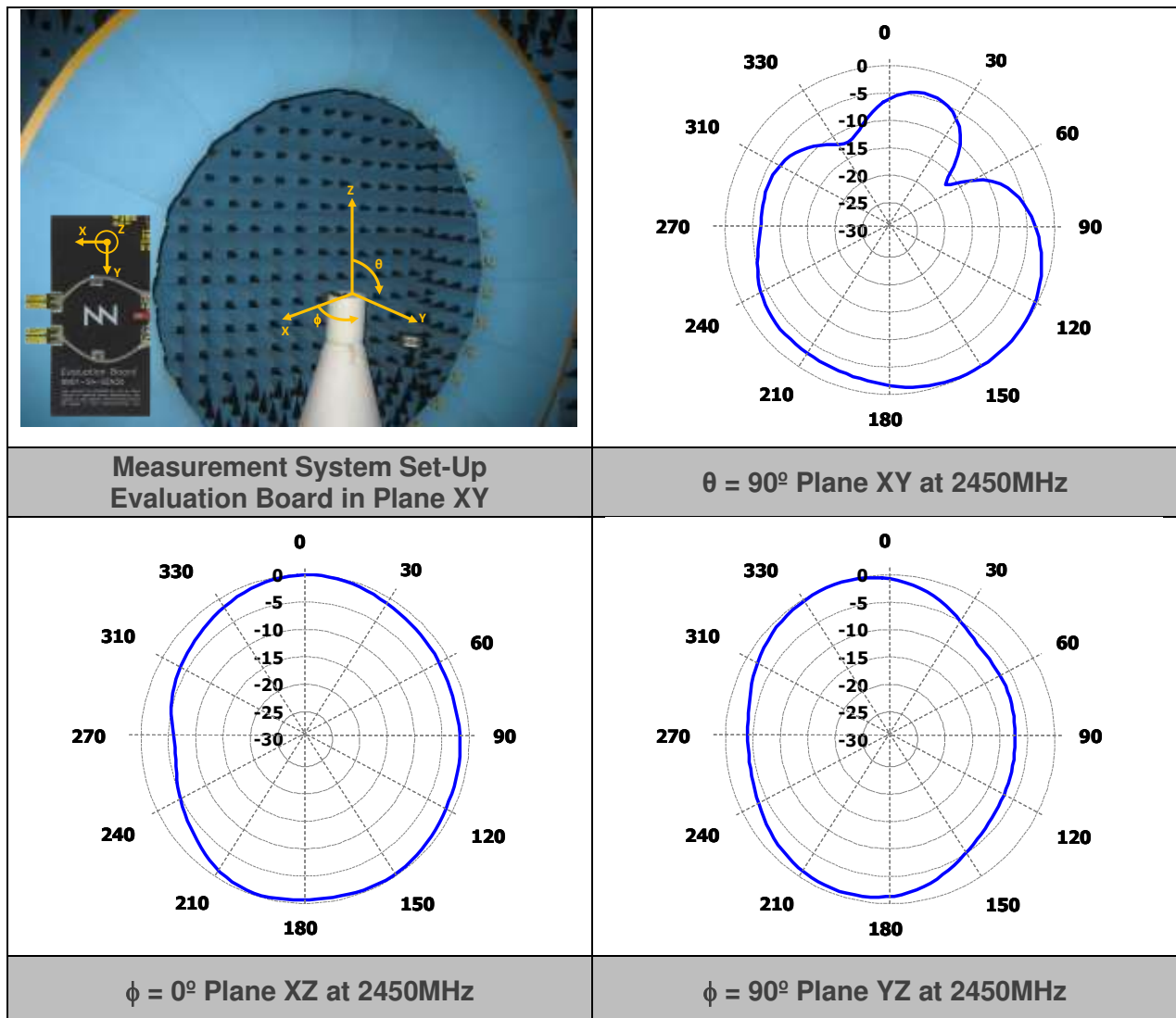

Gain	Peak Gain	-0.9 dBi
	Average Gain across the band	-0.9 dBi
	Gain Range across the band (min, max)	-1.0 dBi <-> -0.9 dBi
Efficiency	Peak Efficiency	57.7 %
	Average Efficiency across the band	54.1 %
	Efficiency Range across the band (min, max)	47.2 – 57.7 %

Table 3 – Antenna Gain and Total Efficiency for the Evaluation Board (Figure 1) for Bluetooth (2400 MHz - 2500 MHz). Measures made in the Satimo STARGATE 32 anechoic chamber.

3. CAPABILITIES AND MEASUREMENT SYSTEMS

Fractus Antennas specializes in designing and manufacturing optimized antennas for wireless applications and providing our clients with RF expertise. We offer turn-key antenna products and antenna integration support to minimize your time requirement and maximize your return on investment during your product development efforts. We also provide our clients with the opportunity to leverage our in-house testing and measurement facilities to obtain accurate results quickly and efficiently.



4. MECHANICAL CHARACTERISTICS NN03-320

4.1. DIMENSIONS, TOLERANCES, AND RoHS

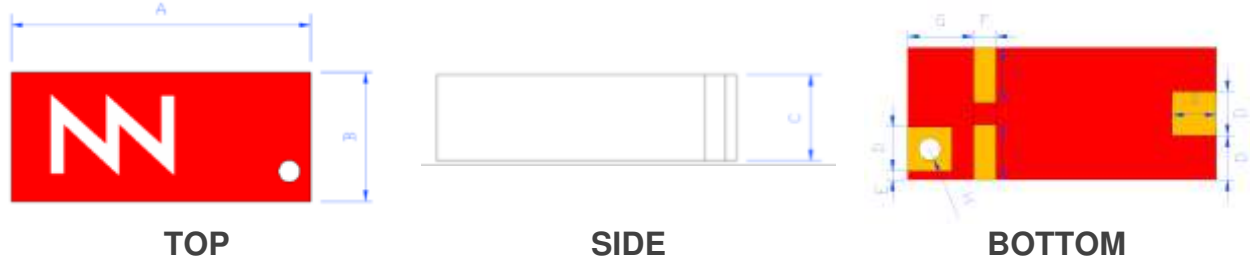

Dimension	mm	Dimension	mm
A	7.0 ± 0.2	B	3.0 ± 0.2
C	2.0 ± 0.1	D	1.0 ± 0.15
E	0.2 ± 0.1	F	0.5 ± 0.1
G	1.5 ± 0.1	H	R0.25 ± 0.1
I	1.25 ± 0.1		

Figure 6 – DUO mXTEND™ antenna booster dimensions and tolerances.

The DUO mXTEND™ antenna booster NN03-320 is compliant with the restriction of the use of hazardous substances (RoHS). For more information, please contact info@fractusantennas.com.

4.2. COLOR RANGE FOR THE INK

Next figure shows the range of the colors in the DUO mXTEND™ antenna booster:

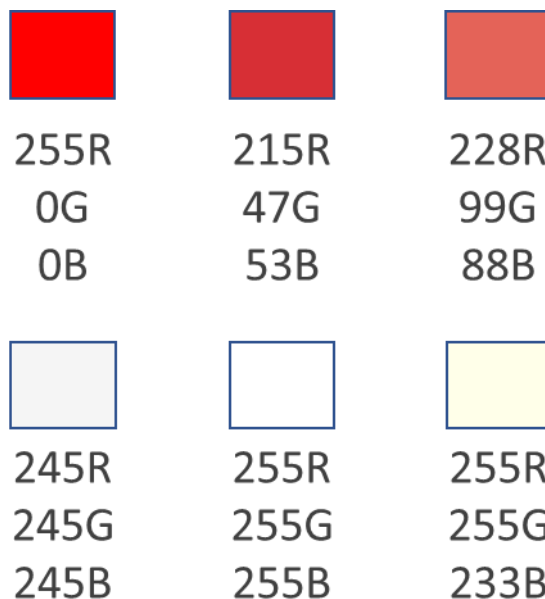

4.3. RECOMMENDED FOOTPRINT FOR THE NN03-320

See below the recommended footprint dimensions for the DUO mXTEND™ antenna booster NN03-320.

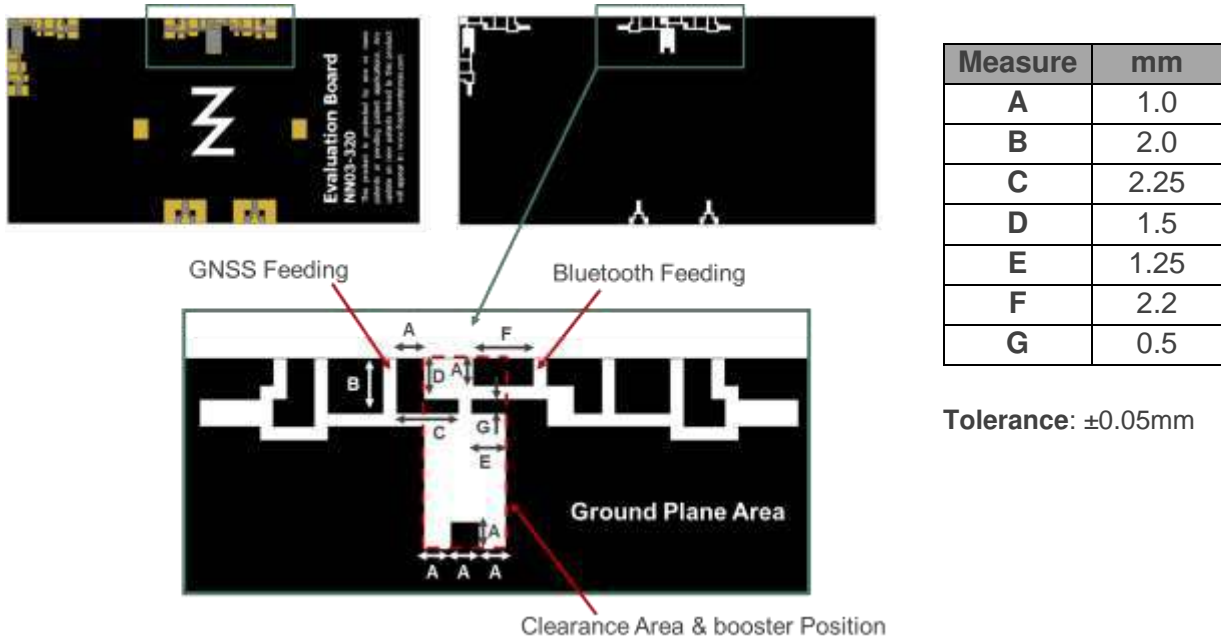

Figure 7 – Footprint dimensions for the the DUO mXTEND™ (NN03-320) antenna booster.

For additional support in the integration process, please contact support@fractusantennas.com.

5. ASSEMBLY PROCESS

Figure 8 shows the back and front views of the DUO mXTEND™ antenna booster (NN03-320).

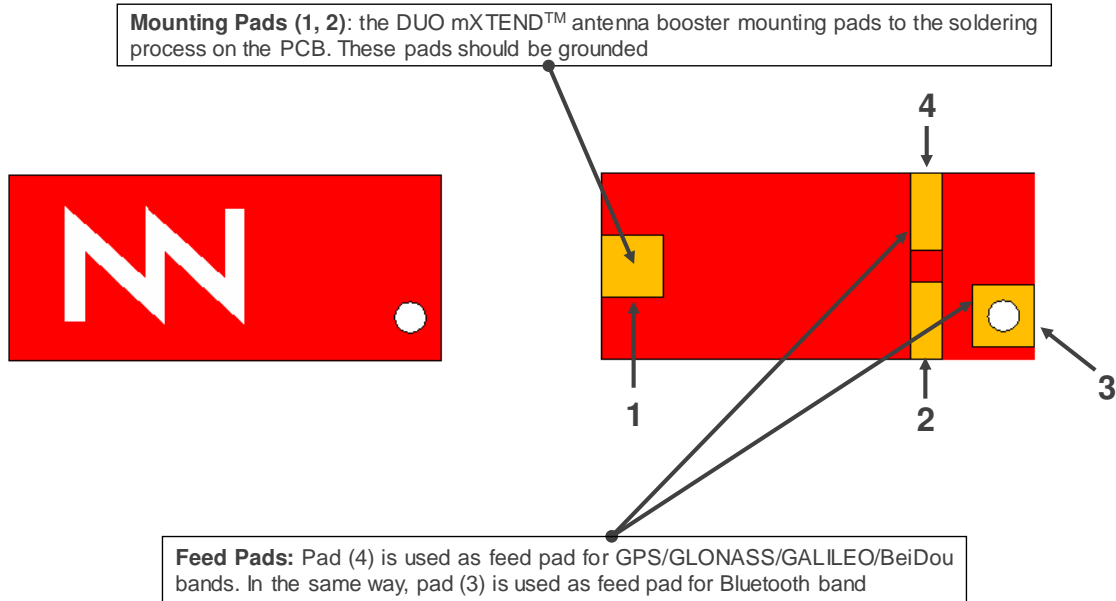

Figure 8 – Pads of the DUO mXTEND™ antenna booster NN03-320.

As a surface mount device (SMD), the DUO mXTEND™ antenna booster is compatible with industry standard soldering processes. The basic assembly procedure for the DUO mXTEND™ antenna booster is as follows:

1. Apply a solder paste on the pads of the PCB. Place the DUO mXTEND™ antenna booster on the board.
2. Perform a reflow process according to the temperature profile detailed in Table 4, Figure 10.
3. After soldering the DUO mXTEND™ antenna booster to the circuit board, perform a cleaning process to remove any residual flux. Fractus Antennas recommends conducting a visual inspection after the cleaning process to verify that all reflux has been removed.

The drawing below shows the soldering details obtained after a correct assembly process:

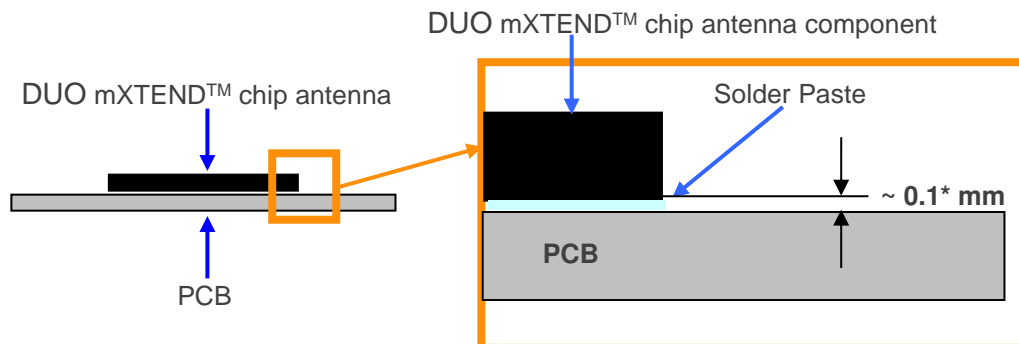

Figure 9 – Soldering Details.

NOTE(*): Solder paste thickness after the assembly process will depend on the thickness of the soldering stencil mask. A stencil thickness equal or larger than **127 microns (5 mils)** is required.

The DUO mXTEND™ antenna booster (NN03-320) can be assembled following the Pb-free assembly process. According to the Standard **IPC/JEDEC J-STD-020C**, the temperature profile suggested is as follows:

Phase	Profile features	Pb-Free Assembly (SnAgCu)
RAMP-UP	Avg. Ramp-up Rate (T _{smax} to T _p)	3 °C / second (max.)
PREHEAT	- Temperature Min (T _{smin}) - Temperature Max (T _{smax}) - Time (t _{smin} to t _{smax})	150 °C 200 °C 60-180 seconds
REFLOW	- Temperature (T _L) - Total Time above T _L (t _L)	217 °C 60-150 seconds
PEAK	- Temperature (T _p) - Time (t _p)	260 °C 20-40 seconds
RAMP-DOWN	Rate	6 °C/second max
Time from 25 °C to Peak Temperature		8 minutes max

Table 4 – Recommended soldering temperatures.

Next graphic shows temperature profile (grey zone) for the DUO mXTEND™ antenna booster assembly process reflow ovens.

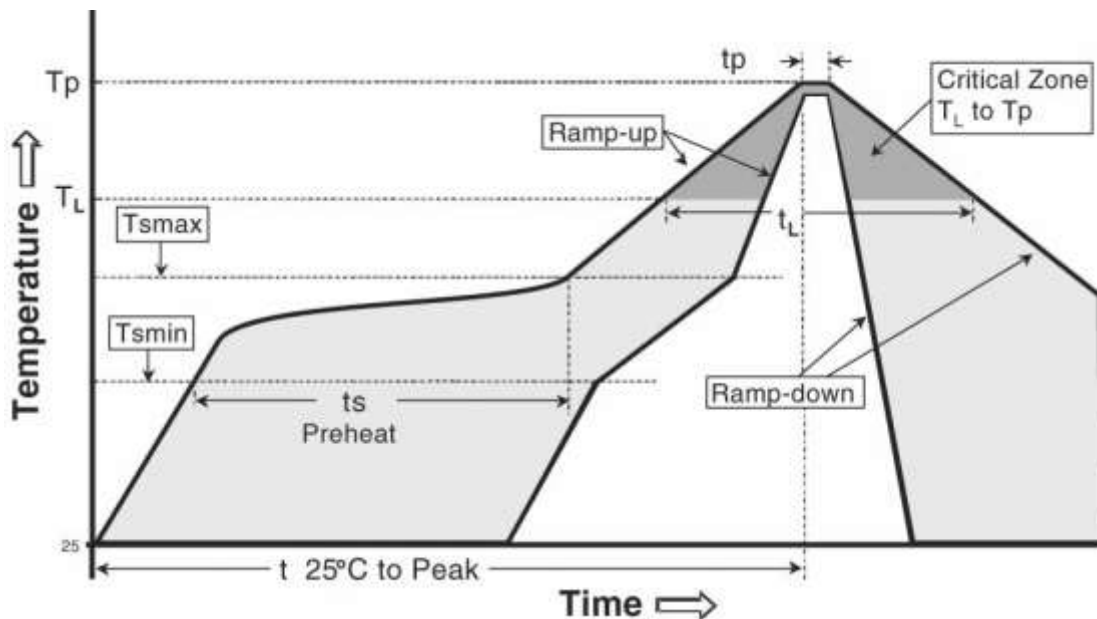
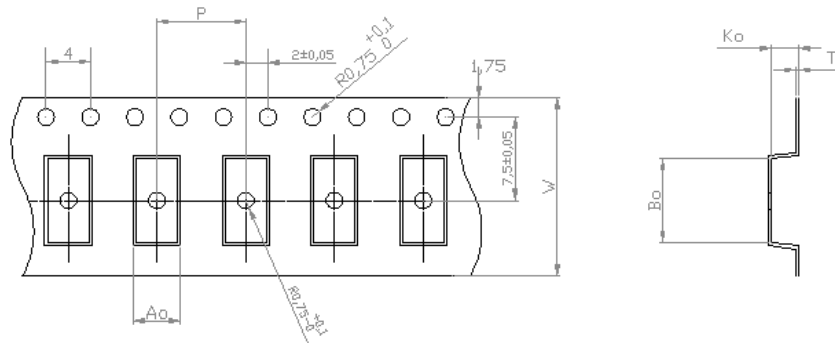

Figure 10 – Temperature profile.

6. PACKAGING

The DUO mXTEND™ antenna booster NN03-320 is delivered in tape and reel packaging.



Measure	mm
A0	3.6 ± 0.1
B0	7.5 ± 0.1
K0	2.5 ± 0.1
W	16.0 ± 0.3
P	8.0 ± 0.1
T	0.3 ± 0.05

Figure 11 – Tape dimensions and tolerances.

REEL DIMENSIONS

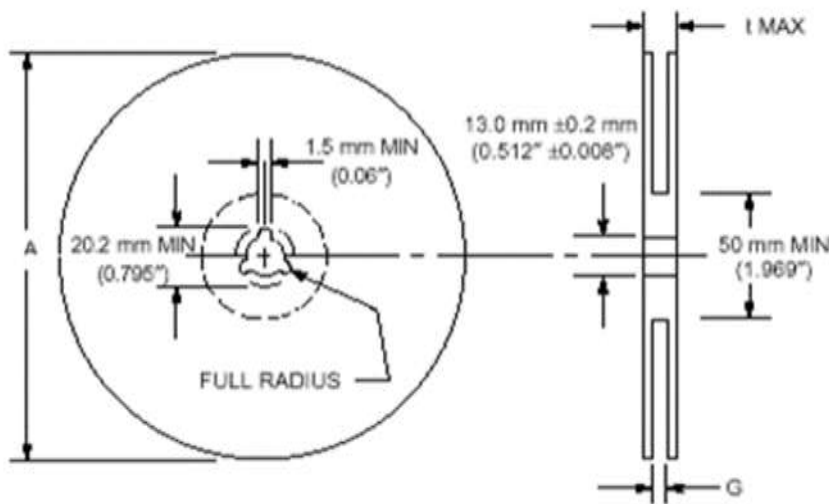

Measure	mm
A	330 ± 1.0
G	16.4 ± 0.1
t max	20.4 ± 0.1

Reel Capacity: 2500 pcs

Figure 12 – Reel dimensions and capacity.

FRACTUS ANTENNAS products and solutions are protected by [Fractus Antennas patents](#).

All information contained within this document is property of FRACTUS ANTENNAS and is subject to change without prior notice. Information is provided “as is” and without warranties. It is prohibited to copy or reproduce this information without prior approval.

FRACTUS ANTENNAS is an ISO 9001:2015 certified company. All our antennas are lead-free and RoHS compliant.

ISO 9001: 2015 Certified



This project has received funding from CDTI
under grant agreement IDI-20190285

