

4

3

2

1

NOTES:

1. MATERIAL:

- A) BACKSHELL COPPER ALLOY 172 PER QQ-A-533.
- B) BACKSHELL SCREW STAINLESS STEEL PER QQ-S-763, 300 SERIES
- C) CLAMP BAR STAINLESS STEEL PER QQ-S-766, 300 SERIES
- D) TRANSITION ALUMINUM ALLOY PER QQ-A-356.
- E) CLAMP SCREW STAINLESS STEEL PER QQ-S-766, 300 SERIES
- F) BRAID COPPER ALLOY
- G) TINEL™ LOCK RING ALLOY X
- H) BRAID END COVER SILICONE ELASTOMER

2. FINISH:

- A) BACKSHELL CADMIUM PLATED PER QQ-P-416
- B) BACKSHELL SCREW CADMIUM PLATED PER QQ-P-416
- C) CLAMP BAR CADMIUM PLATED PER QQ-P-416
- D) TRANSITION CADMIUM PLATED PER QQ-P-416
- E) CLAMP SCREW CADMIUM PLATED PER QQ-P-416
- F) BRAID TIN PLATED
- G) TINEL™ LOCK RING AS MANUFACTURED

3. RAYCHEM PART NUMBER CHA-0082-XXX AND DATE CODE ARE STAMPED APPROXIMATELY AS SHOWN. SEE TABULATION FOR PART NUMBERS.

4. THE 12.0 APPROX., LENGTH APPLIES TO THE BRAID IN ITS "FLAT" AS SUPPLIED CONDITION.

REVISIONS			
LTR	DESCRIPTION	DATE	APPROVED
A	RELEASED FOR PRODUCTION PER ECN T-012436	88NOV08	J.B.

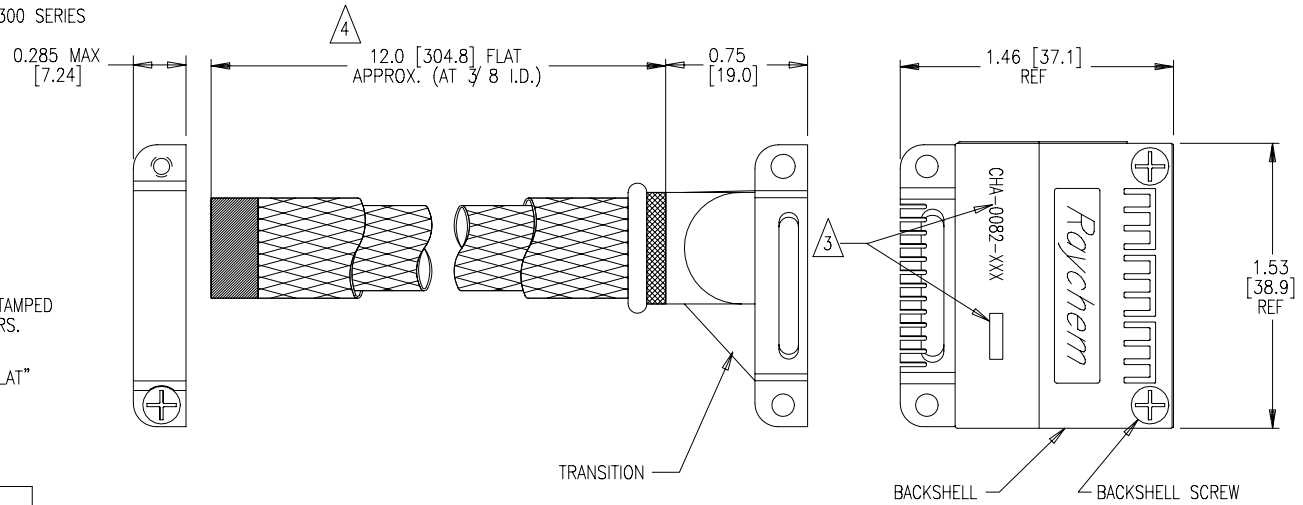

P/N <sup>3</sup>	DESCRIPTION	COMMENTS
CHA-0082	AS SHOWN	
CHA-0082-010	AS SHOWN EXCEPT SUPPLIED W/O BRAID & BRAID END COVER	DESIGNED TO ACCOMMODATE A DOUBLE LAYER OF 36 GA. BRAID P/N QQ-B-575 R 36T 0375 OR A SINGLE LAYER OF 30 GA. BRAID P/N QQ-B-575 R 30T 0375 RECOMMENDED BRAID TERMINATION PROCEDURE IS DESCRIBED IN RAYCHEM SPECIFICATION NO. MIP-101.
CHA-0082-011	AS SHOWN EXCEPT SUPPLIED W/O BRAID & BRAID END COVER	DESIGNED TO ACCOMMODATE A SINGLE LAYER OF 36 GA. BRAID P/N QQ-B-575 R 36T 0375 RECOMMENDED BRAID TERMINATION PROCEDURE IS DESCRIBED IN RAYCHEM SPECIFICATION NO. MIP-101.

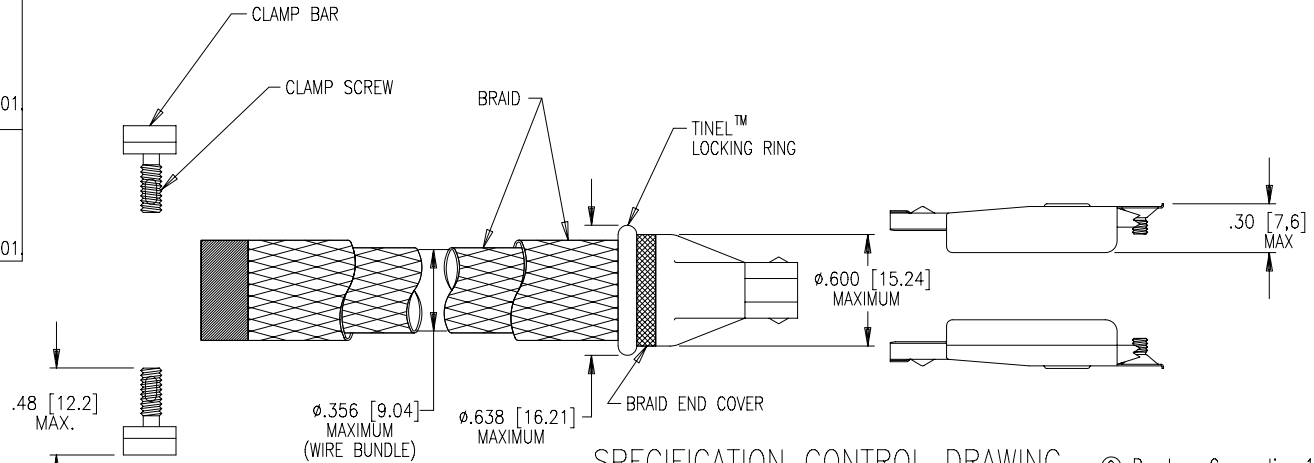
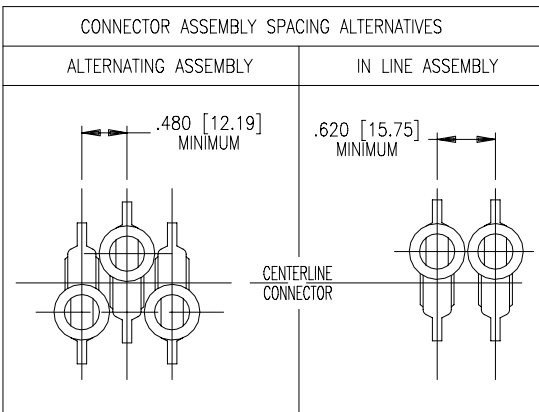

SPECIFICATION CONTROL DRAWING © Raychem Corporation 1988

UNLESS OTHERWISE SPECIFIED DIMENSIONS ARE IN INCHES. METRIC DIMENSIONS ARE IN BRACKETS.

DECIMALS  
 .XXX ± .005 [.13mm]  
 .XX ± .02 [.5mm]

ANGLES  
 .X ±

WEIGHT: MAXIMUM  
 .0923lbs. [1.866g.]

DRAWN	C.K.	12-4-85
CHECKED	J.B.	
APPROVED	J.BLAIR	7-25-86
APPROVED	J.CAMERON	7-25-86
CAD NAME	001061	
THIRD ANGLE PROJECTION		

		RAYCHEM CORPORATION 300 CONSTITUTION DRIVE MENLO PARK, CALIFORNIA 94025	
		TITLE BACKSHELL, RECEPTACLE, 1", ROUND WIRE 3/8" I.D., OFFSET, EME, CADMIUM PLATED	
MTC SERIES			
SIZE	CODE IDENT. NO.	DWG. NO.	REV
C	06090	CHA-0082-XXX	A
DO NOT SCALE THIS DRAWING			

If this document is printed it becomes uncontrolled. Check with the web for latest revision.

4

3

2

1

SHEET CHA-0082-XXX DWG. NO.

A

SHEET 1 OF 1