

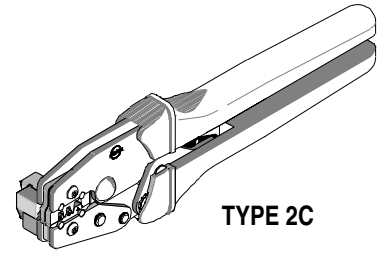

HAND CRIMP TOOL SPECIFICATION SHEET

Order No. 63811-5200



FEATURES

- A full cycle ratcheting hand tool ensures complete crimps
- Ergonomic soft grip handles for comfortable crimping
- A precision user-friendly terminal locator wire stop holds terminals in the proper crimping position
- This tool is WHMA-IPCA620 Class 2 and RoHS compliant

SCOPE

Products: 2.50mm (.098") Pitch SPOX™ Wire-to-Board and Wire-to-Wire Crimp Terminal, 22-28 AWG.

Terminal Series No.	Terminal Order No.			Wire Size		Ⓟ Insulation Diameter		Strip Length	
	Loose Piece	Ⓡ Reel		AWG	mm ²	mm	In.	mm	In.
5103	08-70-0057	08-70-0056	39-00-0188	22-28	0.35-0.08	1.15-1.90	.045-.075	3.30-3.80	.130-.150
	39-00-0189	08-70-0058	39-00-0387						
	39-00-0389	08-700-0569	39-00-0388						
	39-00-0390	08-700-0589							
5263	08-70-1039	08-70-1040	39-00-0159	22-28	0.35-0.08	1.15-1.90	.045-.075	3.30-3.80	.130-.150
	08-70-1045	08-70-1046							
	39-00-0151	39-00-0152							
45627		45627-0002		22-24	0.35-0.20	1.15-1.90	.045-.075	3.30-3.80	.130-.150
50802	50802-8100	50802-8000		22-24	0.35-0.20	1.15-1.90	.045-.075	3.30-3.80	.130-.150
	50802-9101	50802-9001							

Ⓡ Customer to cut off terminal from reel: 0.30mm (.012") maximum Cut-off Tab.
Ⓟ See Conditions on page 2.

DEFINITION OF TERMS

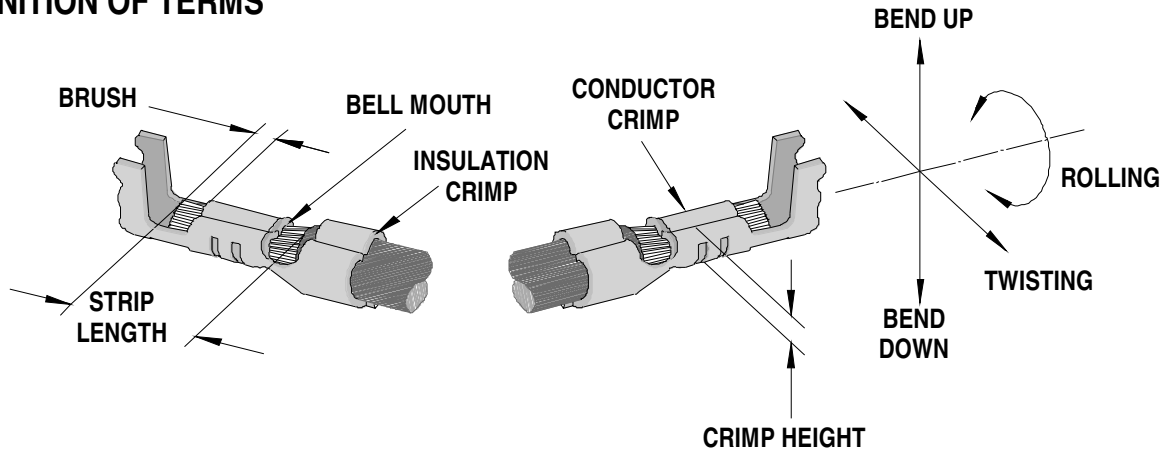

The above terminal drawing is a generic terminal representation. It is not an image of a terminal listed in the scope.

CONDITIONS:

After crimping, the conductor profiles should measure the following (see notes on page 5).

Terminal Series No.	Hand Tool Locator	Wire Size		Conductor Crimp				Insulation Crimp				Pull Force Minimum		* Profile		
				Height (Ref.)		Width (Ref.)		Height (Ref.)		Width (Ref.)						
		AWG	mm ²	mm	In.	mm	In.	mm	In.	mm	In.	N	Lb.	A	B	C
5103	1	22	0.35	0.73-0.80	.029-.031	1.40	.055	1.68	.066	1.90	.075	44.48	10.0	X		
	1	24	0.20	0.67-0.74	.026-.029	1.40	.055	1.57	.062	1.90	.075	28.91	6.5		X	
	1	26	0.12	0.63-0.69	.025-.027	1.40	.055	1.42	.056	1.50	.059	17.79	4.0			X
	1	28	0.08	0.61-0.67	.024-.026	1.40	.055	1.42	.056	1.50	.059	11.12	2.5			X
5263	1	22	0.35	0.73-0.80	.029-.031	1.40	.055	1.68	.066	1.90	.075	44.48	10.0	X		
	1	24	0.20	0.67-0.74	.026-.029	1.40	.055	1.57	.062	1.90	.075	28.91	6.5		X	
	1	26	0.12	0.63-0.69	.025-.027	1.40	.055	1.42	.056	1.50	.059	17.79	4.0			X
	1	28	0.08	0.61-0.67	.024-.026	1.40	.055	1.42	.056	1.50	.059	11.12	2.5			X
50802	1	22	0.35	0.73-0.80	.029-.031	1.40	.055	1.68	.066	1.90	.075	44.48	10.0	X		
	1	24	0.20	0.67-0.74	.026-.029	1.40	.055	1.57	.062	1.90	.075	28.91	6.5		X	
	1	26	0.12	0.63-0.69	.025-.027	1.40	.055	1.42	.056	1.50	.059	17.79	4.0			X
	1	28	0.08	0.61-0.67	.024-.026	1.40	.055	1.42	.056	1.50	.059	11.12	2.5			X
45627	2	22	0.35	0.73-0.80	.029-.031	1.40	.055	1.68	.066	1.90	.075	44.48	10.0	X		
	2	24	0.20	0.67-0.74	.026-.029	1.40	.055	1.57	.062	1.90	.075	28.91	6.5		X	

* To Achieve IPC-A-620 Class 2 crimps. The following over-all wire insulation diameter ranges are recommended:

1. Profile A: 1.20-1.90mm (.047-.075 inch)
2. Profile B: 1.20-1.55mm (.047-.061 inch)
3. Profile C: 1.15-1.30mm (.045-.051 inch)

OPERATION

CAUTION: Install only Molex terminals listed above with this tool. Do not crimp hardened objects as damage can occur to the tool or die.

Open the tool by squeezing the handles together, at the end of the closing stroke, the ratchet mechanism will release the handles, and the hand tool will spring open.

Crimping Terminals

1. Select the desired terminal listed in the preceding charts. Make sure that the proper locator is mounted on the tool.
2. Swing the terminal locator away from the crimp tool shown in Figure 2. Some terminals with large insulation grips may interfere with the crimp tooling when swinging the locator into position. The terminal must then be loaded into the locator in the closed/crimp position.
3. When using the locator, press down on the wire stop on the locator as shown in Figure 2. Insert the proper terminal into the proper nest opening. Make sure when choosing the nest opening, it will correspond with the A, B, or C profile on the hand tool.
4. Return the locator to its original position.
5. Insert the proper wire over the terminal. Some large O.D. wires may need to be placed into the terminal before closing the tool. Gently touch the wire stop with the end of the wire. See Figure 3.
6. Compress the terminal by squeezing the tool handles until the ratchet mechanism cycle has been completed. Release handles to open the jaws.

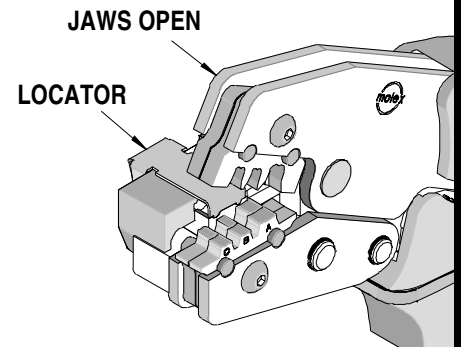
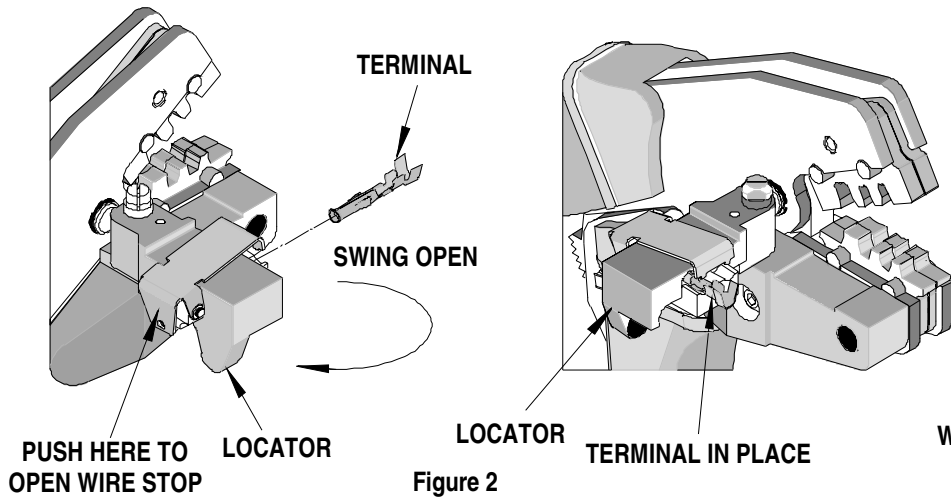

Figure 1

Note: The tamper proof ratchet action will not release the tool until it has been fully closed.



7. Remove the crimped terminal from the terminal locator by pressing down on the wire stop and gently pulling on the wire. The terminal locator can be in either position.
8. Visually inspect the crimped terminal for proper crimp location.

Note:

A crimp height chart is provided with this manual as Reference Only. Due to the wide range of wires, strands, insulation diameters, and durometers, actual crimp height measurements may vary slightly. An occasional, destructive, pull force test should be performed to check hand tool crimp. Pull Force value Must exceed the Minimum pull force specifications listed on page 2.

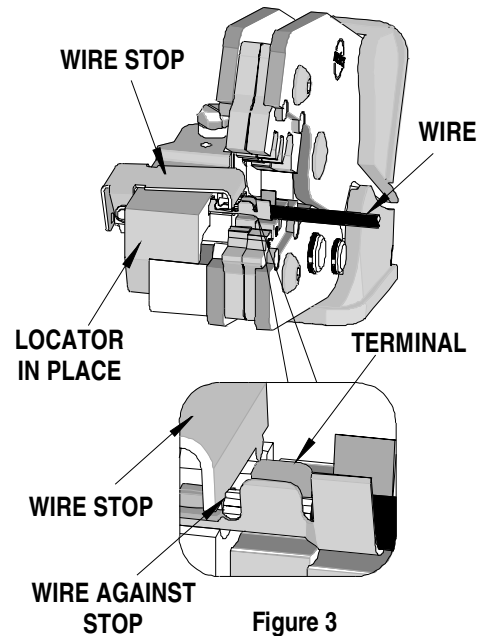

Locator Change Over and Replacement

Multiple styles of locators maybe provided with the crimp hand tool. They are different colors for easy identification. See the parts list on the last page of the document. Make sure the desired style of locator is installed for the proper terminal and wire. Follow the steps below to change the locators.

1. Open the crimp hand tool.
2. Swing the existing locator open and away from the hand tool.
3. Firmly press down on the brass pivot shaft with your thumb, while pulling the locator up. Slip the locator off the top of the brass pivot shaft. See Figure 4.
4. Replace it with the desired locator by putting over the brass pivot shaft and snapping it into place.

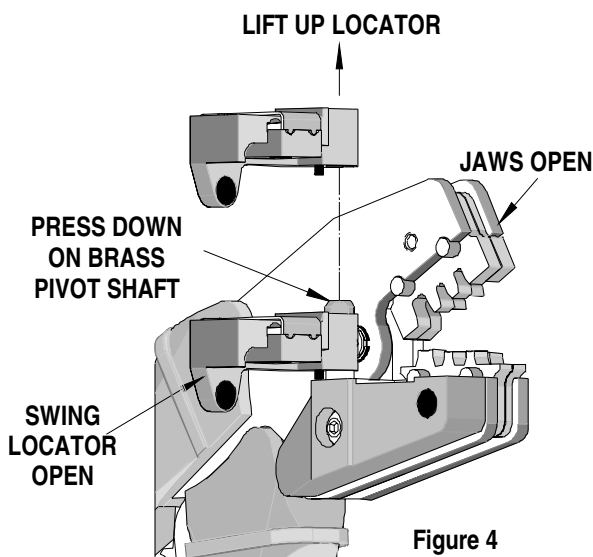

Maintenance

It is recommended that each operator of the tool be made aware of, and responsible for, the following maintenance steps:

1. Remove dust, moisture, and other contaminants with a clean brush, or soft, lint free cloth.
2. Do not use any abrasive materials that could damage the tool.
3. Make certain all pins; pivot points and bearing surfaces are protected with a thin coat of high quality machine oil. Do not oil excessively. This tool was engineered for durability but like any fine piece of equipment it needs cleaning and lubrication for a maximum service life of trouble free crimping. Light oil such as 30 weight automotive oil used at the oil points shown in Figure 6, every 5,000 crimps or 3 months, will significantly enhance the tool life.
4. Wipe excess oil from hand tool, particularly from crimping area. Oil transferred from the crimping area onto certain terminations may affect the electrical characteristics of an application.
5. When tool is not in use, keep the handles closed to prevent objects from becoming lodged in the crimping dies, and store the tool in a clean, dry area.

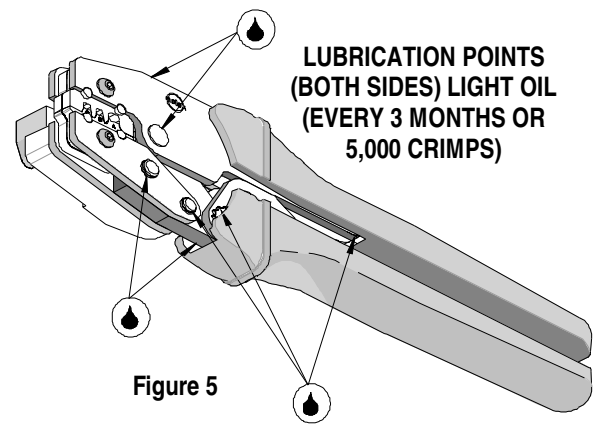

Figure 5

Miscrimps or Jams

Should this tool ever become stuck or jammed in a partially closed position, **Do Not force the handles open or closed.** The tool will open easily by pressing the ratchet release lever. See Figure 6.

How To Adjust Tool Preload (See Figure 6)

This hand tool is factory preset to 25-45 LBS. preload. It may be necessary over the life of the tool to adjust tool handle preload force. Listed below are the steps required to adjust the crimping force of the hand tool to obtain proper crimp conditions:

Listed below are the steps required to adjust the crimping force of the hand tool to obtain proper crimp conditions:

1. Remove or fold back the handle grip from the handle to expose the eccentric axle and setting wheel.
2. Remove the locking screw with a 2mm hex wrench. The wrench set (63810-0101), is not supplied. It is sold separately from the hand tool.
3. Turn the eccentric axle and setting wheel with the wrench or pliers Counter-clockwise (CCW) will increase handle force.
4. Replace the locking screw, aligning the nearest notch in the setting wheel to locking screw.
5. Replace the handle grip.
6. Check the crimp specifications or conduct a pull test after tool handle preload force is adjusted.

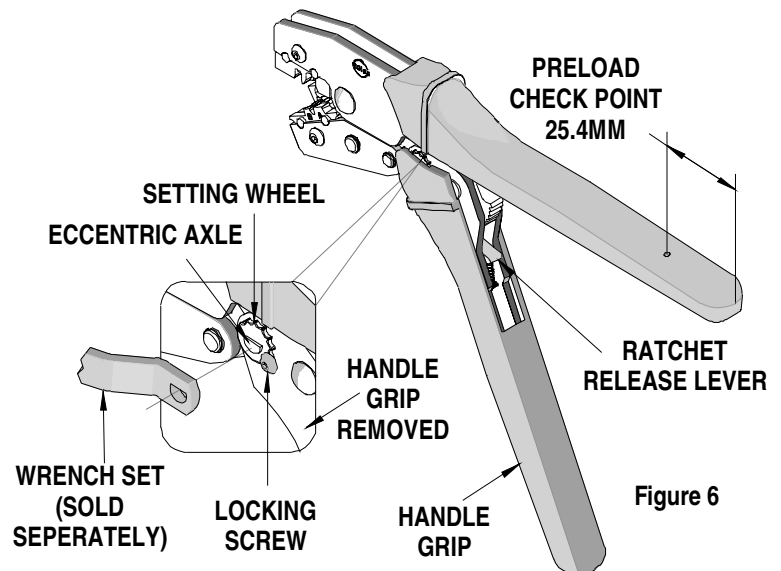

Figure 6

Warranty

This tool is for electrical terminal crimping purposes only. This tool is made of the best quality materials. All vital components are long life tested. All tools are warranted to be free of manufacturing defects for a period of 30 days. Should such a defect occur, we will repair or exchange the tool free of charge. This repair or exchange will not be applicable to altered, misused, or damaged tools. This tool is designed for hand use only. Any clamping, fixturing, or use of handle extensions voids this warranty.

CAUTION: Molex crimp specifications are valid only when used with Molex terminals and tooling.

CAUTIONS

1. Manually powered hand tools are intended for low volume or field repair. This tool is **NOT** intended for production use. Repetitive use of this tool should be avoided.
2. Insulated rubber handles are not protection against electrical shock.
3. Wear eye protection at all times.
4. Use only the Molex terminals specified for crimping with this tool.

Certification

Molex does not certify or re-certify commercial grade hand tools but rather supplies the following guidelines for customers to re-certify hand tools.

- This tool is qualified to pull force only. To re-certify, crimp a terminal to a wire, which has been stripped 12.7mm (1/2") long, so there is no crimping of the insulation. Pull the terminal and wire at a rate no faster than 25mm (1.00") per minute. See the Molex web site for the Quality Crimp Handbook for more information on pull testing.
- If the tool does not meet minimum pull force values, handle preload should be increased and the pull test rerun, (See How To Adjust Preload).
- When the hand tool is no longer capable of achieving minimum pull force, it should be taken out of service and replaced.

PARTS LIST

Item Number	Order Number	Description	Quantity
1	63810-0101	Wrench Set (Not included)	0
2	63810-0102	Locator Base Assembly	1
3	63810-0103	Repair Kit (Not included)	0
4	63811-5275	Locator #1-Black	1
5	63811-5276	Locator #2-Gray	1

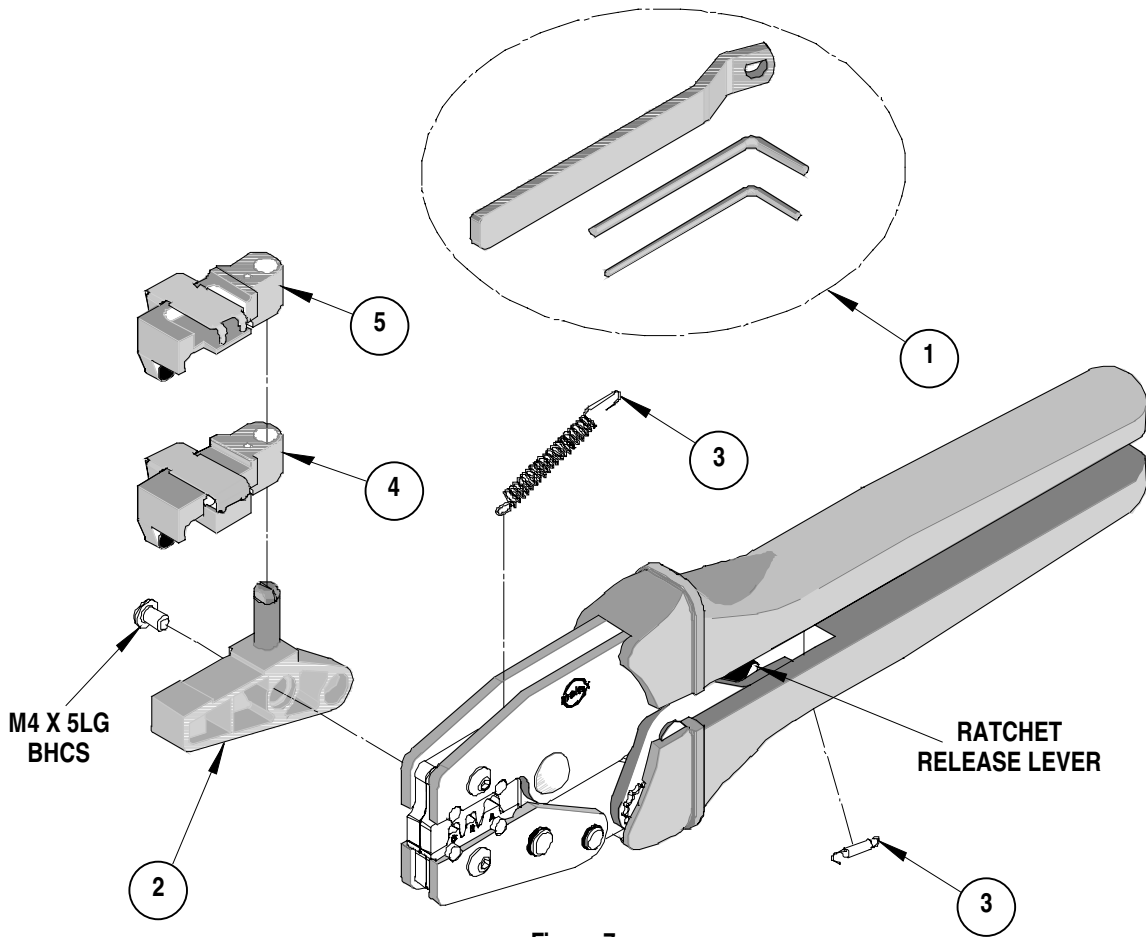

Figure 7

Americas Headquarters
 Lisle, Illinois 60532 U.S.A.
 1-800-78MOLEX
 amerinfo@molex.com

Far East North Headquarters
 Yamato, Kanagawa, Japan
 81-462-65-2324
 feninfo@molex.com

Far East South Headquarters
 Jurong, Singapore
 65-6-268-6868
 fesinfo@molex.com

European Headquarters
 Munich, Germany
 49-89-413092-0
 eurinfo@molex.com

Corporate Headquarters
 2222 Wellington Ct.
 Lisle, IL 60532 U.S.A.
 630-969-4550
 Fax: 630-969-1352

Visit our Web site at <http://www.molex.com>