

P/N	WIRE SIZE (mm <sup>2</sup> )	INSULATION DIAMETER	A	B	C	D	GAP	TAB THICKNESS
94510-0103	0.35 - 0.50	1.70 MAX	1.9	2.2	2.7	2.7	0.3 (±0.15)	0.80
94510-0203	0.75 - 1.00	2.10 MAX	3.0	2.9	2.8	2.9	0.3 (±0.15)	0.80
94510-2103	0.35 - 0.50	1.70 MAX	1.9	2.2	2.7	2.7	0.1 (+0.15/-0.1)	0.63

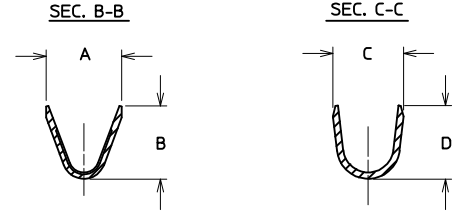
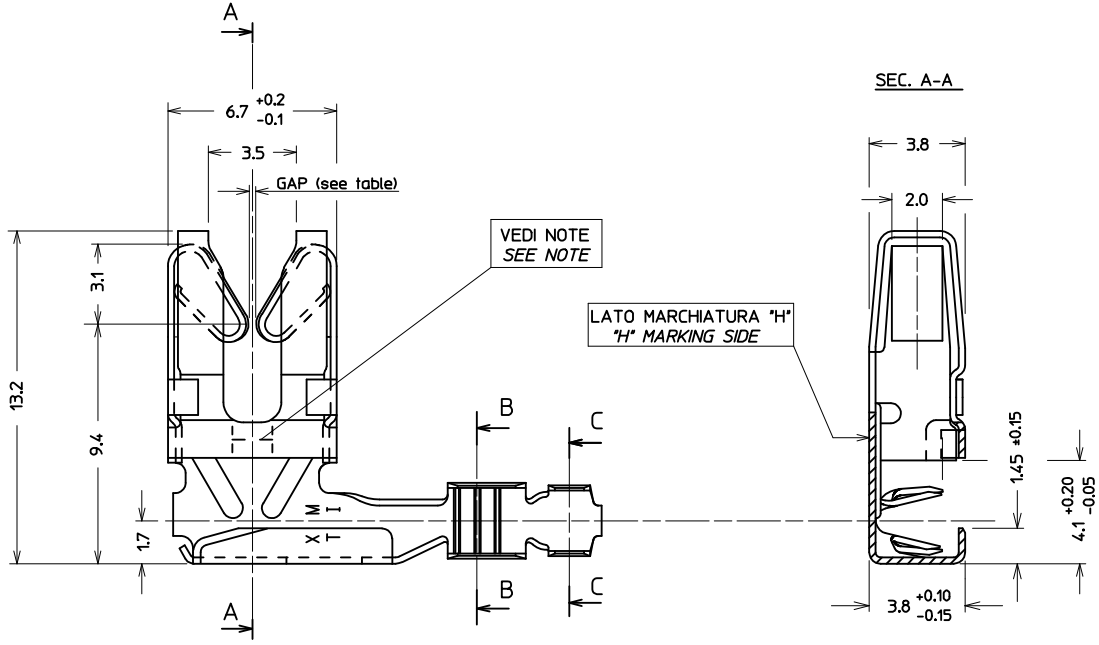

NOTE: MARCHIATURA "H" = TERMINALE CON GAP 0.3 mm  
 SENZA MARCHIATURA = TERMINALE CON GAP 0.1 mm  
 PASSO TRA TERMINALI ADIACENTI = 21.3 mm

NOTE: MARK "H" = TERMINAL WITH 0.3 mm GAP  
 NO MARK = TERMINAL WITH 0.1 mm GAP  
 PITCH BETWEEN ADJACENT TERMINALS = 21.3 mm

MATERIALE: BRONZO FOSFOROSO B6 DURO (H04)  
 FINITURA: PRESTAGNATO (HOT-DIP TIN) 3 ↔ 6 μm  
 IMBALLO: 2700 pz./bobina ; nr.7 bobine/Box ; Tot. 18900 pz. (SPQ)  
 Caratteristiche di Prodotto in accordo a: PS-94509-002

MATERIAL: PHOSPHOR BRONZE B6 HARD (TEMPER H04)  
 PLATING: PRE-TINNED (HOT-DIP TIN) 3 ↔ 6 μm  
 PACKAGING: 2700 pcs/reel ; nr. 7 reels/Box ; Tot. 18900 pcs. (SPQ)  
 Product characteristics according to: PS-94509-002

SENSO DI SVOLGIMENTO DALLA BOBINA  
 DEREEING DIRECTION

ENTER DESCRIPTION EC NO: Z2013-0171 DRWN:LSANTESS 2013/06/12 CHKD:LSANTESS 2014/04/02 APPR:FBISELLO 2014/04/02	QUALITY SYMBOLS	GENERAL TOLERANCES (UNLESS SPECIFIED)	DIMENSION STYLE	SCALE	DESIGN UNITS	FIRST ANGLE PROJECTION	
	$F_A=0$ $F_C=0$ $F_P=0$	mm INCH 4 PLACES ± --- ± --- 3 PLACES ± --- ± --- 2 PLACES ± --- ± --- 1 PLACE ± 0.2 ± --- 0 PLACE ± ±	MM ONLY	SCALE	METRIC	DRAWN BY DATE LSANTESS 2013/06/12 CHECKED BY DATE LSANTESS 2014/04/02 APPROVED BY DATE FBISELLO 2014/04/02	TITLE
	ANGULAR ± 3 ° DRAFT WHERE APPLICABLE MUST REMAIN WITHIN DIMENSIONS	SEE TABLE	MATERIAL NO. DOCUMENT NO.	R/A FORK TERMINAL 0,63 AND 0,80 TAB THICK.		molex SD-94510-003	SHEET NO. 1 OF 00
	A1	SIZE A3 THIS DRAWING CONTAINS INFORMATION THAT IS PROPRIETARY TO MOLEX INCORPORATED AND SHOULD NOT BE USED WITHOUT WRITTEN PERMISSION					