

DRV5033 Digital-Omnipolar-Switch Hall Effect Sensor

1 Features

- Digital Omnipolar-Switch Hall Sensor
- Superior Temperature Stability
 - $B_{OP} \pm 10\%$ Over Temperature
- Multiple Sensitivity Options (B_{OP} / B_{RP}):
 - $\pm 3.5 / \pm 2$ mT (FA, see [Device Nomenclature](#))
 - $\pm 6.9 / \pm 3.5$ mT (AJ, see [Device Nomenclature](#))
- Detects North and South Magnetic Field
- Supports a Wide Voltage Range
 - 2.5 to 38 V
 - No External Regulator Required
- Wide Operating Temperature Range
 - $T_A = -40$ to 125°C (Q, see [Device Nomenclature](#))
- Open Drain Output (30-mA Sink)
- Fast 35- μs Power-On Time
- Small Package and Footprint
 - Surface Mount 3-Pin SOT-23 (DBZ)
 - 2.92 mm \times 2.37 mm
 - Through-Hole 3-Pin TO-92 (LPG)
 - 4.00 mm \times 3.15 mm
- **Protection Features**
 - Reverse Supply Protection (up to -22 V)
 - Supports up to 40-V Load Dump
 - Output Short-Circuit Protection
 - Output Current Limitation

2 Applications

- Docking Detection
- Door Open and Close Detection
- Proximity Sensing
- Valve Positioning
- Pulse Counting

3 Description

The DRV5033 device is a chopper-stabilized Hall Effect Sensor that offers a magnetic sensing solution with superior sensitivity stability over temperature and integrated protection features.

The DRV5033 responds the same to both polarities of magnetic field direction. When the applied magnetic flux density exceeds the B_{OP} threshold, the DRV5033 open-drain output goes low. The output stays low until the field decreases to less than B_{RP} , and then the output goes to high impedance. The output current sink capability is 30 mA. A wide operating voltage range from 2.5 to 38 V with reverse polarity protection up to -22 V makes the device suitable for a wide range of industrial applications.

Internal protection functions are provided for reverse supply conditions, load dump, and output short circuit or over current.

Device Information⁽¹⁾

PART NUMBER	PACKAGE	BODY SIZE (NOM)
DRV5033	SOT-23 (3)	2.92 mm \times 1.30 mm
	TO-92 (3)	4.00 mm \times 3.15 mm

(1) For all available packages, see the orderable addendum at the end of the data sheet.

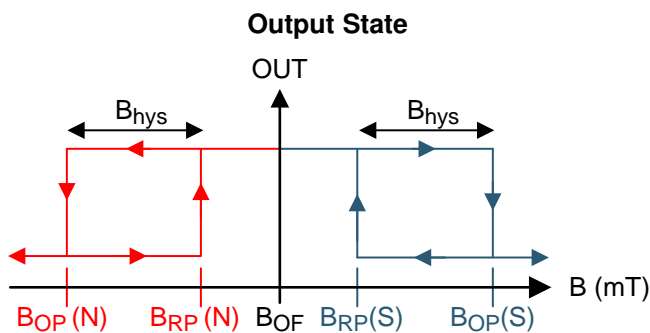

Device Packages

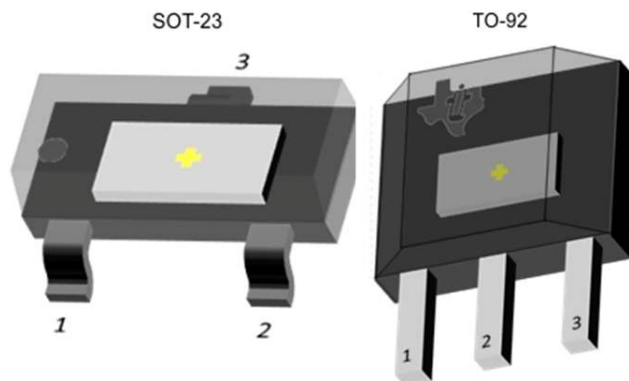

Table of Contents

1 Features	1	7.3 Feature Description.....	10
2 Applications	1	7.4 Device Functional Modes.....	15
3 Description	1	8 Application and Implementation	16
4 Revision History	2	8.1 Application Information.....	16
5 Pin Configuration and Functions	4	8.2 Typical Applications	16
6 Specifications	5	9 Power Supply Recommendations	18
6.1 Absolute Maximum Ratings	5	10 Layout	19
6.2 ESD Ratings.....	5	10.1 Layout Guidelines	19
6.3 Recommended Operating Conditions.....	5	10.2 Layout Example	19
6.4 Thermal Information	5	11 Device and Documentation Support	20
6.5 Electrical Characteristics.....	6	11.1 Device Support.....	20
6.6 Switching Characteristics	6	11.2 Receiving Notification of Documentation Updates	21
6.7 Magnetic Characteristics.....	6	11.3 Community Resources.....	21
6.8 Typical Characteristics	7	11.4 Trademarks	21
7 Detailed Description	9	11.5 Electrostatic Discharge Caution.....	21
7.1 Overview	9	11.6 Glossary	21
7.2 Functional Block Diagram	9	12 Mechanical, Packaging, and Orderable Information	21

4 Revision History

NOTE: Page numbers for previous revisions may differ from page numbers in the current version.

Changes from Revision F (May 2016) to Revision G	Page
• Changed the power-on time for the FA version in the <i>Electrical Characteristics</i> table	6
• Added the <i>Layout</i> section	19
• Added the <i>Receiving Notification of Documentation Updates</i> section	21

Changes from Revision E (February 2016) to Revision F	Page
• Revised preliminary limits for the FA version	6

Changes from Revision D (December 2015) to Revision E	Page
• Added the FA device option	1
• Added the typical bandwidth value to the <i>Magnetic Characteristics</i> table	6

Changes from Revision C (May 2015) to Revision D	Page
• Corrected body size of SOT-23 package and SIP package name to TO-92	1
• Added B_{MAX} to <i>Absolute Maximum Ratings</i>	5
• Removed table note from junction temperature	5
• Updated package tape and reel options for M and blank	20
• Added Community Resources	21

Changes from Revision B (September 2014) to Revision C	Page
• Updated device status to production data	1

Changes from Revision A (August 2014) to Revision B	Page
--	-------------

• Changed the maximum T_J value to 150°C	5
• Added typical rise and fall time and removed maximum value in Switching Characteristics	6
• Updated the <i>Magnetic Characteristics</i> values	6
• Updated all <i>Typical Characteristics</i> graphs	7
• Updated Equation 4	17

Changes from Original (May 2014) to Revision A	Page
---	-------------

• Changed High Sensitivity Options: +6.9 / +2.3 mT (AJ) to +6.9 / +3.5 mT (AJ)	1
• Changed the maximum T_J value from 175°C to 150°C.....	5
• Changed MIN value for I_{OCP} from 20 to 15	6
• Changed Max value for I_{OCP} from 40 to 45	6
• Updated <i>Magnetic Characteristics</i> table.	6

5 Pin Configuration and Functions

For additional configuration information, see [Device Markings](#) and [Mechanical, Packaging, and Orderable Information](#).

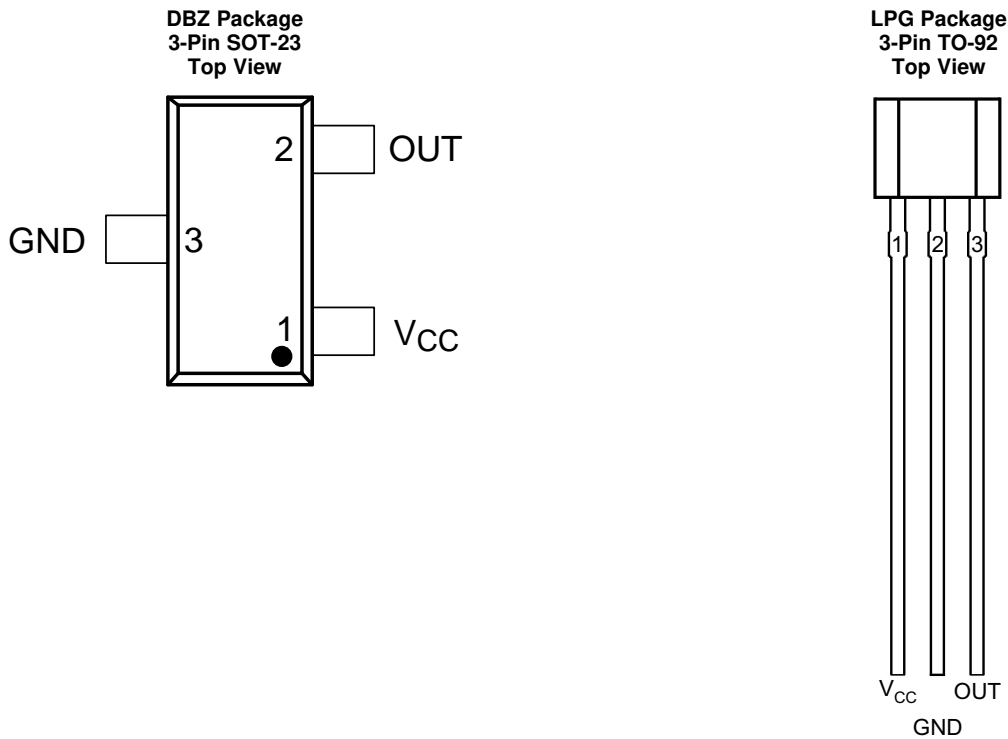

Pin Functions

NAME	PIN		TYPE	DESCRIPTION
	DBZ	LPG		
GND	3	2	GND	Ground pin
OUT	2	3	Output	Hall sensor open-drain output. The open drain requires a resistor pullup.
V _{CC}	1	1	PWR	2.5 to 38 V power supply. Bypass this pin to the GND pin with a 0.01- μ F (minimum) ceramic capacitor rated for V _{CC} .

6 Specifications

6.1 Absolute Maximum Ratings

over operating free-air temperature range (unless otherwise noted) ⁽¹⁾

		MIN	MAX	UNIT
Power supply voltage	V _{CC}	-22 ⁽²⁾	40	V
	Voltage ramp rate (V _{CC}), V _{CC} < 5 V	Unlimited		V/μs
	Voltage ramp rate (V _{CC}), V _{CC} > 5 V	0	2	
Output pin voltage		-0.5	40	V
Output pin reverse current during reverse supply condition		0	100	mA
Magnetic flux density, B _{MAX}		Unlimited		
Operating junction temperature, T _J		-40	150	°C
Storage temperature, T _{stg}		-65	150	°C

- (1) Stresses beyond those listed under *Absolute Maximum Ratings* may cause permanent damage to the device. These are stress ratings only, which do not imply functional operation of the device at these or any other conditions beyond those indicated under *Recommended Operating Conditions*. Exposure to absolute-maximum-rated conditions for extended periods may affect device reliability.
- (2) Ensured by design. Only tested to -20 V.

6.2 ESD Ratings

			VALUE	UNIT
V _(ESD)	Electrostatic discharge	Human body model (HBM), per ANSI/ESDA/JEDEC JS-001, all pins ⁽¹⁾	±2500	V
		Charged device model (CDM), per JEDEC specification JESD22-C101, all pins ⁽²⁾	±500	

- (1) JEDEC document JEP155 states that 500-V HBM allows safe manufacturing with a standard ESD control process.
- (2) JEDEC document JEP157 states that 250-V CDM allows safe manufacturing with a standard ESD control process.

6.3 Recommended Operating Conditions

over operating free-air temperature range (unless otherwise noted)

		MIN	MAX	UNIT
V _{CC}	Power supply voltage	2.5	38	V
V _O	Output pin voltage (OUT)	0	38	V
I _{SINK}	Output pin current sink (OUT) ⁽¹⁾	0	30	mA
T _A	Operating ambient temperature	-40	125	°C

- (1) Power dissipation and thermal limits must be observed

6.4 Thermal Information

THERMAL METRIC ⁽¹⁾	DRV5033		UNIT	
	DBZ (SOT-23)	LPG (TO-92)		
	3 PINS	3 PINS		
R _{θJA}	Junction-to-ambient thermal resistance	333.2	180	°C/W
R _{θJC(top)}	Junction-to-case (top) thermal resistance	99.9	98.6	°C/W
R _{θJB}	Junction-to-board thermal resistance	66.9	154.9	°C/W
ψ _{JT}	Junction-to-top characterization parameter	4.9	40	°C/W
ψ _{JB}	Junction-to-board characterization parameter	65.2	154.9	°C/W

- (1) For more information about traditional and new thermal metrics, see the *Semiconductor and IC Package Thermal Metrics* application report, [SPRA953](#).

6.5 Electrical Characteristics

over operating free-air temperature range (unless otherwise noted)

PARAMETER		TEST CONDITIONS	MIN	TYP	MAX	UNIT
POWER SUPPLIES (V_{CC})						
V _{CC}	V _{CC} operating voltage		2.5		38	V
I _{CC}	Operating supply current	V _{CC} = 2.5 to 38 V, T _A = 25°C		2.7		mA
		V _{CC} = 2.5 to 38 V, T _A = 125°C		3	3.6	
t _{on}	Power-on time	AJ version		35	50	μs
		FA version		35	70	
OPEN DRAIN OUTPUT (OUT)						
r _{DS(on)}	FET on-resistance	V _{CC} = 3.3 V, I _O = 10 mA, T _A = 25°C		22		Ω
		V _{CC} = 3.3 V, I _O = 10 mA, T _A = 125°C		36	50	
I _{lkg(off)}	Off-state leakage current	Output Hi-Z			1	μA
PROTECTION CIRCUITS						
V _{CCR}	Reverse supply voltage		-22			V
I _{OCF}	Overcurrent protection level	OUT shorted V _{CC}	15	30	45	mA

6.6 Switching Characteristics

over operating free-air temperature range (unless otherwise noted)

PARAMETER		TEST CONDITIONS	MIN	TYP	MAX	UNIT
OPEN DRAIN OUTPUT (OUT)						
t _d	Output delay time	B = B _{RP} - 10 mT to B _{OP} + 10 mT in 1 μs		13	25	μs
t _r	Output rise time (10% to 90%)	R1 = 1 kΩ, C _O = 50 pF, V _{CC} = 3.3 V		200		ns
t _f	Output fall time (90% to 10%)	R1 = 1 kΩ, C _O = 50 pF, V _{CC} = 3.3 V		31		ns

6.7 Magnetic Characteristics

over operating free-air temperature range (unless otherwise noted)

PARAMETER		TEST CONDITIONS	MIN	TYP	MAX	UNIT ⁽¹⁾
f _{BW}	Bandwidth ⁽²⁾		20	30		kHz
DRV5033FA: ±3.5 / ±2 mT						
B _{OP}	Operate point; see Figure 12	T _A = -40°C to 125°C	±1.8	±3.5	±6.8	mT
B _{RP}	Release point; see Figure 12		±0.5	±2	±4.2	mT
B _{hys}	Hysteresis; B _{hys} = (B _{OP} - B _{RP}) ⁽³⁾			±1.5		mT
B _O	Magnetic offset; B _O = (B _{OP} + B _{RP}) / 2			±2.8		mT
DRV5033AJ: ±6.9 / ±3.5 mT						
B _{OP}	Operate point; see Figure 12	T _A = -40°C to 125°C	±3	±6.9	±12	mT
B _{RP}	Release point; see Figure 12		±1	±3.5	±5	mT
B _{hys}	Hysteresis; B _{hys} = (B _{OP} - B _{RP}) ⁽³⁾			3.4		mT
B _O	Magnetic offset; B _O = (B _{OP} + B _{RP}) / 2			5.2		mT

(1) 1 mT = 10 Gauss

(2) Bandwidth describes the fastest changing magnetic field that can be detected and translated to the output.

 (3) |B_{OP}| is always greater than |B_{RP}|.

6.8 Typical Characteristics

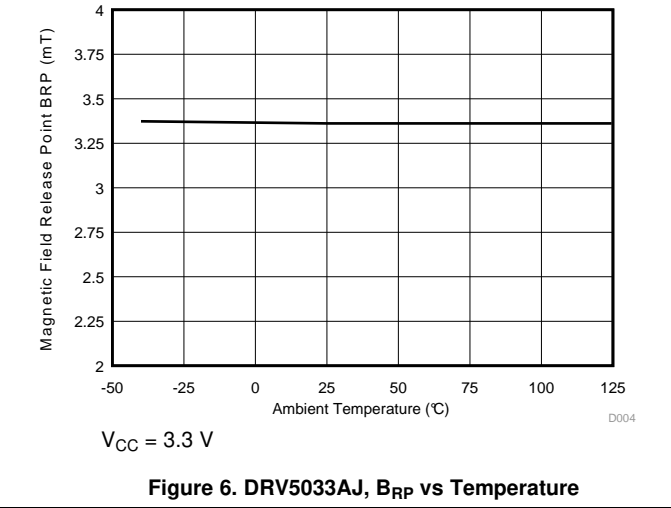
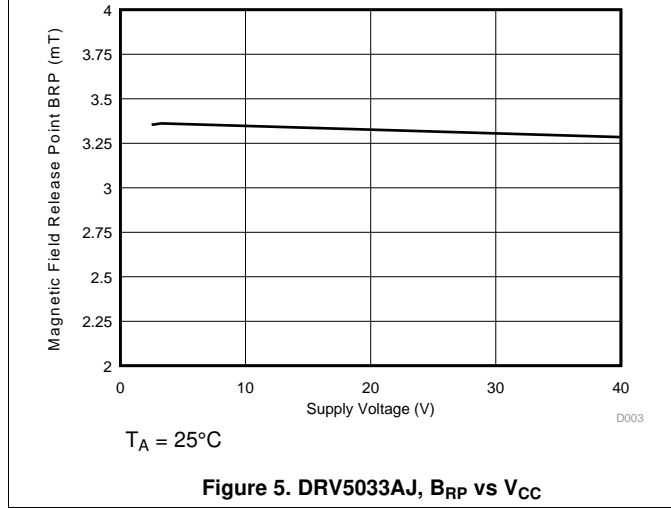
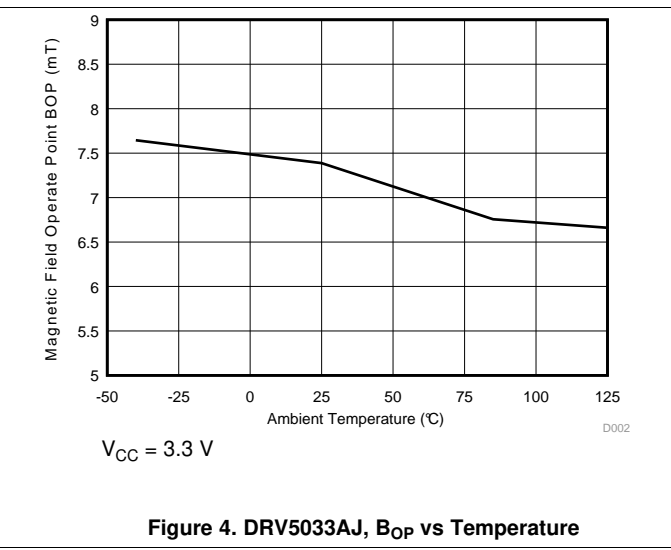
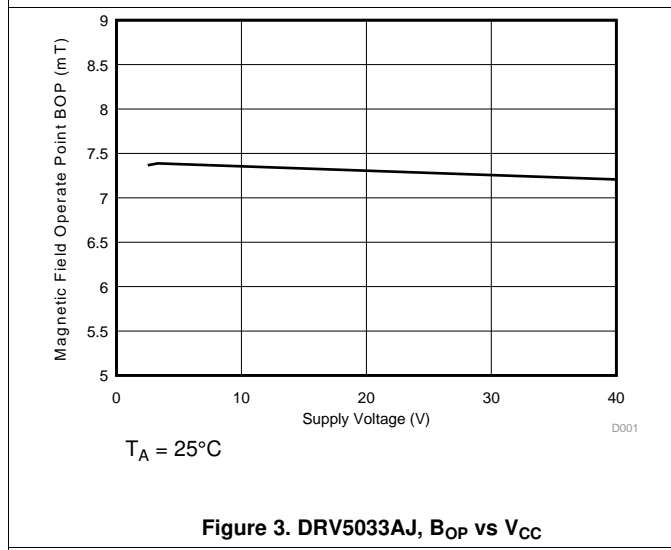
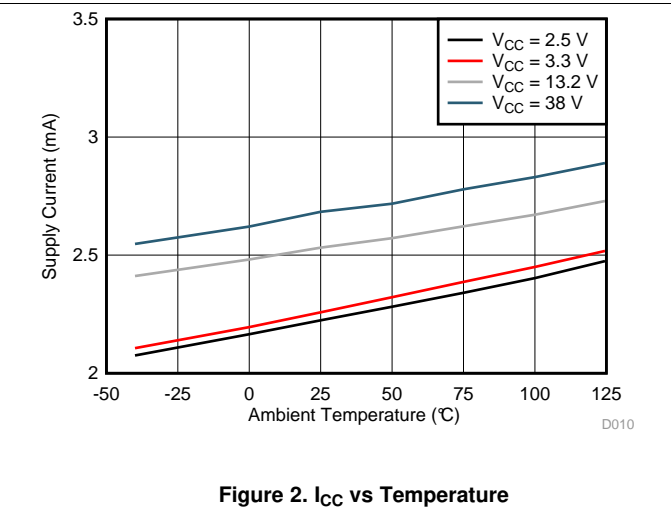
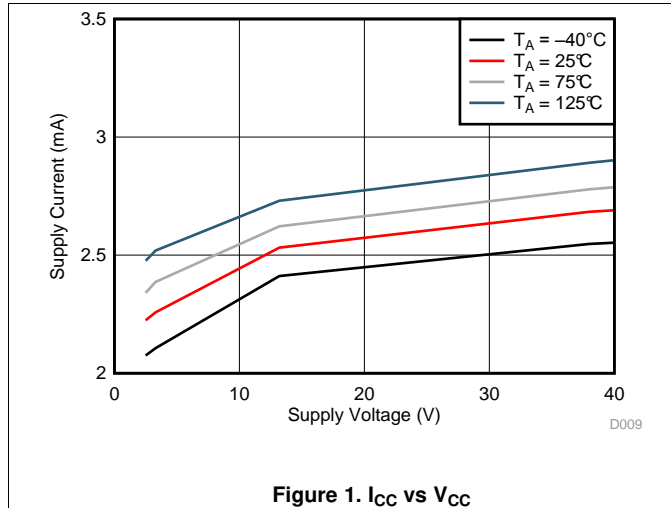

Typical Characteristics (continued)

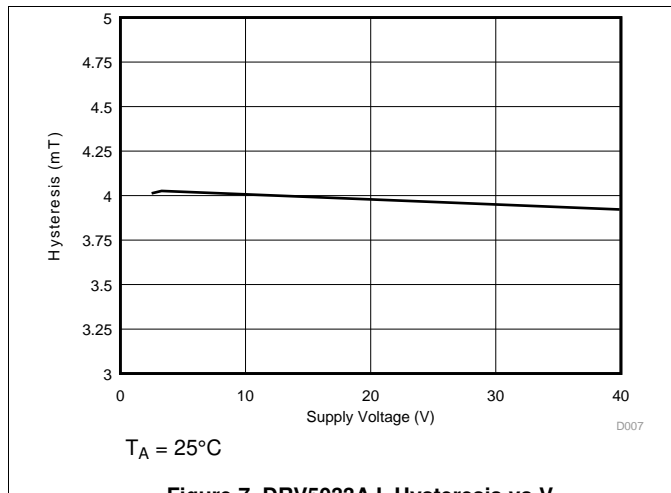

Figure 7. DRV5033AJ, Hysteresis vs V_{CC}

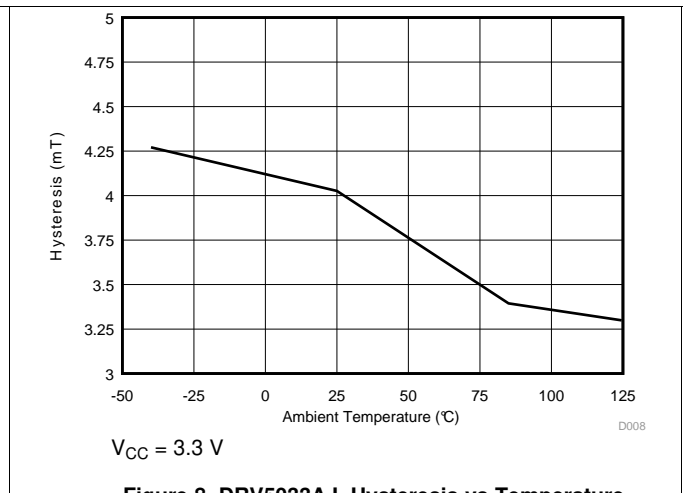

Figure 8. DRV5033AJ, Hysteresis vs Temperature

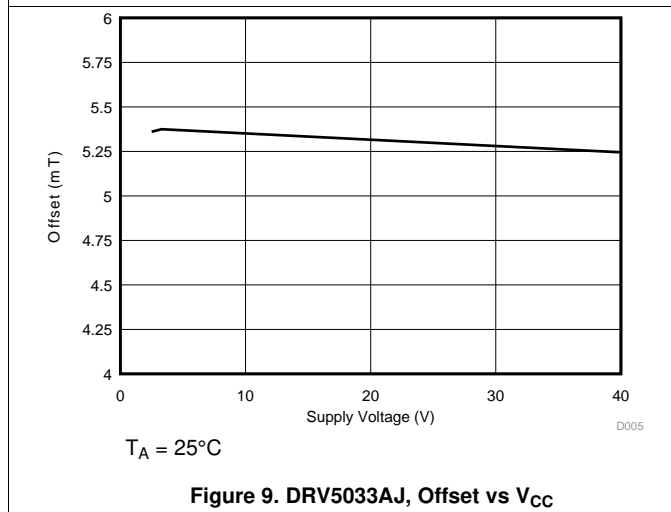

Figure 9. DRV5033AJ, Offset vs V_{CC}

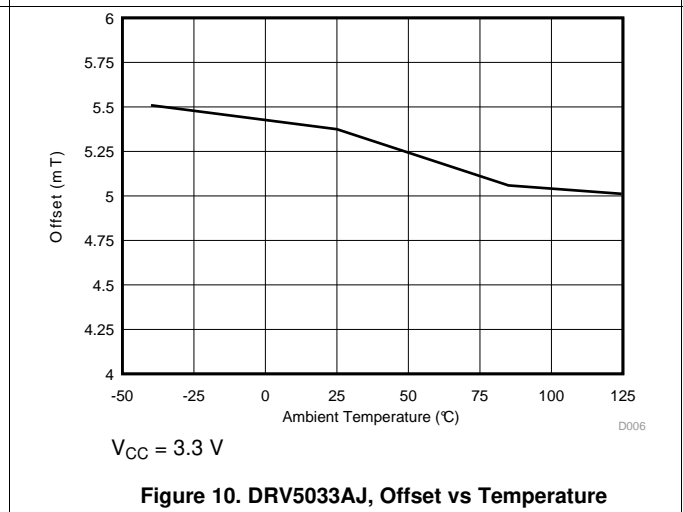

Figure 10. DRV5033AJ, Offset vs Temperature

7 Detailed Description

7.1 Overview

The DRV5033 device is a chopper-stabilized hall sensor with a digital omnipolar switch output for magnetic sensing applications. The DRV5033 device can be powered with a supply voltage between 2.5 and 38 V, and will survive -22 V reverse battery conditions continuously. Note that the DRV5033 device will not be operating when about -22 to 2.4 V is applied to V_{CC} (with respect to GND). In addition, the device can withstand voltages up to 40 V for transient durations.

The field polarity is defined as follows: a **south pole** near the marked side of the package is a **positive magnetic field**. A **north pole** near the marked side of the package is a **negative magnetic field**.

The omnipolar configuration allows the hall sensor to respond to either a south or north pole. A strong magnetic field of either polarity will cause the output to pull low (operate point, B_{OP}), and a weaker magnetic field will cause the output to release (release point, B_{RP}). Hysteresis is included in between the operate and release points, so magnetic field noise will not trip the output accidentally.

An external pullup resistor is required on the OUT pin. The OUT pin can be pulled up to V_{CC} , or to a different voltage supply. This allows for easier interfacing with controller circuits.

7.2 Functional Block Diagram

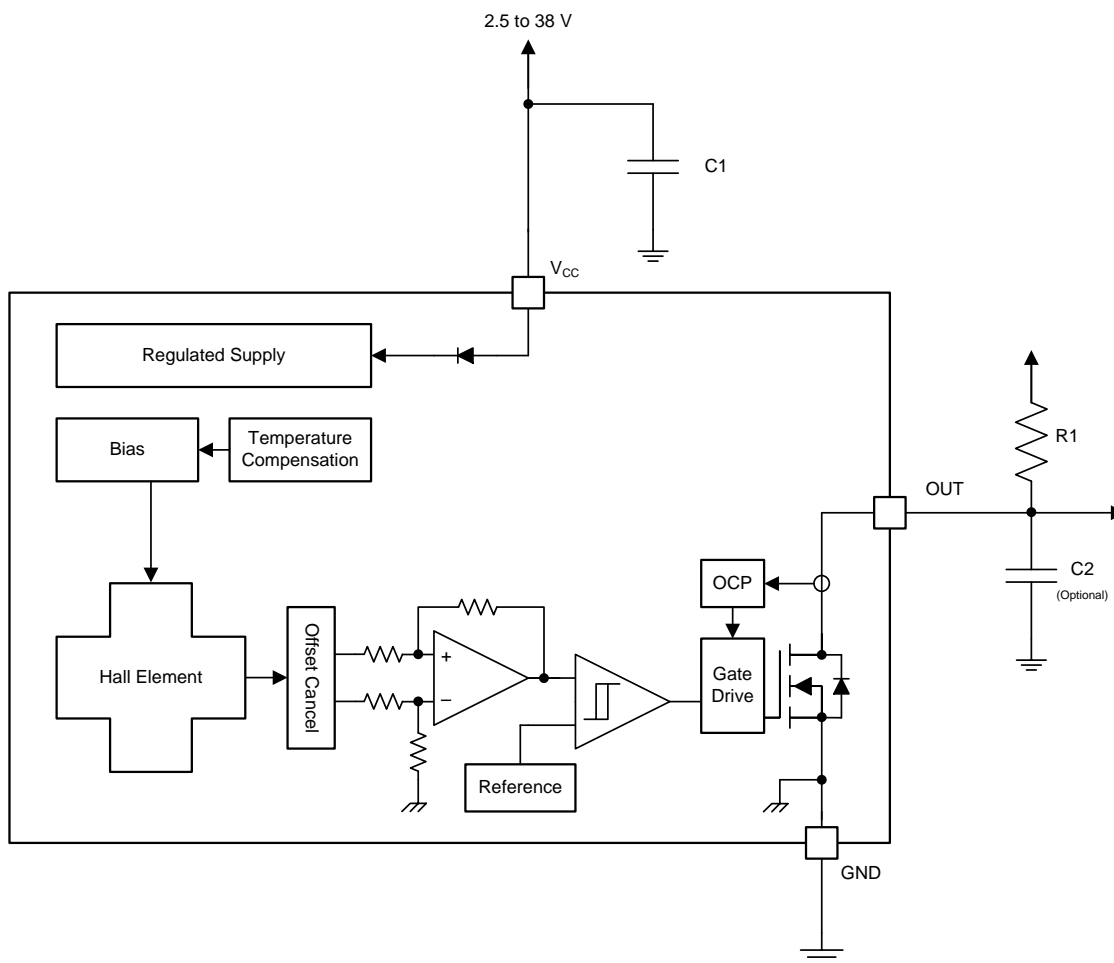

7.3 Feature Description

7.3.1 Field Direction Definition

A positive magnetic field is defined as a **south pole** near the marked side of the package as shown in [Figure 11](#).

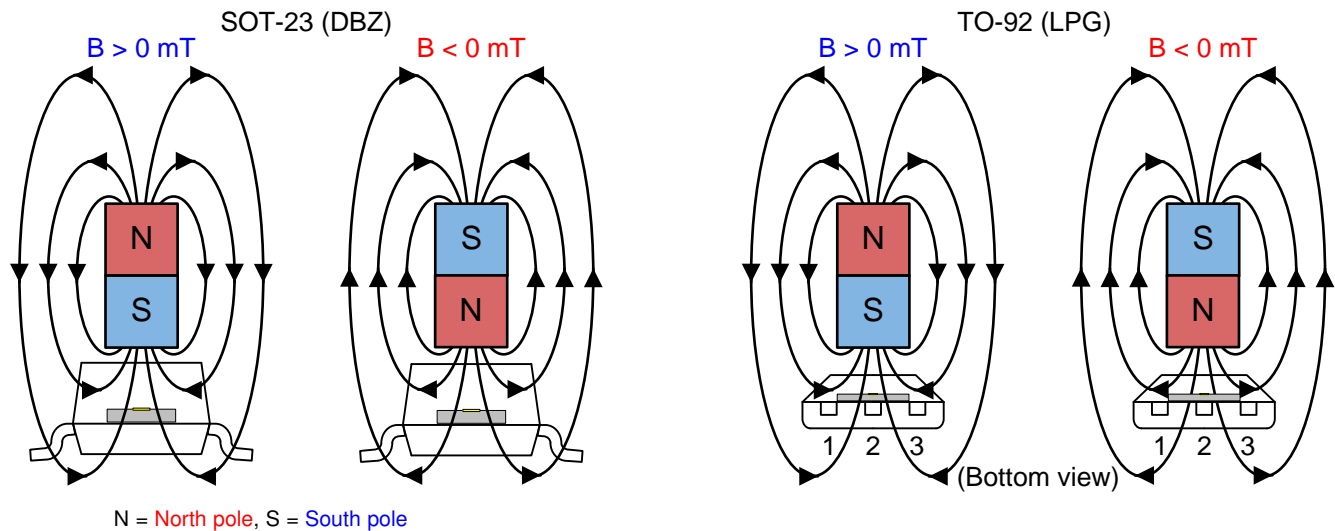

Figure 11. Field Direction Definition

7.3.2 Device Output

If the device is powered on with a magnetic field strength between B_{RP} and B_{OP} , then the device output is indeterminate and can either be Hi-Z or Low. If the field strength is greater than B_{OP} , then the output is pulled low. If the field strength is less than B_{RP} , then the output is released.

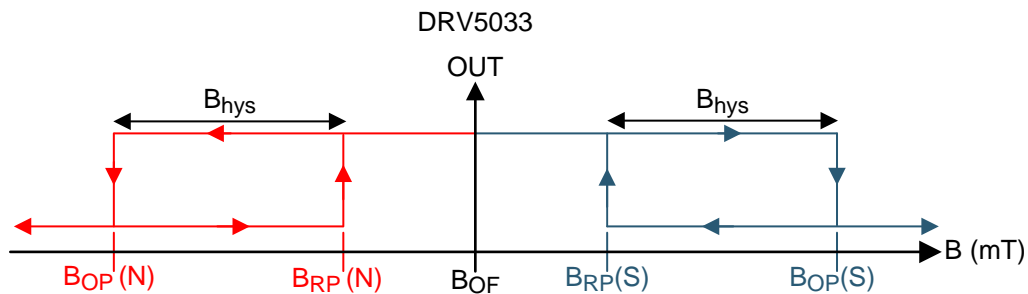

Figure 12. DRV5033— $B_{OP} > 0$

Feature Description (continued)

7.3.3 Power-On Time

After applying V_{CC} to the DRV5033 device, t_{on} must elapse before the OUT pin is valid. During the power-up sequence, the output is Hi-Z. A pulse as shown in Figure 13 and Figure 14 occurs at the end of t_{on} . This pulse can allow the host processor to determine when the DRV5033 output is valid after startup. In Case 1 (Figure 13) and Case 2 (Figure 14), the output is defined assuming a constant magnetic field $B > B_{OP}$ and $B < B_{RP}$.

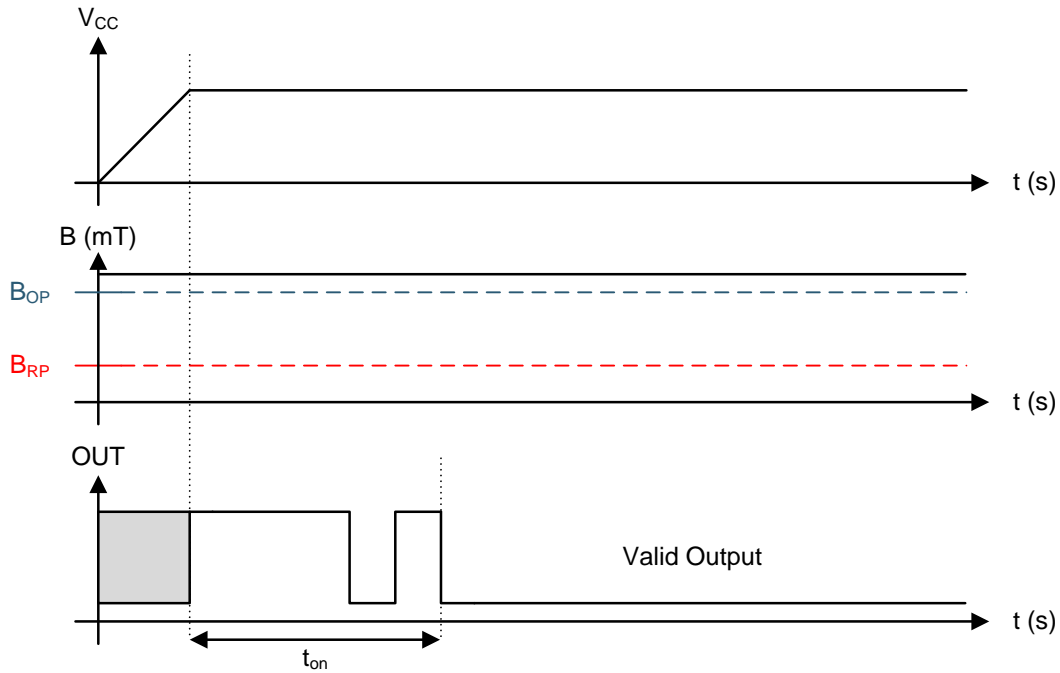

Figure 13. Case 1: Power On When $B > B_{OP}$

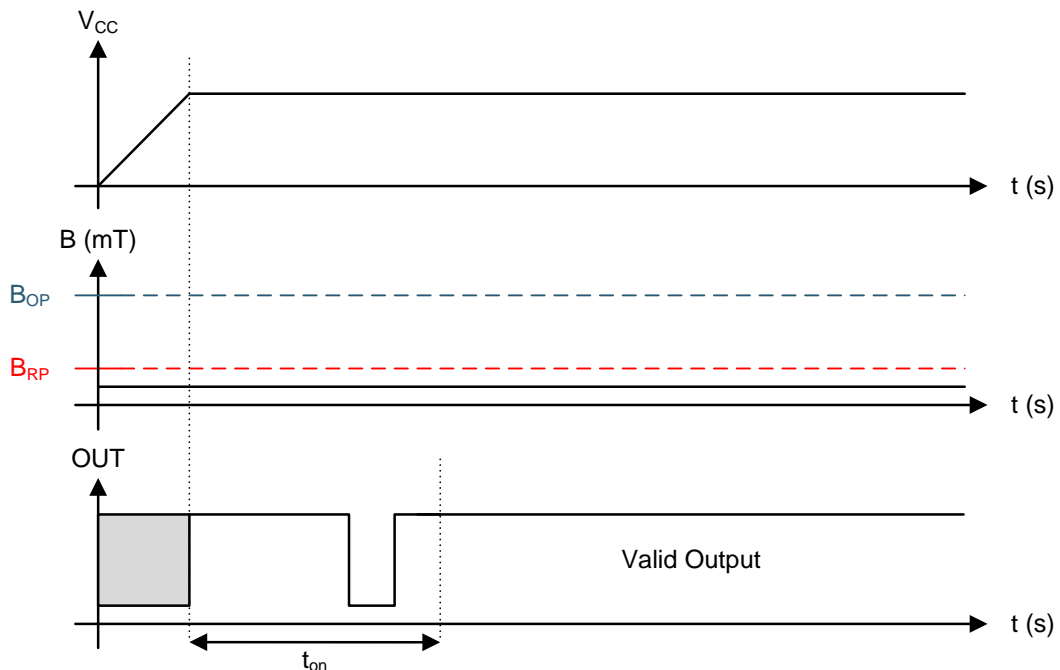

Figure 14. Case 2: Power On When $B < B_{RP}$

Feature Description (continued)

If the device is powered on with the magnetic field strength $B_{RP} < B < B_{OP}$, then the device output is indeterminate and can either be Hi-Z or pulled low. During the power-up sequence, the output is held Hi-Z until t_{on} has elapsed. At the end of t_{on} , a pulse is given on the OUT pin to indicate that t_{on} has elapsed. After t_{on} , if the magnetic field changes such that $B_{OP} < B$, the output is released. Case 3 (Figure 15) and Case 4 (Figure 16) show examples of this behavior.

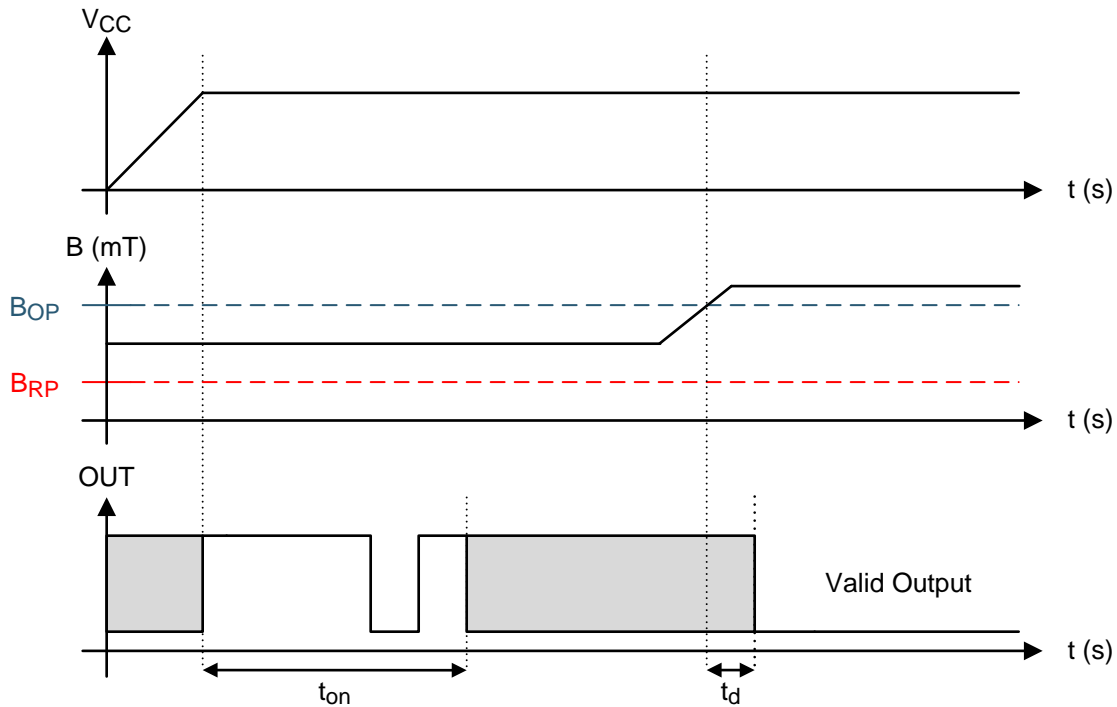

Figure 15. Case 3: Power On When $B_{RP} < B < B_{OP}$, Followed by $B > B_{OP}$

Feature Description (continued)

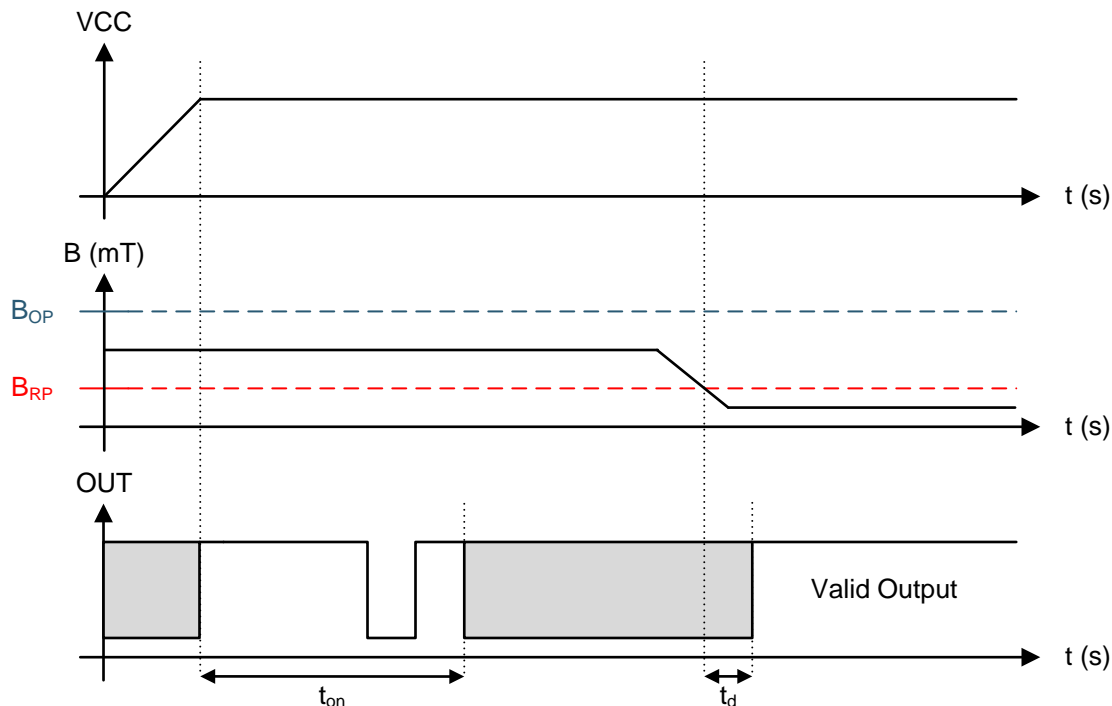

Figure 16. Case 4: Power On When B_{RP} < B < B_{OP}, Followed by B < B_{RP}

7.3.4 Output Stage

The DRV5033 output stage uses an open-drain NMOS, and it is rated to sink up to 30 mA of current. For proper operation, calculate the value of the pullup resistor R1 using Equation 1.

$$\frac{V_{ref \ max}}{30 \text{ mA}} \leq R1 \leq \frac{V_{ref \ min}}{100 \ \mu\text{A}} \tag{1}$$

The size of R1 is a tradeoff between the OUT rise time and the current when OUT is pulled low. A lower current is generally better, however faster transitions and bandwidth require a smaller resistor for faster switching.

In addition, ensure that the value of R1 > 500 Ω to ensure the output driver can pull the OUT pin close to GND.

NOTE

V_{ref} is not restricted to V_{CC}. The allowable voltage range of this pin is specified in the [Absolute Maximum Ratings](#).

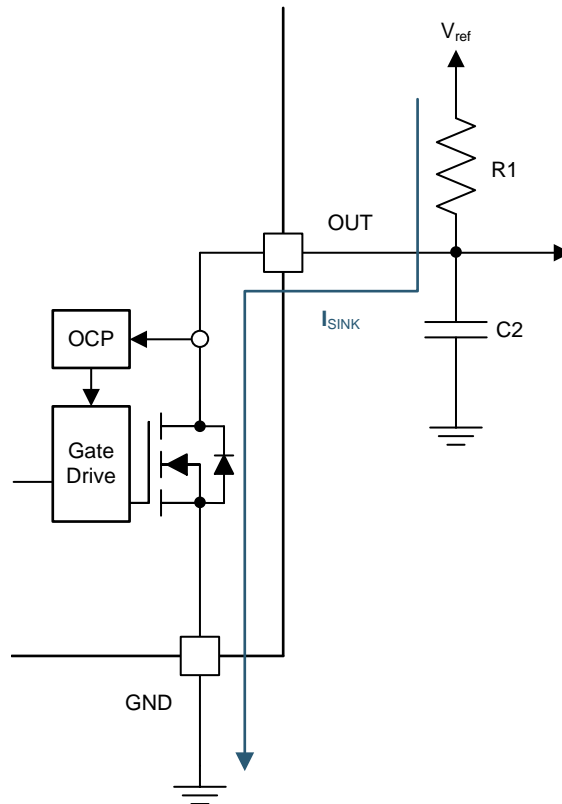
Feature Description (continued)

Figure 17.

Select a value for C2 based on the system bandwidth specifications as shown in [Equation 2](#).

$$2 \times f_{\text{BW}} \text{ (Hz)} < \frac{1}{2\pi \times R1 \times C2} \quad (2)$$

Most applications do not require this C2 filtering capacitor.

Feature Description (continued)

7.3.5 Protection Circuits

The DRV5033 device is fully protected against overcurrent and reverse-supply conditions.

7.3.5.1 Overcurrent Protection (OCP)

An analog current-limit circuit limits the current through the FET. The driver current is clamped to I_{OCP} . During this clamping, the $r_{DS(on)}$ of the output FET is increased from the nominal value.

7.3.5.2 Load Dump Protection

The DRV5033 device operates at DC V_{CC} conditions up to 38 V nominally, and can additionally withstand $V_{CC} = 40$ V. No current-limiting series resistor is required for this protection.

7.3.5.3 Reverse Supply Protection

The DRV5033 device is protected in the event that the V_{CC} pin and the GND pin are reversed (up to -22 V).

NOTE

In a reverse supply condition, the OUT pin reverse-current must not exceed the ratings specified in the [Absolute Maximum Ratings](#).

Table 1.

FAULT	CONDITION	DEVICE	DESCRIPTION	RECOVERY
FET overload (OCP)	$I_{SINK} \geq I_{OCP}$	Operating	Output current is clamped to I_{OCP}	$I_O < I_{OCP}$
Load dump	$38\text{ V} < V_{CC} < 40\text{ V}$	Operating	Device will operate for a transient duration	$V_{CC} \leq 38\text{ V}$
Reverse supply	$-22\text{ V} < V_{CC} < 0\text{ V}$	Disabled	Device will survive this condition	$V_{CC} \geq 2.5\text{ V}$

7.4 Device Functional Modes

The DRV5033 device is active only when V_{CC} is between 2.5 and 38 V.

When a reverse supply condition exists, the device is inactive.

8 Application and Implementation

NOTE

Information in the following applications sections is not part of the TI component specification, and TI does not warrant its accuracy or completeness. TI's customers are responsible for determining suitability of components for their purposes. Customers should validate and test their design implementation to confirm system functionality.

8.1 Application Information

The DRV5033 device is used in magnetic-field sensing applications.

8.2 Typical Applications

8.2.1 Standard Circuit

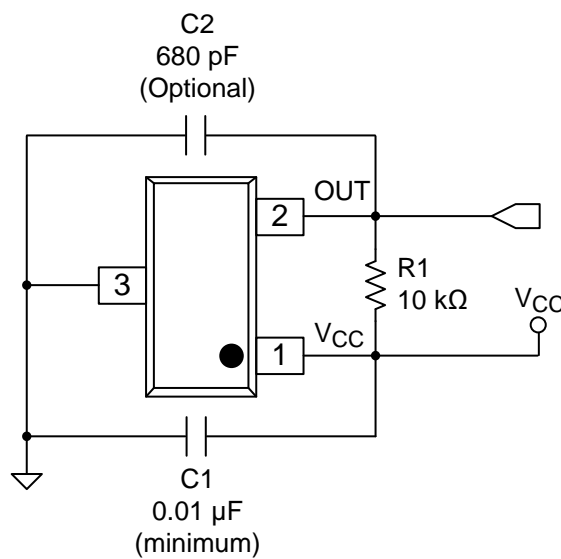

Figure 18. Typical Application Circuit

8.2.1.1 Design Requirements

For this design example, use the parameters listed in Table 2 as the input parameters.

Table 2. Design Parameters

DESIGN PARAMETER	REFERENCE	EXAMPLE VALUE
Supply voltage	V_{CC}	3.2 to 3.4 V
System bandwidth	f_{BW}	10 kHz

8.2.1.2 Detailed Design Procedure

Table 3. External Components

COMPONENT	PIN 1	PIN 2	RECOMMENDED
C1	V_{CC}	GND	A 0.01- μ F (minimum) ceramic capacitor rated for V_{CC}
C2	OUT	GND	Optional: Place a ceramic capacitor to GND
R1	OUT	REF ⁽¹⁾	Requires a resistor pullup

(1) REF is not a pin on the DRV5033 device, but a REF supply-voltage pullup is required for the OUT pin; the OUT pin may be pulled up to V_{CC} .

8.2.1.2.1 Configuration Example

In a 3.3-V system, $3.2\text{ V} \leq V_{\text{ref}} \leq 3.4\text{ V}$. Use Equation 3 to calculate the allowable range for R1.

$$\frac{V_{\text{ref max}}}{30\text{ mA}} \leq R1 \leq \frac{V_{\text{ref min}}}{100\text{ }\mu\text{A}} \tag{3}$$

For this design example, use Equation 4 to calculate the allowable range of R1.

$$\frac{3.4\text{ V}}{30\text{ mA}} \leq R1 \leq \frac{3.2\text{ V}}{100\text{ }\mu\text{A}} \tag{4}$$

Therefore:

$$113\text{ }\Omega \leq R1 \leq 32\text{ k}\Omega \tag{5}$$

After finding the allowable range of R1 (Equation 5), select a value between 500 Ω and 32 k Ω for R1.

Assuming a system bandwidth of 10 kHz, use Equation 6 to calculate the value of C2.

$$2 \times f_{\text{BW}}\text{ (Hz)} < \frac{1}{2\pi \times R1 \times C2} \tag{6}$$

For this design example, use Equation 7 to calculate the value of C2.

$$2 \times 10\text{ kHz} < \frac{1}{2\pi \times R1 \times C2} \tag{7}$$

An R1 value of 10 k Ω and a C2 value less than 820 pF satisfy the requirement for a 10-kHz system bandwidth.

A selection of R1 = 10 k Ω and C2 = 680 pF would cause a low-pass filter with a corner frequency of 23.4 kHz.

8.2.1.3 Application Curves

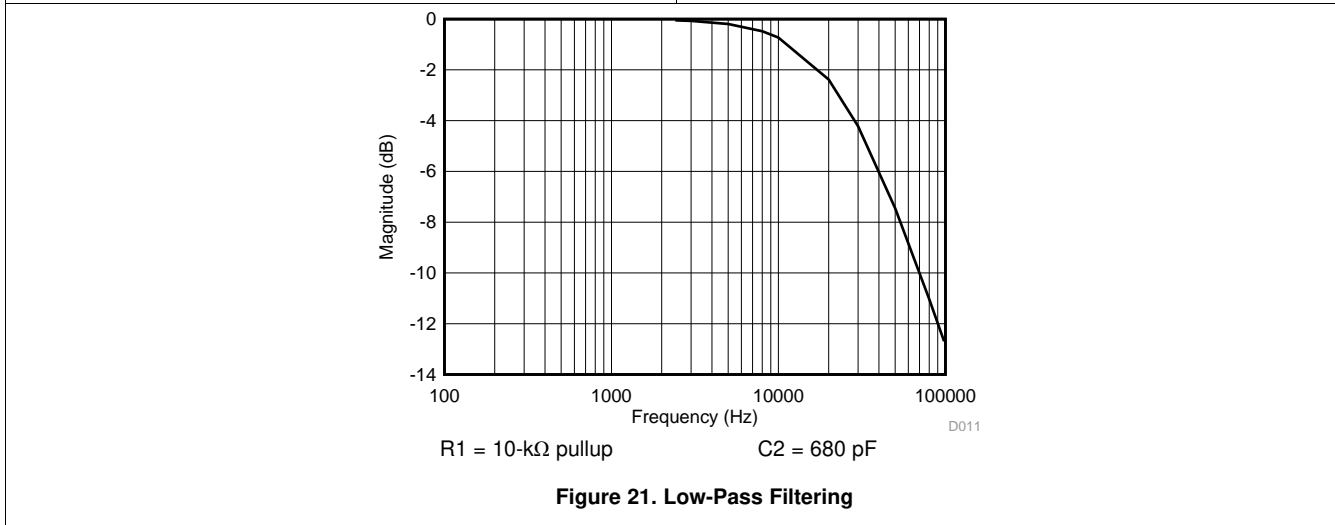
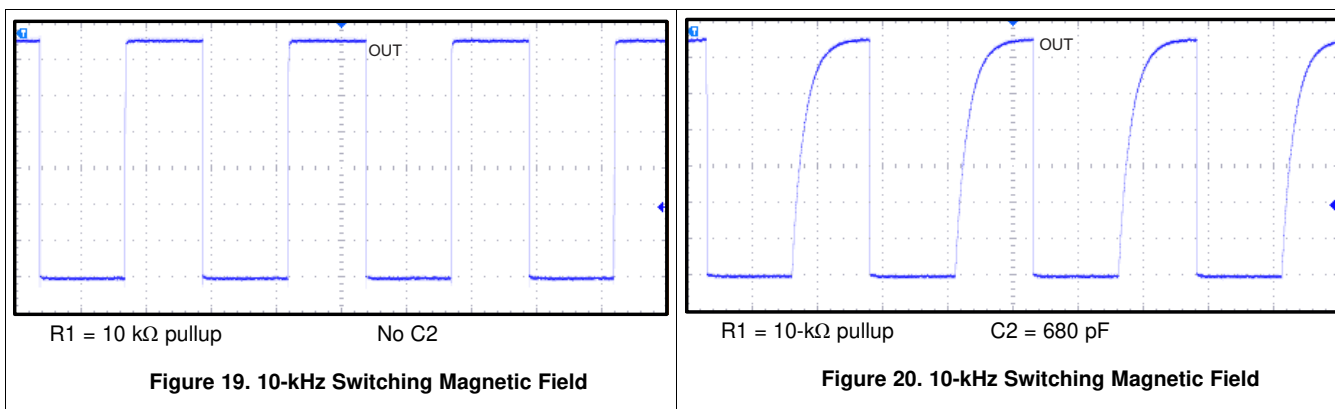

8.2.2 Alternative Two-Wire Application

For systems that require minimal wire count, the device output can be connected to V_{CC} through a resistor, and the total supplied current can be sensed near the controller.

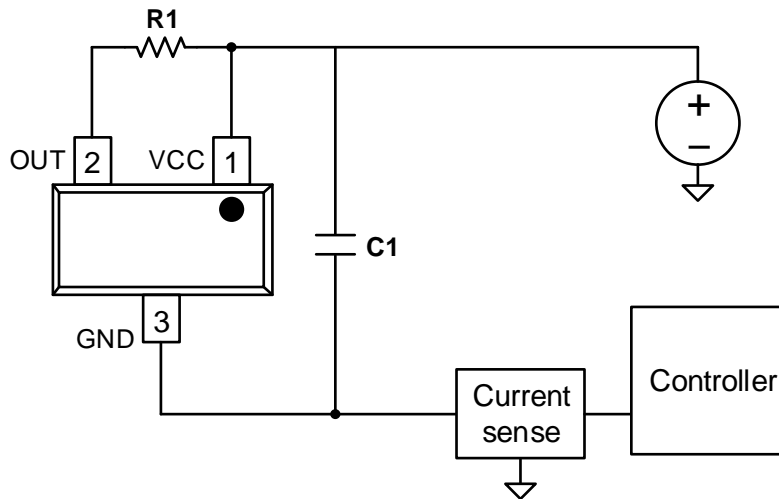

Figure 22. 2-Wire Application

Current can be sensed using a shunt resistor or other circuitry.

8.2.2.1 Design Requirements

Table 4 lists the related design parameters.

Table 4. Design Parameters

DESIGN PARAMETER	REFERENCE	EXAMPLE VALUE
Supply voltage	V_{CC}	12 V
OUT resistor	R1	1 k Ω
Bypass capacitor	C1	0.1 μ F
Current when $B < B_{RP}$	$I_{RELEASE}$	About 3 mA
Current when $B > B_{OP}$	$I_{OPERATE}$	About 15 mA

8.2.2.2 Detailed Design Procedure

When the open-drain output of the device is high-impedance, current through the path equals the I_{CC} of the device (approximately 3 mA).

When the output pulls low, a parallel current path is added, equal to $V_{CC} / (R1 + r_{DS(on)})$. Using 12 V and 1 k Ω , the parallel current is approximately 12 mA, making the total current approximately 15 mA.

The local bypass capacitor C1 should be at least 0.1 μ F, and a larger value if there is high inductance in the power line interconnect.

9 Power Supply Recommendations

The DRV5033 device is designed to operate from an input voltage supply (V_M) range between 2.5 and 38 V. A 0.01- μ F (minimum) ceramic capacitor rated for V_{CC} must be placed as close to the DRV5033 device as possible.

10 Layout

10.1 Layout Guidelines

The bypass capacitor should be placed near the DRV5033 device for efficient power delivery with minimal inductance. The external pullup resistor should be placed near the microcontroller input to provide the most stable voltage at the input; alternatively, an integrated pullup resistor within the GPIO of the microcontroller can be used.

Generally, using PCB copper planes underneath the DRV5033 device has no effect on magnetic flux, and does not interfere with device performance. This is because copper is not a ferromagnetic material. However, if nearby system components contain iron or nickel, they may redirect magnetic flux in unpredictable ways.

10.2 Layout Example

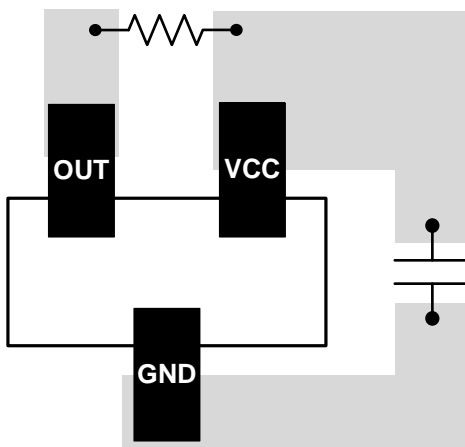

Figure 23. DRV5033 Layout Example

11 Device and Documentation Support

11.1 Device Support

11.1.1 Device Nomenclature

Figure 24 shows a legend for reading the complete device name for and DRV5033 device.

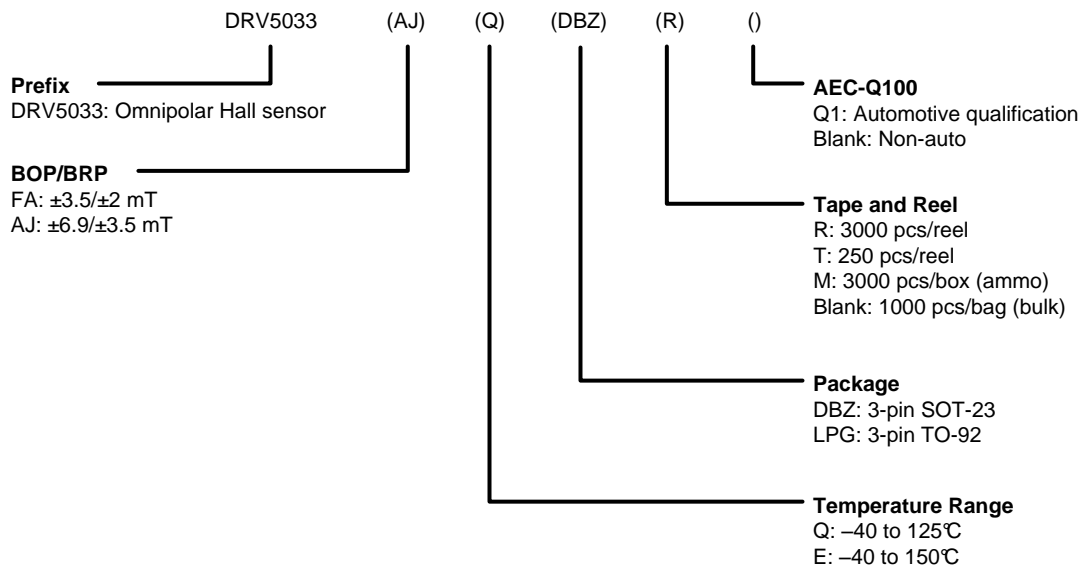

Figure 24. Device Nomenclature

11.1.2 Device Markings

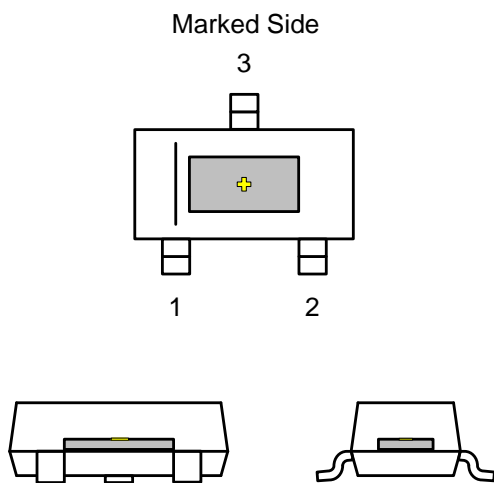

Figure 25. SOT-23 (DBZ) Package

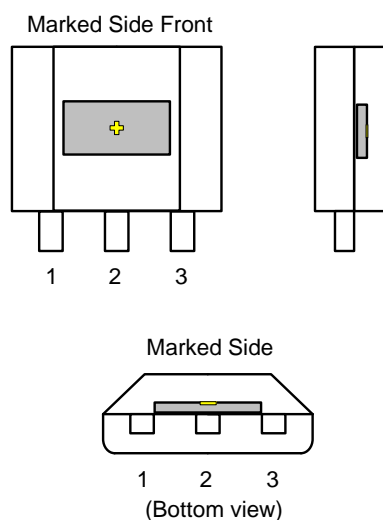

Figure 26. TO-92 (LPG) Package

⊕ indicates the Hall effect sensor (not to scale). The Hall element is located in the center of the package with a tolerance of $\pm 100 \mu\text{m}$. The height of the Hall element from the bottom of the package is $0.7 \text{ mm} \pm 50 \mu\text{m}$ in the DBZ package and $0.987 \text{ mm} \pm 50 \mu\text{m}$ in the LPG package.

11.2 Receiving Notification of Documentation Updates

To receive notification of documentation updates, navigate to the device product folder on ti.com. In the upper right corner, click on *Alert me* to register and receive a weekly digest of any product information that has changed. For change details, review the revision history included in any revised document.

11.3 Community Resources

The following links connect to TI community resources. Linked contents are provided "AS IS" by the respective contributors. They do not constitute TI specifications and do not necessarily reflect TI's views; see TI's [Terms of Use](#).

TI E2E™ Online Community *TI's Engineer-to-Engineer (E2E) Community*. Created to foster collaboration among engineers. At e2e.ti.com, you can ask questions, share knowledge, explore ideas and help solve problems with fellow engineers.

Design Support *TI's Design Support* Quickly find helpful E2E forums along with design support tools and contact information for technical support.

11.4 Trademarks

E2E is a trademark of Texas Instruments.
All other trademarks are the property of their respective owners.

11.5 Electrostatic Discharge Caution



These devices have limited built-in ESD protection. The leads should be shorted together or the device placed in conductive foam during storage or handling to prevent electrostatic damage to the MOS gates.

11.6 Glossary

[SLYZ022](#) — *TI Glossary*.

This glossary lists and explains terms, acronyms, and definitions.

12 Mechanical, Packaging, and Orderable Information

The following pages include mechanical, packaging, and orderable information. This information is the most current data available for the designated devices. This data is subject to change without notice and revision of this document. For browser-based versions of this data sheet, refer to the left-hand navigation.

PACKAGING INFORMATION

Orderable Device	Status (1)	Package Type	Package Drawing	Pins	Package Qty	Eco Plan (2)	Lead finish/ Ball material (6)	MSL Peak Temp (3)	Op Temp (°C)	Device Marking (4/5)	Samples
DRV5033AJQDBZR	ACTIVE	SOT-23	DBZ	3	3000	RoHS & Green	NIPDAUAG SN	Level-1-260C-UNLIM	-40 to 125	(+QLAJ, 1J72)	Samples
DRV5033AJQDBZT	ACTIVE	SOT-23	DBZ	3	250	RoHS & Green	NIPDAUAG SN	Level-1-260C-UNLIM	-40 to 125	(+QLAJ, 1J72)	Samples
DRV5033AJQLPG	ACTIVE	TO-92	LPG	3	1000	RoHS & Green	SN	N / A for Pkg Type	-40 to 125	+QLAJ	Samples
DRV5033AJQLPGM	ACTIVE	TO-92	LPG	3	3000	RoHS & Green	SN	N / A for Pkg Type	-40 to 125	+QLAJ	Samples
DRV5033FAQDBZR	ACTIVE	SOT-23	DBZ	3	3000	RoHS & Green	SN	Level-1-260C-UNLIM	-40 to 125	(+QLFA, 1J8W)	Samples

(1) The marketing status values are defined as follows:

ACTIVE: Product device recommended for new designs.

LIFEBUY: TI has announced that the device will be discontinued, and a lifetime-buy period is in effect.

NRND: Not recommended for new designs. Device is in production to support existing customers, but TI does not recommend using this part in a new design.

PREVIEW: Device has been announced but is not in production. Samples may or may not be available.

OBSELETE: TI has discontinued the production of the device.

(2) **RoHS:** TI defines "RoHS" to mean semiconductor products that are compliant with the current EU RoHS requirements for all 10 RoHS substances, including the requirement that RoHS substance do not exceed 0.1% by weight in homogeneous materials. Where designed to be soldered at high temperatures, "RoHS" products are suitable for use in specified lead-free processes. TI may reference these types of products as "Pb-Free".

RoHS Exempt: TI defines "RoHS Exempt" to mean products that contain lead but are compliant with EU RoHS pursuant to a specific EU RoHS exemption.

Green: TI defines "Green" to mean the content of Chlorine (Cl) and Bromine (Br) based flame retardants meet JS709B low halogen requirements of <=1000ppm threshold. Antimony trioxide based flame retardants must also meet the <=1000ppm threshold requirement.

(3) MSL, Peak Temp. - The Moisture Sensitivity Level rating according to the JEDEC industry standard classifications, and peak solder temperature.

(4) There may be additional marking, which relates to the logo, the lot trace code information, or the environmental category on the device.

(5) Multiple Device Markings will be inside parentheses. Only one Device Marking contained in parentheses and separated by a "~" will appear on a device. If a line is indented then it is a continuation of the previous line and the two combined represent the entire Device Marking for that device.

(6) Lead finish/Ball material - Orderable Devices may have multiple material finish options. Finish options are separated by a vertical ruled line. Lead finish/Ball material values may wrap to two lines if the finish value exceeds the maximum column width.

Important Information and Disclaimer: The information provided on this page represents TI's knowledge and belief as of the date that it is provided. TI bases its knowledge and belief on information provided by third parties, and makes no representation or warranty as to the accuracy of such information. Efforts are underway to better integrate information from third parties. TI has taken and continues to take reasonable steps to provide representative and accurate information but may not have conducted destructive testing or chemical analysis on incoming materials and chemicals. TI and TI suppliers consider certain information to be proprietary, and thus CAS numbers and other limited information may not be available for release.

In no event shall TI's liability arising out of such information exceed the total purchase price of the TI part(s) at issue in this document sold by TI to Customer on an annual basis.

OTHER QUALIFIED VERSIONS OF DRV5033 :

- Automotive: [DRV5033-Q1](#)

NOTE: Qualified Version Definitions:

- Automotive - Q100 devices qualified for high-reliability automotive applications targeting zero defects

TAPE AND REEL INFORMATION

QUADRANT ASSIGNMENTS FOR PIN 1 ORIENTATION IN TAPE

*All dimensions are nominal

Device	Package Type	Package Drawing	Pins	SPQ	Reel Diameter (mm)	Reel Width W1 (mm)	A0 (mm)	B0 (mm)	K0 (mm)	P1 (mm)	W (mm)	Pin1 Quadrant
DRV5033AJQDBZR	SOT-23	DBZ	3	3000	180.0	8.4	3.15	2.77	1.22	4.0	8.0	Q3
DRV5033AJQDBZR	SOT-23	DBZ	3	3000	178.0	9.0	3.15	2.77	1.22	4.0	8.0	Q3
DRV5033AJQDBZT	SOT-23	DBZ	3	250	178.0	9.0	3.15	2.77	1.22	4.0	8.0	Q3
DRV5033AJQDBZT	SOT-23	DBZ	3	250	180.0	8.4	3.15	2.77	1.22	4.0	8.0	Q3
DRV5033FAQDBZR	SOT-23	DBZ	3	3000	178.0	9.0	3.15	2.77	1.22	4.0	8.0	Q3
DRV5033FAQDBZR	SOT-23	DBZ	3	3000	180.0	8.4	3.15	2.77	1.22	4.0	8.0	Q3

TAPE AND REEL BOX DIMENSIONS



*All dimensions are nominal

Device	Package Type	Package Drawing	Pins	SPQ	Length (mm)	Width (mm)	Height (mm)
DRV5033AJQDBZR	SOT-23	DBZ	3	3000	202.0	201.0	28.0
DRV5033AJQDBZR	SOT-23	DBZ	3	3000	180.0	180.0	18.0
DRV5033AJQDBZT	SOT-23	DBZ	3	250	180.0	180.0	18.0
DRV5033AJQDBZT	SOT-23	DBZ	3	250	202.0	201.0	28.0
DRV5033FAQDBZR	SOT-23	DBZ	3	3000	180.0	180.0	18.0
DRV5033FAQDBZR	SOT-23	DBZ	3	3000	202.0	201.0	28.0

LPG0003A



PACKAGE OUTLINE

TO-92 - 5.05 mm max height

TRANSISTOR OUTLINE

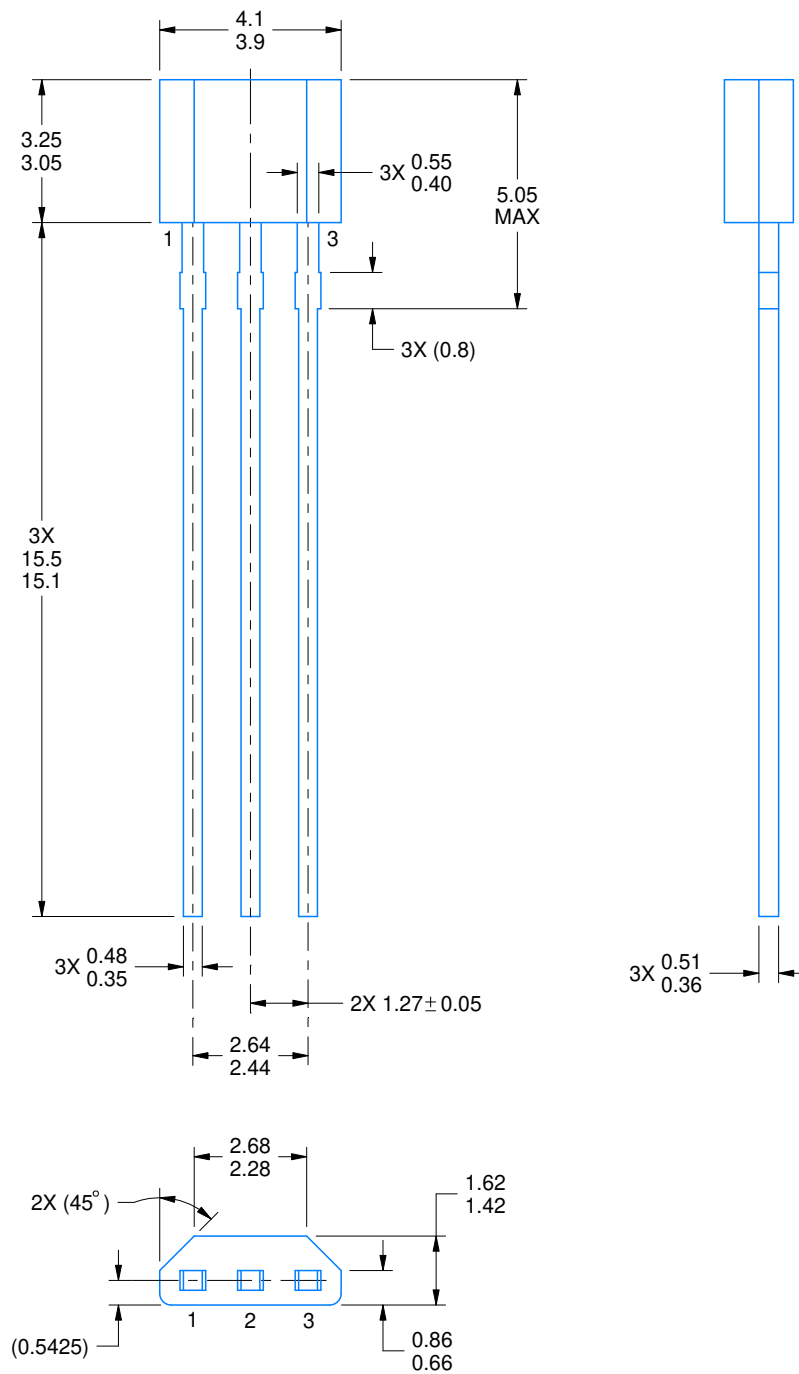

4221343/C 01/2018

NOTES:

1. All linear dimensions are in millimeters. Any dimensions in parenthesis are for reference only. Dimensioning and tolerancing per ASME Y14.5M.
2. This drawing is subject to change without notice.

EXAMPLE BOARD LAYOUT

LPG0003A

TO-92 - 5.05 mm max height

TRANSISTOR OUTLINE

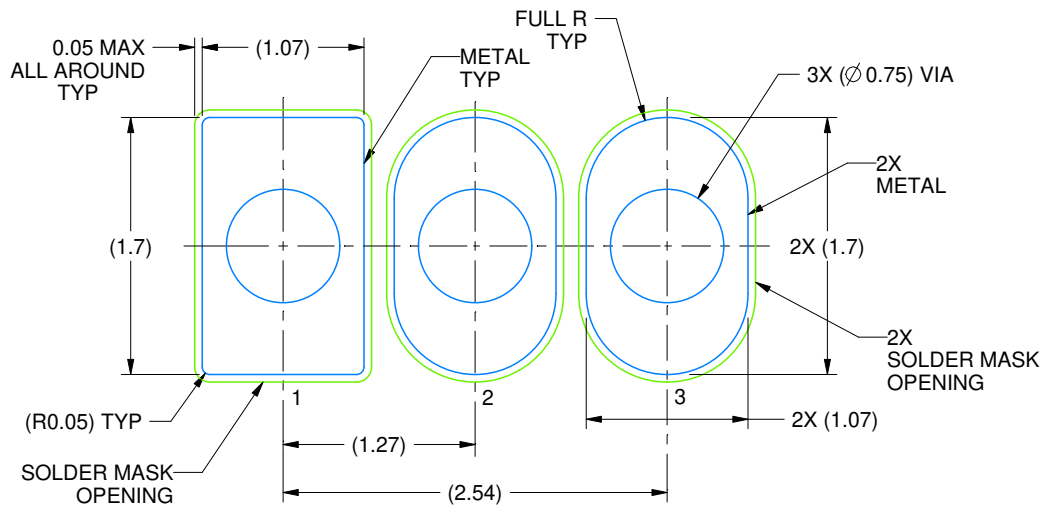

LAND PATTERN EXAMPLE
NON-SOLDER MASK DEFINED
SCALE:20X

4221343/C 01/2018

TAPE SPECIFICATIONS

LPG0003A

TO-92 - 5.05 mm max height

TRANSISTOR OUTLINE

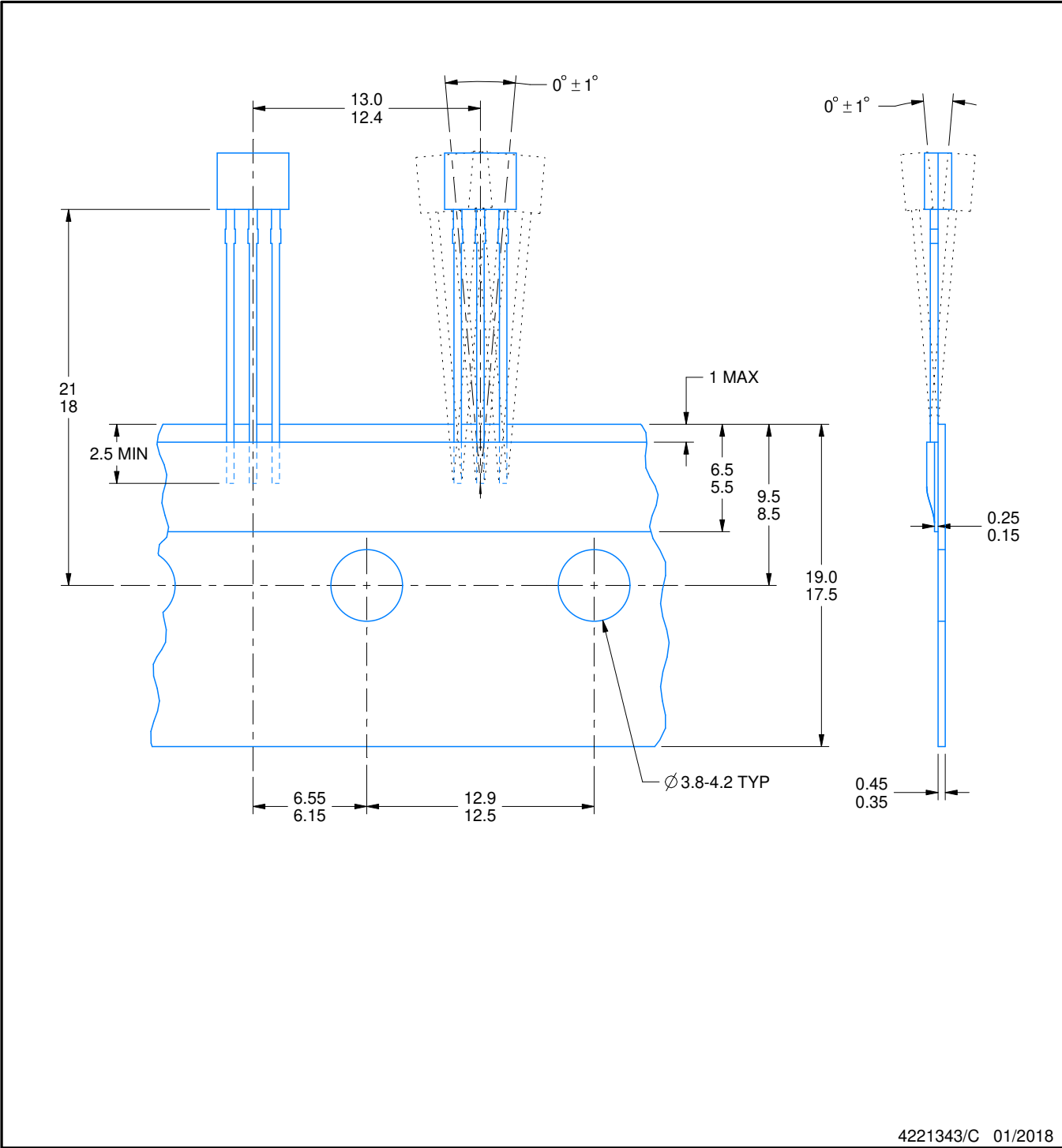

DBZ0003A



PACKAGE OUTLINE

SOT-23 - 1.12 mm max height

SMALL OUTLINE TRANSISTOR

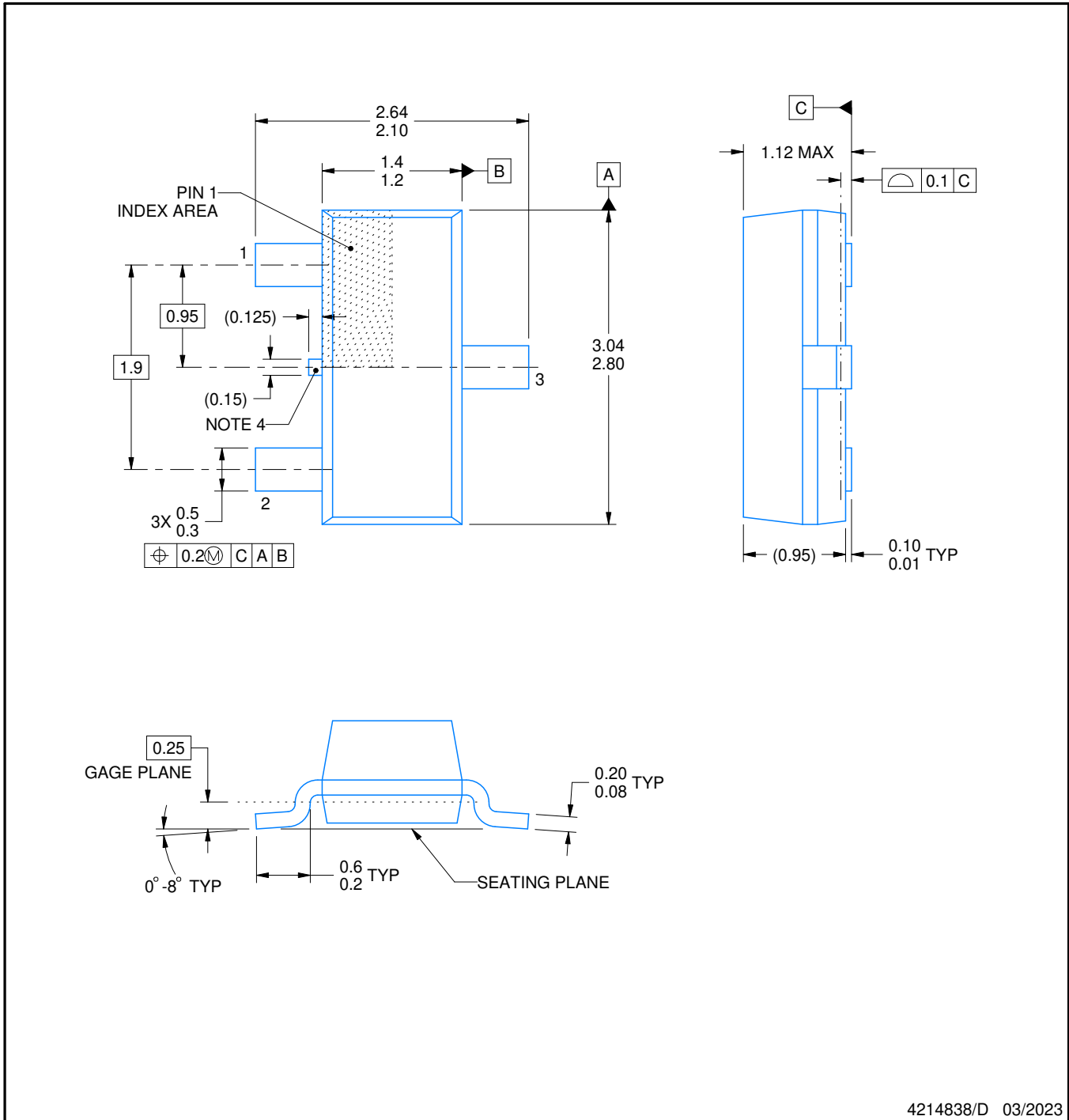

4214838/D 03/2023

NOTES:

1. All linear dimensions are in millimeters. Any dimensions in parenthesis are for reference only. Dimensioning and tolerancing per ASME Y14.5M.
2. This drawing is subject to change without notice.
3. Reference JEDEC registration TO-236, except minimum foot length.
4. Support pin may differ or may not be present.

EXAMPLE BOARD LAYOUT

DBZ0003A

SOT-23 - 1.12 mm max height

SMALL OUTLINE TRANSISTOR

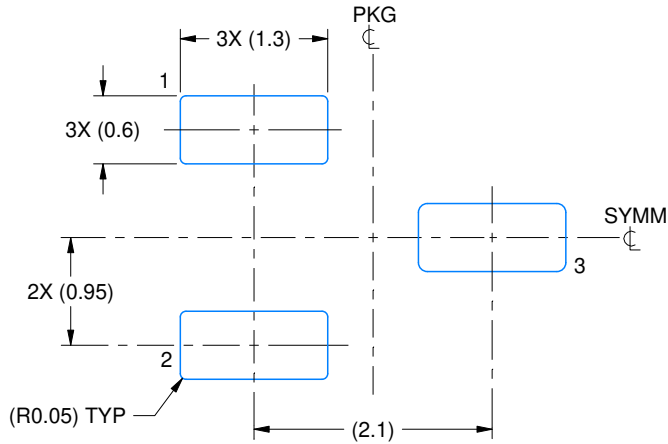

LAND PATTERN EXAMPLE
SCALE:15X

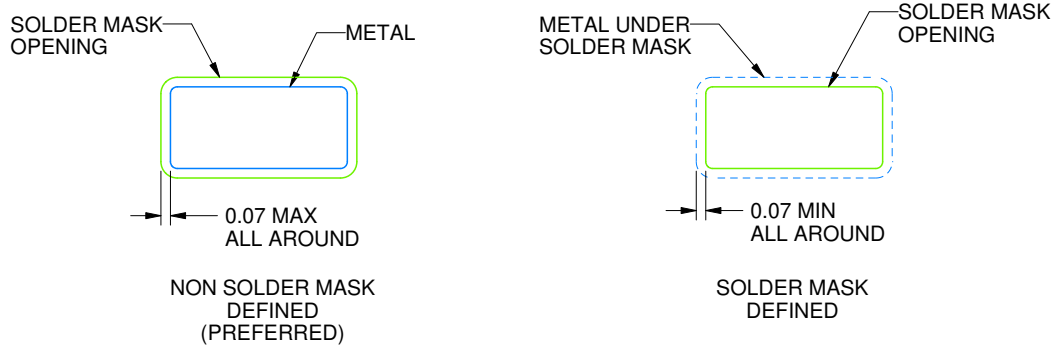

SOLDER MASK DETAILS

4214838/D 03/2023

NOTES: (continued)

- 4. Publication IPC-7351 may have alternate designs.
- 5. Solder mask tolerances between and around signal pads can vary based on board fabrication site.

EXAMPLE STENCIL DESIGN

DBZ0003A

SOT-23 - 1.12 mm max height

SMALL OUTLINE TRANSISTOR

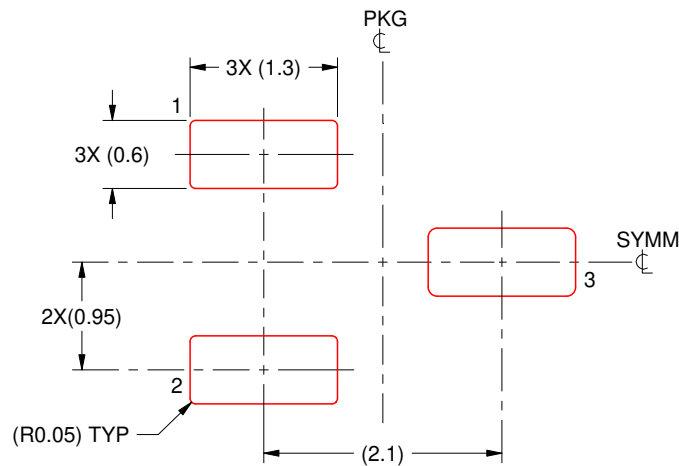

SOLDER PASTE EXAMPLE
BASED ON 0.125 THICK STENCIL
SCALE:15X

4214838/D 03/2023

NOTES: (continued)

6. Laser cutting apertures with trapezoidal walls and rounded corners may offer better paste release. IPC-7525 may have alternate design recommendations.
7. Board assembly site may have different recommendations for stencil design.

IMPORTANT NOTICE AND DISCLAIMER

TI PROVIDES TECHNICAL AND RELIABILITY DATA (INCLUDING DATA SHEETS), DESIGN RESOURCES (INCLUDING REFERENCE DESIGNS), APPLICATION OR OTHER DESIGN ADVICE, WEB TOOLS, SAFETY INFORMATION, AND OTHER RESOURCES "AS IS" AND WITH ALL FAULTS, AND DISCLAIMS ALL WARRANTIES, EXPRESS AND IMPLIED, INCLUDING WITHOUT LIMITATION ANY IMPLIED WARRANTIES OF MERCHANTABILITY, FITNESS FOR A PARTICULAR PURPOSE OR NON-INFRINGEMENT OF THIRD PARTY INTELLECTUAL PROPERTY RIGHTS.

These resources are intended for skilled developers designing with TI products. You are solely responsible for (1) selecting the appropriate TI products for your application, (2) designing, validating and testing your application, and (3) ensuring your application meets applicable standards, and any other safety, security, regulatory or other requirements.

These resources are subject to change without notice. TI grants you permission to use these resources only for development of an application that uses the TI products described in the resource. Other reproduction and display of these resources is prohibited. No license is granted to any other TI intellectual property right or to any third party intellectual property right. TI disclaims responsibility for, and you will fully indemnify TI and its representatives against, any claims, damages, costs, losses, and liabilities arising out of your use of these resources.

TI's products are provided subject to [TI's Terms of Sale](#) or other applicable terms available either on [ti.com](https://www.ti.com) or provided in conjunction with such TI products. TI's provision of these resources does not expand or otherwise alter TI's applicable warranties or warranty disclaimers for TI products.

TI objects to and rejects any additional or different terms you may have proposed.

Mailing Address: Texas Instruments, Post Office Box 655303, Dallas, Texas 75265
Copyright © 2023, Texas Instruments Incorporated