

## TCFS-\*\*-\*\*\*-1\*\*-100CH

See over for Part Numbering System

CONDUCTIVE HOT-MELT ADHESIVE

a) Part as supplied.

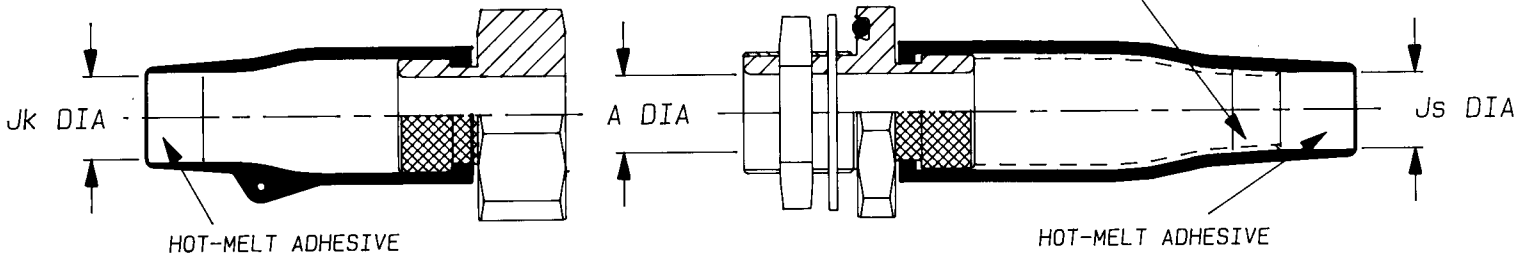

b) Part after unrestricted recovery.

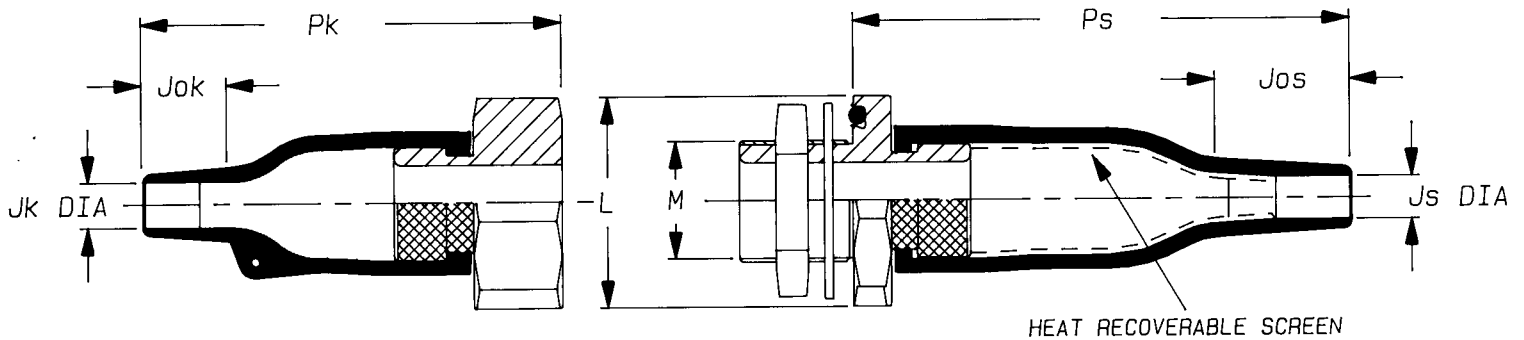

KITS TO INCLUDE CLEANING TISSUE, 1 PIECE 100 GRIT EMERY CLOTH & 1 PIECE OF ATUM.  
KIT TO BE USED IN CONJUNCTION WITH TCFS INSTALLATION PROCEDURE.

Dimensions (in millimetres)

PART No.	A		Jk		Js		M THREAD	A/F Nut	L NOM	Pk ±10%	Ps ±10%	Jok Ref	Jos Ref
	min	max	min	max	min	max							
TCFS-12	7.4	11	5.7	7	5.0	5.0	M12 x 1.5	17	24	49	50	9	15
TCFS-16	10.1	15	6.0	9	6.0	6.0	M16 x 1.5	22	29	56	65	12	17
TCFS-20	14.1	19	7.2	11	7.2	7.2	M20 x 1.5	27	34	60	77	17	20
TCFS-24	19.1	23	8.5	17	8.5	8.5	M24 x 1.5	30	38	73	90	20	25
TCFS-30	24.1	29	10.0	21	10.0	10.0	M30 x 1.5	36	47	72	115	21	30
TCFS-36	30.1	35	15.8	29	15.8	15.8	M36 x 1.5	41	52	103	140	39	30

Copyright (!)  
Urheberrechte

The copyright in this drawing is the property of Raychem Ltd. The drawing is issued on condition that it is not copied, reproduced or disclosed to a third party, either in whole or in part without the prior written consent of Raychem Ltd.

Drawn D.MURRAY Checked *SM* Issue 5 Date May 1996

Conforms to ISO Recommendations  
3rd Angle Projection  
Not to Scale

Approval  
Design

*AAPS.*

MKTG.

*M*

Q.A.

*[Signature]*

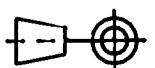

Iss.	Date	E.C.R. No.	Details of Change
2	October 1991	H0044	L was %
3	November 1991	H0044	Pk WAS 39 ON S/S 12
4	November 1992	H0125	S/S 30 L WAS 48
5	May 1996	H0295	S/S Pk WAS 37

Material

(-100) ZERO HALOGEN

Part Numbering System.

TCFS-\*\*-\*\*\*-1\*\*-100CH

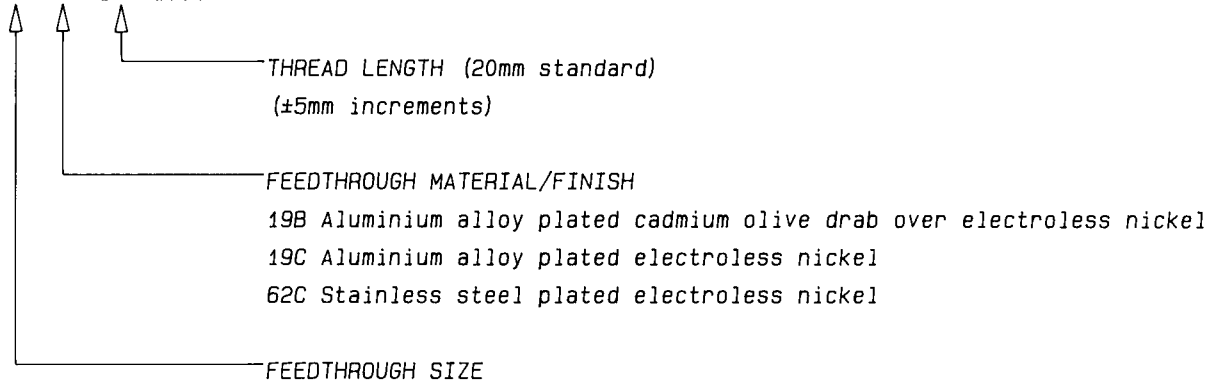

Raychem  
 Thermofit Division, Europe,  
 Swindon, Wiltshire, England.  
 Telephone: (0793) 528171 Fax: 573923