

# VSC3304

## 8.5 Gbps 4 × 4 Crosspoint Switch

The VSC3304 is a 4-port 8.5 Gbps asynchronous switch with advanced signal equalization designed for high-speed serial backplanes and cable interconnect applications. VSC3304 switches allow multicast, loopback, and reconfigurable Input/Output (I/O) capability, allowing for great flexibility in allocating and routing signals in a broad range of applications. The VSC3304 includes dual time-constant equalization, which significantly reduces jitter associated with driving multigigabit signals across backplanes and cables.

Using a fully asynchronous architecture allows any data rate or protocol on any channel without the need for an external reference clock. This gives the VSC3304 wire-like interoperability in virtually any application that uses binary signaling. The VSC3304 can also be used as a buffer that simplifies and enhances the design of high-speed signal paths by providing signal equalization at both inputs and outputs to reduce or reverse signal degradation due to transmission line effects.

VSC3304 ports may be configured as either inputs or outputs without restriction. This design provides the flexibility of using the device as a standard 4 × 4 crosspoint, or any ratio from 1 × 7 to 7 × 1. This unique feature allows full I/O utilization in any application that translates to a significant reduction in chip count. Featuring programmable input signal equalization and output pre-emphasis, each with multiple time constants, the VSC3304 is also ideal for countering signal degradation over a wide variety of transmission media types and lengths.

Typical power consumption for the device is 160 mW per active channel, and unused channels may be de-activated to save the power associated with those ports. The output drivers for the VSC3304 also feature a wide supply voltage range, from 1.8 V to 3.3 V, that allows flexibility in matching the output swing to the application requirements.

The VSC3304 has a loss of signal (LOS) detector with programmable thresholds on every input port. LOS forwarding can be enabled for each of the outputs, which will cause the outputs to be squelched in response to a LOS detect at the corresponding input, thereby propagating signal envelopes through the switch. VSC3304 programming is through a standard two-wire serial interface. The interface address can be hardwired through static pins or through a proprietary two-pin interface that allows for address assignment after power-up.

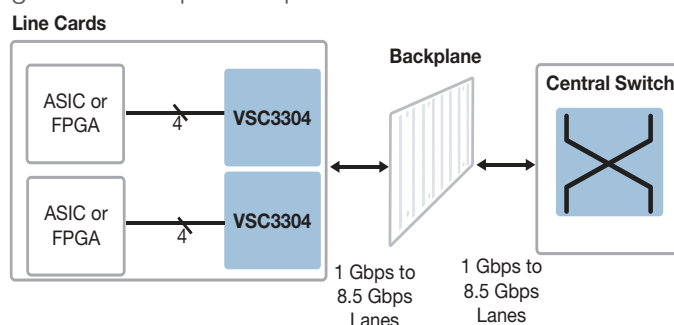

### Applications

- Wideband signal switching and clean-up
- Line driver or receiver
- Backplane signal fanout, driver, or receiver
- Copper cable driver or receiver
- PCB signal enhancement
- High-speed signal conditioner

### Specifications

- 8.5 Gbps non-return-to-zero (NRZ) per-channel data rate
- 2.5 V core; 1.8 V, 2.5 V, and 3.3 V high-speed I/O
- 1.2 W at 3.3 V, or 0.9 W at 2.5 V, or 0.7 W at 1.8 V

Microsemi makes no warranty, representation, or guarantee regarding the information contained herein or the suitability of its products and services for any particular purpose, nor does Microsemi assume any liability whatsoever arising out of the application or use of any product or circuit. The products sold hereunder and any other products sold by Microsemi have been subject to limited testing and should not be used in conjunction with mission-critical equipment or applications. Any performance specifications are believed to be reliable but are not verified, and Buyer must conduct and complete all performance and other testing of the products, alone and together with, or installed in, any end-products. Buyer shall not rely on any data and performance specifications or parameters provided by Microsemi. It is the Buyer's responsibility to independently determine suitability of any products and to test and verify the same. The information provided by Microsemi hereunder is provided "as is, where is" and with all faults, and the entire risk associated with such information is entirely with the Buyer. Microsemi does not grant, explicitly or implicitly, to any party any patent rights, licenses, or any other IP rights, whether with regard to such information itself or anything described by such information. Information provided in this document is proprietary to Microsemi, and Microsemi reserves the right to make any changes to the information in this document or to any products and services at any time without notice.

# VSC3304

## 8.5 Gbps 4 × 4 Crosspoint Switch

### Features

- 8.5 Gbps non-return-to-zero (NRZ) data bandwidth
- Fully non-blocking and multicasting switch core with per-pin signal inversion capability
- Multiple time-constant programmable input and output equalization
- Wide equalization adjustment range
- Fully asynchronous operation with <1 ns latency
- Reconfigurable Input/Output (I/O) capability
- LOS detection and forwarding
- Small 7 mm × 7 mm BGA with 1.0 mm pin pitch

### Benefits

- Transparent support for virtually all data rates and protocols
- Allows complete flexibility in routing and distributing signals
- Compensates for multiple impairments in a signal path
- Supports all types of interconnect media: PCB, backplanes, and cable
- No adjustments based on data rate or reference clock required
- Customize the I/O to the application
- OOB forwarding for protocols like SAS and SATA
- Convenient size and pin spacing for signal routing flexibility

### Related Products

Visit [www.microsemi.com](http://www.microsemi.com) for information about other related products.

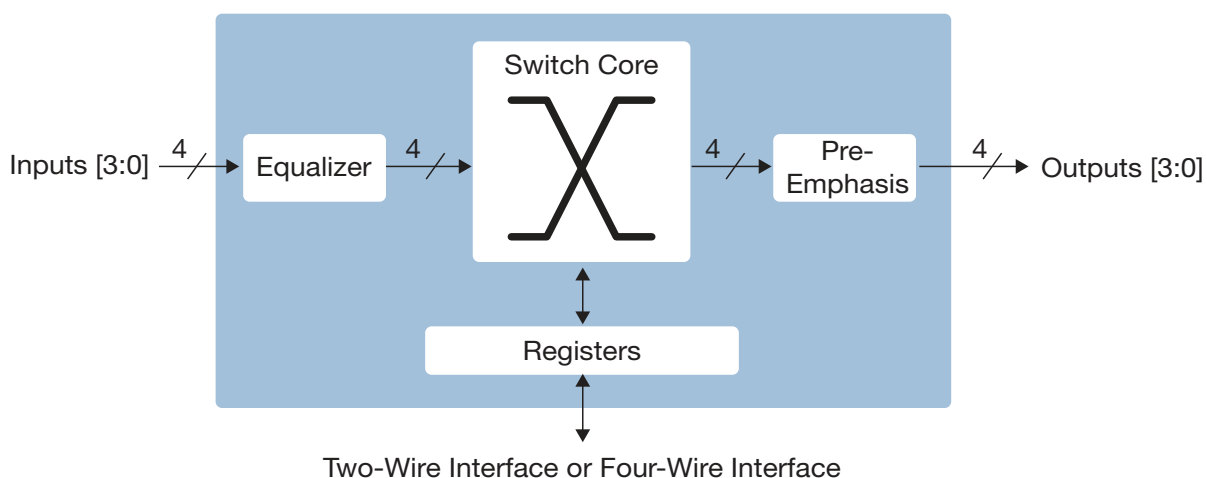

**Microsemi Corporate Headquarters**  
 One Enterprise, Aliso Viejo, CA 92656 USA  
 Within the USA: +1 (800) 713-4113  
 Outside the USA: +1 (949) 380-6100  
 Sales: +1 (949) 380-6136  
 Fax: +1 (949) 215-4996  
 email: [sales.support@microsemi.com](mailto:sales.support@microsemi.com)  
[www.microsemi.com](http://www.microsemi.com)

Microsemi Corporation (Nasdaq: MSCC) offers a comprehensive portfolio of semiconductor and system solutions for communications, defense and security, aerospace, and industrial markets. Products include high-performance and radiation-hardened analog mixed-signal integrated circuits, FPGAs, SoCs, and ASICs; power management products; timing and synchronization devices and precise time solutions; voice processing devices; RF solutions; discrete components; enterprise storage and communications solutions, security technologies, and scalable anti-tamper products; Ethernet solutions; Power-over-Ethernet ICs and midspans; custom design capabilities and services. Microsemi is headquartered in Aliso Viejo, California, and has approximately 4,800 employees worldwide. Learn more at [www.microsemi.com](http://www.microsemi.com).