

Order No.: 1145402

Type: DMC 0,5/ 4-G1SHL-2,54P20THRR24

PCB headers, Reflow/wave soldering



The figure shows a 2-pos. version with 4 contacts

1 Main features



- | | | | |
|-------------------------|----------------------|------------------------|-----------------|
| • No. of pos. | 4 | • Nominal current | 6 A |
| • Nominal cross section | 0.34 mm ² | • Nominal voltage | 160 V |
| • Color | black (9005) | • Connection direction | |
| • Pitch | 2.54 mm | • Type of packaging | 24 mm wide tape |
| • Mounting type | | | |

2 Your advantages

- ✓ Gold-plated contacts ensure transfer quality remains stable over the long term
- ✓ Designed for integration into the SMT process
- ✓ Conductor connection on several levels enables higher contact density with the same surface area
- ✓ Supplied in tape-on-reel packing according to IEC 60286-3 for automated mounting



Make sure you always use the latest documentation.
It can be downloaded at: phoenixcontact.net/product/1145402

1145402 DMC 0,5/ 4-G1SHL-2,54P20THRR24**3 Table of contents**

1	Main features.....	1
2	Your advantages	1
3	Table of contents	2
4	3D model in PDF can be activated (Acrobat Reader only).....	3
5	General Technical Data	4
	5.1 Item properties	4
	5.2 Mounting	4
6	Material properties.....	4
	6.1 Material of metal parts.....	4
7	Dimensions.....	5
	7.1 Dimensions for the product	5
8	Series drawing.....	6
9	Application.....	7
10	Packaging information	7
11	Blister drawing	8
	11.1 Processing notes	9
	11.2 Temperature limit values	9
12	Mechanical tests.....	10
	12.1 Visual examination	10
	12.2 Dimensional test.....	10
	12.3 Resistance of marking	10
	12.4 Polarization and coding	10
	12.5 Contact retention in insert	10
13	Insertion and withdrawal forces	11
14	Electrical tests	12
	14.1 Electrical data	12
	14.2 Air and creepage distances	12
15	Current carrying capacity/derating curves	13
	15.1 Vibration test	13
16	Approvals / Certificates.....	14
17	Commercial Data.....	15
18	Combination tests.....	16

1145402 DMC 0,5/ 4-G1SHL-2,54P20THRR24

4 3D model in PDF can be activated (Acrobat Reader only)



1145402 DMC 0,5/ 4-G1SHL-2,54P20THRR24**5 General Technical Data****5.1 item properties**

Order No.	1145402
Type	DMC 0,5/ 4-G1SHL-2,54P20THRR24
Plug-in system	MICRO COMBICON - DFMC 0,5 lock & shielded
Product type	PCB headers
Range of articles	DMC 0,5/..-G1SHL-THR
Pitch	
Range of positions	...
Number of positions	4

5.2 Mounting

Type of locking	shielded connection
	Lock & Shield

6 Material properties**6.1 Material of metal parts**

Note	WEEE/RoHS-compliant, whisker-free acc. to IEC 60068-2-82/JEDEC JESD 201
Contact material	Cu alloy
Surface contact area	Nickel (2 - 4 µm Ni) , Gold (0.25 Au)
Soldering area surface	Nickel (2 - 4 µm Ni) , Gold (0.25 Au)
Surface characteristics	Completely gold-plated
Insulating material data	Housing
Insulating material	LCP
Insulating material group	IIIa
CTI according to IEC 60112	175
Flammability rating according to UL 94	V0
Color	black (9005)

1145402 DMC 0,5/ 4-G1SHL-2,54P20THRR24**7 Dimensions****7.1 Dimensions for the product**

Length	14.35 mm
Width	14.47 mm
Height (without solder pin)	8.29 mm
Total height	10.29 mm
Solder pin [P]	2 mm
Dimension a	7.62 mm

1145402 DMC 0,5/ 4-G1SHL-2,54P20THRR24

8 Series drawing

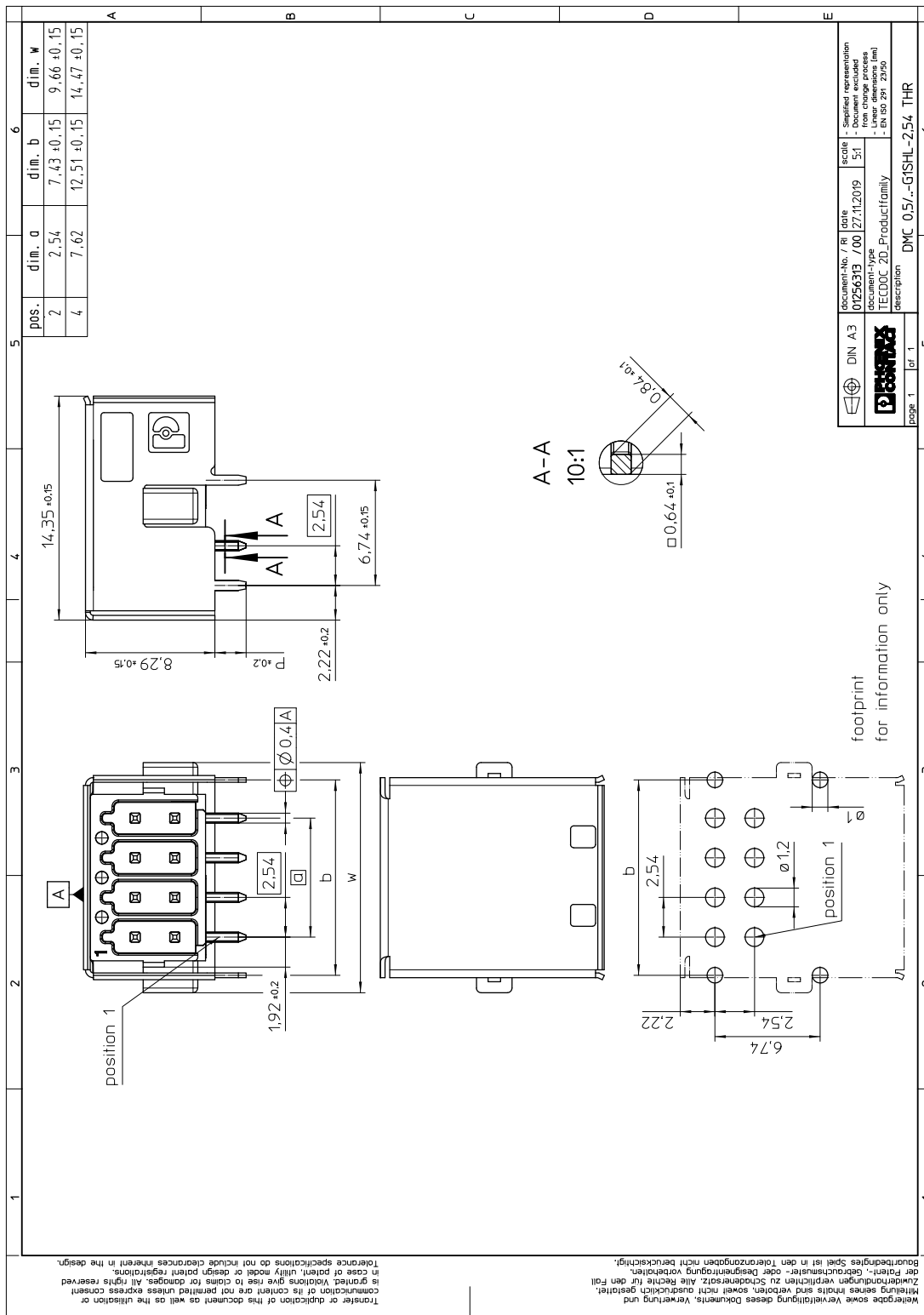

1145402 DMC 0,5/ 4-G1SHL-2,54P20THRR24**9 Application****10 Packaging information**

Type of packaging	24 mm wide tape
Pieces per package	300
Outer packaging type	Transparent-Bag
ESD level	(D) electrostatically conductive
Specification	DIN EN 61340-5-1 (VDE 0300-5-1): 2008-07
[W] tape width	24 mm
[A] coil diameter	330 mm
[W2] coil overall dimension	30.4 mm
Number of products per coil	300

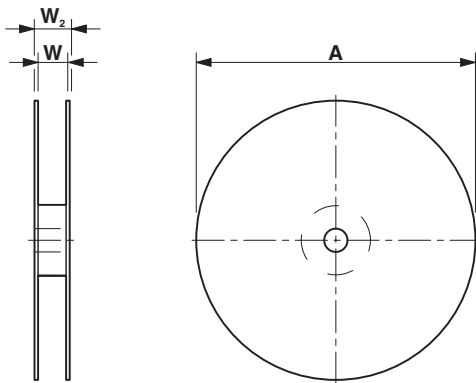

1145402 DMC 0,5/ 4-G1SHL-2,54P20THRR24

11 Blister drawing

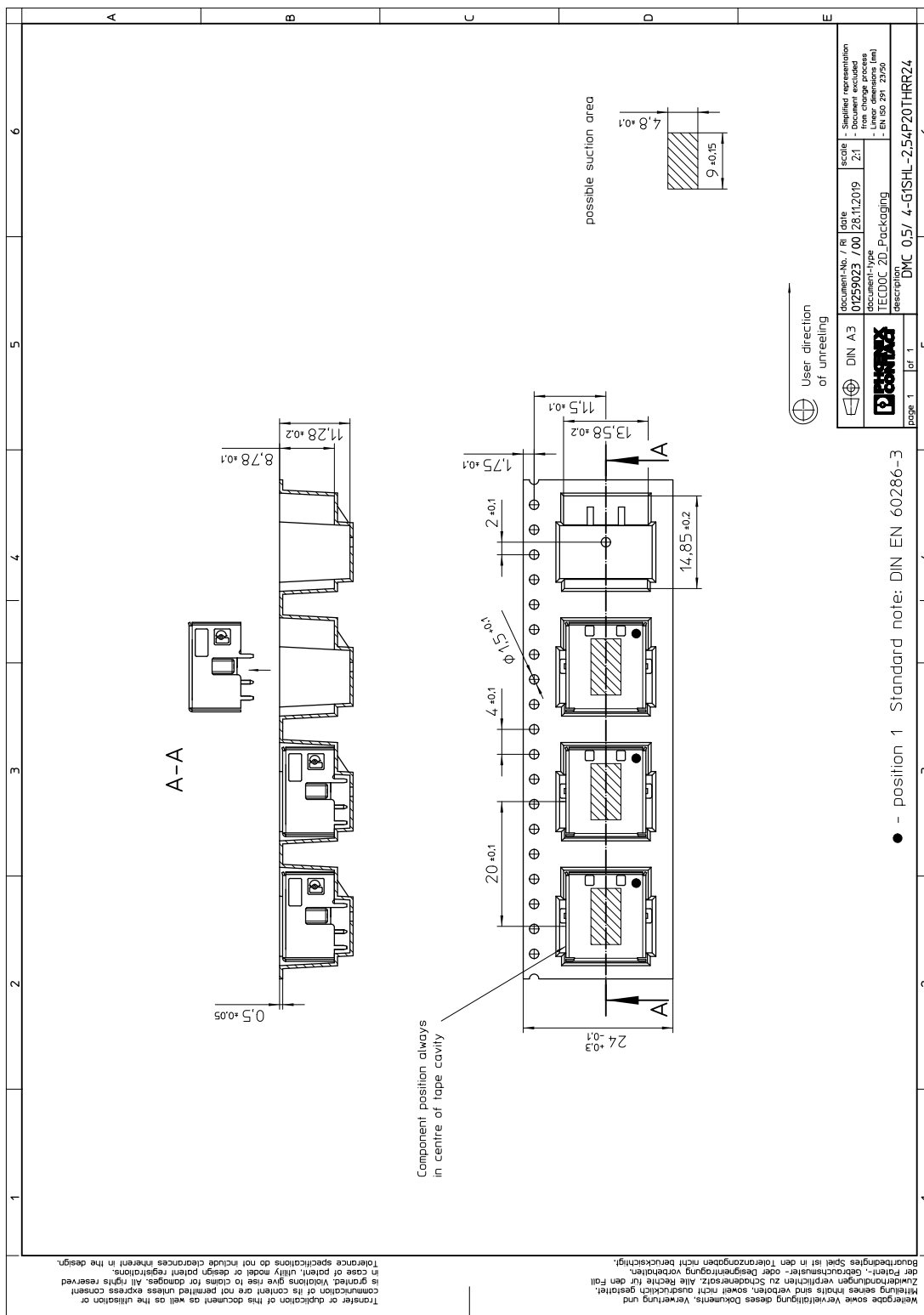

1145402 DMC 0,5/ 4-G1SHL-2,54P20THRR24**11.1 Processing notes**

Process	Reflow/wave soldering
Specification	Following IPC/JEDEC J-STD-020E:2014-12
Specification	Following IEC 61760-1:2006-04
Specification	Following IEC 60068-2-58:2015-03
Moisture Sensitive Level	MSL 1
Classification temperature T_c	max. 260 °C
Solder cycles in the reflow	3
swash circumference	see dimensional drawing

11.2 Temperature limit values

Ambient temperature (storage/transport)	-20 °C ... 70 °C
Ambient temperature (assembly)	-5 °C ... 80 °C
Ambient temperature (installation)	-40 °C ... 80 °C (dependent on the derating curve)
Ambient temperature (mobile installation)	-20 °C 80 °C dependent on the derating curve

1145402 DMC 0,5/ 4-G1SHL-2,54P20THRR24**12 Mechanical tests****12.1 Visual examination**

Specification	IEC 61984:2008-10
Visual examination	Test passed
Specification	IEC 60512-1-1:2002-02

12.2 Dimensional test

Dimensional test	Test passed
Specification	IEC 60512-1-2:2002-02

12.3 Resistance of marking

Resistance of marking	Test passed
Specification	IEC 60068-2-70:1995-12

12.4 Polarization and coding

Polarization and coding	Test passed
Specification	IEC 60512-13-5:2006-02
Test force	20 N

12.5 Contact retention in insert

Contact retention in insert	Test passed
Specification	IEC 60512-15-1:2008-05
Test force per pos.	20 N

1145402 DMC 0,5/ 4-G1SHL-2,54P20THRR24**13 Insertion and withdrawal forces**

Insertion and withdrawal force	
Specification	Test passed
No. of cycles	100
Insertion strength per pos. approx.	2 N
Withdraw strength per pos. approx.	1 N

1145402 DMC 0,5/ 4-G1SHL-2,54P20THRR24**14 Electrical tests****14.1 Electrical data**

Rated current / conductor cross section	6 A / 0.34 mm ²
Rated insulation voltage (III/2)	160 V
Rated surge voltage (III/2)	2.5 kV
Contact resistance	5.2 mΩ
Degree of pollution	2

14.2 Air and creepage distances

Component	PCB headers		
Specification	IEC 60664-1:2007-04		
Mains type	unearthed mains		
Insulating material group	IIIa		
Comparative tracking index (IEC 60112:2003-01)	CTI 175		
Rated insulation voltage	50 V	160 V	160 V
Rated surge voltage	0.8 kV	2.5 kV	1.5 kV
Degree of pollution	3	2	2
Overvoltage category	III	III	II
Minimum clearance case A (inhomogeneous field)	0.8 mm	1.5 mm	0.5 mm
Minimum value of the creepage path requirement in acc. with table	1.25 mm	1.6 mm	1.6 mm

1145402 DMC 0,5/ 4-G1SHL-2,54P20THRR24

15 Current carrying capacity/derating curves

Specification	IEC 61984:2008-10
Note	Representation based on IEC 60512-5-2:2002-02
Note	For number of positions, see diagram
Reduction factor	0.8
Conductor cross section	0.34 mm ²

Type: DMCC 0,5/...-ST-SHL 7,0-2,54 with DMC 0,5/...-G1SHL-2,54P20THRR...

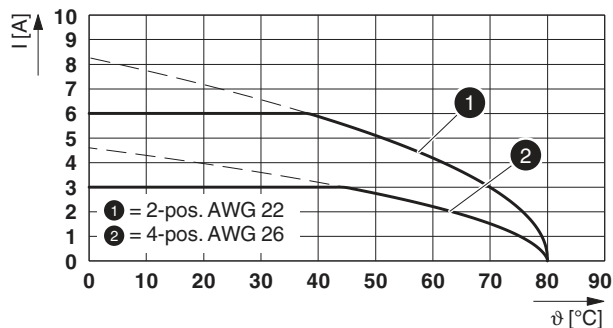

15.1 Vibration test

Specification	IEC 60068-2-6:2007-12
Result	Test passed
Frequency	10 - 150 - 10 Hz
Sweep speed	1 octave/min
Amplitude	0.35 mm (10 - 60.1 Hz)
Acceleration	50 m/s ² (60.1 - 150 Hz)
Test duration per axis	2.5 h
Test directions	X-, Y- and Z-axis
Note	The connected conductor loops were guided to the test sample at a distance of approx. 10 cm.

1145402 DMC 0,5/ 4-G1SHL-2,54P20THRR24

16 Approvals / Certificates

1145402 DMC 0,5/ 4-G1SHL-2,54P20THRR24**17 Commercial Data**

Order No.	1145402
Type	DMC 0,5/ 4-G1SHL-2,54P20THRR24
Pieces per package	300
Net weight	2.22 g
GTIN	4063151135744
	Information that applies locally, see link on page 1
Country of origin	Information that applies locally, see link on page 1

1145402 DMC 0,5/ 4-G1SHL-2,54P20THRR24

18 Combination tests



DMC 0,5/..-G1SHL-THR

IEC 61984	IEC 61984			
Mechanical tests (A)				
Insertion/withdrawal force per position	approx. 2 N / 1 N			
Polarization when inserted Requirement >20 N	Test passed			
Contact holder in insert Requirements >20 N	Test passed			
Durability tests (B)				
Contact resistance R ₁	5.2 mΩ			
Insertion/withdrawal cycles	100			
Contact resistance R ₂	4.6 mΩ			
Rated impulse voltage at sea level Voltage waveform ≥ (1.2/50 μs)	2.95 kV			
Power-frequency withstand voltage Voltage waveform ≥ (50/60 Hz)	1.39 kV			
Thermal tests (C)				
Tested number of positions	2			
Tested conductor cross section	0.34 mm ²			
Test current	6 A			
Upper limiting temperature Requirements < 100°C	Test passed			
Climatic tests (D)				
Test sequence 1: low temperature storage	-40 °C/2 h			
Test sequence 2: heat storage	80 °C/168 h			
Test sequence 3: noxious gas storage (ISO 6988)	0.2 dm ³ SO ₂ on 300 dm ³ / 40 °C/1 cycle			
Rated impulse voltage at sea level Voltage waveform ≥ (1.2/50 μs)	2.95 kV			
Power-frequency withstand voltage Voltage waveform ≥ (50/60 Hz)	1.39 kV			
Environmental and endurance tests (E)				
Specification	IEC 61984:2008-10			
Degree of protection	Finger safety with IP20 test finger			