

PART NUMBER	REVISION	DESCRIPTION	FEED TYPE
2151063-1	U	FINE CRIMP HEIGHT ADJUST	MECHANICAL
2151063-2	U	FINE CRIMP HEIGHT ADJUST	PNEUMATIC
5-2151063-1	U	SEAL STRIPPER CRIMPER TERMINATING UNIT	MECHANICAL
5-2151063-2	U	SEAL STRIPPER CRIMPER TERMINATING UNIT	PNEUMATIC
7-2151063-1	U	MECHANICAL AND CRIMP TOOLING KIT	MECHANICAL
7-2151063-2	U	PNEUMATIC AND CRIMP TOOLING KIT	PNEUMATIC
7-2151063-7	S	CRIMP TOOLING KIT	-

ATLANTIC VERSION TERMINATOR INTERFACE ADAPTER

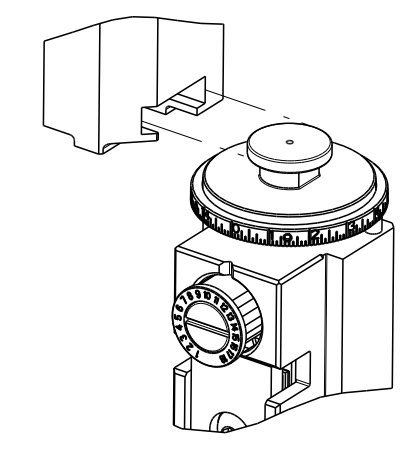

APPLICATOR DATA		
CRIMP	SIZE	TYPE
WIRE	2.54 mm [.100]	F
INSUL	4.19 mm [.165]	O

APPLICATOR INSTRUCTIONS 408-35042

TERMINAL DATA: TE TERMINAL		TE CRIMP SPECIFICATION	
TERMINAL NAME: JUNIOR-POWER-TIMER CONTACT A			
WIRE STRIP LENGTH		INSULATION DIAMETER RANGE	
4.60-5.20 mm [.181-.205 IN]	(A)114-18050	Ø2.20-3.00 mm [.087-.118 IN]	-
TERMINAL APPLICATION SPECIFICATION	(B)114-18051		
TERMINALS APPLIED			
TE TERMINAL	TE TERMINAL	TE SEAL	CABLE DIAMETER
(A)964273-1	(A)1241872-1	963292-1	Ø2.7-3.0
(A)964273-2	(A)4-1241872-1	963293-1	Ø2.0-2.7
(A)1-964273-1		963293-2	Ø2.0-2.7
(A)2-964273-1	(B)1-964302-3		
(A)3-964273-1	(B)2-964302-1		
(A)4-964273-1			
(A)6-964273-6			
WIRE SIZE	CRIMP HEIGHT mm [INCH]	CRIMP HEIGHT REFERENCE SETTING	
2.50mm2	1.76+/-0.05 [.069+/-0.002]	4.9	
2.00mm2	1.70+/-0.05 [.067+/-0.002]	5.6	
1.50mm2	1.47+/-0.05 [.058+/-0.002]	8.0	

TERMINAL DATA: TE TERMINAL		TE CRIMP SPECIFICATION	
TERMINAL NAME: JUNIOR-POWER-TIMER CONTACT A			
WIRE STRIP LENGTH		INSULATION DIAMETER RANGE	
4.20-4.80 mm [.165-.189 IN]	(C)114-18387	Ø2.20-3.00 mm [.087-.118 IN]	-
TERMINAL APPLICATION SPECIFICATION	(D)114-94365-02		
TERMINALS APPLIED			
TE TERMINAL	TE TERMINAL	TE SEAL	CABLE DIAMETER
		963292-1	Ø2.7-3.0
		963293-1	Ø2.0-2.7
(C)(D)1241396-1		963293-2	Ø2.0-2.7
(C)(D)1241396-2		(D)828905-1	Ø2.2-3.0
(C)(D)1241396-3			
WIRE SIZE	CRIMP HEIGHT mm [INCH]	CRIMP HEIGHT REFERENCE SETTING	
2.50mm2	1.76+/-0.05 [.069+/-0.002]	4.9	
2.00mm2	1.70+/-0.05 [.067+/-0.002]	5.6	
1.50mm2	1.47+/-0.05 [.058+/-0.002]	8.0	

- RECOMMENDED SPARE PARTS
 - REFER TO SUPPLIED INSTRUCTION SHEET FOR CLEANING, LUBRICATION AND STORAGE OF APPLICATOR.
 - APPLY PART NUMBER 1-23419-5 LOCTITE TO THREADS OF ITEM 180. APPLY PART NUMBER 2-23419-6 LOCTITE TO THREADS OF ITEM 242.
 - CRIMP HEIGHT REFERENCE SETTING WAS THE SETTING USED WHEN THE APPLICATOR WAS QUALIFIED AT THE FACTORY. ADJUSTMENT MAY BE NECESSARY WHEN RUNNING APPLICATOR IN THE FIELD.
 - APPLY TORQ-SEAL IN ALLEN SOCKET TO FILL HOLE AFTER FLAT HD HAS BEEN ADJUSTED TO CORRECT HEIGHT AT QUALIFICATION. APPLY #1-23419-5 LOC-TITE TO THREADS.
 - WHEN APPLYING TERMINAL PN 1241396-* APPLICATOR FEED WILL REQUIRED ADJUSTMENT TO 12.0mm (.472 IN).
 - TERMINAL LUBRICANT IS RECOMMENDED.
8. UNLESS SPECIFIED OTHERWISE TORQUE VALUES SHALL BE USED PER DOCUMENT, 101-35000.

***WARNING**
ON INSTALLATION, SET WIRE DISC TO CRIMP HEIGHT REFERENCE SETTING FOR LARGEST WIRE SIZE. CRIMP HEIGHT REFERENCE SETTINGS GREATER THAN THE VALUE SHOWN MAY CAUSE DAMAGE TO THE CRIMP TOOLING, REFER TO THE INSTRUCTION SHEET FOR PROPER SETUP AND ADJUSTMENTS.

ATLANTIC VERSION
Shown on sheets 1 of 4 & 2 of 4
(Pacific version shown on sheets 3 of 4 & 4 of 4)

LOC	DIST	REVISIONS					
A	66	P	LTN	DESCRIPTION	DATE	OWN	APVD
		S1		ECR-21-007083	29JUL2021	JWC	TE
		T		ECR-21-007116	02AUG2021	JWC	TE
		T1		ECR-22-133991	29MAR2022	JWC	RK
		U		ECR-22-134927	04APR2022	TB	GB

-	-	-	1	1	-	-	1803515-3	RAM ASSEMBLY, SF ATLANTIC	293
-	-	-	1	1	-	-	2-1803583-1	APPLICATOR BASIC ASSEMBLY, SF	292
-	1	-	1	-	1	-	2119641-1	FEED CAM, AIR FEED	248
-	1	1	1	1	1	1	2119082-3	CAM, SNAIL, INSULATION ADJUSTMENT	244
-	1	1	1	1	1	1	2079764-1	WASHER, WAVE SPRING, CREST-TO-CREST	243
-	1	1	1	1	1	1	2119083-1	RETAINER, INSULATION DIAL	242
-	1	1	1	1	1	1	7-18023-7	SCR, SKT HD CAP M3 X 4.0	241
-	-	1	-	1	-	1	2119580-1	MECHANICAL FEED ASSEMBLY	239
-	1	-	1	-	1	-	2844940-1	AIR FEED MODULE	238
-	-	-	1	1	-	-	4-1722335-3	STRIPPER, SIDE FEED	182
-	-	-	1	1	-	-	1-5018030-0	NUT, HEX, REG, RoHS, M3.5	181
-	-	-	1	1	-	-	2-1752354-2	STANDOFF, HOLD-DOWN	180
-	-	-	1	1	-	-	993111-1	PIN, SLOTTED SPRING 3.0 X 20.0	177
-	-	-	1	1	-	-	5-22280-0	SPRING, COMPRESSION	176
-	-	-	1	1	-	-	1752353-3	GUIDE PIN, HOLDDOWN	175
-	-	-	1	1	-	-	1901680-2	GUIDE PIN, HOLDDOWN	174
-	REF	REF	REF	REF	REF	REF	994970-2	COUNTER, MAGNETIC	164
-	1	1	1	1	1	1	2119955-1	ASSY, LUBRICATOR, SIDE FEED	113
-	1	1	1	1	1	1	2844908-1	SCREW, LOCKING	99
-	1	1	1	1	1	1	2844907-1	POST, LOCKING	98
-	1	1	1	1	1	1	455888-9	SPACER, CRIMPER	82
-	1	1	1	1	1	1	1803607-3	DOCUMENTATION PACKAGE	71
-	1	1	1	1	1	1	2119791-5	DEPRESSOR, WIRE	70
-	1	1	1	1	1	1	2119740-1	TAG, IDENTIFICATION	67
-	2	2	2	2	2	2	2168078-1	SCREW, DRIVE, RH, RoHS, 2 x .188	66
-	1	1	1	1	1	1	2168083-2	SCR, SKT HD CAP, RoHS, M4 X 8.0	60
-	1	1	1	1	1	1	5-18022-5	SCR, HEX HD CAP, M4 X 6.0	59
-	1	1	1	1	1	1	985575-4	SCR, FLT SKT HD CAP M3 X 12.0	57
-	1	1	1	1	1	1	1338685-1	PAWL, FEED	56
-	4	4	4	4	4	4	2168083-3	SCR, SKT HD CAP, RoHS, M4 X 12.0	54
-	2	2	2	2	2	2	2168083-3	SCR, SKT HD CAP, RoHS, M4 X 12.0	53
-	1	1	1	1	1	1	1803382-6	HOLD DOWN, SPRING LOADED	50
-	1	2	1	2	1	2	18023-9	SCR, SKT HD CAP M4 X 6.0	49
-	-	1	-	1	-	1	2119652-1	FEED CAM, PRE FEED	48
-	-	1	-	1	-	1	2119653-1	FEED CAM, POST FEED	47
-	1	1	-	-	1	1	1803583-9	APPLICATOR BASIC ASSEMBLY, SF	46
-	1	1	-	-	1	1	1803515-1	RAM ASSEMBLY, SF ATLANTIC	44
-	1	1	1	1	1	1	1803602-1	SCR, BHSC, RoHS (M8 X 25)	41
-	1	1	1	1	1	1	1752356-4	SUPPORT, TERMINAL	34
-	2	2	2	2	2	2	2079383-5	SCR, BHSC, RoHS (M4 X 20)	33
-	2	2	2	2	2	2	3-2844962-2	SPACER, CYLINDRICAL, STRIP GUIDE	30
-	1	1	1	1	1	1	2844992-2	ASSEMBLY, STRIP GUIDE	29
-	1	1	1	1	1	1	455888-3	SPACER, CRIMPER	28
-	1	1	1	1	1	1	1320928-4	STRIP GUIDE	24
-	1	1	-	-	1	1	2168083-2	SCR, SKT HD CAP, RoHS, M4 X 8.0	21
-	2	2	1	1	2	2	1-18028-2	WASHER, FLAT, REG M4	20
-	1	1	-	-	1	1	2119533-1	STRIPPER, SIDE FEED	19
-	1	1	1	1	1	1	2119806-1	INSERT, SHEAR	13
-	1	1	1	1	1	1	3-22280-3	SPRING, COMPRESSION	12
-	1	1	1	1	1	1	1-356885-4	STOP, SHEAR	11
-	1	1	1	1	1	1	2119805-1	SHEAR HOLDER, FRONT	10
-	1	1	1	1	1	1	318707-1	FLOATING SHEAR, FRONT	9
1	2	2	1	1	1	1	5-1333206-0	ANVIL, COMBINATION .100	8
-	1	1	1	1	1	1	6-240641-3	SPACER	7
-	1	1	1	1	1	1	2119781-5	DEPRESSOR, SHEAR	5
-	1	1	1	1	1	1	238011-4	BLOCK, CRIMPER SPACER	4
1	2	2	1	1	1	1	6-1633965-7	CRIMPER, INSULATION O PREMIUM	3
-	1	1	1	1	1	1	455888-3	SPACER, CRIMPER	2
1	2	2	1	1	1	1	1-456407-3	CRIMPER, WIRE PREMIUM	1

ITEM NO	PART NO	DESCRIPTION	ITEM NO
-77	-72	-71	-52
-51	-2	-1	

THIS DRAWING IS UNPUBLISHED. IT IS THE PROPERTY OF TFCO AND IS NOT TO BE REPRODUCED OR TRANSMITTED IN ANY FORM OR BY ANY MEANS, ELECTRONIC OR MECHANICAL, INCLUDING PHOTOCOPYING, RECORDING, OR BY ANY INFORMATION STORAGE AND RETRIEVAL SYSTEM. PERMISSION TO COPY OR REPRODUCE THIS DRAWING IN ANY MANNER IS GRANTED BY TFCO ONLY. ALL RIGHTS RESERVED.	OWN: H. HUANG 14SEP2011	TE Connectivity Harrisburg, PA 17105-3608
DIMENSIONS: mm	TOLERANCES UNLESS OTHERWISE SPECIFIED:	NAME: Ocean Side Feed Applicator
0 PLC ±	1 PLC ±	SIZE: A1
2 PLC ±	3 PLC ±	CAGE CODE: 00779
4 PLC ±	ANGLES ±	DRAWING NO: C=2151063
FINISH	FINISH	RESTRICTED TO: -
MATERIAL	WEIGHT	Customer Accessible Production Drawing
		SCALE: 1:2
		SHEET 1 OF 4
		REV U

LOC	DIST	REVISIONS					
A	66	P	LTN	DESCRIPTION	DATE	OWN	APVD
		-		SEE SHEET 1			

FEED TYPE MECHANICAL

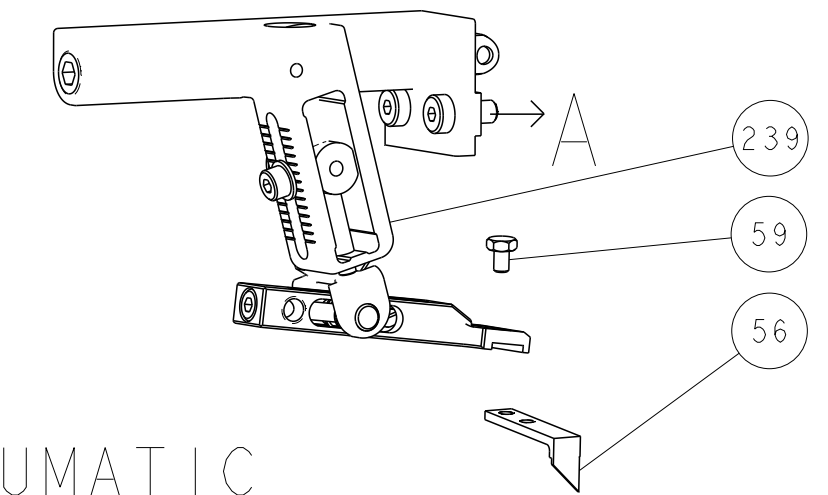

PNEUMATIC

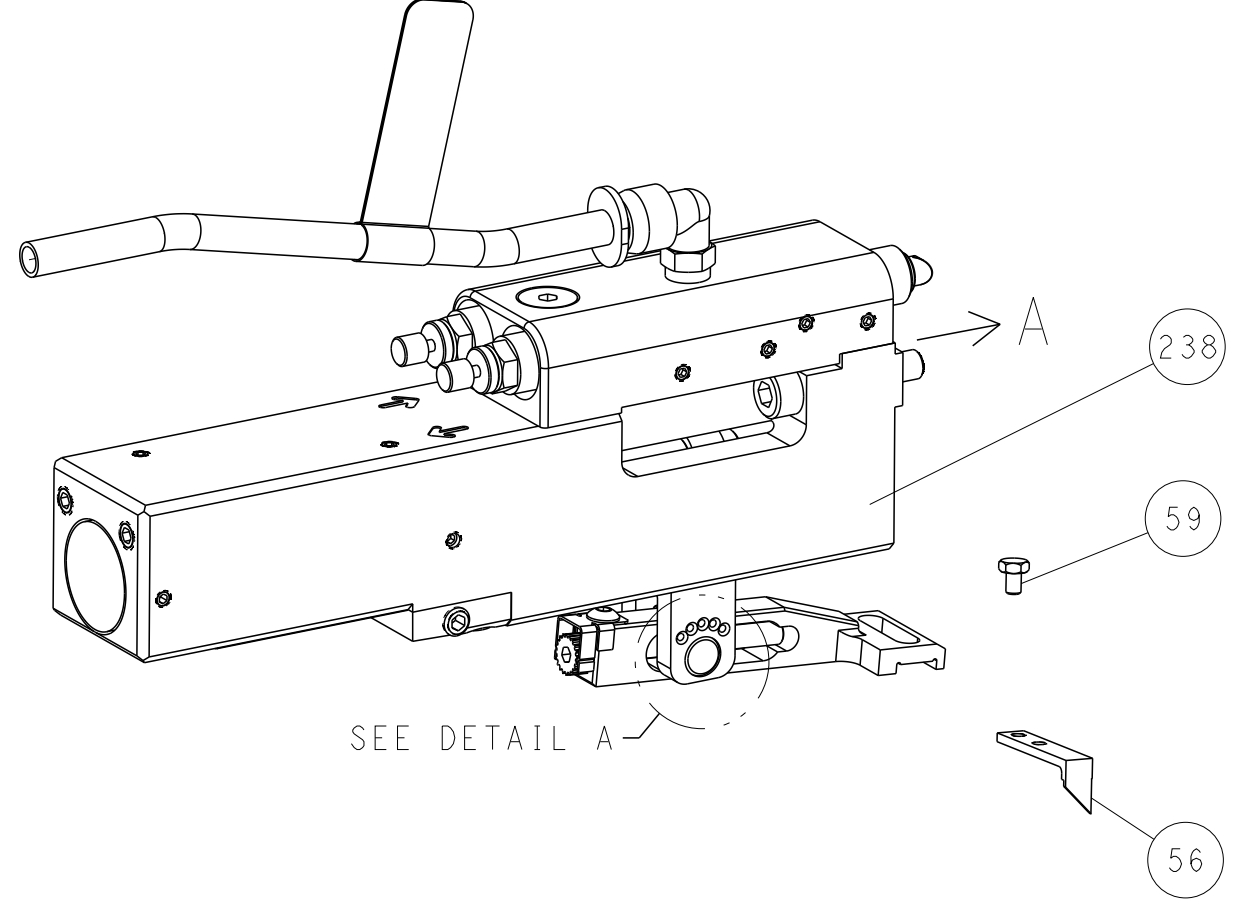

FEED SPRING SETTING POSITION (SHOWN FROM REAR SIDE)

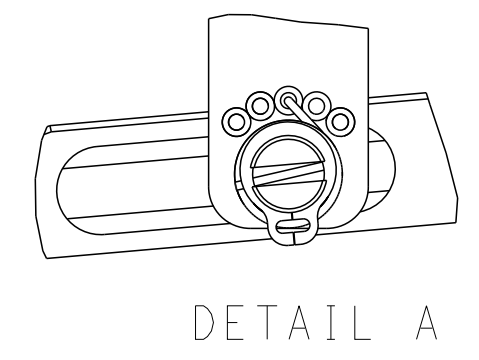

DETAIL A

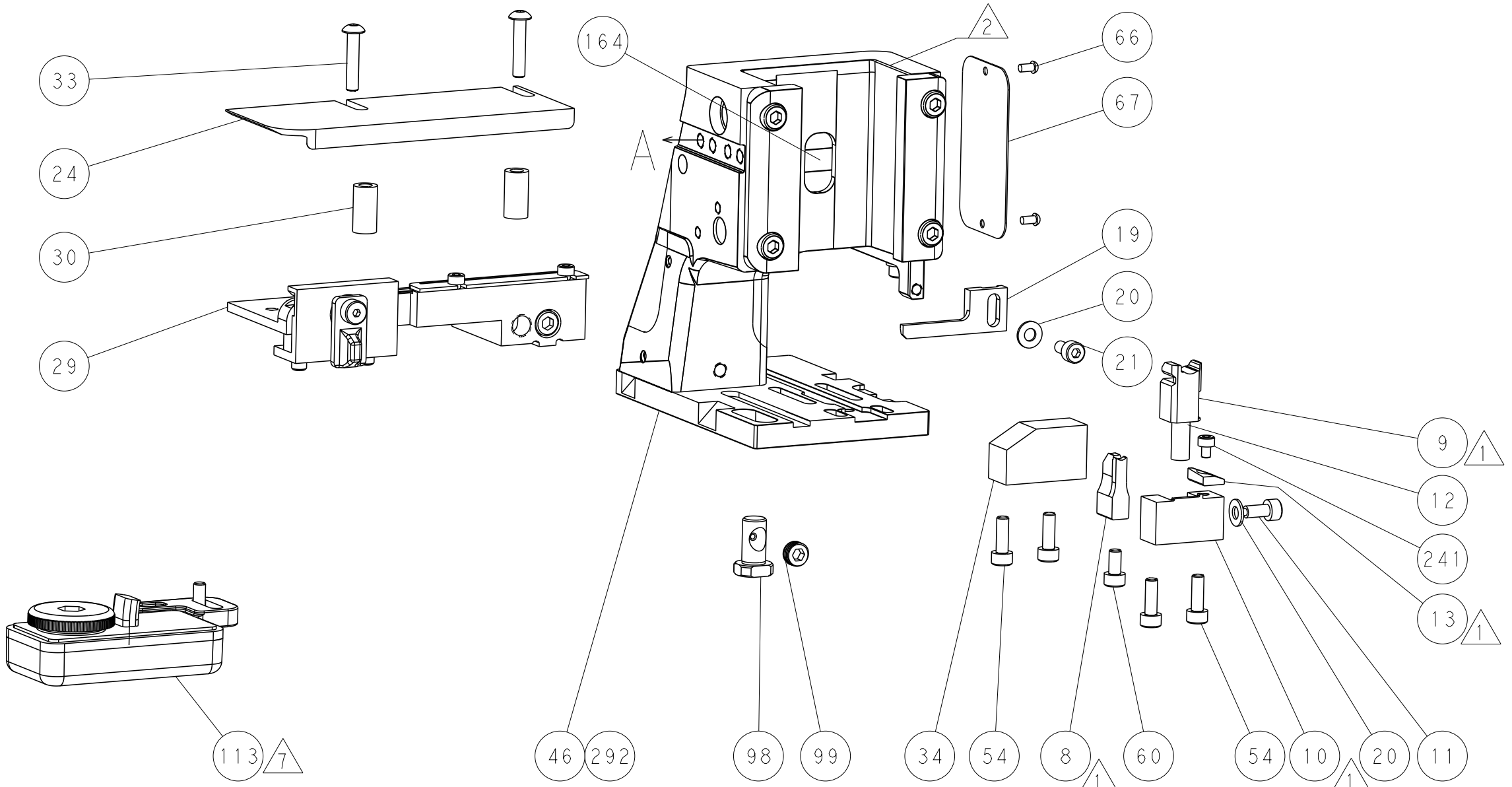
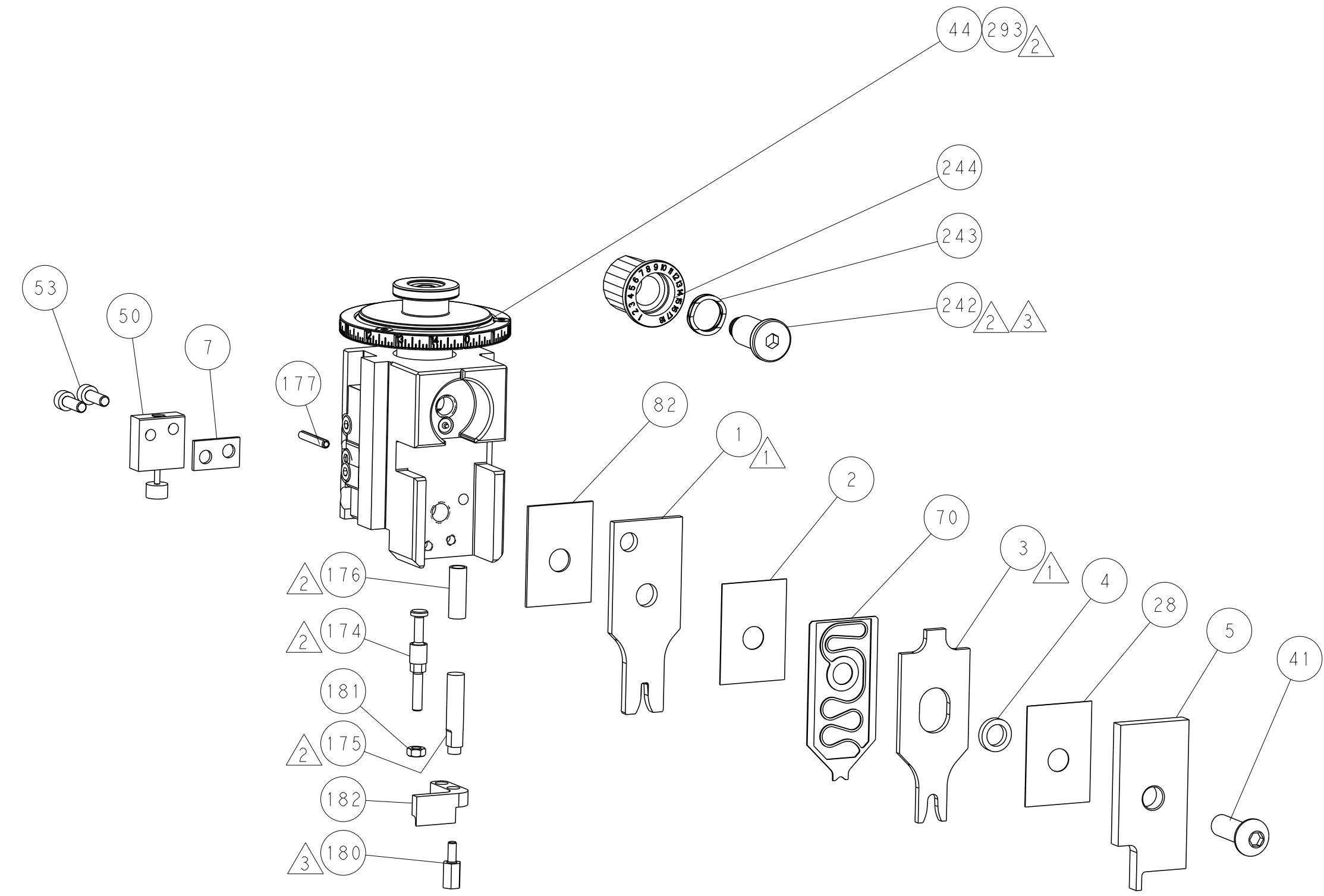
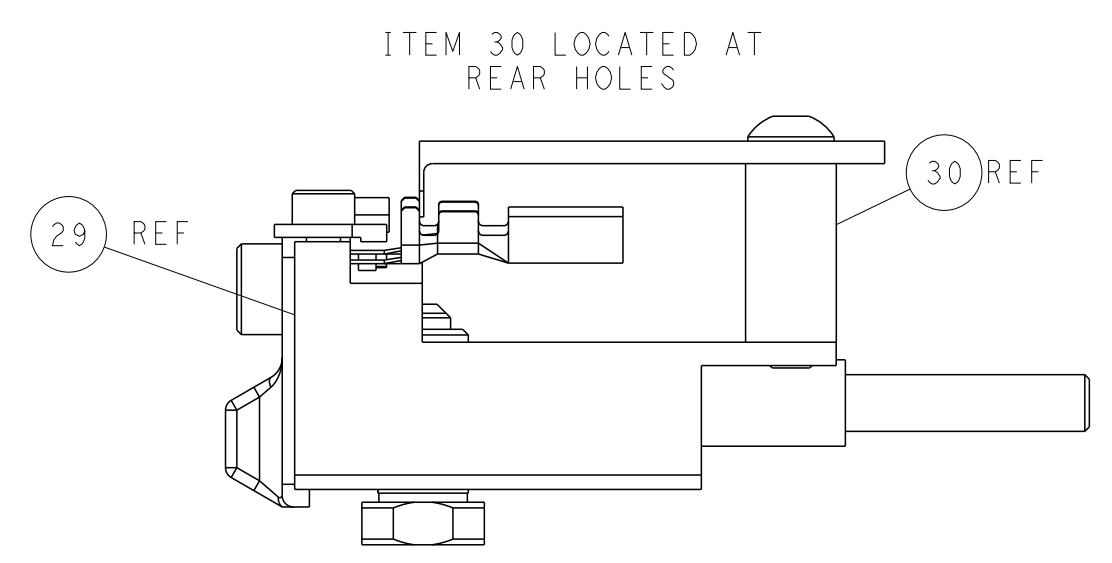
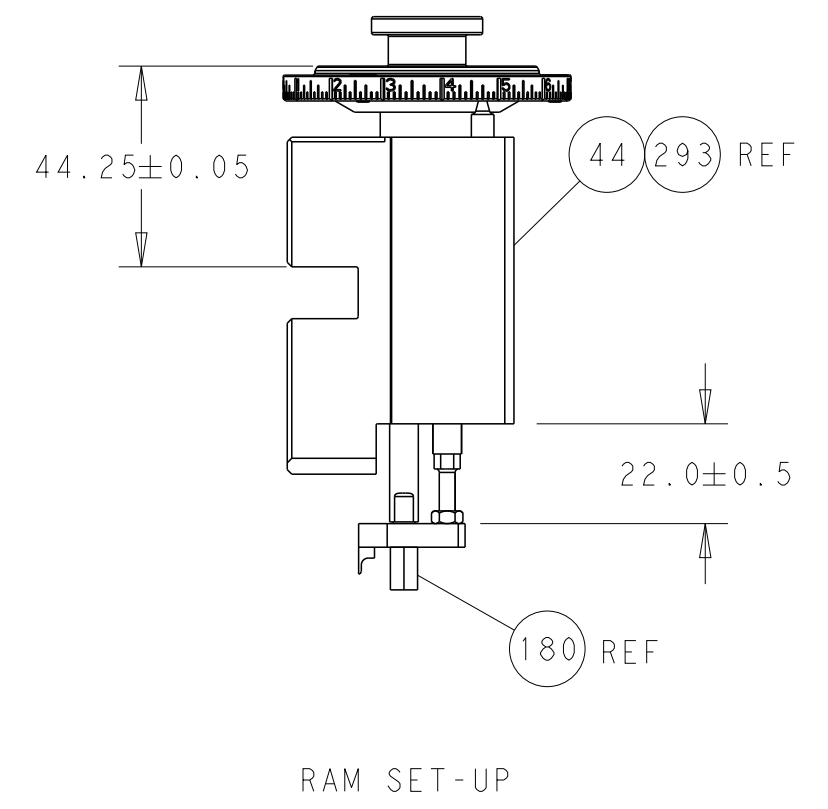
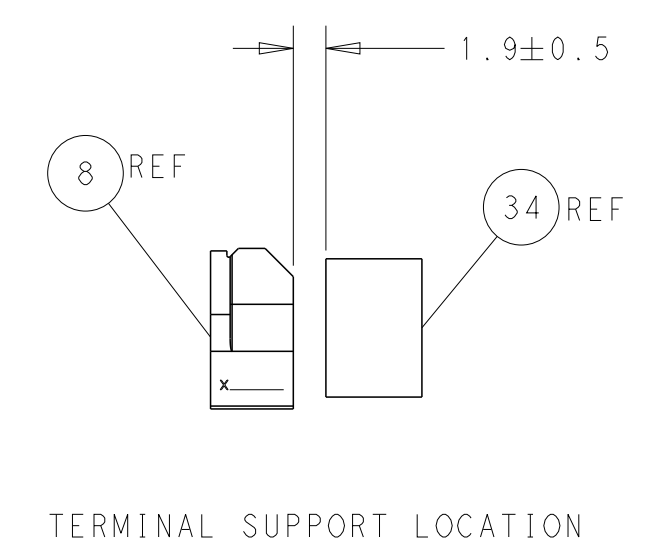
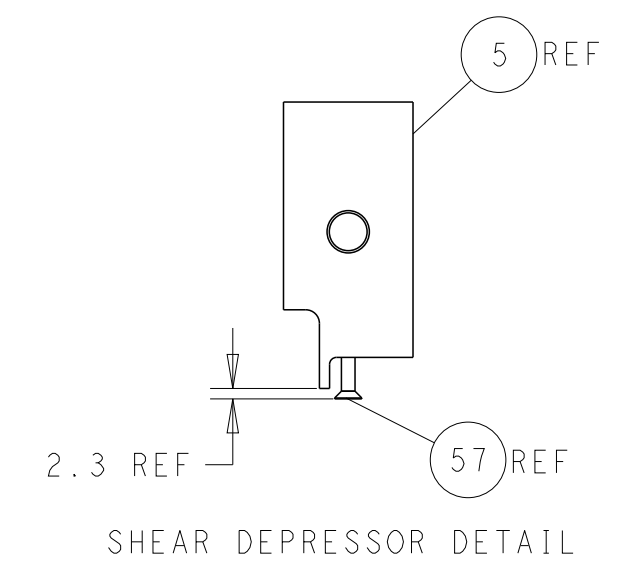

CAM POSITIONS

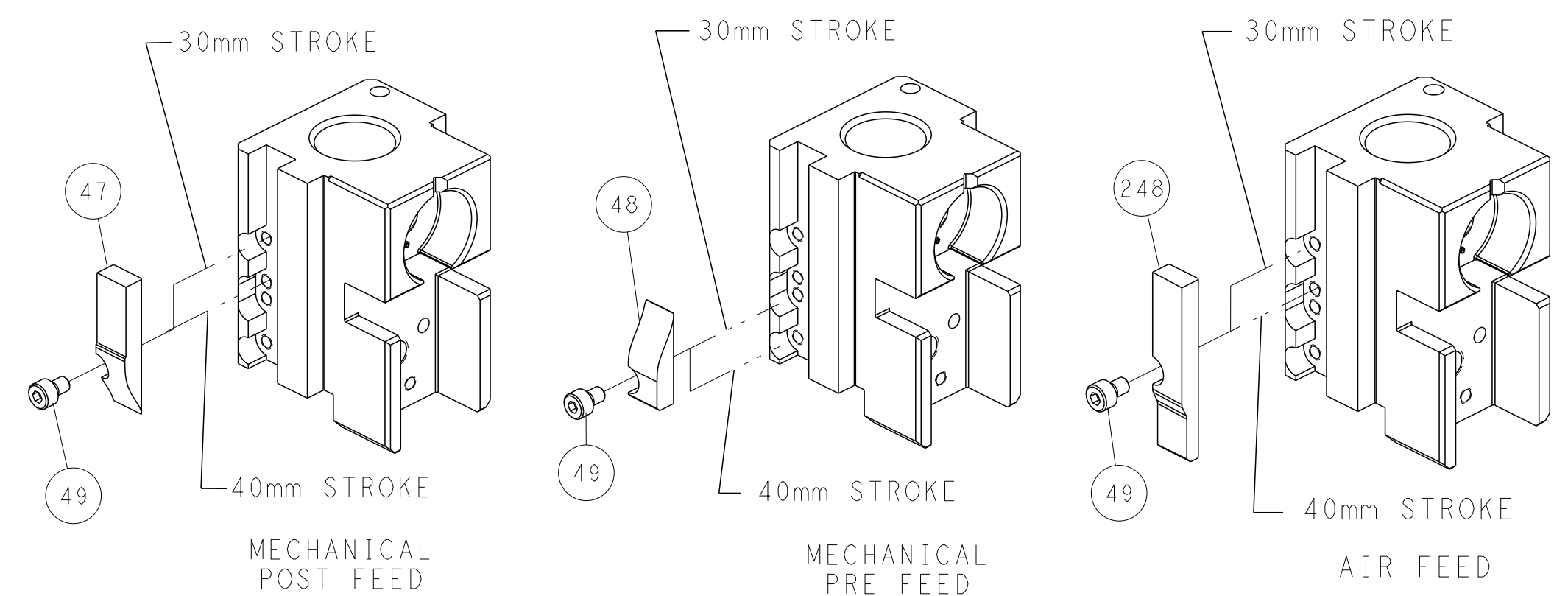

ATLANTIC VERSION
 Shown on sheets 1 of 4 & 2 of 4
 (Pacific version shown on sheets 3 of 4 & 4 of 4)

<small>THIS DRAWING IS UNPUBLISHED. RELEASED FOR PUBLICATION BY TYCO ELECTRONICS CORPORATION. ALL RIGHTS RESERVED.</small>		DWN: R. HUANG CHK: S. XI APVD: S. XI DATE: 14SEP2011	NAME: Ocean Side Feed Applicator SIZE: A1 CAGE CODE: 00779 DRAWING NO: 2151063	TE Connectivity Harrisburg, PA 17105-3608
DIMENSIONS: mm TOLERANCES UNLESS OTHERWISE SPECIFIED: 0 PLC ± 1 PLC ± 2 PLC ± 3 PLC ± 4 PLC ± ANGLES FINISH	WEIGHT: - SCALE: 1:2 SHEET: 2 of 4 REV: U	Customer Accessible Production Drawing		

PART NUMBER	REVISION	DESCRIPTION	FEED TYPE
2-2151063-1	U	FINE CRIMP HEIGHT ADJUST	MECHANICAL
2-2151063-2	U	FINE CRIMP HEIGHT ADJUST	PNEUMATIC
7-2151063-7	S	CRIMP TOOLING KIT	-

PACIFIC VERSION TERMINATOR
 INTERFACE ADAPTER

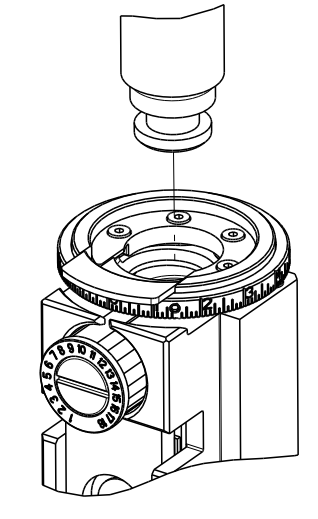

APPLICATOR DATA		
CRIMP	SIZE	TYPE
WIRE	2.54 mm [.100]	F
INSUL	4.19 mm [.165]	O
APPLICATOR INSTRUCTIONS 408-35042		

TERMINAL DATA: TE TERMINAL		TE CRIMP SPECIFICATION	
TERMINAL NAME: JUNIOR-POWER-TIMER CONTACT A			
WIRE STRIP LENGTH		INSULATION DIAMETER RANGE	
4.60-5.20 mm [1.81-.205 IN]		Ø2.20-3.00 mm [1.087-.118 IN]	
TERMINAL APPLICATION SPECIFICATION	(A)114-18050	-	-
	(B)114-18051	-	-
TERMINALS APPLIED			
TE TERMINAL	TE TERMINAL	TE SEAL	CABLE DIAMETER
(A)964273-1	(A)1241872-1	963292-1	Ø2.7-3.0
(A)964273-2	(A)4-1241872-1	963293-1	Ø2.0-2.7
(A)1-964273-1		963293-2	Ø2.0-2.7
(A)2-964273-1	(B)1-964302-3		
(A)3-964273-1	(B)2-964302-1		
(A)4-964273-1			
(A)6-964273-6			

TERMINAL DATA: TE TERMINAL		TE CRIMP SPECIFICATION	
TERMINAL NAME: JUNIOR-POWER-TIMER CONTACT A			
WIRE STRIP LENGTH		INSULATION DIAMETER RANGE	
4.20-4.80 mm [1.65-.189 IN]		Ø2.20-3.00 mm [1.087-.118 IN]	
TERMINAL APPLICATION SPECIFICATION	(C) 114-18387	-	-
	(D) 114-94365-02	-	-
TERMINALS APPLIED			
TE TERMINAL	TE TERMINAL	TE SEAL	CABLE DIAMETER
		963292-1	Ø2.7-3.0
		963293-1	Ø2.0-2.7
(C)(D)1241396-1		963293-2	Ø2.0-2.7
(C)(D)1241396-2		(D)828905-1	Ø2.2-3.0
(C)(D)1241396-3			

WIRE SIZE	CRIMP HEIGHT mm [INCH]	CRIMP HEIGHT REFERENCE SETTING
2.50mm2	1.76+/-0.05 [1.069+/-0.002]	4.9
2.00mm2	1.70+/-0.05 [1.067+/-0.002]	5.6
1.50mm2	1.47+/-0.05 [1.058+/-0.002]	8.0

WIRE SIZE	CRIMP HEIGHT mm [INCH]	CRIMP HEIGHT REFERENCE SETTING
2.50mm2	1.76+/-0.05 [1.069+/-0.002]	4.9
2.00mm2	1.70+/-0.05 [1.067+/-0.002]	5.6
1.50mm2	1.47+/-0.05 [1.058+/-0.002]	8.0

- RECOMMENDED SPARE PARTS
 - REFER TO SUPPLIED INSTRUCTION SHEET FOR CLEANING, LUBRICATION AND STORAGE OF APPLICATOR.
 - APPLY PART NUMBER 2-23419-6 LOCTITE TO THREADS OF ITEM 242.
 - CRIMP HEIGHT REFERENCE SETTING WAS THE SETTING USED WHEN THE APPLICATOR WAS QUALIFIED AT THE FACTORY. ADJUSTMENT MAY BE NECESSARY WHEN RUNNING APPLICATOR IN THE FIELD.
 - APPLY TORO-SEAL IN ALLEN SOCKET TO FILL HOLE AFTER FLAT HD HAS BEEN ADJUSTED TO CORRECT HEIGHT AT QUALIFICATION. APPLY #1-23419-5 LOC-TITE TO THREADS.
 - WHEN APPLYING TERMINAL PN 1241396-* APPLICATOR FEED WILL REQUIRED ADJUSTMENT TO 12.0mm [1.472 IN].
 - TERMINAL LUBRICANT IS RECOMMENDED.
8. UNLESS SPECIFIED OTHERWISE TORQUE VALUES SHALL BE USED PER DOCUMENT, 101-35000.

***WARNING**
 ON INSTALLATION, SET WIRE DISC TO CRIMP HEIGHT REFERENCE SETTING FOR LARGEST WIRE SIZE. CRIMP HEIGHT REFERENCE SETTINGS GREATER THAN THE VALUE SHOWN MAY CAUSE DAMAGE TO THE CRIMP TOOLING, REFER TO THE INSTRUCTION SHEET FOR PROPER SETUP AND ADJUSTMENTS.

ENTRY LEVEL APPLICATOR		ITEM SUBSTITUTION LIST		
PART NUMBER	SAME AS	ITEM	ITEM DESCRIPTION	SUBSTITUTE PART NUMBER
8-2151063-1	2151063-1	1	WIRE CRIMPER	1-1803552-3
8-2151063-2	2151063-2	3	INSULATION CRIMPER	6-1803624-7
9-2151063-1	2-2151063-1	46	BASIC SUB -ASSEMBLY	1803940-9
9-2151063-2	2-2151063-2	141	BASIC SUB -ASSEMBLY	1-1803940-0
			LUBRICATOR	DELETE

PACIFIC VERSION
 Shown on sheets 3 of 4 & 4 of 4
 (Atlantic version shown on sheets 1 of 4 & 2 of 4)

LOC	DIST	REVISIONS			
A	66	P LTR	DESCRIPTION	DATE	OWN
		-	SEE SHEET 1	-	-

-	1	1	2119082-3	CAM, SNAIL, INSULATION ADJUSTMENT	244
-	1	1	2079764-1	WASHER, WAVE SPRING, CREST-TO-CREST	243
-	1	1	2119083-1	RETAINER, INSULATION DIAL	242
-	1	1	7-18023-7	SCR, SKT HD CAP M3 X 4.0	241
-	-	1	2119580-1	MECHANICAL FEED ASSEMBLY	239
-	1	-	2844940-1	AIR FEED MODULE	238
-	REF	REF	994970-2	COUNTER, MAGNETIC	164
-	1	-	2119641-2	FEED CAM, AIR FEED	151
-	1	1	2168083-8	SCR, SKT HD CAP, RoHS, M4 X 16	144
-	4	4	2168083-9	SCR, SKT HD CAP, RoHS, M4 X 20	143
-	-	1	2119653-2	FEED CAM, POST FEED	142
-	1	1	1-1803583-0	APPLICATOR BASIC ASSEMBLY, SF	141
-	1	1	1803516-1	RAM ASSEMBLY, SF PACIFIC	140
-	1	1	2119955-1	ASSY, LUBRICATOR, SIDE FEED	113
-	1	1	2844908-1	SCREW, LOCKING	99
-	1	1	2844907-1	POST, LOCKING	98
-	1	1	455888-9	SPACER, CRIMPER	82
-	1	1	1803607-3	DOCUMENTATION PACKAGE	71
-	1	1	2119791-5	DEPRESSOR, WIRE	70
-	1	1	2119740-1	TAG, IDENTIFICATION	67
-	2	2	2168078-1	SCREW, DRIVE, RH, RoHS, 2 x .188	66
-	1	1	5-18022-5	SCR, HEX HD CAP, M4 X 6.0	59
-	1	1	985575-4	SCR, FLT SKT HD CAP M3 X 12.0	57
-	1	1	1338685-1	PAWL, FEED	56
-	2	2	2168083-3	SCR, SKT HD CAP, RoHS, M4 X 12.0	53
-	1	1	1803382-6	HOLD DOWN, SPRING LOADED	50
-	1	2	18023-9	SCR, SKT HD CAP M4 X 6.0	49
-	-	1	2119652-1	FEED CAM, PRE FEED	48
-	1	1	1803602-1	SCR, BHSC, RoHS (M8 X 25)	41
-	1	1	1752356-4	SUPPORT, TERMINAL	34
-	2	2	2079383-5	SCR, BHSC, RoHS (M4 X 20)	33
-	2	2	3-2844962-2	SPACER, CYLINDRICAL, STRIP GUIDE	30
-	1	1	2844992-2	ASSEMBLY, STRIP GUIDE	29
-	1	1	455888-3	SPACER, CRIMPER	28
-	1	1	1320928-4	STRIP GUIDE	24
-	1	1	2168083-2	SCR, SKT HD CAP, RoHS, M4 X 8.0	21
-	2	2	1-18028-2	WASHER, FLAT, REG M4	20
-	1	1	2119533-1	STRIPPER, SIDE FEED	19
-	1	1	2119806-1	INSERT, SHEAR	13
-	1	1	3-22280-3	SPRING, COMPRESSION	12
-	1	1	1-356885-4	STOP, SHEAR	11
-	1	1	2119805-1	SHEAR HOLDER, FRONT	10
-	1	1	318707-1	FLOATING SHEAR, FRONT	9
-	1	1	5-1333206-0	ANVIL, COMBINATION .100	8
-	1	1	6-240641-3	SPACER	7
-	1	1	2119781-5	DEPRESSOR, SHEAR	5
-	1	1	238011-4	BLOCK, CRIMPER SPACER	4
-	1	1	6-1633965-7	CRIMPER, INSULATION O PREMIUM	3
-	1	1	455888-3	SPACER, CRIMPER	2
-	1	1	1-456407-3	CRIMPER, WIRE PREMIUM	1

DIMENSIONS:		TOLERANCES UNLESS OTHERWISE SPECIFIED:		DWG		REV	
mm	0 PLC ±	1 PLC ±	2 PLC ±	3 PLC ±	4 PLC ±	5 PLC ±	6 PLC ±
	ANGLES						
	FINISH						
MATERIAL		WEIGHT		SCALE		SHEET	
				1:2		3	

LOC	DIST	REVISIONS					
A	66	P	LTN	DESCRIPTION	DATE	OWN	APVD
		-		SEE SHEET 1			

FEED TYPE MECHANICAL

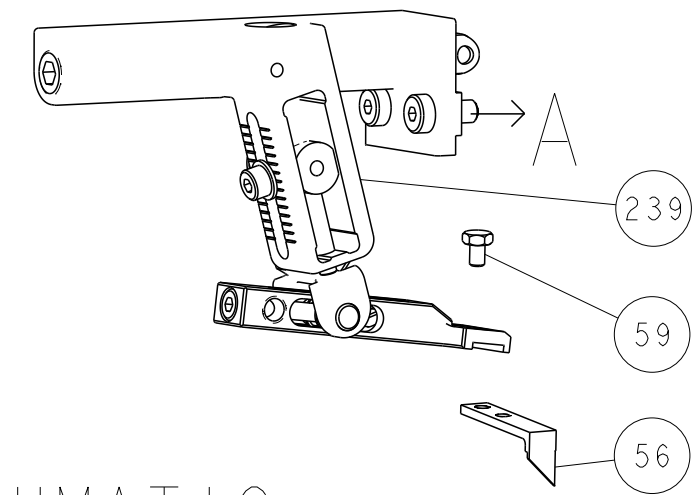

PNEUMATIC

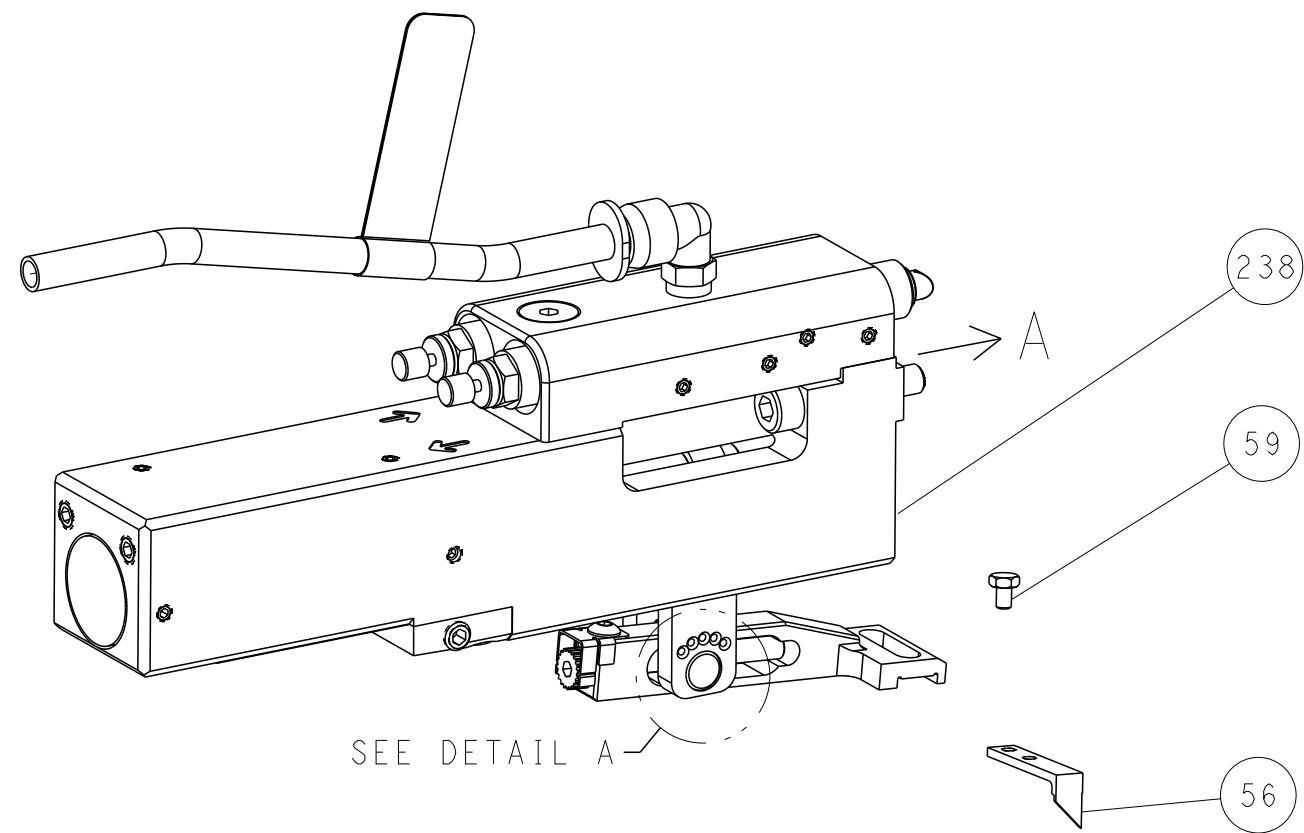

FEED SPRING SETTING POSITION (SHOWN FROM REAR SIDE)

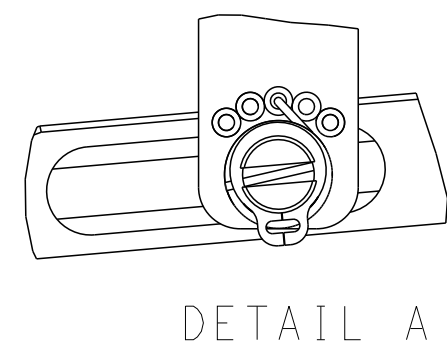

DETAIL A

CAM POSITIONS

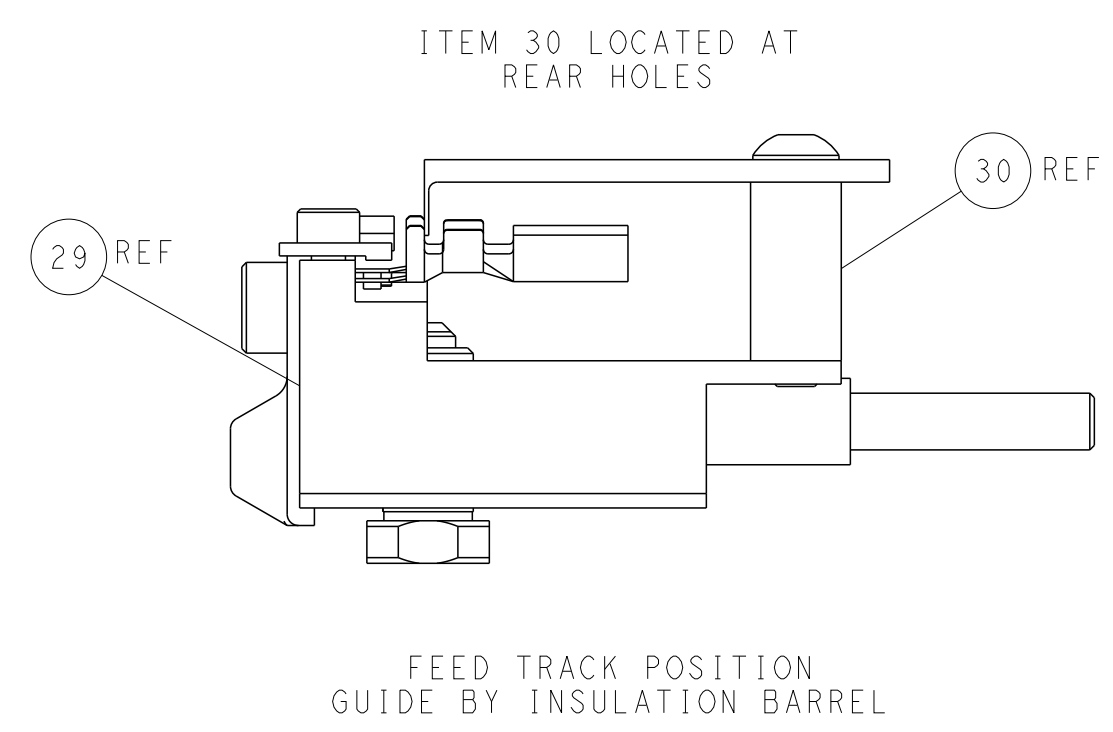
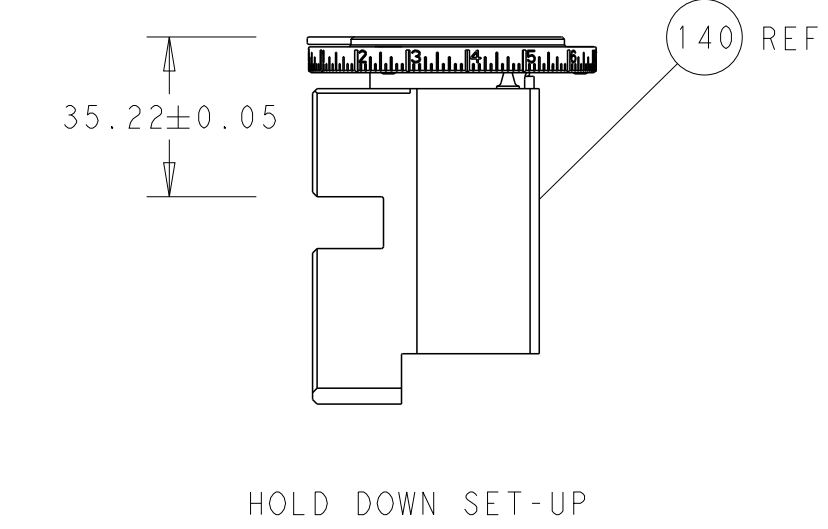
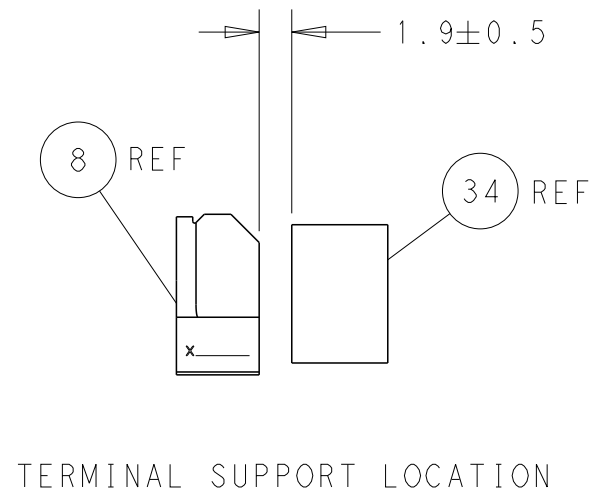
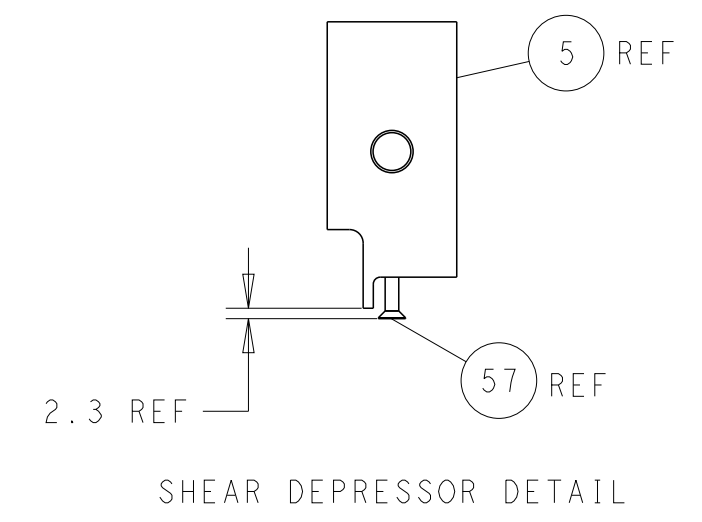
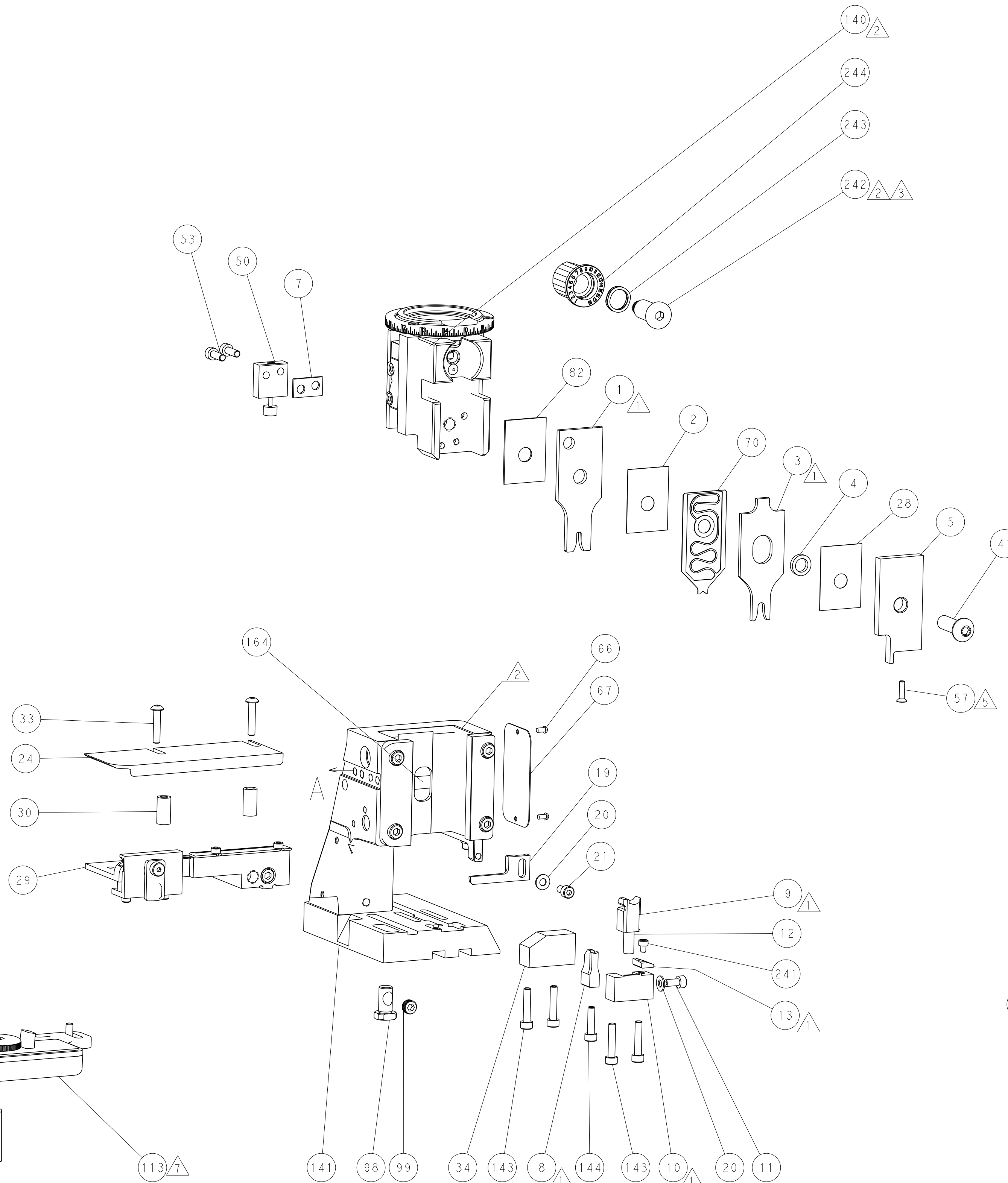
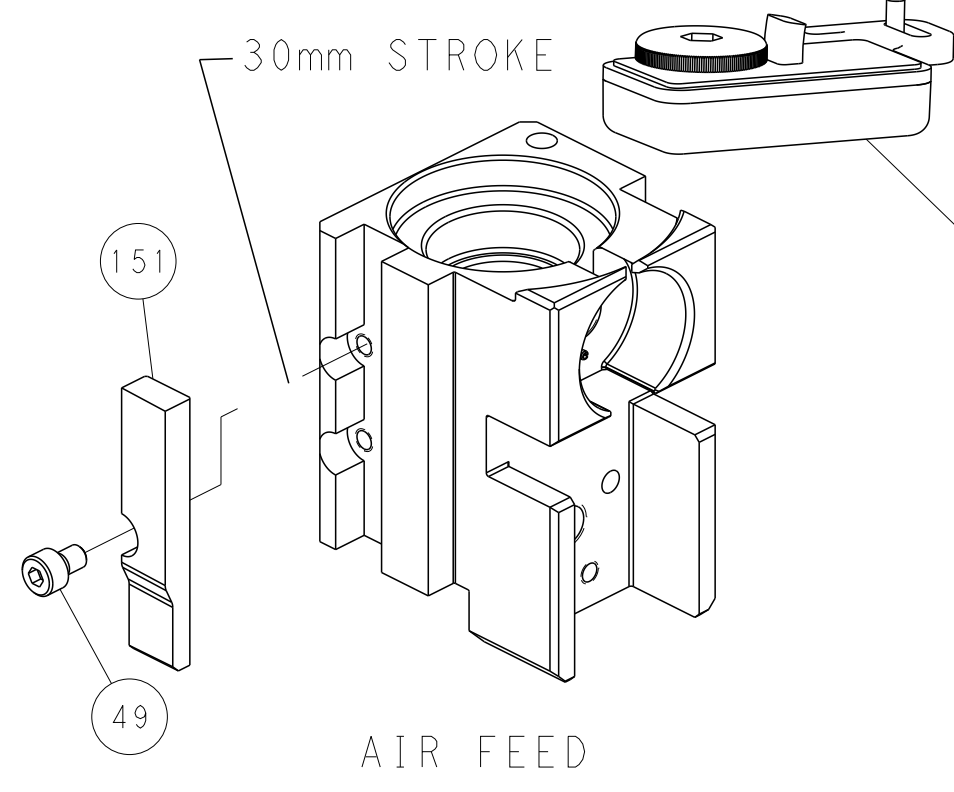
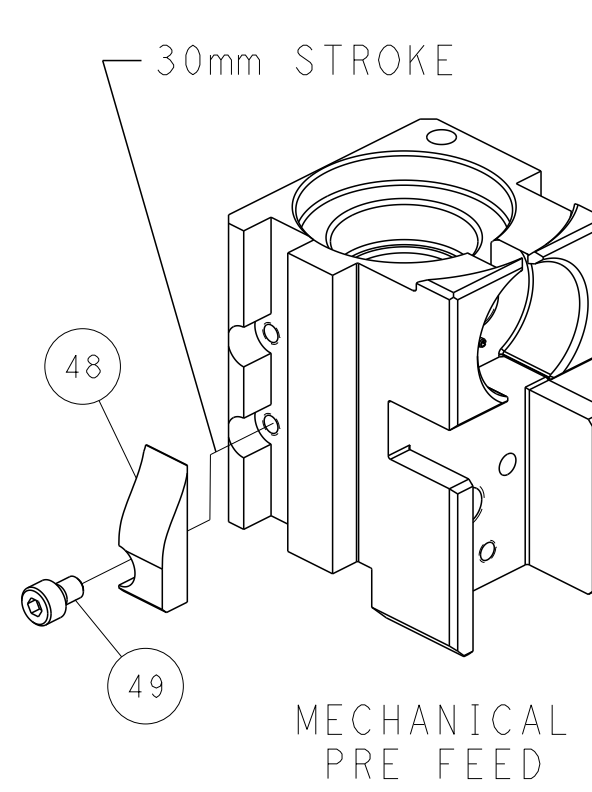
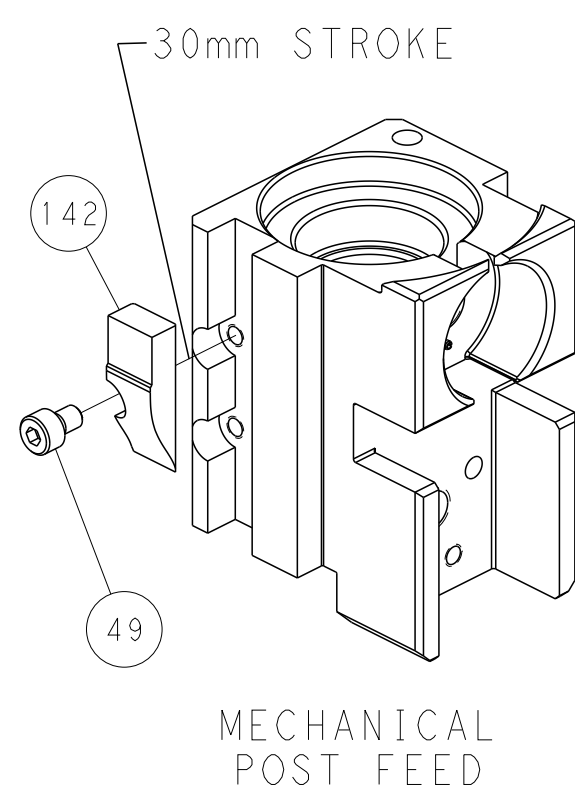

PACIFIC VERSION
 Shown on sheets 3 of 4 & 4 of 4
 (Atlantic version shown on sheets 1 of 4 & 2 of 4)

DIMENSIONS:		TOLERANCES UNLESS OTHERWISE SPECIFIED:		OWN: H. HUANG	DATE: 14SEP2011	TE Connectivity Harrisburg, PA 17105-3608
mm	0 PLC ±	1 PLC ±	2 PLC ±	APVD: S. XI	DATE: 14SEP2011	
	3 PLC ±	4 PLC ±	5 PLC ±	NAME: Ocean Side Feed Applicator		
	6 PLC ±	7 PLC ±	8 PLC ±	APPLICATION SPEC:		
MATERIAL:	FINISH:	WEIGHT:	SCALE: 1:2	SIZE: A1	CAGE CODE: 00779	DRAWING NO: C-2151063
Customer Accessible Production Drawing				SHEET 4 OF 4	REV U	RESTRICTED TO: