

LOC	DIST	P	F	ZONE	LTR	DESCRIPTION	DATE	APPD
AD	00							
					N	REDRAWN PER 0010-0052-94	3/4/94	HR
					P	REVISED PER 0010-0683-94	9/20/94	HR
					R	REVISED RER 0010-0812-95	9-22-95	PEB
					S	REVISED RER 0010-0862-95	9/27/95	RB HR
					T	REVISED PER 0010-0818-95	1-4-95	PB HR
					U	REV PER EC 0320-349-97	31 OCT 97	NS
					V	REV PER EC 0652-84-98	09 SEP 98	HR
					W	REV PER EC 0652-0008-99	03/08/99	CB

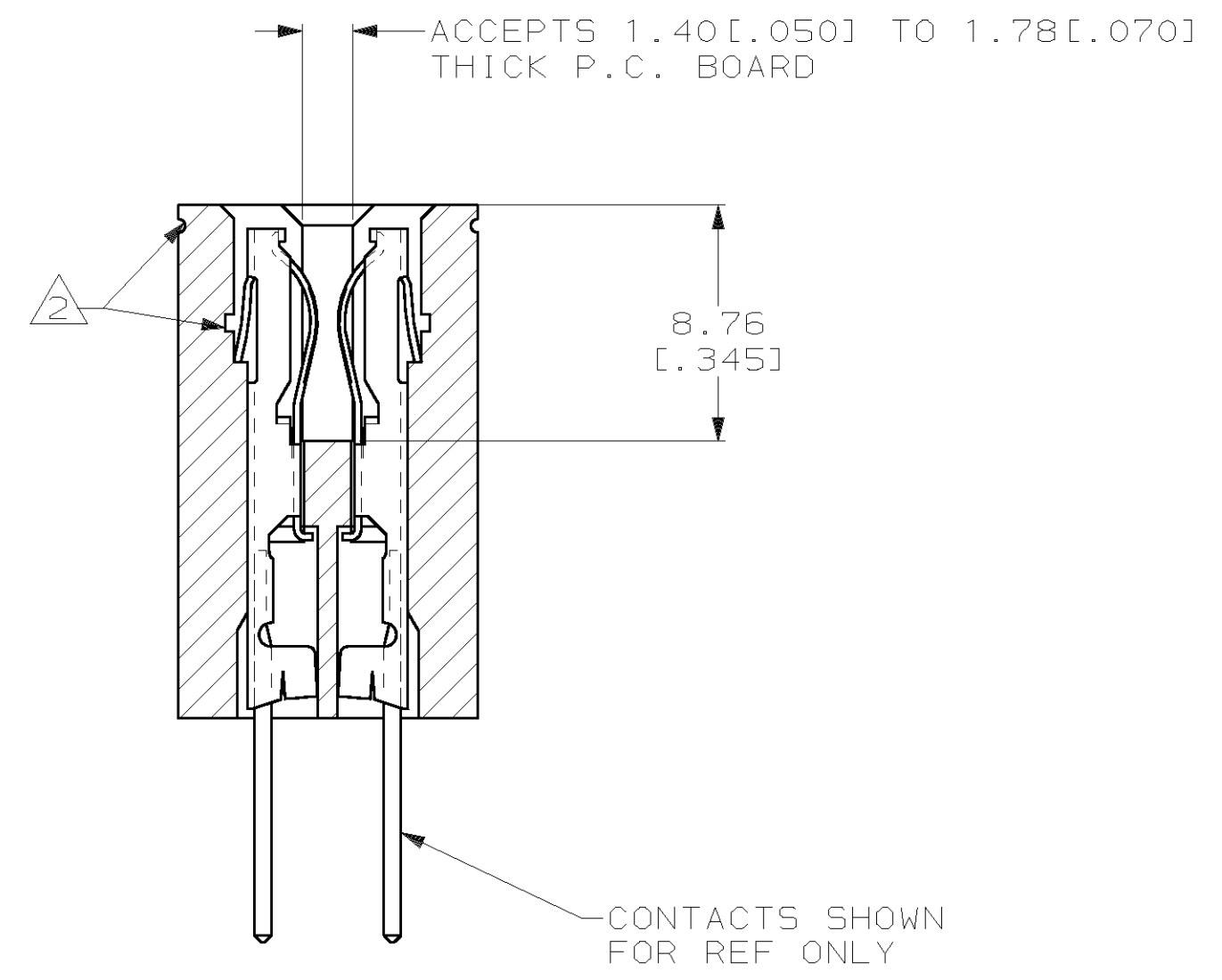

SECTION Z-Z

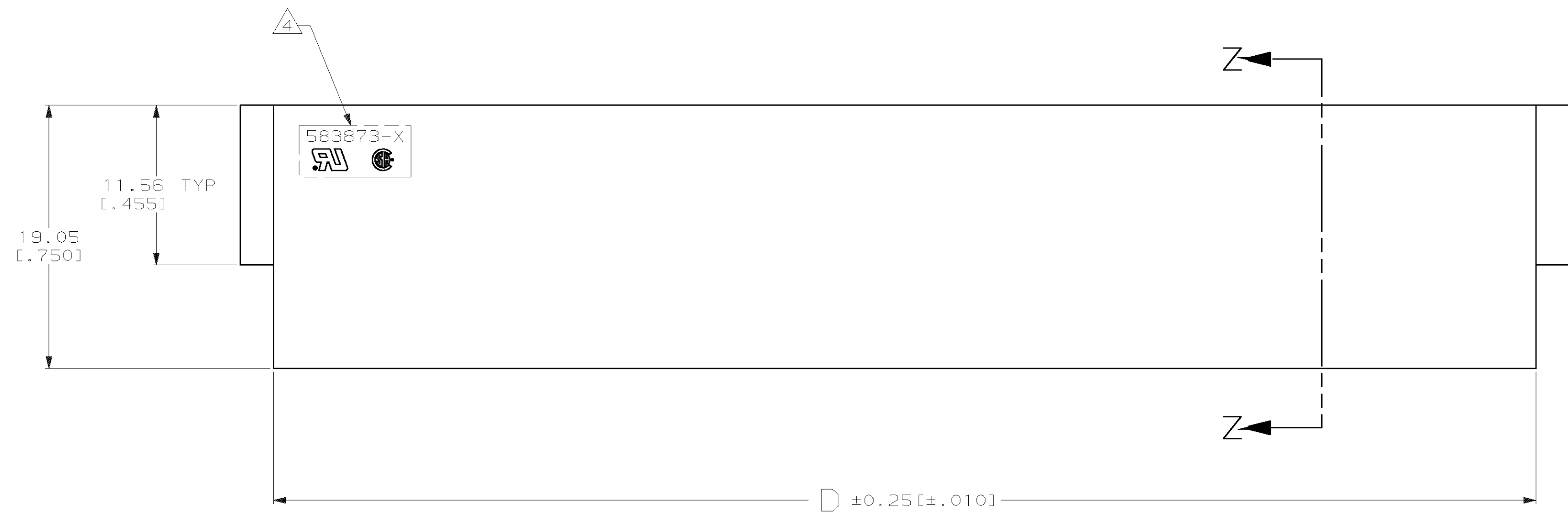
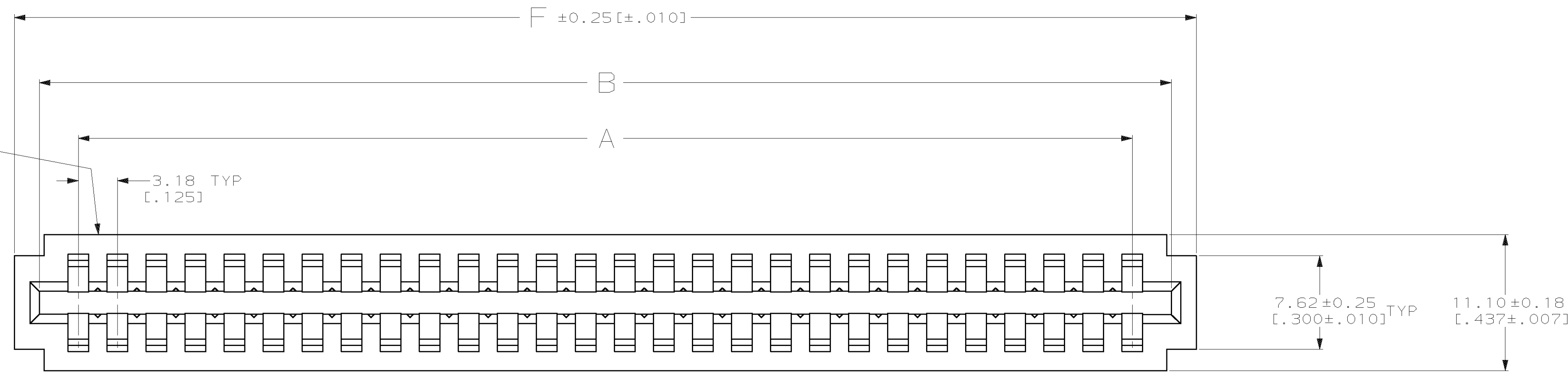
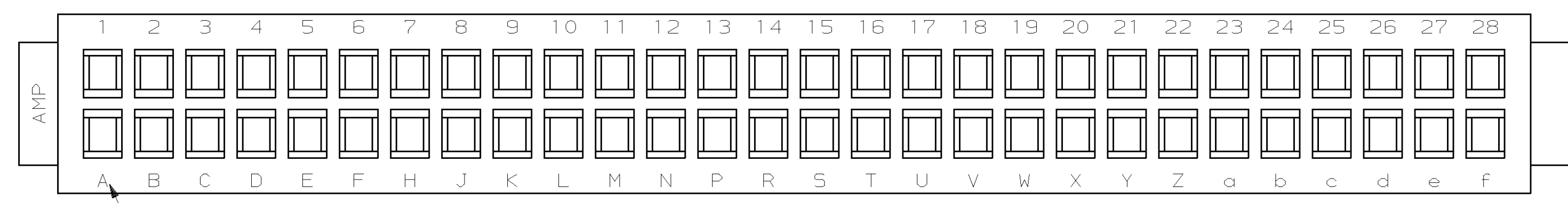

THIS DRAWING IS A CONTROLLED DOCUMENT FOR AMP INCORPORATED. IT IS SUBJECT TO CHANGE AND THE CONTROLLING ENGINEERING ORGANIZATION SHOULD BE CONTACTED FOR THE LATEST REVISION.

DO NOT SCALE PRINT. UNLESS SPECIFIED DIMENSIONS IN mm [INCHES] TOLERANCES - ON : 2 PLC DEC ± - 3 PLC DEC ± 0.13[.005] ANGLES ± -		DR 12-9-92 J GALLUCCI B6	PART NO	
MATERIAL GLASS FILLED POLYESTER COLOR: BLACK	FINISH -	CHK 3/4/94 H ROSE	APPD 3/4/94 H ROSE	AMP Incorporated Harrisburg, PA 17105-3508 NAME HOUSING, CRIMP SNAP TWIN LEAF, .125¢ WITHOUT MOUNTING EARS
		APPD 3/4/94 M THUMMA	PRODUCT SPEC -	
		APPLICATION SPEC -	WEIGHT -	SIZE D CAGE CODE 00779 DRAWING NO C-583873 SCALE 4:1 SHEET 1 OF 2

LOC		DIST		P		ZONE		LTR		REVISIONS		
AD	00									DESCRIPTION	DATE	APPD
										W SEE SHEET 1	-	-

- ① FIRST 22 POSITIONS MARKED WITH UPPER CASE LETTERS, FOLLOWED BY LOWER CASE LETTERS, FOLLOWED BY UPPERCASE AA, AB, AC ETC. CHARACTERS G, I, O AND Q ARE OMITTED.
- ② PULL GROOVES OPTIONAL THESE LOCATIONS REF ONLY.
- ③ HOUSING PART NUMBER, UL & CSA LOGO'S TO BE MOLDED IN THIS AREA. UL LOGO PER 1-18838-3, CSA LOGO PER 1-18839-3.
- ④ SPECIAL MARKING STAMPED BOTH SIDES FOR 2-583873-3
- ⑤ DATE CODE TO BE MOLDED IN THIS AREA



2-583783-3 ④

OBSOLETE	④	96.14	91.31	92.08	85.73	28	2-583783-3
		[3.785]	[3.595]	[3.625]	[3.375]		
OBSOLETE		102.49	97.66	98.43	92.08	30	2-583783-1
		[4.035]	[3.845]	[3.875]	[3.625]		
		146.94	142.11	142.88	136.53	44	1-583783-9
		[5.785]	[5.595]	[5.625]	[5.375]		
OBSOLETE		134.24	129.41	130.18	123.83	40	1-583783-7
		[5.285]	[5.095]	[5.125]	[4.875]		
OBSOLETE		105.66	100.84	101.60	95.25	31	1-583783-5
		[4.160]	[3.970]	[4.000]	[3.750]		
OBSOLETE		96.14	91.31	92.08	85.73	28	1-583783-3
		[3.785]	[3.595]	[3.625]	[3.375]		
OBSOLETE		86.61	81.79	82.55	76.20	25	1-583783-1
		[3.410]	[3.220]	[3.250]	[3.000]		
		77.09	72.26	73.03	66.68	22	583783-9
		[3.035]	[2.845]	[2.875]	[2.625]		
OBSOLETE		64.39	59.56	65.41	53.98	18	583783-7
		[2.535]	[2.345]	[2.575]	[2.125]		
		54.86	50.04	50.80	44.45	15	583783-5
		[2.160]	[1.970]	[2.000]	[1.750]		
OBSOLETE		38.99	34.16	34.93	28.58	10	583783-3
		[1.535]	[1.345]	[1.375]	[1.125]		
		26.29	21.46	22.23	15.88	6	583783-1
		[1.035]	[.845]	[.875]	[.625]		
		F	D	B	A	POSN	PART NUMBER

DO NOT SCALE PRINT. UNLESS SPECIFIED DIMENSIONS IN mm [INCHES]		DR 12-9-92 J GALLUCCI BG		AMP AMP Incorporated Harrisburg, PA 17105-3508	
TOLERANCES ON:	CHK 3/4/94 H ROSE	NAME			
2 PLC DEC ± -	APPD 3/4/94 H ROSE	HOUSING, CRIMP SNAP			
3 PLC DEC ± -	APPD 3/4/94 M THUMMA	TWIN LEAF, .125¢			
ANGLES ± -	PRODUCT SPEC	WITHOUT MOUNTING EARS			
MATERIAL	APPLICATION SPEC	SIZE	CAGE CODE	DRAWING NO	
-	-	D	00779	C-583873	
FINISH	WEIGHT	SCALE	SHEET	PART NO	
-	-	4:1	20F2	CUSTOMER DRAWING	

THIS DRAWING IS A CONTROLLED DOCUMENT FOR AMP INCORPORATED. IT IS SUBJECT TO CHANGE AND THE CONTROLLING ENGINEERING ORGANIZATION SHOULD BE CONTACTED FOR THE LATEST REVISION.