

ASSEMBLY MATERIAL NO. (STANDARD)	ASSEMBLY MATERIAL NO. (-G30 OPTION)	NUMBER OF CIRCUITS "XX"	DIM. "A"	DIM. "B"	DIM. "C"
399900302	399910302	02	10.8 [.42]	5.00 [.197]	5.00 [.197]
399900303	399910303	03	15.8 [.62]	10.01 [.394]	10.01 [.394]
399900304	399910304	04	20.8 [.82]	15.01 [.591]	10.01 [.394]
399900305	399910305	05	25.8 [1.02]	20.02 [.788]	10.01 [.394]
399900306	399910306	06	30.8 [1.21]	25.02 [.985]	15.01 [.591]
399900307	399910307	07	35.8 [1.41]	30.02 [1.182]	15.01 [.591]
399900308	399910308	08	40.8 [1.61]	35.03 [1.379]	20.02 [.788]
399900309	399910309	09	45.8 [1.80]	40.03 [1.576]	20.02 [.788]
399900310	399910310	10	50.8 [2.00]	45.03 [1.773]	25.02 [.985]
399900311	399910311	11	55.8 [2.20]	50.04 [1.970]	25.02 [.985]
399900312	399910312	12	60.8 [2.39]	55.04 [2.167]	30.02 [1.182]
399900313	399910313	13	65.8 [2.59]	60.05 [2.364]	30.02 [1.182]
399900314	399910314	14	70.8 [2.79]	65.05 [2.561]	35.03 [1.379]
399900315	399910315	15	75.8 [2.99]	70.05 [2.758]	35.03 [1.379]
399900316	399910316	16	80.8 [3.18]	75.06 [2.955]	40.03 [1.576]
399900317	399910317	17	85.8 [3.38]	80.06 [3.152]	40.03 [1.576]
399900318	399910318	18	90.8 [3.58]	85.06 [3.349]	45.03 [1.773]

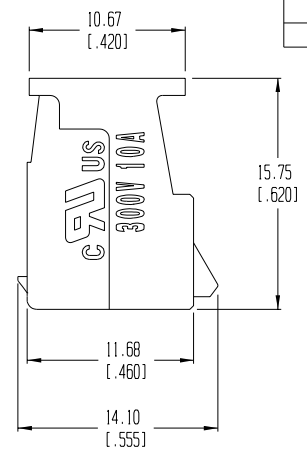

WINDOW ON PLUG ALIGNS WITH SNAP ON HEADER ALWAYS CENTERED ON PART OR THE CIRCUIT TO THE LEFT OF CENTER

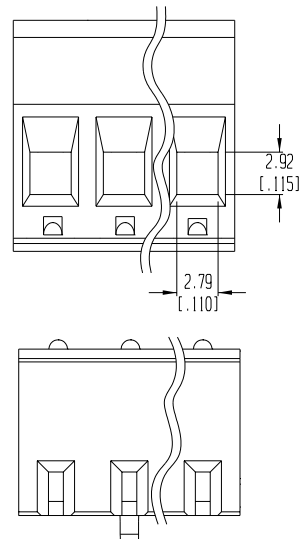
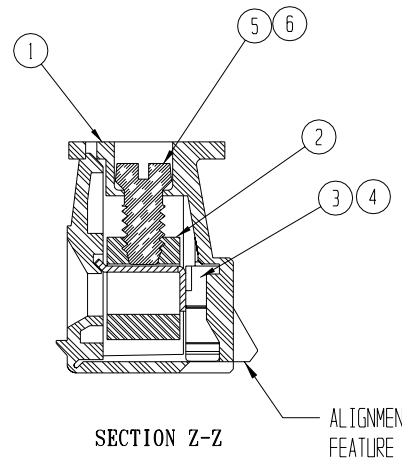
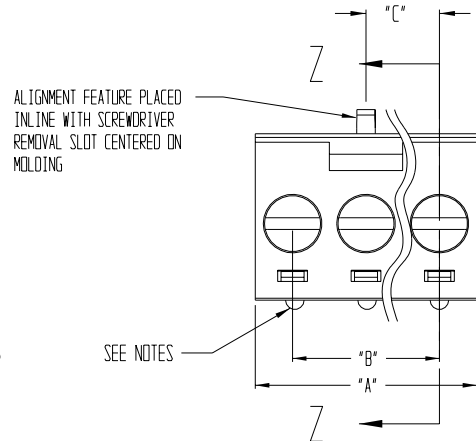
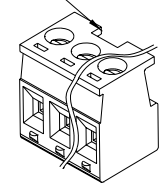

AUXILIARY VIEW SCALE 1:1

NOTES:

- MATERIAL: SEE TABLE
- FINISHES: SEE TABLE
- PRODUCT SPECIFICATION: NOT REQUIRED
- PACKAGING: NOT REQUIRED
- MATES WITH: 99 SERIES HEADER
- INCH DIMS ARE SHOWN IN BRACKETS [XXX]
- "XX" REFERS TO THE QTY. OF CIRCUITS
- SNAP FEATURES
 - 2 CIRCUIT: 2 SNAPS
 - 3-24 CIRCUIT: 3 SNAPS
 LOCATED ON ENDS AND ALIGNED WITH SCREWDRIVER REMOVAL SLOT

ITEM	QTY.	DESCRIPTION	MATERIAL	FINISH
6	XX	SCREW, M3 X 0.5 X 5.08 (-G30 OPTION)	PHOSPHOR BRONZE	TIN PLATE
5	XX	SCREW, M3 X 0.5 X 5.08 (STANDARD)	STEEL	ZINC CHROMATE
4	XX	TERMINAL (-G30 OPTION)	PHOSPHOR BRONZE	GOLD PLATE
3	XX	TERMINAL (STANDARD)	PHOSPHOR BRONZE	TIN PLATE
2	XX	PRESSURE CLAMP	BRASS	NICKEL PLATE
1	1	MOLDING	POLYAMIDE	BLACK

EC NO. RELEASED DRAWN: CLY CH K: APPR: A	DESCRIPTION MAJOR CRITICAL SPC S	GENERAL TOLERANCES: (UNLESS SPECIFIED)	SCALE 3:1 DESIGN UNITS <input type="checkbox"/> mm <input checked="" type="checkbox"/> INCH	THIRD ANGLE PROJECTION	PROJECT NO. - - DIMENSIONS: <input checked="" type="checkbox"/> mm <input type="checkbox"/> INCH <input type="checkbox"/> mm ONLY	SHEET REV REVISE ON CAD ONLY	
		4 PLACES ±.0015 3 PLACES ±.038 ±.005 2 PLACES ±.13 ±.01 1 PLACE ±.3	DRAWN BY & DATE C. YORK 08-12-03 CHECKED BY & DATE APPROVED BY & DATE	TITLE: SINGLE ROW EUROSTYLE PLUG ASSEMBLY 5.00mm [.197]	CAD FILENAME 9909XX01	MATERIAL NO. SEE CHART	DRAWING NO. SD-39990-001
DRAFT WHERE APPLICABLE MUST REMAIN WITHIN DIMENSIONS		THIS DRAWING CONTAINS INFORMATION THAT IS PROPRIETARY TO MOLEX INCORPORATED AND SHOULD NOT BE USED WITHOUT WRITTEN PERMISSION.					SITE B

Ⓐ REF. THIS DOC SUPERSEDES CADKEY DOC SD-39990-001 REV-A

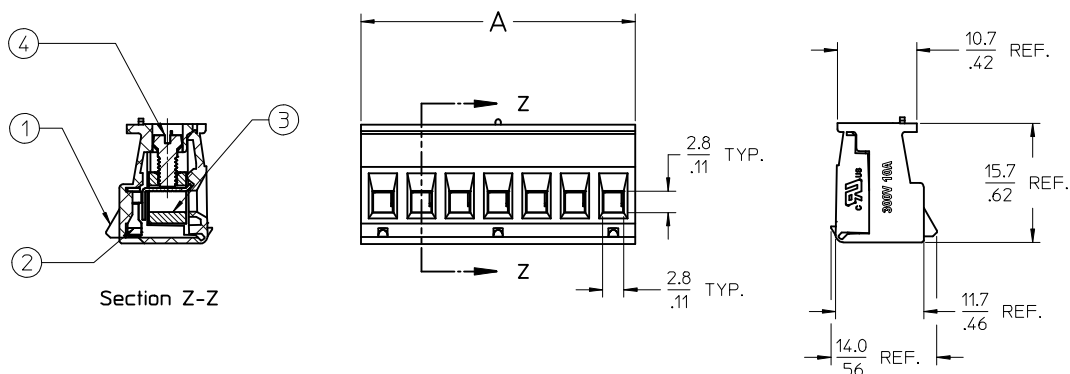
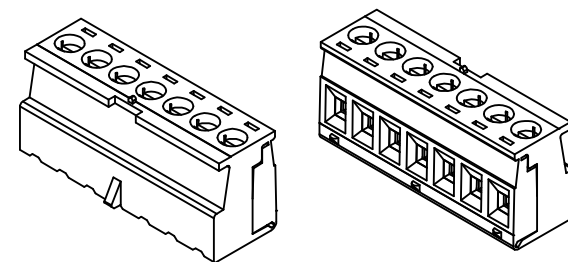
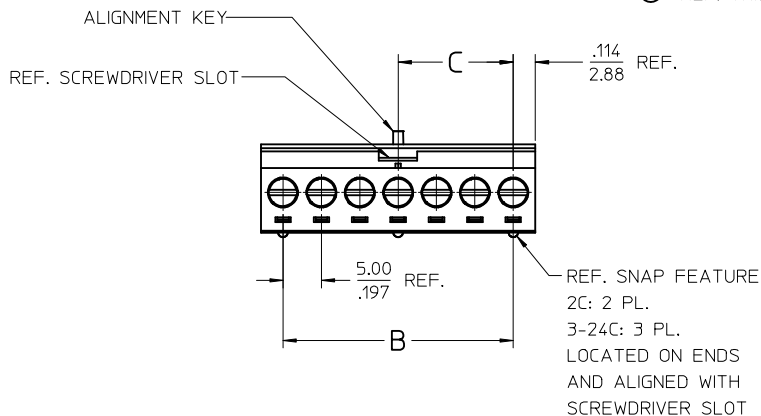

Section Z-Z

- NOTES:
1. MATERIAL: SEE TABLE
 2. FINISHES: SEE TABLE
 3. ELECTRICAL SPECIFICATIONS
VOLTAGE RATING: 300V
CURRENT RATING: 10 AMPS
 4. WIRE RANGE: 24-12AWG
 5. WIRE STRIP: 6mm (.25 IN)
 6. TIGHTENING TORQUE: .45NM (4 IN.LBS)
 7. XX REFERS TO NUMBER OF CIRCUITS

CIRCUITS	PART NO.	DIM-A mm ±0.25	DIM-A IN ±.010	DIM-B mm	DIM-B IN	DIM-C mm	DIM-C IN
2	399900302	10.77	.424	5.00	.197	5.00	.197
3	399900303	15.77	.621	10.00	.394	10.00	.394
4	399900304	20.77	.818	15.00	.591	10.00	.394
5	399900305	25.77	1.015	20.00	.787	10.00	.394
6	399900306	30.77	1.211	25.00	.984	15.00	.591
7	399900307	35.77	1.408	30.00	1.181	15.00	.591
8	399800308	40.77	1.605	35.00	1.378	20.00	.787
9	399900309	45.77	1.802	40.00	1.575	20.00	.787
10	399900310	50.77	1.999	45.00	1.772	25.00	.984
11	399900311	55.77	2.196	50.00	1.969	25.00	.984
12	399900312	60.77	2.393	55.00	2.165	30.00	1.181
13	399900313	65.77	2.589	60.00	2.362	30.00	1.181
14	399900314	70.77	2.786	65.00	2.559	35.00	1.378
15	399900315	75.77	2.983	70.00	2.756	35.00	1.378
16	399900316	80.77	3.180	75.00	2.953	40.00	1.575
17	399900317	85.77	3.377	80.00	3.150	40.00	1.575
18	399900318	90.77	3.574	85.00	3.346	45.00	1.772

ITEM	QTY.	DESCRIPTION	MATERIAL	FINISH
4	XX	SCREW, M3 X 0.5	STEEL	ZN, CLEAR CHROMATE
3	XX	CAGE	BRASS	NICKEL PLATED
2	XX	TERMINAL	Cu ALLOY	TIN PLATED
1	1	PLUG BODY (5.0mm)	NYLON	BLACK

REDRAWN: REMOVED GOLD OPT	QUALITY SYMBOLS
EC NO: IPGZ016-1388	▽=0
DRWRN: STONE 2016/04/15	▽=0
CHKD: MZILELSKI 2016/04/20	
APPR: BRUPERT 2016/04/22	
DESCRIPTION	
REV	

GENERAL TOLERANCES (UNLESS SPECIFIED)
mm INCH
4 PLACES ± --- ± ---
3 PLACES ± --- ± .005
2 PLACES ± 0.13 ± .01
1 PLACE ± 0.3 ± ---
0 PLACE ± --- ± ---
ANGULAR ± --- °
DRAFT WHERE APPLICABLE MUST REMAIN WITHIN DIMENSIONS

DIMENSION STYLE	SCALE	DESIGN UNITS
IN/MM	1:1	INCH
DRAWN BY	DATE	TITLE
RSTONE	2016/04/15	SINGLE ROW EURO PLUG
CHECKED BY	DATE	5.00MM (.197 IN) PITCH
MZILELSKI	2016/04/20	
APPROVED BY	DATE	
BRUPERT	2016/04/22	
MATERIAL NO.	DOCUMENT NO.	SHEET NO.
SEE TABLE	SD-39990-003	1 OF 1

THIRD ANGLE PROJECTION
molex
THIS DRAWING CONTAINS INFORMATION THAT IS PROPRIETARY TO MOLEX INCORPORATED AND SHOULD NOT BE USED WITHOUT WRITTEN PERMISSION