

Tous droits strictement réservés. Reproduction ou communication a des tiers interdite sous quelque forme que ce soit sans autorisation écrite du propriétaire. Propriété de c FCI. Droits de reproduction FCI.

All rights strictly reserved. Reproduction or issue to third parties in any form whatever is not permitted without written authority from the proprietor. Property of FCI. Copyright FCI.

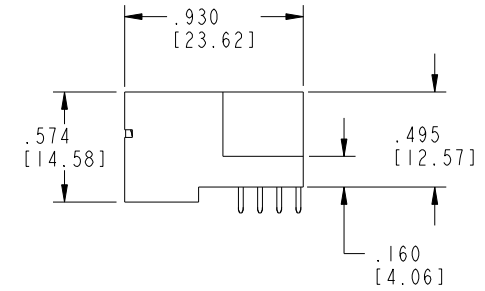
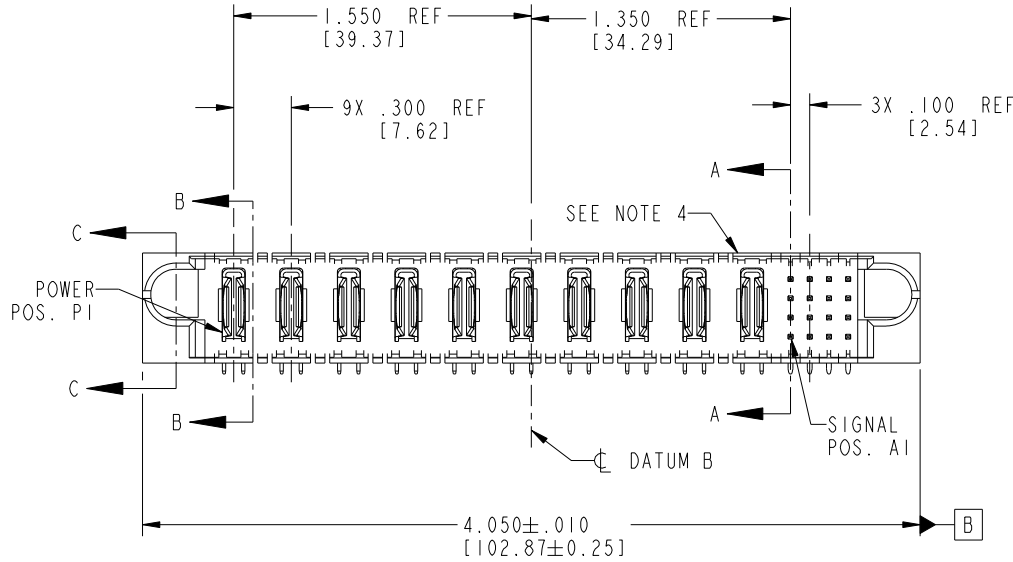
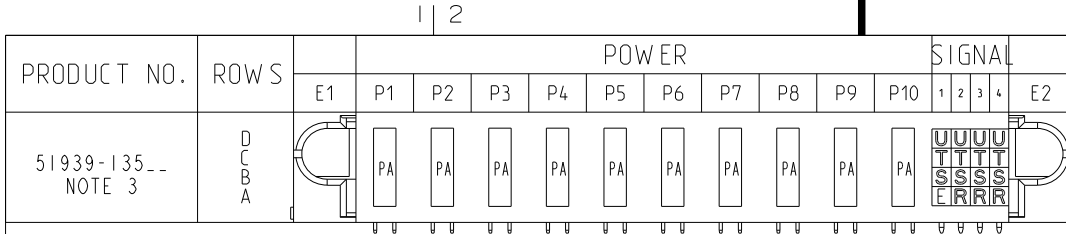

CODE	DIM "M" MATING LENGTH	CONTACT TYPE
E	.220 [5.59]	SIGNAL
R	.270 [6.86]	SIGNAL
S	.270 [6.86]	SIGNAL
T	.270 [6.86]	SIGNAL
U	.270 [6.86]	SIGNAL
PA	N/A [N/A]	POWER

mat'l code				SEE NOTE 2		tolerances unless otherwise specified		CUSTOMER		FCI	
ltr	ecn no.	dr	date	linear	.XX±.01/0.X±0.3	projection		COPY		www.fciconnect.com	
A	V04-0850	DAI	8/24/04		.XXX±.005/0.XX±0.13	INCH/MM		title		10P + 16S	
B	DG06-0013	RYAN	01/12/06	angles	.XXX±.0020/0.XXX±0.051	scale		product family		PwrBlade	
C	DG08-0266	W D	09/22/08		0°+2°	1:1		size		213	
sheet index		revision sheet		C	C	C	C	dwg no		sheet	
		1 2		3	4			A		1 of 4	
								51939-135			

Pro/E

PDM: Rev:C

STATUS: Released

Printed: Dec 20, 2010

Tous droits strictement réservés. Reproduction ou communication a des tiers interdite sous quelque forme que ce soit sans autorisation écrite du propriétaire. Propriété de c FCI. Droits de reproduction FCI.

All rights strictly reserved. Reproduction or issue to third parties in any form whatever is not permitted without written authority from the proprietor. Property of FCI. Copyright FCI.



PRODUCT NUMBER
51939-135__
NOTE 3

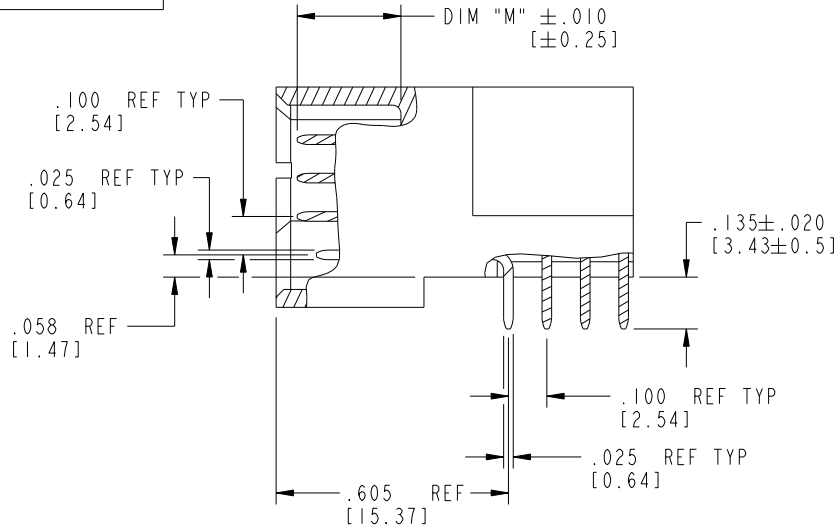

BROKEN-OUT SECTION A-A
SCALE 2:1

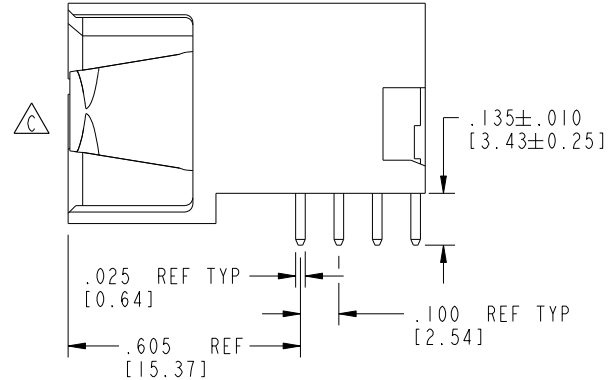

BROKEN-OUT SECTION B-B
SCALE 2:1

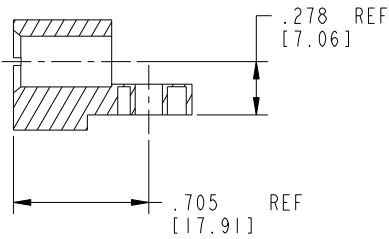

SECTION C-C

mat'l code		SEE NOTE 2		tolerances unless otherwise specified		CUSTOMER		 www.fciconnect.com	
ltr	ecn no.	dr	date	linear	.XX±.01/0.X±0.3	projection	title 10P + 16S		
C				angles	.XXX±.005/0.XX±0.13		RIGHT ANGLE SOLDER HEADER		
					.XXX±.0020/0.XXX±0.051		product family PwrBlade		code 213
				dr	D. INGRAM 08/24/04	INCH/MM	size dwg no		sheet 2 of 4
				enr	M. GRAY 08/23/04	scale 1:1	A 51939-135		
				chr	M. GRAY 08/23/04				
				appd	M. GRAY 08/23/04				
sheet index	revision sheet								

Pro/E

PDM: Rev: C

STAT: Released

Printed: Dec 20, 2010

Tous droits strictement réservés. Reproduction ou communication a des tiers interdite sous quelque forme que ce soit sans autorisation écrite du propriétaire. Propriété de c FCI. Droits de reproduction FCI.



All rights strictly reserved. Reproduction or issue to third parties in any form whatever is not permitted without written authority from the proprietor. Property of FCI. Copyright FCI.

PRODUCT NUMBER
51939-135--
NOTE 3

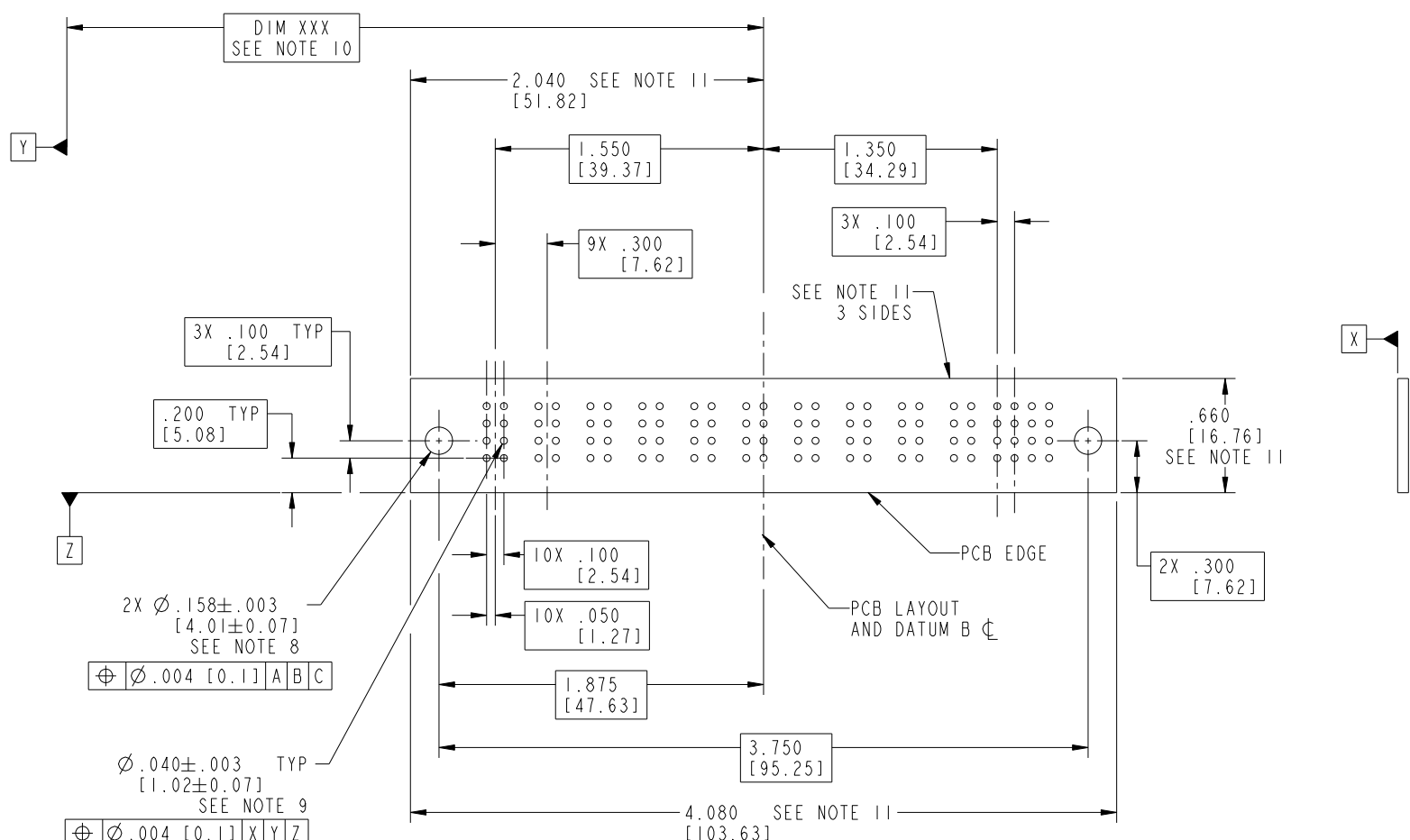

RECOMMENDED PCB LAYOUT

mat'l code		SEE NOTE 2		tolerances unless otherwise specified		CUSTOMER		 www.fciconnect.com	
ltr	ecn no.	dr	date	linear	.XX±.01/0.X±0.3	projection	title 10P + 16S		
C					.XXX±.005/0.XX±0.13	 INCH/MM	RIGHT ANGLE SOLDER HEADER		
				angles	.XXX±.002/0.XXX±0.051		product family	PwrBlade	code
				dr	D. INGRAM 08/24/04	scale	size	dwg no	213
				enrg	M. GRAY 08/23/04	1:1	A	51939-135	sheet
				chr	M. GRAY 08/23/04				3 of 4
				appd	M. GRAY 08/23/04				
sheet index	revision sheet								

cage code 28536

Pro/E

PDM: Rev: C

STATUS: Released

Printed: Dec 20, 2010

Tous droits strictement réservés. Reproduction ou communication a des tiers interdite sous quelque forme que ce soit sans autorisation écrite du propriétaire. Propriété de c FCI. Droits de reproduction FCI.



All rights strictly reserved. Reproduction or issue to third parties in any form whatever is not permitted without written authority from the proprietor. Property of FCI. Copyright FCI.

1 | 2

3

4

PRODUCT NUMBER
51939-135--
NOTE 3

NOTES:

1. DIMENSIONS AND TOLERANCES ARE IN ACCORDANCE WITH ASME Y14.5M, 1994 UNLESS OTHERWISE SPECIFIED.

CONNECTOR NOTES:

- ② HOUSING MATERIAL: UL 94 V-0 GLASS FILLED HIGH-TEMP THERMOPLASTIC
POWER CONTACT MATERIAL: COPPER ALLOY
SIGNAL PIN MATERIAL: COPPER ALLOY

△ 3. SEE ITEM 1 & 2 IN PRINT 10064183 FOR PLATING SPEC OF 51939-135 AND 51939-135LF RESPECTIVELY.

- ④ MANUFACTURER'S NAME, P/N, AND DATE CODE TO APPEAR ON THIS SURFACE.

5. PRODUCT SPECIFICATION GS-12-149.
APPLICATION SPECIFICATION BUS-20-067.

6. PACKAGED IN TRAYS.

PCB NOTES:

7. ALL HOLE DIAMETERS ARE FINISHED HOLE SIZE.

- ⑧ MOUNTING HOLES, WHERE APPLICABLE, ARE UNPLATED.

- ⑨ $\varnothing .0453 \pm .0010$ [1.151 ± 0.025] DRILLED HOLES PLATED WITH
.0003 [0.008] MIN SnPb OVER .001 [0.03]
TO .003 [0.08] Cu PLATING TO ACHIEVE
 $\varnothing .040 \pm .003$ [1.02 ± .07] HOLE.

- ⑩ "DIM XXX" TO BE DETERMINED BY THE CUSTOMER.

- ⑪ CONNECTOR KEEP-OUT ZONE.

12. A △ SYMBOL WILL BE NEXT TO ANY DIMENSION, VIEW, OR NOTE WHICH HAS BEEN MODIFIED WITH THE CURRENT DRAWING REVISION.

mat'l code				SEE NOTE 2		tolerances unless otherwise specified		CUSTOMER		FCI	
lfr	ecn no.	dr	date	linear	.XX±.01/0.X±0.3	projection		COPY		www.fciconnect.com	
C					.XXX±.005/0.XX±0.13	INCH/MM		title		10P + 16S	
				angles	.XXX±.0020/0.XXX±0.051	INCH/MM		RIGHT ANGLE SOLDER HEADER		product family	
				dr	0° ± 2°	scale		PwrBlade		code	
				enrg	D. INGRAM 08/24/04	1:1		size		213	
				chr	M. GRAY 08/24/04			A		sheet	
				appd	M. GRAY 08/23/04			51939-135		4 of 4	
sheet index		revision sheet									

A

A

B

B

1 | 2

Pro/E

PDM: Rev: C

STATUS: Released

Printed: Dec 20, 2010

cage code 28526

4