



浙江乐穗电子股份有限公司

ZHEJIANG YUESUI ELECTRON STOCK CO.,LTD.

产 品 规 格 书

PRODUCT SPECIFICATION

客户承认栏

产品名称： 扁平式振动马达

NAME： COIN TYPE VIBRATION MOTOR

产品型号 Model： B1034.FL45-00-015

日 期 Date： 2016-1-12

拟 制 DRAWN	王成美	校 对 CHECK	徐祥富	批 准 APPROVE	吴积忠
--------------	-----	--------------	-----	----------------	-----

MATERIAL or METHODS Specifications

ISSUE: 2
NUMBER:

MODEL:

ISSUE / 版本	REASON FOR CHANGE/ 更改原因	DR./ 拟制	APPR./ 审核	DATE/ 日期
1	RELEASE FOR DESIGN/产品设计	黄良芬	徐祥富	2005.5.28
2	ENRICH CONTENTS /完善内容	黄良芬	徐祥富	2006.6.10

MODEL:

TABLE OF CONTENTS/目录

- 1. OPERATING SCOPE/适用范围**
- 2. CONSTRUCTION-FORM /结构形式**
- 3. PERFORMANCE AND CHARACTERISTICS/性能和特性**
- 4. MEASURING CONDITIONS/测试条件**
- 5. APPEARANCE SPECIFICATION/外观性能要求**
- 6. RELIABILITY TEST /可靠性试验**
- 7. REQUIREMENTS/判断特性**
- 8. PACKAGE REQUIREMENTS/包装要求**
- 9. MATTERS TO BE PAID ATTENTION TO WHEN USING NOTOR/使用时注意事项**
- 10. OUTSIDE VIEW/外形图**

MATERIAL or METHODS Specifications

MODEL:

1. OPERATING SCOPE/适用范围

THIS SPECIFICATIONS APPLY TO $\Phi 10 \times 3.4 \text{T}$ STANDARD COIN TYPE VIBRATION MOTOR

该产品说明书适用于 $\Phi 10 \times 3.4 \text{T}$ 标准扁平马达。

2. CONSTRUCTION-FORM /结构形式

NO	ITEMS/项目	CONTENTS/内容
2-1	MOTOR CONSTRUCTION/ 马达结构	Dia 10mm Coin Type Vibration Motor 直径为 10mm 的扁平永磁马达
2-2	NUMBER OF PHASES/ 相数	SINGLE-PHASE (-CONNECTION)/ 单相
2-3	NUMBER OF MAGNET POLES/ 磁极极数	4-POLES 4 极
2-4	COIL CONSTRUCTION/ 线圈结构	FLAT CORELESS COIL/ 扁平型线圈
2-5	RECTIFYING METHOD/ 换向方式	COMMUTATOR/ 单平面扇形

3. PERFORMANCE AND CHARACTERISTICS/性能和特性

NO.	ITEMS/项目	SPECIFICATIONS/规定
3-1	RATED VOLTAGE / 额定电压	3.0V DC

MATERIAL or METHODS Specifications

ISSUE: 2

MODEL:

NUMBER:

3-2	OPERATING VOLTAGE / 电压使用范围	2.3 ~ 3.6V DC
3-3	STARTING VOLTAGE / 启动电压	2.0V DC
3-4	RATED CURRENT/ 额定电流	60mA (max)
3-5	RATED SPEED / 额定转速	13000±3000rpm /min
3-6	DIRECT CURRENT RESISTANCE/ 直流阻抗	33/65±20%Ω
3-7	OPERATING ENVIRONMENT/ 使用环境	-30 ~ 60°C 10 ~ 90%(RELATIVE HUMIDITY/相对湿度)
3-8	STORAGE ENVIRONMENT/ 贮存环境	-40 ~ 85°C 5 ~ 95%(RELATIVE HUMIDITY/相对湿度) (NO CONDENSATION OF MOISTURE/不凝露)
3-9	INSULATION RESISTANCE/ 绝缘强度	100V DC 10MΩ MIN.FROM HOUSING CASE TO TERMINAL CONTACTS, THE LEAKAGE CURRENT SHALL NOT EXCEED 1mA PEAK./从机身到端点在 100V 直流电时,最小为 10MΩ, 电流泄漏最多不超过 1mA。

MATERIAL or METHODS Specifications

ISSUE: 2

MODEL:

NUMBER:

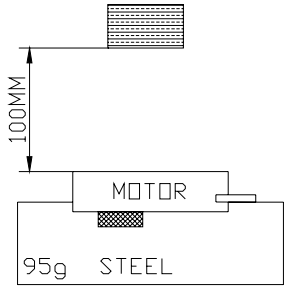
3-10	MECHANICAL NOISE/ 机械噪音	<p style="text-align: center;">50dB (A) (MAX) /AT RATED VOLTAGE AND RATED LOAD BACK GROUND NOISE : 30dB (A) (MAX)</p> <p style="text-align: center;">最大为 50dB (A) /额定电压及负荷下测试，背景噪音不超过 30 dB (A)</p> <div style="text-align: center;">  <p>The diagram shows a motor assembly on a rectangular base labeled '95g STEEL'. A vertical dimension line on the left indicates a height of '100MM' from the top surface of the base to the top of the motor housing. The motor housing is labeled 'MOTOR'.</p> </div>
------	---------------------------	--

4. MEASURING CONDITIONS/测试条件

NO	ITEMS/项目	SPECIFICATIONS/规格
4-1	TEMPERATURE/温度	25±2°C
4-2	RELATIVE HUMIDITY/相对湿度	45 ~ 85%

ALL DATA ARE BASED ON THE MEASURING CONDITIONS: TEMPERATURE, 20°C; HUMIDITY, 65%RH. IF ANY DISAGREEMENT OCCURS, SUCH TEST CONDITIONS ARE AVAILABLE: TEMPERATURE, 5 ~ 35°C; HUMIDITY, 45 ~ 85%RH.

所有数据的测试条件为：温度 20°C，相对湿度 65%RH。如果有任何不一致出现，在以下条件中测试也是可以的：温度 5 ~ 35°C，湿度(45 ~ 85%)RH。

5. APPEARANCE SPECIFICATION/外观性能要求

NO.	ITEMS/项目	SPECIFICATIONS/规定	CONDITION REMARK/条件、备注
5-1	CONFIGURATION/	AS SPECIFIED IN OUTLINE DRAWING/	

MATERIAL or METHODS Specifications

ISSUE: 2

MODEL:

NUMBER:

	外观尺寸	按外形图规定	
5-2	APPEARANCE/ 外观	<p>THERE SHALL BE NO EVIDENCE OF MECHANICAL DAMAGE, AND SHALL NOT HAVE INADEQUATE CORROSION AND SO ON./没有机械的损害痕迹, 并且也没有腐蚀痕迹, 等.</p>	<p>VISUAL EXAMINATION : (ALLOWABLE EXTENT IN BASED ON BOUNDARY SAMPLE)./目视检查(允许范围和限度见样品).</p>
5-3	WEIGHT/重量	0.9g(APPROX)	

6. RELIABILITY TEST /可靠性试验

NO	ITEMS/项目	SPECIFICATIONS/规定	REQUIREMENTS/判定特性
6-1	LIFE TEST/寿命试验	<p>VOLTAGE/电压 : 3.0V DC TEMPERATURE/温度 : 25°C±2°C HUMIDITY/湿度 : 65±5%RH TEST MODE/试验形式 : 2 SECS.ON (C.W)、 2 SECS. OFF TEST TIME/试验时间 : 20000 cycles</p>	<p>MEASUREMENT UNDER THE TEMPERATURE OF 25°C. AFTER THE TEST ,MOTOR SHALL BE APPROVED AS SPECIFIED IN ITEM7-1. 测试温度在 25°C。试验后, 应满足 7-1 项。</p>
6-2	SHOCK TEST/振动试验	<p>MOTOR WITHSTANDS DURATION OF 50M/S² WAVE FROM VELOCITY CHANGE OF 10 M/S² SHOCK FROM EACH OF X.Y.AXIS. 从 X, Y 轴输出的振动, 马达可承受从 10 M/S² 到 50M/S² 震级的转变。</p>	<p>AFTER THE TEST MOTORS SHALL BE APPROVED AS SPECIFIED IN ITEM 7-1. 试验后, 应满足 7-1 项要求。</p>
6-3	LOW TEMP EXPOSURE TEST/低温存放试验	<p>TEMPERATURE /温度 : -40°C±5°C TIME /时间 : 96 HOURS</p>	<p>ALL DATA ARE BASED ON THE MEASURING CONDITIONS: TEMPERATURE,25°C;HUMIDITY, 65%RH.AFTER 2HOURS EXPOSURE IN ORDINARY TEMPERATURE AND HUMIDITY , MOTORS SHALL BE APPROVED AS SPECIFIED IN ITEM 7-1.</p>
6-4	HIGH TEMP EXPOSURE TEST/高温存放试验	<p>TEMPERATURE /温度 : 70°C±5°C TIME/时间 : 96 HOURS</p>	

MATERIAL or METHODS Specifications

MODEL:

NUMBER:

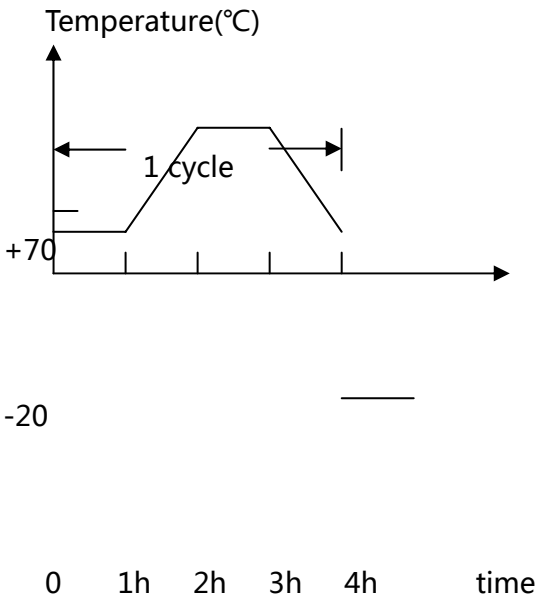
6-5	HUMIDITY EXPOSURE TEST/湿度存放试验	TEMPERATURE /温度 : 60±2°C HUMIDITY /湿度 : 90±5%RH TIME /时间 : 96 HOURS	所有测试在 25°C、相对湿度 65%中进行。在常温常湿中放置 2 小时后，测试应满足 7-1 项要求。
6-6	HEAT CYCLE TEST/温度冲击试验	 <p>Temperature(°C)</p> <p>+70</p> <p>-20</p> <p>0 1h 2h 3h 4h time</p> <p>Test cycle/试验循环周期数 : 15 cycles</p>	MEASUREMENT UNDER THE TEMPERATURE OF 25°C, AFTER 4 HOURS EXPOSURE IN ORDINARY TEMPERATURE AND HUMIDITY , MOTORS SHALL BE APPROVED AS SPECIFIED IN ITEM 7-1. 测试温度在 25°C。常温常湿中放置 4 小时后，测试应满足 7-1 项要求。

MATERIAL or METHODS Specifications

ISSUE: 2
NUMBER:

MODEL:

6-7	DROP TEST/ 跌落试验	<p>SET THE MOTOR TO THE APPROXIMATELY 100g(INCLUDING THE MOTOR)WEIGHT OF BLOCK DROP THE MOTOR ON THE CONCRETE FLOOR.</p> <p>电机放在大约 100g(包括电机)重的物体上自由落下到水泥地板上.</p> <p>HEIGHT/高度 : 1.5 m</p> <p>DIRECTION/方向 : ±X , ±Y , ±Z</p> <p>NUMBER OF TIMES/次数 : EACH 3 TIMES</p>	<p>AFTER THE TEST MOTORS SHALL BE APPROVED AS SPECIFIED IN ITEM 7-1.</p> <p>试验后, 应满足 7-1 项要求.</p>
-----	--------------------	--	---

7. REQUIREMENTS/判断特性

NO	ITEMS/项目	REQUIREMENTS/判定特性
7-1	TABLE A	<ol style="list-style-type: none"> 1. RATED SPEED /额定转速 : INITIAL DATA /初始值±30% (MAX) 2. RATED CURRENT /额定电流 : INITIAL DATA /初始值±30% (MAX) 3. STARTING VOLTAGE /启动电压 : 2.0V DC (MAX) 4. SHOULD NOT FAIL IN STARTING /正常启动 5. SHOULD NOT BE UNUSUAL MECHANICAL NOISE /无异常噪音

8. PACKAGE REQUIREMENTS/包装要求 (建议包装方式 , 厂家可根据本公司自己的包装方式进行)

CONTENT AND PROCESS/工作内容和程序

1.100 VIBRATORS IN EACH PLASTIC CAPSULE./每个泡沫盒里放 100 个马达。

MATERIAL or METHODS Specifications

ISSUE: 2

MODEL:

NUMBER:

2. EVERY 10 CAPSULES AS A GROUP, PUT A PLASTIC COVER ON THE GROUP AND WRAP IT IN TAPE./

每 10 个泡沫盒上盖一个泡沫盖板，用胶带捆做一捆。

3.PUT THE WRAPPED GROUP INTO A PLASTIC BAG AND WRAP THE BAG./捆好后装入塑料袋内用胶带

绑好。

4.EVERY 8 BAGS ARE PUT INTO AN OUTER CASE WITH A SIZE OF $495 \times 315 \times 445$ BY THE WAYS

STIPULATED AS THE DRAWING./每 8 袋泡沫盒按图中的叠放方式放入一个外包装箱 ($495 \times 315 \times 445$)。

5.QUANTITY AND BATCH NUMBER ARE WRITTEN ON THE SURFACE OF THE OUTER CASE./数量、生

产批号均写在外包装箱上。

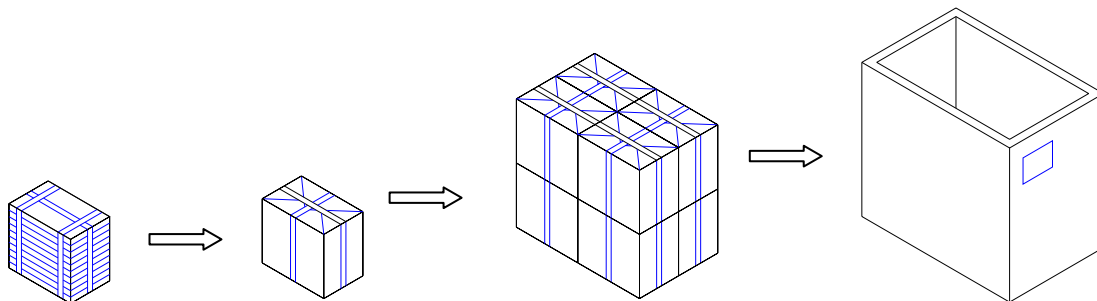

9. MATTERS TO BE PAID ATTENTION TO WHEN USING NOTOR/使用时注意事项

1、 PLEASE LAY THE NOTORS CAREFULLY IN TRANSPORTATION TO AVOID ANY SERIOUS DAMAGE TO

THE MOTOR BODY OR ITS ELECTRIC FUNCTION BECAUSE OF COLLISION./电机在运输过程中应小心

轻放，避免严重碰撞敲击引起的电机机身和性能受损。

MATERIAL or METHODS

Specifications

-
- 2、 PLEASE USE THE MOTOR ACCORDING TO THE INSTRUCTION OF THIS PRODUCT SPECIFICATION, OR ELSE, IT WILL BE BAD FOR MOTOR' S LIFE./必须按照规格书的标准使用，否则会影响电机寿命。
- 3、 MAKE ARRANGEMENT TO LIMIT THE STORAGE PERIOD TO 6 MONTHS OR LESS. PLEASE FO NOT STORE MOTOR IN HIGH TEMPERATURE, LOW TEMPERATUEE. HIGH HUMIDITY ENVIRONMENT. CONDENSATION OF ATMOSPHERE MUST BE AVOIDED IN MOTER USAGE OR OPENING THE PACKAGING OF THE MOTOR./请在 6 个月内使用，请不要在高温、低温、高湿环境下存储。在使用和打开马达外包装时请避免水气凝结。
- 4、 FOR PROPER OPERATION, STORAGE AND OPERATING ENVIRONMENT MUST NOT CONTAIN CORROSIVE GASES. FOR EXAMPLE H2S. SO2. NO2. CL2. ETC. IN ADDITION STORAGE ENVIRONMENT MUST NOT HAVE MATERIALS THAT EMIT CORROSIVE GASES ESPECIALLY FROM SILICON, CYANIC. FORMALIN AND PHENOL GROUP. IN THE MECHANISM OR THE SET. EXISTENCE OF CORROSIVE GASES MAY CAUSE NO ROTATION IN MOTOR./马达应适当的操作、储存和运转环境中均不可存在腐蚀性气体。例如：H2S、SO2、NO2、CL2 等。另外存储环境中不可有诸如硅、氰、甲醛水和苯酚等能放射出腐蚀性气体的物质，在电机的机械构造或装置中，如果存在腐蚀性气体，那么这会引起马达不运转。
- 5、 DUE ATTENTION MUST BE PAID TO THE HANDLING AND WORKING ENVIRONMENTS BECAUSE SUCH OBJECTS AS IRON POWDER IF ATTRACTED BY THE MOTOR MAGNENT,WILL CAUSE NOISE,CHARACTERISTIC DETERIORATION THUS REDUCING THE TELIABILITY./ 注意处理马达的工作环境，避免含铁质等物体被马达吸住，否则马达将会产生噪声，性能会降低，从而减少产品可靠性。

B1034.FL45-00-015

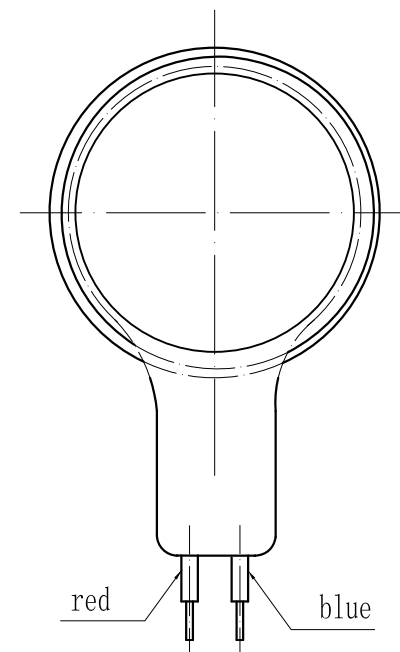
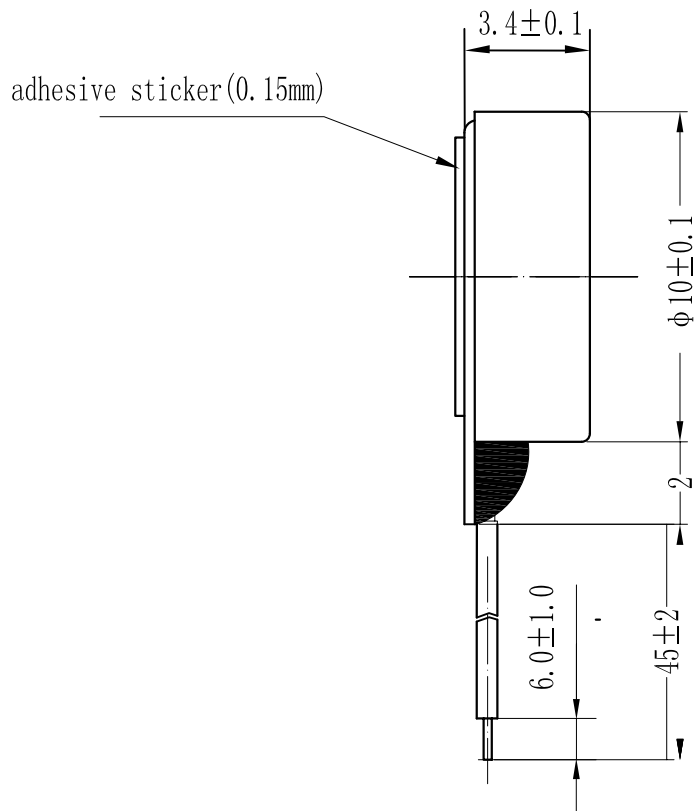

Technical requirement

1. Rated Voltage: 3.0V
2. Rated Current: 60mA Max
3. Rated Speed: 13000 ± 3000rpm
4. Direct Current Resistance: 33/65 Ω (± 20%)
5. Starting Voltage: 2.0V Max
6. Wire Spec: AWG32 UL1571

Borrow (pass) with a registration

Scanning

Scanning and Check

Old Outline Drawing Number

Outline Drawing Number

Signature

Date

Mark	Revise	Reversion	Signature	Date
Design			Standardize	
Check			Approve	
Approve				
Technology			Date	

**COIN TYPE
VIBRATION MOTOR**

Pattern Mark		Weight	Proportion
Total pages		Page	

Zhejiang Yuesui Electron Stock Co.,Ltd

Specification

B1034.FL45-00-015