



ON Semiconductor®

<http://onsemi.com>

# LV8760T

Bi-CMOS LSI

## Forward/Reverse H-bridge Driver

### Overview

The LV8760T is an H-bridge driver that can control four operation modes (forward, reverse, brake, and standby) of a motor. The low on-resistance, zero standby current, highly efficient IC is optimal for use in driving brushed DC motors for office equipment.

### Features

- Forward/reverse H-bridge motor driver: 1 channel
- Built-in current limiter circuit
- Built-in thermal protection circuit
- Built-in short-circuit protection function

### Specifications

**Absolute Maximum Ratings** at  $T_a = 25^\circ\text{C}$

Parameter	Symbol	Conditions	Ratings	Unit
Supply voltage	$V_M$ max		38	V
	$V_{CC}$ max		6	V
Output peak current	$I_O$ peak	$t_w \leq 20\text{ms}$ , duty 5%	4	A
Output continuous current	$I_O$ max		3	A
Logic input voltage	$V_{IN}$		-0.3 to $V_{CC}+0.3$	V
Allowable power dissipation	$P_d$ max	Mounted on a specified board. *	3.3	W
Operating temperature	$T_{opr}$		-20 to +85	$^\circ\text{C}$
Storage temperature	$T_{stg}$		-55 to +150	$^\circ\text{C}$

\* Specified circuit board : 90mm×90mm×1.6mm, glass epoxy 2-layer board (2S0P), with backside mounting.

Stresses exceeding Maximum Ratings may damage the device. Maximum Ratings are stress ratings only. Functional operation above the Recommended Operating Conditions is not implied. Extended exposure to stresses above the Recommended Operating Conditions may affect device reliability.

# LV8760T

## Allowable Operating Ratings at Ta = 25°C

Parameter	Symbol	Conditions	Ratings	Unit
Supply voltage range	VM		9 to 35	V
	V <sub>CC</sub>		3 to 5.5	V
VREF input voltage	VREF		0 to V <sub>CC</sub> -1.8	V
Logic input voltage	V <sub>IN</sub>		0 to V <sub>CC</sub>	V

## Electrical Characteristics at Ta = 25°C, VM = 24V, V<sub>CC</sub> = 5V, VREF = 1.5V

Parameter	Symbol	Conditions	Ratings			Unit
			min	typ	max	
<b>General</b>						
Standby mode current drain 1	IMst	PS = "L"			1	μA
Standby mode current drain 2	I <sub>CCst</sub>	PS = "L"			1	μA
Operating mode current drain 1	IM	PS = "H", IN1 = "H", with no load		1	1.3	mA
Operating mode current drain 2	I <sub>CC</sub>	PS = "H", IN1 = "H", with no load		3	4	mA
VREG output voltage	VREG	I <sub>O</sub> = -1mA	4.75	5	5.25	V
V <sub>CC</sub> low-voltage cutoff voltage	V <sub>th</sub> V <sub>CC</sub>		2.5	2.7	2.9	V
Low-voltage hysteresis voltage	V <sub>th</sub> HIS		120	150	180	mV
Thermal shutdown temperature	TSD	Design guarantee *	155	170	185	°C
Thermal hysteresis width	ΔTSD	Design guarantee *		40		°C
<b>Output block</b>						
Output on resistance	R <sub>on1</sub>	I <sub>O</sub> = 3A, sink side		0.2	0.25	Ω
	R <sub>on2</sub>	I <sub>O</sub> = -3A, source side		0.32	0.40	Ω
Output leakage current	I <sub>Oleak</sub>	V <sub>O</sub> = 35V			50	μA
Rising time	t <sub>r</sub>	10% to 90%		200	500	ns
Falling time	t <sub>f</sub>	90% to 10%		200	500	ns
Input output delay time	t <sub>pLH</sub>	IN1 or IN2 to OUTA or OUTB (L → H)		550	700	ns
	t <sub>pHL</sub>	IN1 or IN2 to OUTA or OUTB (H → L)		550	700	ns
<b>Charge pump block</b>						
Step-up voltage	VGH	VM = 24V	28.0	28.7	29.8	V
Rising time	t <sub>ONG</sub>	VG = 0.1μF		250	500	μs
Oscillation frequency	F <sub>cp</sub>		115	140	165	kHz
<b>Control system input block</b>						
Logic pin input current 1	I <sub>INL</sub>	V <sub>IN</sub> = 0.8V adaptive pin : PS	5.6	8	10.4	μA
	I <sub>INH</sub>	V <sub>IN</sub> = 5V adaptive pin : PS	56	80	104	μA
Logic pin input current 2	I <sub>INL</sub>	V <sub>IN</sub> = 0.8V adaptive pin : IN1, IN2	5.6	8	10.4	μA
	I <sub>INH</sub>	V <sub>IN</sub> = 5V adaptive pin : IN1, IN2	35	50	65	μA
Logic pin input H-level voltage	V <sub>INH</sub>	adaptive pin : PS, IN1, IN2	2.0			V
Logic pin input L-level voltage	V <sub>INL</sub>	adaptive pin : PS, IN1, IN2			0.8	V
<b>Current limiter block</b>						
VREF input current	IREF		-0.5			μA
Current limit comparator threshold voltage	V <sub>thlim</sub>	VREF = 1.5V	0.285	0.3	0.315	V
Blanking time	T <sub>blk</sub>		1.6	2.0	2.4	μs
<b>Short-circuit protection block</b>						
SCP pin charge current	I <sub>scp</sub>	SCP = 0V	3.5	5	6.5	μA
Comparator threshold voltage	V <sub>thscp</sub>		0.8	1	1.2	V

\* Design guarantee value and no measurement is made.

# LV8760T

## Package Dimensions

unit : mm (typ)  
3279

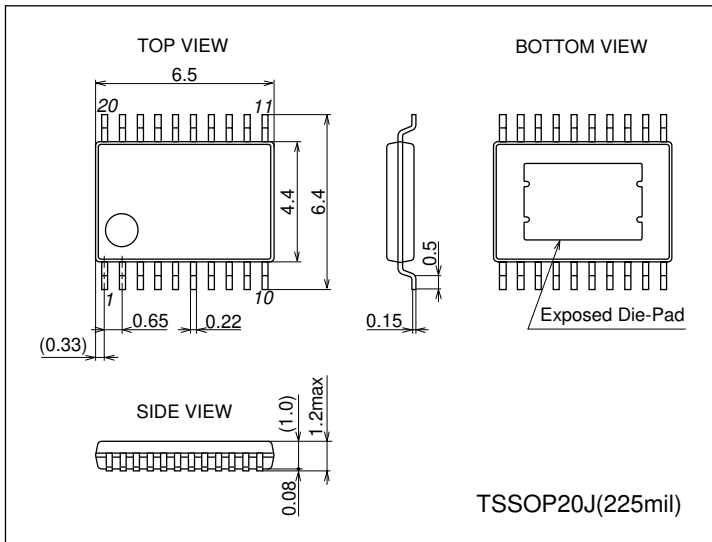

## Pin Assignment

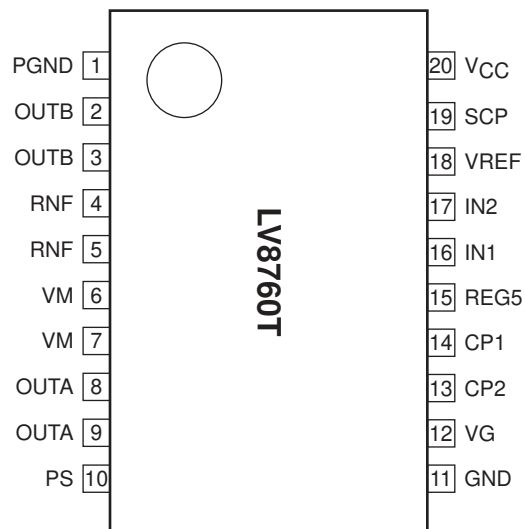

# LV8760T

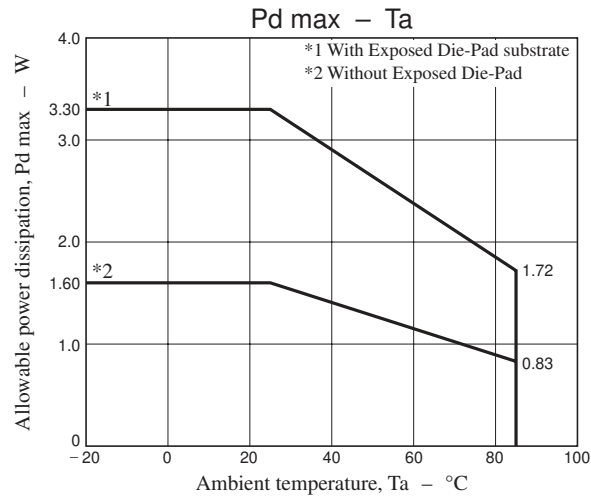

## Substrate Specifications (Substrate recommended for operation of LV8760T)

Size : 90mm × 90mm × 1.6mm (two-layer substrate [2S0P])  
Material : Glass epoxy  
Copper wiring density : L1 = 95% / L2 = 95%

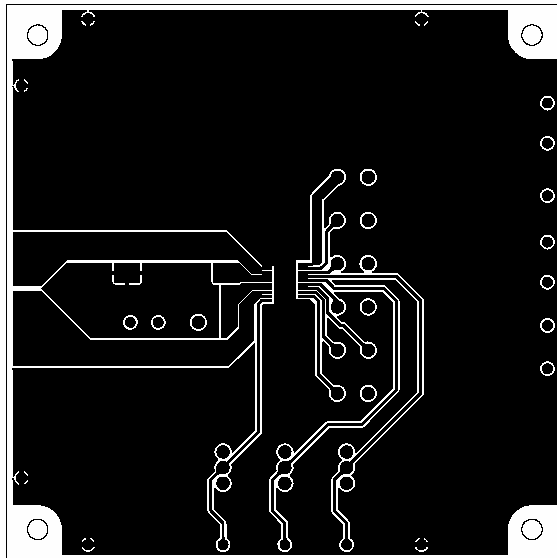

L1 : Copper wiring pattern diagram

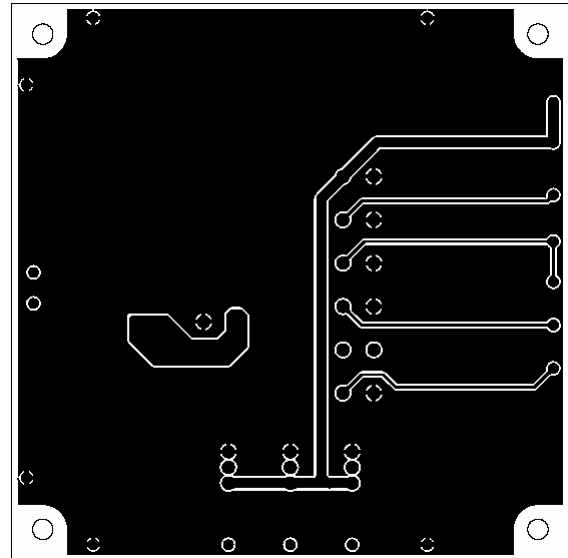

L2 : Copper wiring pattern diagram

## Cautions

- 1) The data for the case with the Exposed Die-Pad substrate mounted shows the values when 90% or more of the Exposed Die-Pad is wet.
- 2) For the set design, employ the derating design with sufficient margin.  
Stresses to be derated include the voltage, current, junction temperature, power loss, and mechanical stresses such as vibration, impact, and tension.  
Accordingly, the design must ensure these stresses to be as low or small as possible.  
The guideline for ordinary derating is shown below :
  - (1)Maximum value 80% or less for the voltage rating
  - (2)Maximum value 80% or less for the current rating
  - (3)Maximum value 80% or less for the temperature rating
- 3) After the set design, be sure to verify the design with the actual product.  
Confirm the solder joint state and verify also the reliability of solder joint for the Exposed Die-Pad, etc.  
Any void or deterioration, if observed in the solder joint of these parts, causes deteriorated thermal conduction, possibly resulting in thermal destruction of IC.

Block Diagram

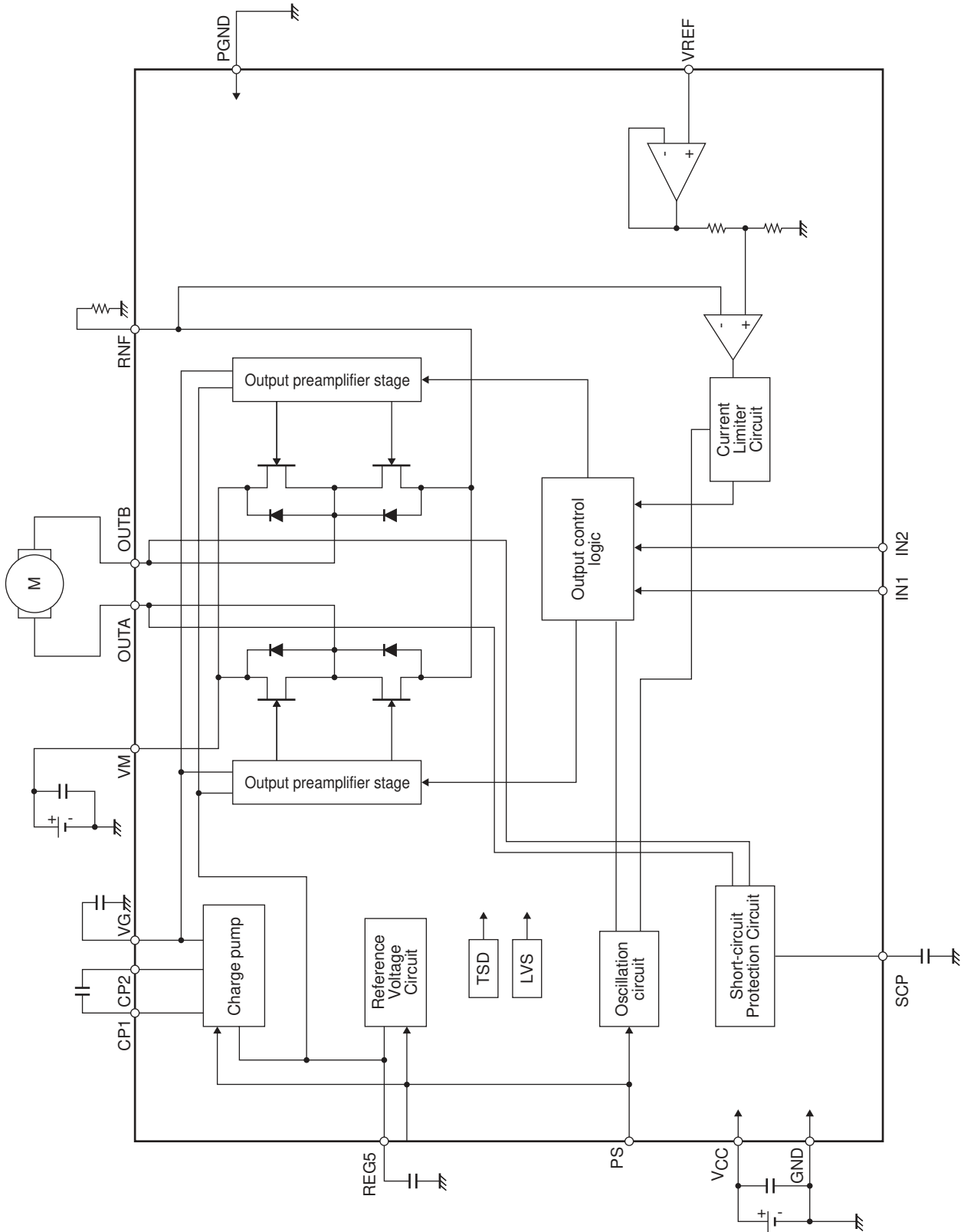

# LV8760T

## Pin Functions

Pin No.	Pin Name	Pin Function	Equivalent Circuit
16 17	IN1 IN2	Output control signal input pin 1. Output control signal input pin 2.	
10	PS	Power save signal input pin.	
18	VREF	Reference voltage input pin for output current limit setting.	
19	SCP	Short-circuit protection circuit, detection time setting capacitor connection pin.	
20	V <sub>CC</sub>	Power supply connection pin for control block.	

Continued on next page.

# LV8760T

Continued from preceding page.

Pin No.	Pin Name	Pin Function	Equivalent Circuit
6, 7 8, 9 4, 5 2, 3 1	VM OUTA RNF OUTB PGND	Motor power-supply connection pin. OUTA output pin. Current sense resistor connection pin. OUTB output pin. Power ground.	
14 13 12	CP1 CP2 VG	Charge pump capacitor connection pin. Charge pump capacitor connection pin. Charge pump capacitor connection pin.	
15	REG5	Internal reference voltage output pin.	
11	GND	Ground.	

# LV8760T

## DC Motor Driver

### 1.DCM output control logic

Control Input			Output		Mode
PS	IN1	IN2	OUTA	OUTB	
L	*	*	OFF	OFF	Standby
H	L	L	OFF	OFF	Output OFF
H	H	L	H	L	CW (forward)
H	L	H	L	H	CCW (reverse)
H	H	H	L	L	Brake

### 2.Current limit control timing chart

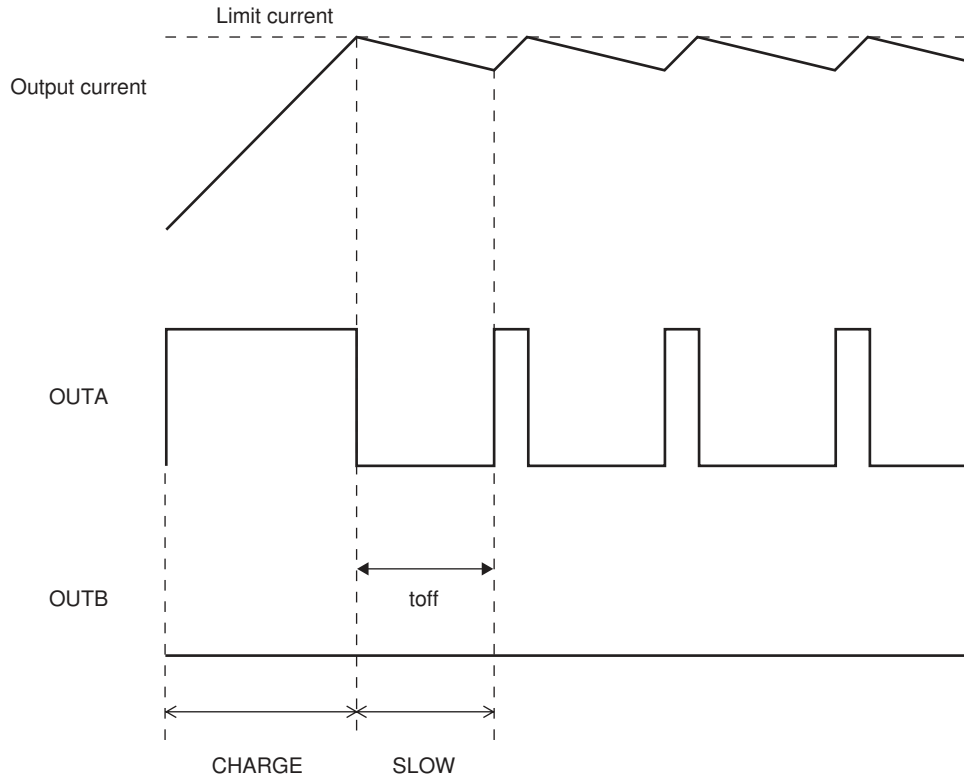

Braking operation time in current limit mode can be set by connecting a capacitor between SCP and GND pins. This setting is the same as the time setting required to turn off the outputs when an output short-circuit occurs as explained in the section entitled "Output Short-circuit Protection Function." See "Output Short-circuit Protection Function," for the setting procedure.

### 3.Setting the current limit value

The current limit value of the DCM driver is determined by the VREF voltage and the resistance (RNF) connected across the RNF and GND pins using the following formula :

$$I_{\text{limit}} [\text{A}] = (\text{VREF} [\text{V}] / 5) / \text{RNF} [\Omega]$$

Assuming VREF = 1.5V, RNF = 0.2Ω, the current limit is :

$$I_{\text{limit}} = 1.5\text{V} / 5 / 0.2\Omega = 1.5\text{A}$$



## Output short-circuit protection function

The LV8760T incorporates an output short-circuit protection circuit. It turns the outputs off to prevent destruction of the IC if a problem such as an output pin being shorted to the motor power supply or ground occurs.

### 1. Protection function operation (Latch method)

The short-circuit protection circuit is activated when it detects the output short-circuit state. If the short-circuit state continues for the internally preset period ( $\approx 4\mu\text{s}$ ), the protection circuit turns off the output from which the short-circuit state has been detected. Then it turns the output on again after a lapse of the timer latch time described later. If the short-circuit state is still detected, it changes all the outputs to the standby mode and retains the state. The latched state is released by setting the PS to L.

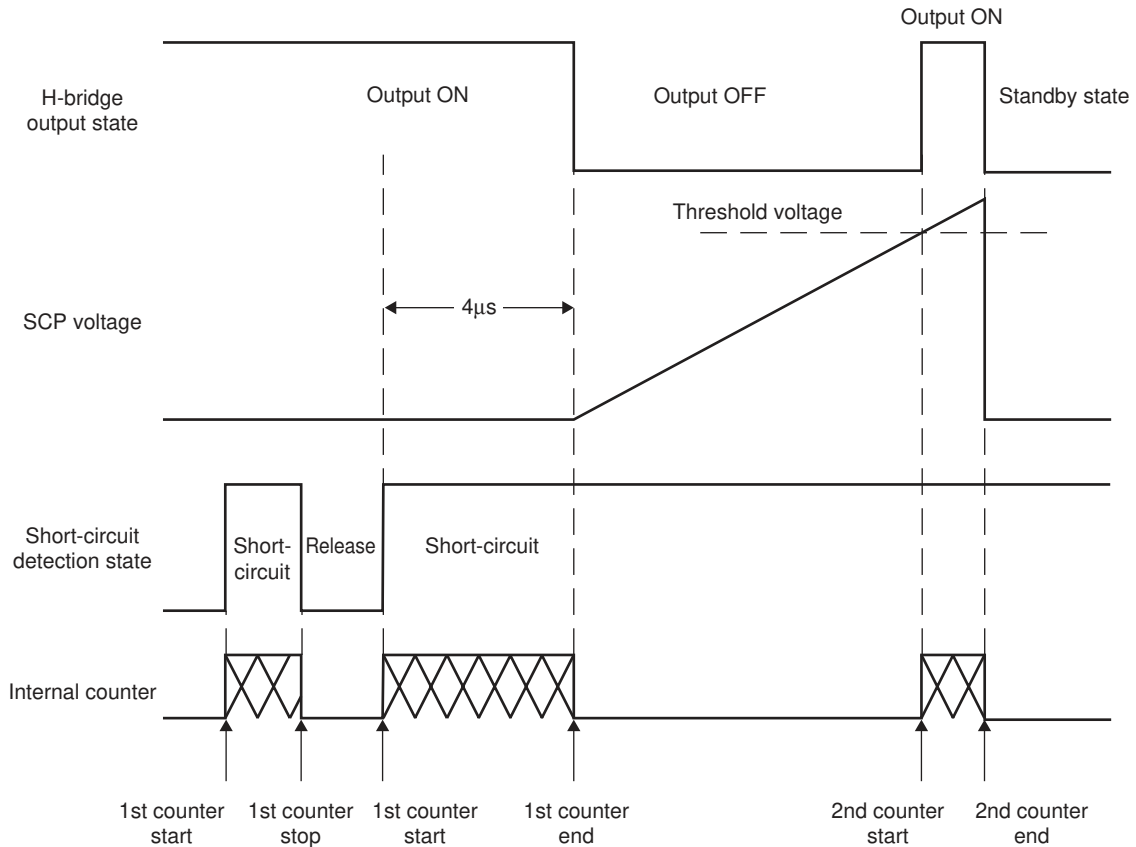

### 2. How to set the SCP pin constant (timer latch-up setting)

The user can set the time at which the outputs are turned off when a short-circuit occurs by connecting a capacitor across the SCP and GND pins. The value of the capacitor can be determined by the following formula :

Timer latch-up :  $T_{ocp}$

$$T_{ocp} \approx C \times V/I \text{ [s]}$$

V : Comparator threshold voltage (1V typical)

I : SCP charge current ( $5\mu\text{A}$  typical)

When a capacitor with a capacitance of  $50\text{pF}$  is connected across the SCP and GND pins, for example,  $T_{scp}$  is calculated as follows :

$$T_{scp} = 50\text{pF} \times 1\text{V}/5\mu\text{A} = 10\mu\text{s}$$

## Application Circuit Example

(When you use the current limit function)

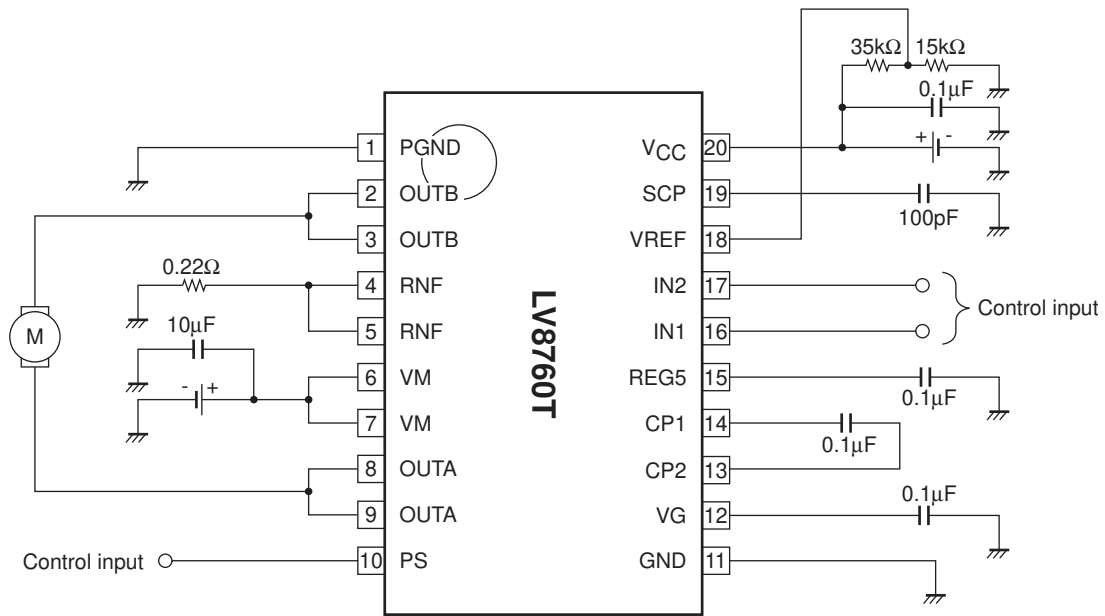

### Setting the current limit value

When  $V_{CC} = 5V$ ,

$V_{ref} = 1.5V$

$I_{limit} = V_{ref}/5/RNF$

$= 1.5V/5/0.22\Omega = 1.36A$

### Setting the current limit regeneration time and short-circuit detection time

$T_{scp} \approx C \times V/I$

$= 100pF \times 1V/5\mu A$

$= 20\mu s$

# LV8760T

(When you do not use the current limit function)

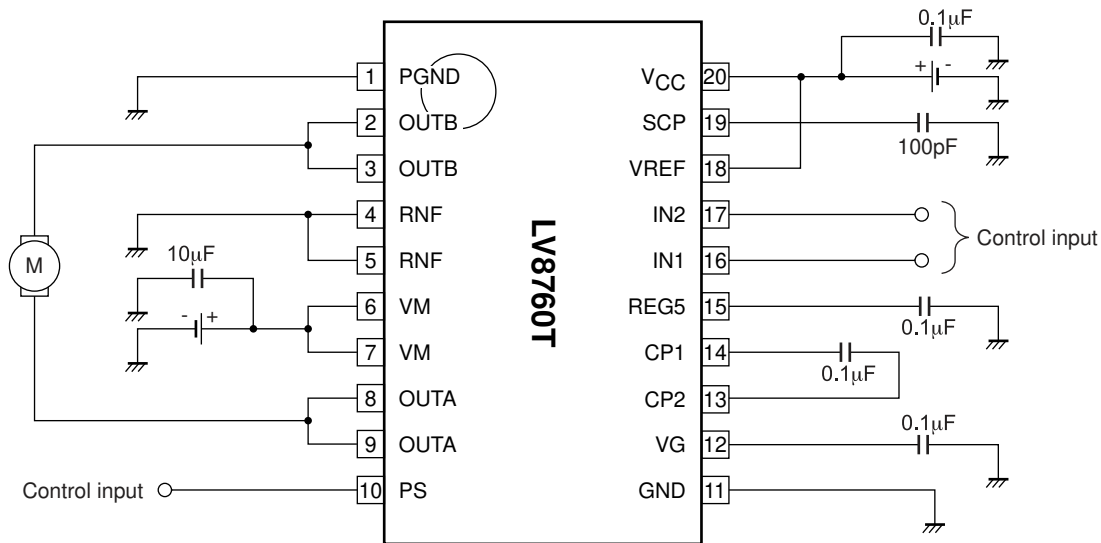

Setting at short-circuit state detection time

$$\begin{aligned}
 T_{SCP} &\approx C \cdot V / I \\
 &= 100\text{pF} \cdot 1\text{V} / 5\mu\text{A} \\
 &= 20\mu\text{s}
 \end{aligned}$$

\*Do the following processing when you do not use the current limit function.

- It is short between RNF-GND.
- The terminal VREF is hung on suitable potential of VCC or less.

ON Semiconductor and the ON logo are registered trademarks of Semiconductor Components Industries, LLC (SCILLC). SCILLC owns the rights to a number of patents, trademarks, copyrights, trade secrets, and other intellectual property. A listing of SCILLC's product/patent coverage may be accessed at [www.onsemi.com/site/pdf/Patent-Marking.pdf](http://www.onsemi.com/site/pdf/Patent-Marking.pdf). SCILLC reserves the right to make changes without further notice to any products herein. SCILLC makes no warranty, representation or guarantee regarding the suitability of its products for any particular purpose, nor does SCILLC assume any liability arising out of the application or use of any product or circuit, and specifically disclaims any and all liability, including without limitation special, consequential or incidental damages. "Typical" parameters which may be provided in SCILLC data sheets and/or specifications can and do vary in different applications and actual performance may vary over time. All operating parameters, including "Typicals" must be validated for each customer application by customer's technical experts. SCILLC does not convey any license under its patent rights nor the rights of others. SCILLC products are not designed, intended, or authorized for use as components in systems intended for surgical implant into the body, or other applications intended to support or sustain life, or for any other application in which the failure of the SCILLC product could create a situation where personal injury or death may occur. Should Buyer purchase or use SCILLC products for any such unintended or unauthorized application, Buyer shall indemnify and hold SCILLC and its officers, employees, subsidiaries, affiliates, and distributors harmless against all claims, costs, damages, and expenses, and reasonable attorney fees arising out of, directly or indirectly, any claim of personal injury or death associated with such unintended or unauthorized use, even if such claim alleges that SCILLC was negligent regarding the design or manufacture of the part. SCILLC is an Equal Opportunity/Affirmative Action Employer. This literature is subject to all applicable copyright laws and is not for resale in any manner.