

REVISIONS				
REV.	DESCRIPTION		DATE	APPROVED
A	INITIAL RELEASE	NPR 8471	90-7-11	<i>Munch</i>
B	REV'D P1 & P3	ECO 8530	90-11-2	<i>Munch</i>
C	REV'D P1 & P3	ECO 9003	93-6-1	<i>Rt</i>
D	REV'D P1, P2 & P6	NPR 9074	93-8-16	<i>Rt</i>

SALES DRAWING

REV. STATUS OF SHEETS							P.O. BOX 4422 Santa Barbara, CA 93140-4422	
REV.	D	B	C	A	A		TITLE HIGH VOLTAGE VACUUM RELAY, LATCHING	
SHEET	1	2	3	4	5			
REV.	A					DWG. NO. K40P SERIES		
SHEET	6							
PRED. BY	TANNER		90-07-10			FSCM NO. 18741	SHEET 1	CF 6
CHKD. BY	<i>Munch</i>		9-7-11					
ENG. APRVL.	<i>Kohlman</i>		7/10/93					

SPECIFICATIONS:

CONTACT ARRANGEMENT.....	SPST
FORM.....	LATCHING
TEST VOLTAGE (dc OR 60 Hz, kV PEAK).....	6
RATED OPERATING VOLTAGE (kV PEAK)	
dc OR 60 Hz.....	5
2.5 MHz.....	4.5
16 MHz.....	3.5
32 MHz.....	2.8
CONTINUOUS CURRENT CARRY, MAX. (A RMS)	
dc OR 60 Hz.....	35
2.5 MHz.....	25
16 MHz.....	14
32 MHz.....	8
COIL HI-POT (V RMS, 60 Hz).....	500
CONTACT CAPACITANCE (pF)	
BETWEEN OPEN CONTACTS.....	1.2
OPEN CONTACTS TO GROUND.....	1.2
CONTACT RESISTANCE, MAX. (OHMS).....	0.020
OPERATE TIME, MAX. (ms).....	1
SHOCK, 11 ms 1/2 SINE (PEAK G's).....	50
VIBRATION, 30 G's PEAK (Hz).....	55-2000
OPERATING TEMPERATURE RANGE (°C).....	-55 TO +125
MECHANICAL LIFE (OPERATIONS X 10 ⁶).....	40
WEIGHT, MAXIMUM (oz).....	1

RELAY PART NUMBER				
Outline Per FIG. 1 →		K40P334		
Outline Per FIG. 2 →		K40P332		
Outline Per FIG. 3 →		K40P364		
COIL VOLTAGE, NOMINAL		26.5*		
PICK-UP VOLTAGE, MAX. Vdc)		16		
COIL RESISTANCE (OHMS ±10%)		80		

NOTES: RATINGS LISTED ARE FOR 25°C SEA LEVEL CONDITIONS.
 RELAY FLANGE MUST BE GROUNDED.
 *NOT FOR CONTINUOUS DUTY.
 1ms MINIMUM ENERGIZATION TIME.
 1s MAXIMUM ENERGIZATION TIME
 10% MAXIMUM DUTY CYCLE

DIMENSIONS IN INCHES (DIMENSIONS IN PARENTHESES ARE IN MILLIMETERS) TOLERANCES EXCEPT AS NOTED .xx = ± .03 .xxx = ± .010 ∠ x° = ± 2° DO NOT SCALE DWG.			P.O. BOX 4422 Santa Barbara, CA 93140-4422	
	K40P SERIES			
	CAGE CODE <div style="text-align: center; font-size: 18pt;">18741</div>	SCALE <div style="text-align: center; font-size: 18pt;">NONE</div>	SHEET <div style="text-align: center; font-size: 18pt;">2</div>	

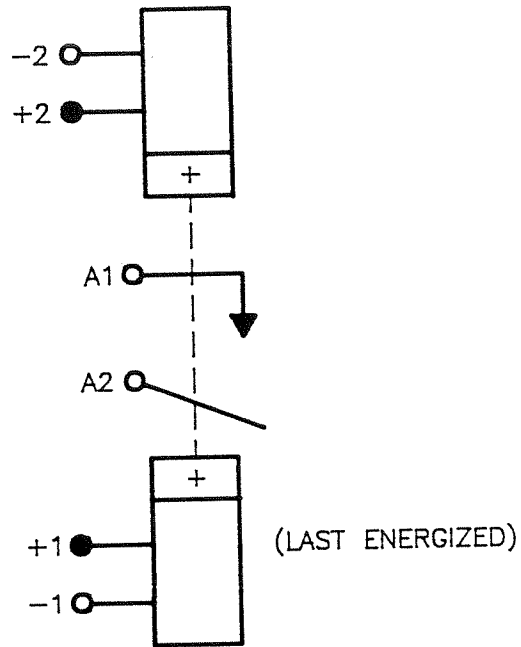

SCHEMATIC

DIMENSIONS IN INCHES
(DIMENSIONS IN PARENTHESES ARE IN
MILLIMETERS)

TOLERANCES EXCEPT AS NOTED

.xx = ± .03

.xxx = ± .010

\angle x° = ± 2°

DO NOT SCALE DWG.

Kilovac[®]
Corporation

P.O. BOX 4422
Santa Barbara, CA 93140-4422

K40P SERIES

CAGE CODE
18741

SCALE
NONE

SHEET
3

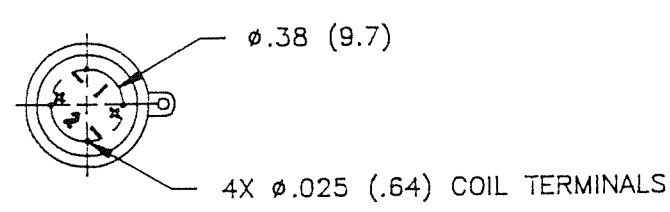
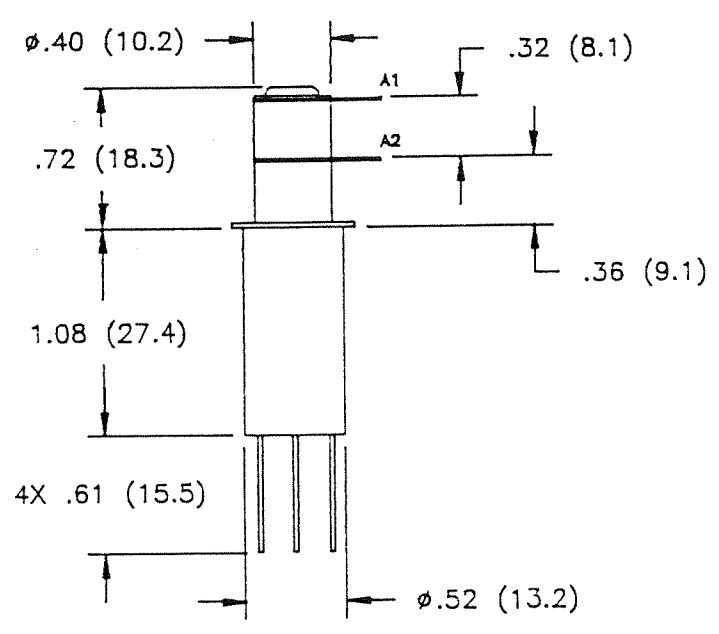
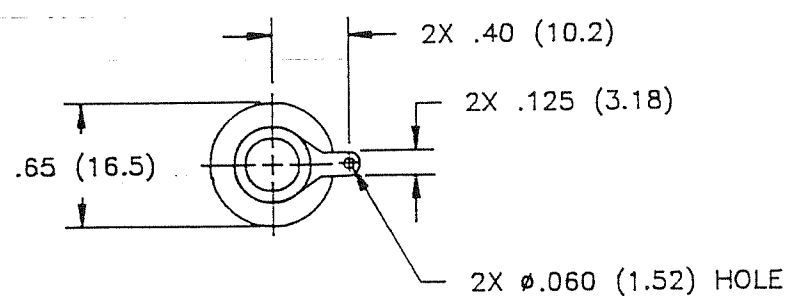

Fig. 1 OUTLINE FOR P/N K40P334

<p>DIMENSIONS IN INCHES (DIMENSIONS IN PARENTHESES ARE IN MILLIMETERS)</p> <p>TOLERANCES EXCEPT AS NOTED</p> <p>.XX = ± .03 .XXX = ± .010 X° = ± 2°</p> <p>DO NOT SCALE DWG.</p>			<p>P.O. BOX 4422 Santa Barbara, CA 93140-4422</p>	
	<p>K40P SERIES</p>			
<p>FSCM NO.</p> <p style="font-size: 18pt; text-align: center;">18741</p>	<p>SCALE</p> <p style="font-size: 18pt; text-align: center;">NONE</p>	<p>SHEET</p> <p style="font-size: 18pt; text-align: center;">4</p>		

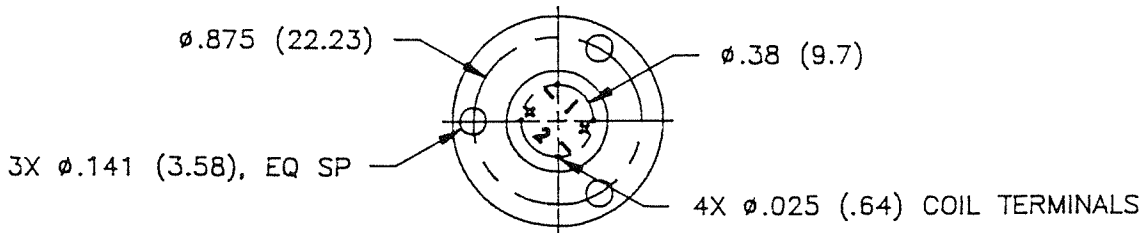
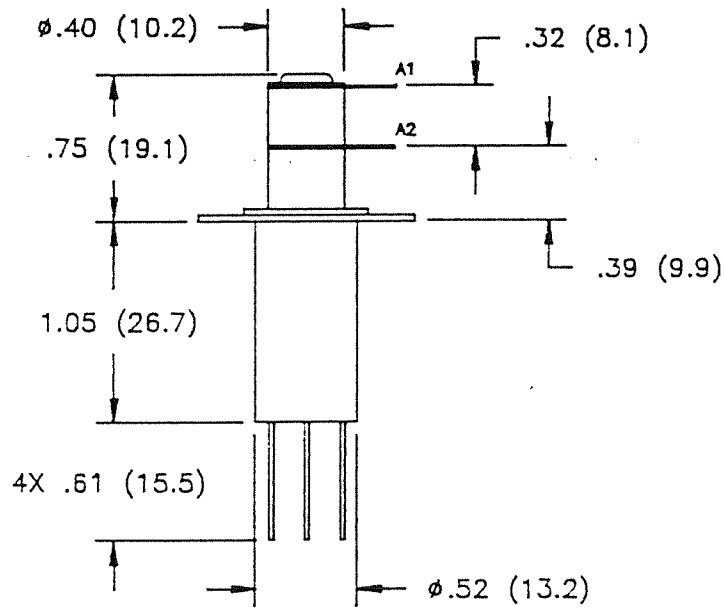
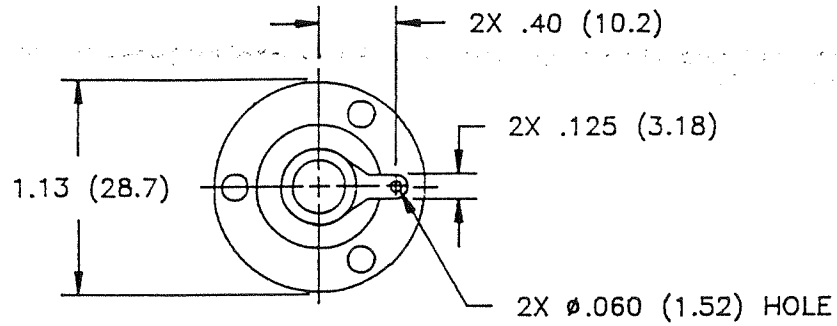

Fig. 2 OUTLINE FOR P/N K40P332

DIMENSIONS IN INCHES
(DIMENSIONS IN PARENTHESES ARE IN
MILLIMETERS)

TOLERANCES EXCEPT AS NOTED

.XX = ± .03

.XXX = ± .010

~~4~~ X° = ± 2°

DO NOT SCALE DWG.

Kilovac[®]
Corporation

P.O. BOX 4422
Santa Barbara, CA 93140-4422

K40P SERIES

FSCM NO.

18741

SCALE

NONE

SHEET

5

REV.
A

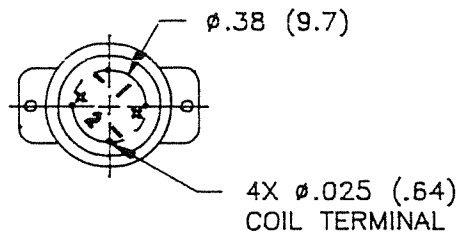
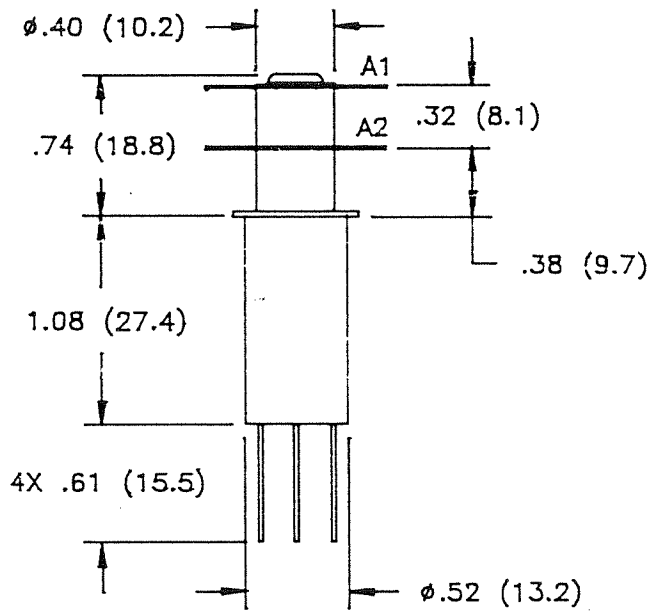
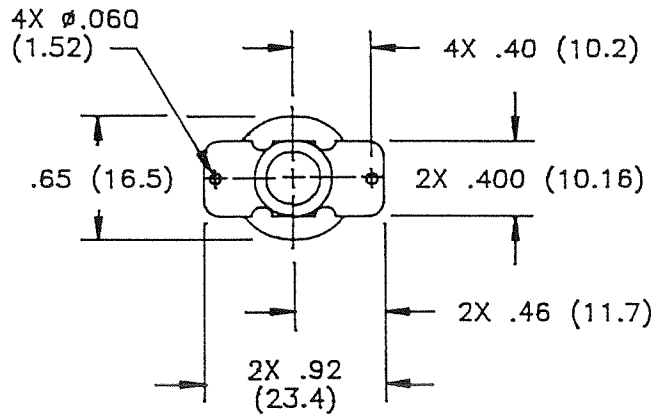

Fig. 3 OUTLINE FOR P/N K40P364

DIMENSIONS IN INCHES
 (DIMENSIONS IN PARENTHESES ARE IN
 MILLIMETERS)

TOLERANCES EXCEPT AS NOTED

.xx = \pm .03

.xxx = \pm .010

\angle x° = \pm 2°

DO NOT SCALE DWG.

Kilovac[®]
 Corporation

P.O. BOX 4422
 Santa Barbara, CA 93140-4422

K40P SERIES

CAGE CODE
 18741

SCALE
 1:1

SHEET
 6