

PART NUMBER	REVISION	DESCRIPTION	FEED TYPE
2266218-1	C	FINE CRIMP HEIGHT ADJUST	MECHANICAL
2266218-2	C	FINE CRIMP HEIGHT ADJUST	PNEUMATIC
5-2266218-1	C	FINE CRIMP HEIGHT ADJUST	MECHANICAL
5-2266218-2	C	FINE CRIMP HEIGHT ADJUST	PNEUMATIC
7-2266218-1	C	MECHANICAL AND CRIMP TOOLING KIT	MECHANICAL
7-2266218-2	C	PNEUMATIC AND CRIMP TOOLING KIT	PNEUMATIC
7-2266218-7	B	CRIMP TOOLING KIT	-

ATLANTIC VERSION TERMINATOR INTERFACE ADAPTER

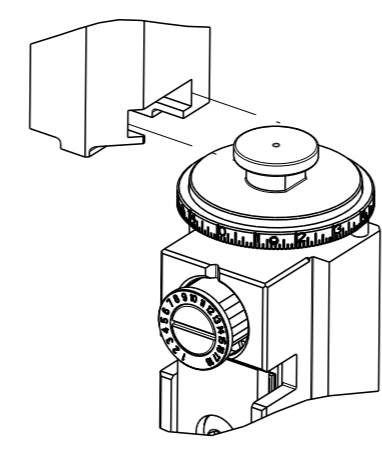

APPLICATOR DATA

CRIMP	SIZE	TYPE
WIRE	1.40 mm [.055]	F
INSUL	1.90 mm [.075]	F

APPLICATOR INSTRUCTIONS 408-35042

TERMINAL DATA: MOLEX TERMINAL MOLEX CRIMP SPECIFICATION

TERMINAL NAME: 2.5 LOW PROFILE CRIMP RECEPTACLE

WIRE STRIP LENGTH	INSULATION DIAMETER RANGE
2.40-2.90 mm [.094-.114 IN]	Ø1.40-1.60 mm [.055-.063 IN]

TERMINAL APPLICATION SPECIFICATION: ATS 639023100 Rev C

TERMINALS APPLIED

TE TERMINAL	MOLEX TERMINAL	TE TERMINAL	MOLEX TERMINAL
1572313-1	08701039	1572313-4	98000242
1572313-2	08701045	1572313-7	08701047
1572313-3	39000160		

TERMINAL DATA: MOLEX TERMINAL MOLEX CRIMP SPECIFICATION

TERMINAL NAME: 2.5 LOW PROFILE CRIMP RECEPTACLE

WIRE STRIP LENGTH	INSULATION DIAMETER RANGE
2.40-2.90 mm [.094-.114 IN]	Ø1.40-1.60 mm [.055-.063 IN]

TERMINAL APPLICATION SPECIFICATION: ATS 639023100 Rev C

TERMINALS APPLIED

TE TERMINAL	MOLEX TERMINAL	TE TERMINAL	MOLEX TERMINAL
1572313-5	456270002	1572313-6	456271002

WIRE SIZE	CRIMP HEIGHT mm [INCH]	CRIMP HEIGHT REFERENCE SETTING
22 AWG OR 0.35mm2	0.73+/-0.035 [.029+/- .001]	6.2
24 AWG OR 0.20mm2	0.67+/-0.035 [.026+/- .001]	6.9
26 AWG OR 0.12mm2	0.62+/-0.03 [.024+/- .001]	7.4
28 AWG OR 0.08mm2	0.60+/-0.03 [.024+/- .001]	7.7

WIRE SIZE	CRIMP HEIGHT mm [INCH]	CRIMP HEIGHT REFERENCE SETTING
22 AWG OR 0.35mm2	0.73+/-0.035 [.029+/- .001]	6.2
24 AWG OR 0.20mm2	0.67+/-0.035 [.026+/- .001]	6.9

- 1 RECOMMENDED SPARE PARTS
- 2 REFER TO SUPPLIED INSTRUCTION SHEET FOR CLEANING, LUBRICATION AND STORAGE OF APPLICATOR.
- 3 APPLY PART NUMBER 2-23419-6 LOCTITE TO THREADS OF ITE 242.
- 4 CRIMP HEIGHT REFERENCE SETTING WAS THE SETTING USED WHEN THE APPLICATOR WAS QUALIFIED AT THE FACTORY. ADJUSTMENT MAY BE NECESSARY WHEN RUNNING APPLICATOR IN THE FIELD.
- 5. UNLESS SPECIFIED OTHERWISE TORQUE VALUES SHALL BE USED PER DOCUMENT, 101-35000.
- 6 TERMINAL LUBRICANT IS RECOMMENDED.

***WARNING**
 ON INSTALLATION, SET WIRE DISC TO CRIMP HEIGHT REFERENCE SETTING FOR LARGEST WIRE SIZE. CRIMP HEIGHT REFERENCE SETTINGS GREATER THAN THE VALUE SHOWN MAY CAUSE DAMAGE TO THE CRIMP TOOLING. REFER TO THE INSTRUCTION SHEET FOR PROPER SETUP AND ADJUSTMENTS.

ATLANTIC VERSION
 Shown on sheets 1 of 4 & 2 of 4
 (Pacific version shown on sheets 3 of 4 & 4 of 4)

LOC	DIST	REV	DESCRIPTION	DATE	OWN	APVD
A	66	A	RELEASE	14MAR2014	XZ	GB
		B	ECR-19-016874	01NOV2019	TB	TE
		C	ECR-22-142586	16JUN2022	FJ	JAH

-	1	1	1	1	1	1	1-1803945-3	TONKER	300
-	1	1	1	1	1	1	22278-9	SPRING, COMPRESSION	299
-	2	2	2	2	2	2	4-18032-3	SCR, SET, FLT PNT, M3 X 6.0	298
-	1	1	1	1	1	1	1803944-1	SPACER, TONKER	297
-	-	-	1	1	-	-	2-1803583-1	APPLICATOR BASIC ASSEMBLY, SF	292
-	1	1	1	1	1	1	2-2119791-2	DEPRESSOR, WIRE	286
-	1	-	1	-	1	-	2119641-1	FEED CAM, AIR FEED	248
-	1	1	1	1	1	1	2119082-4	CAM, SNAIL, INSULATION ADJUSTMENT	244
-	1	1	1	1	1	1	2079764-1	WASHER, WAVE SPRING, CREST-TO-CREST	243
-	1	1	1	1	1	1	2119083-1	RETAINER, INSULATION DIAL	242
-	1	1	1	1	1	1	7-18023-7	SCR, SKT HD CAP M3 X 4.0	241
-	-	1	-	1	-	1	2119580-1	MECHANICAL FEED ASSEMBLY	239
-	1	-	1	-	1	-	2844940-1	AIR FEED MODULE	238
-	REF	REF	REF	REF	REF	REF	994970-2	COUNTER, MAGNETIC	164
-	1	1	1	1	1	1	2119955-1	ASSY, LUBRICATOR, SIDE FEED	113
-	1	1	1	1	1	1	2844908-1	SCREW, LOCKING	99
-	1	1	1	1	1	1	2844907-1	POST, LOCKING	98
-	1	1	1	1	1	1	1-455888-2	SPACER, CRIMPER	82
-	1	1	1	1	1	1	1803607-3	DOCUMENTATION PACKAGE	71
-	1	1	1	1	1	1	2-2119791-2	DEPRESSOR, WIRE	70
-	1	1	1	1	1	1	2119740-1	TAG, IDENTIFICATION	67
-	2	2	2	2	2	2	2168078-1	SCREW, DRIVE, RH, RoHS, 2 x .188	66
-	1	1	1	1	1	1	2168083-2	SCR, SKT HD CAP, RoHS, M4 X 8.0	60
-	1	1	1	1	1	1	5-18022-5	SCR, HEX HD CAP, M4 X 6.0	59
-	1	1	1	1	1	1	1338685-1	PAWL, FEED	56
-	4	4	4	4	4	4	2168083-3	SCR, SKT HD CAP, RoHS, M4 X 12.0	54
-	2	2	2	2	2	2	2168083-3	SCR, SKT HD CAP, RoHS, M4 X 12.0	53
-	1	2	1	2	1	2	18023-9	SCR, SKT HD CAP M4 X 6.0	49
-	-	1	-	1	-	1	2119652-1	FEED CAM, PRE FEED	48
-	-	1	-	1	-	1	2119653-1	FEED CAM, POST FEED	47
-	1	1	-	-	1	1	1803583-9	APPLICATOR BASIC ASSEMBLY, SF	46
-	1	1	-	-	1	1	1803515-1	RAM ASSEMBLY, SF ATLANTIC	44
-	1	1	1	1	1	1	1803602-1	SCR, BHSC, RoHS (M8 X 25)	41
-	1	1	1	1	1	1	2-1752356-6	SUPPORT, TERMINAL	34
-	2	2	2	2	2	2	2079383-5	SCR, BHSC, RoHS (M4 X 20)	33
-	2	2	2	2	2	2	2-2844962-4	SPACER, CYLINDRICAL, STRIP GUIDE	30
-	1	1	1	1	1	1	2844992-1	ASSEMBLY, STRIP GUIDE	29
-	1	1	1	1	1	1	1320928-2	STRIP GUIDE	24
-	1	1	-	-	1	1	2168083-2	SCR, SKT HD CAP, RoHS, M4 X 8.0	21
-	2	2	1	1	2	2	1-18028-2	WASHER, FLAT, REG M4	20
-	1	1	-	-	1	1	2119533-3	STRIPPER, SIDE FEED	19
-	1	1	1	1	1	1	2119806-1	INSERT, SHEAR	13
-	1	1	1	1	1	1	3-22280-3	SPRING, COMPRESSION	12
-	1	1	1	1	1	1	1-356885-4	STOP, SHEAR	11
-	1	1	1	1	1	1	2119805-1	SHEAR HOLDER, FRONT	10
-	1	1	1	1	1	1	1803095-6	FLOATING SHEAR, FRONT	9
-	1	2	2	1	1	1	1-1633139-9	ANVIL, COMBINATION	8
-	-	-	-	-	-	-	-	-	7
-	-	-	-	-	-	-	-	-	6
-	1	1	1	1	1	1	2119757-3	DEPRESSOR, SHEAR	5
-	1	1	1	1	1	1	2-238011-0	BLOCK, CRIMPER SPACER	4
-	1	2	2	1	1	1	1-1633962-9	CRIMPER, INSULATION F PREMIUM	3
-	1	2	2	1	1	1	8-456402-3	CRIMPER, WIRE PREMIUM	1

ITEM NO	PART NO	DESCRIPTION	ITEM NO
-77	-72	-71	-52
-51	-2	-1	

OWN	X. ZHAO	21FEB2014
CHK	L. ZHANG	21FEB2014
APVD	J. ELBIN	21FEB2014

NAME: Ocean Side Feed Applicator

SIZE: A1 CAGE CODE: 00779 DRAWING NO: 2266218

Customer Accessible Production Drawing SCALE: 1:2 SHEET: 1 OF 4 REV: C

REVISONS		DATE	OWN	APVD
P	LYR			
- SEE SHEET 1				

FEED TYPE MECHANICAL

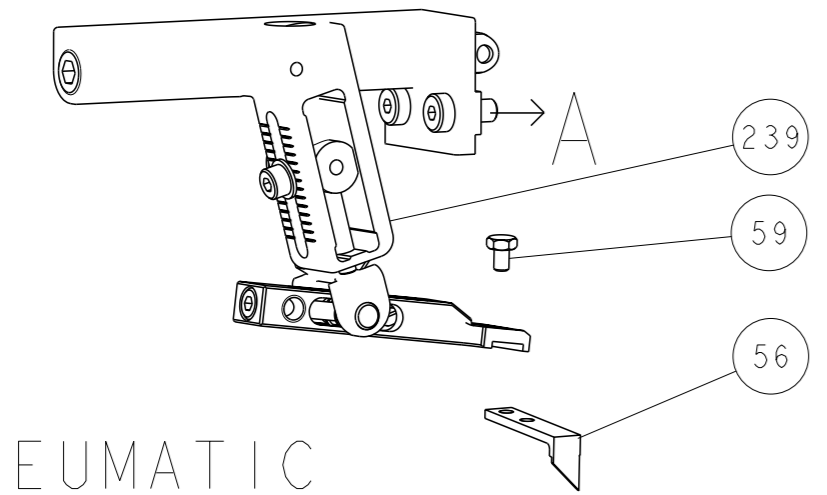

PNEUMATIC

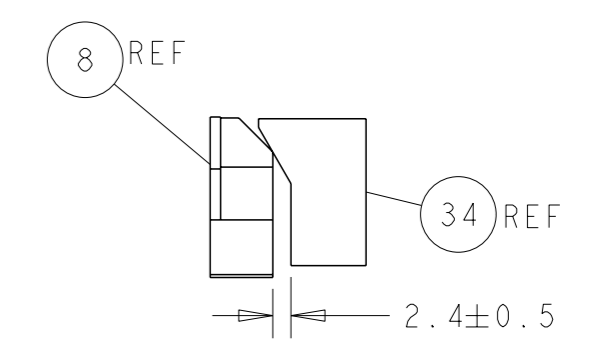
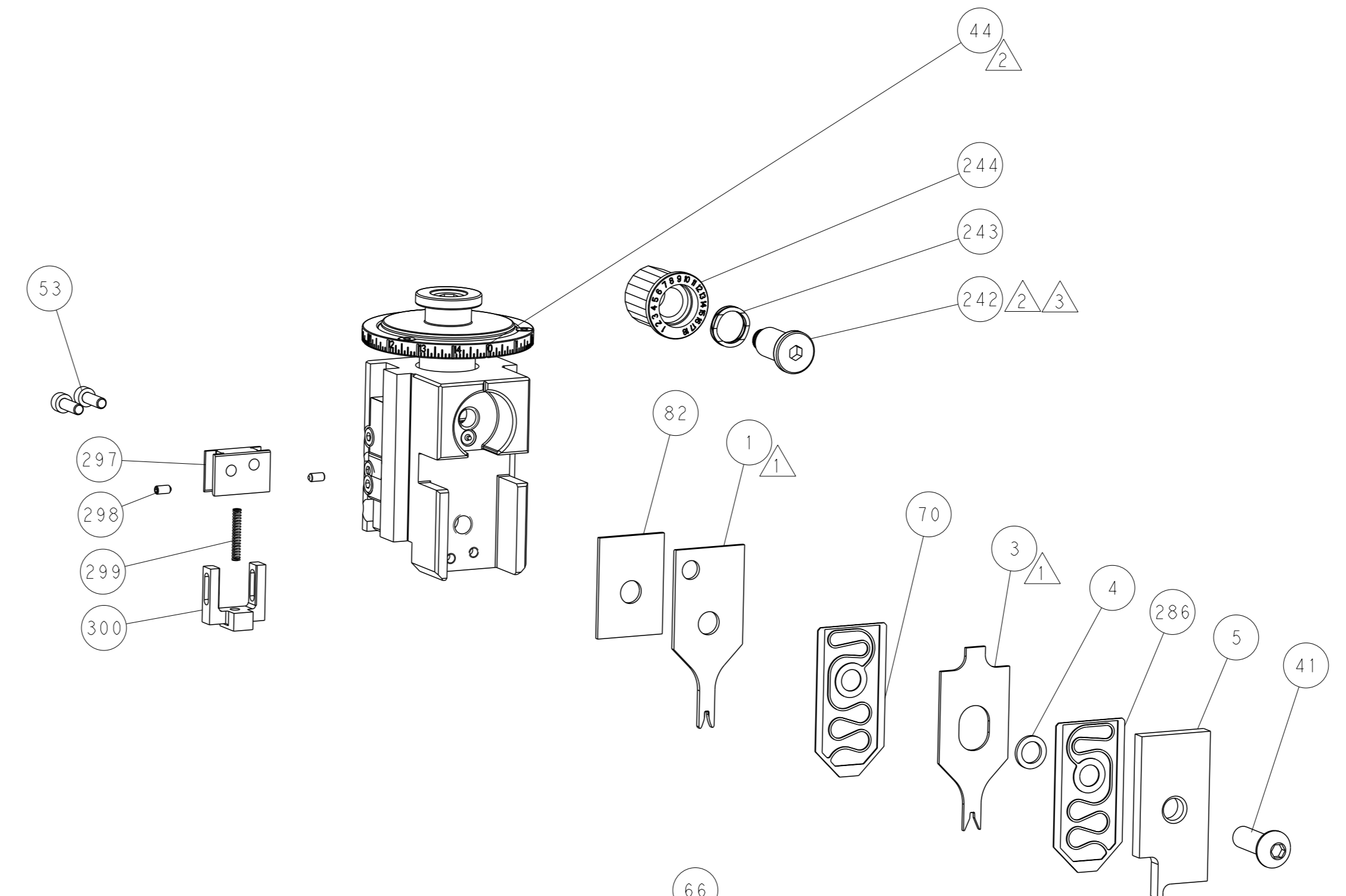
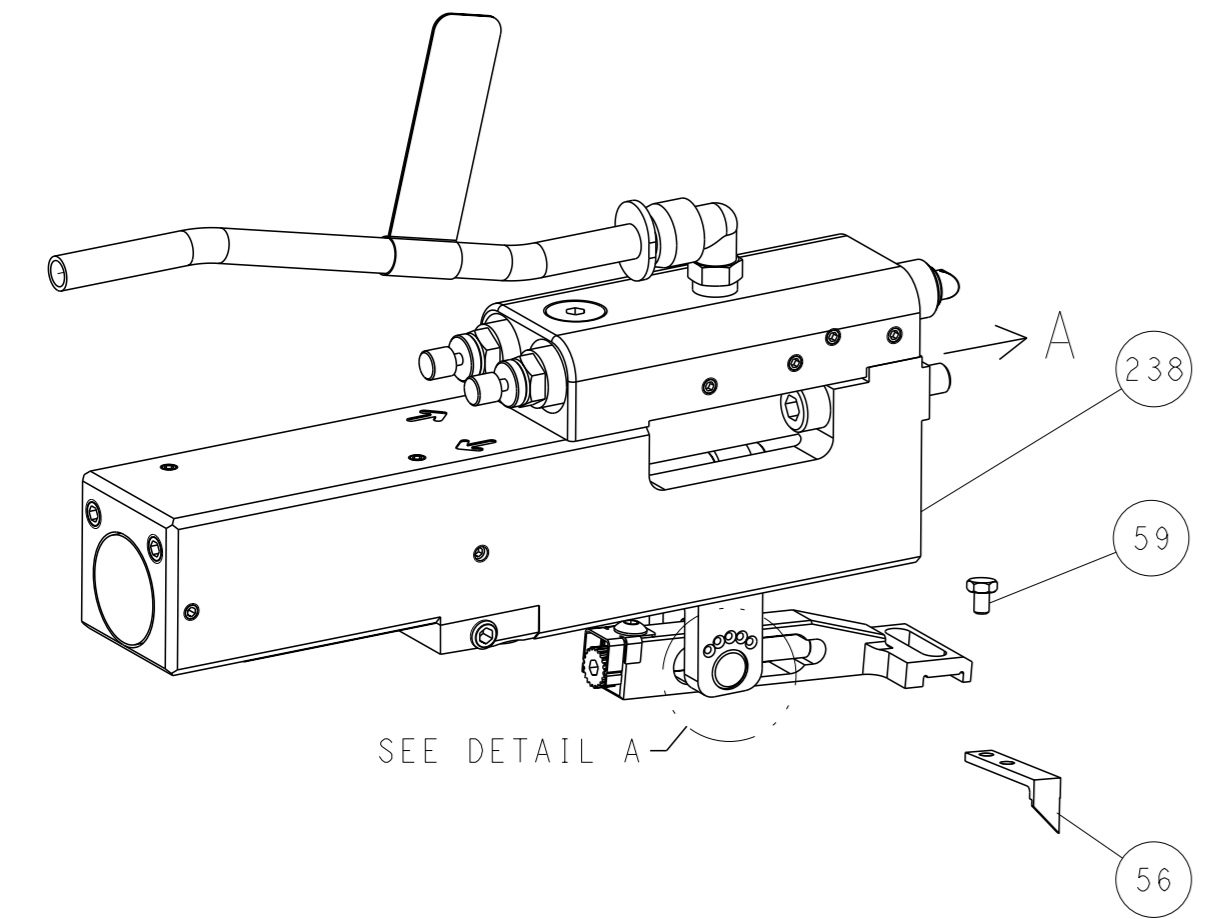

TERMINAL SUPPORT LOCATION

FEED SPRING SETTING POSITION (SHOWN FROM REAR SIDE)

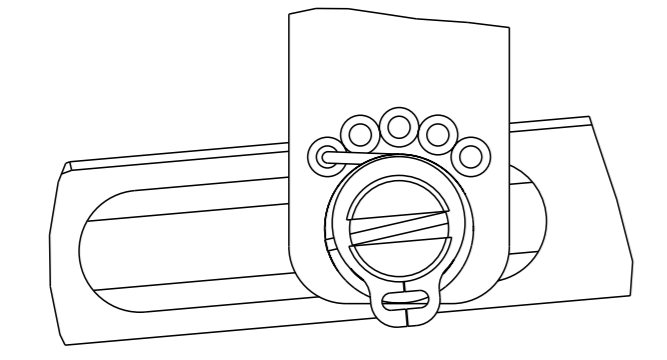

DETAIL A

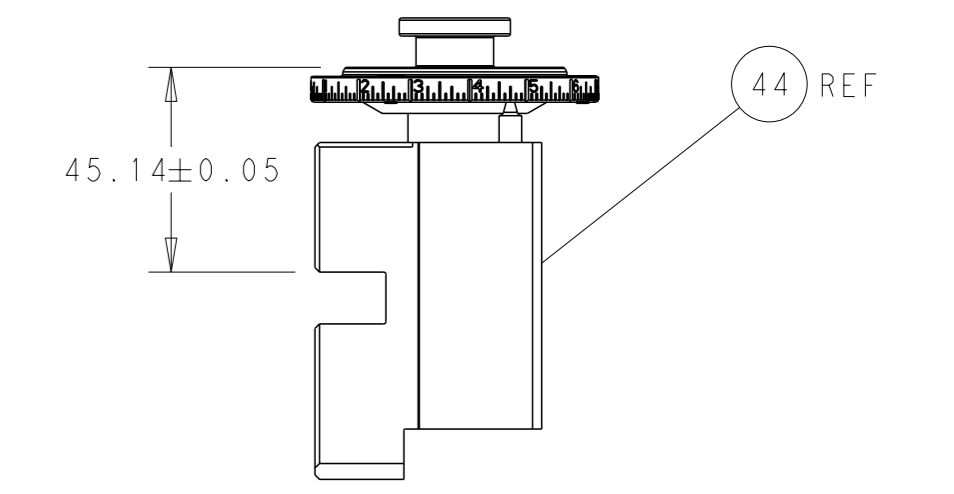
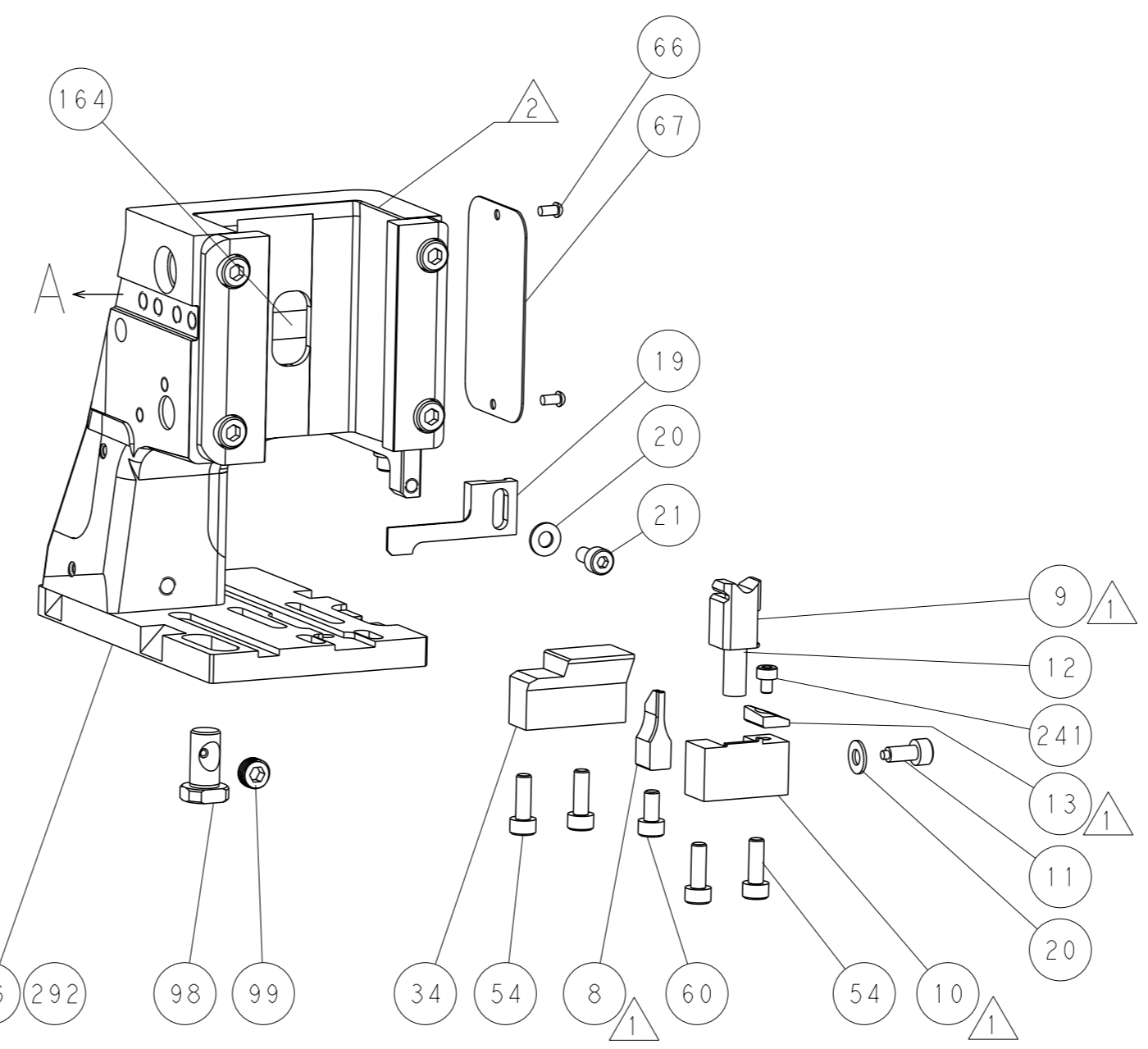
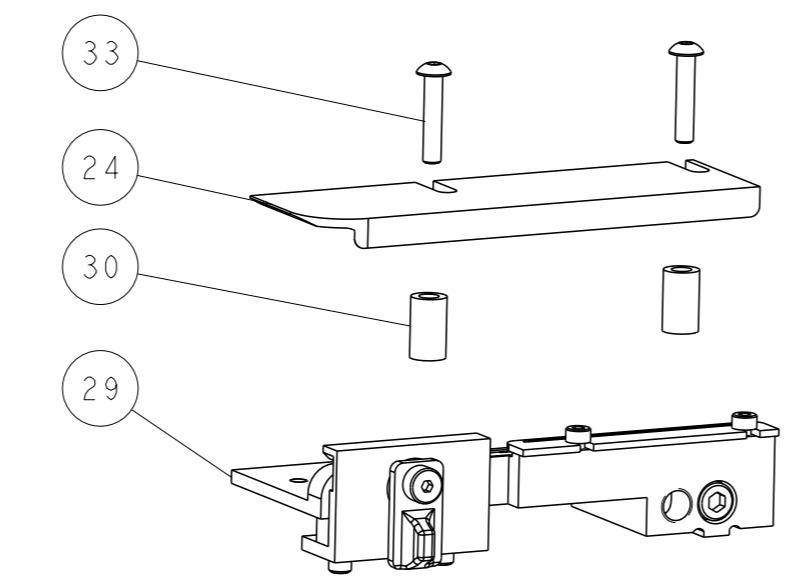

RAM SET-UP

CAM POSITIONS

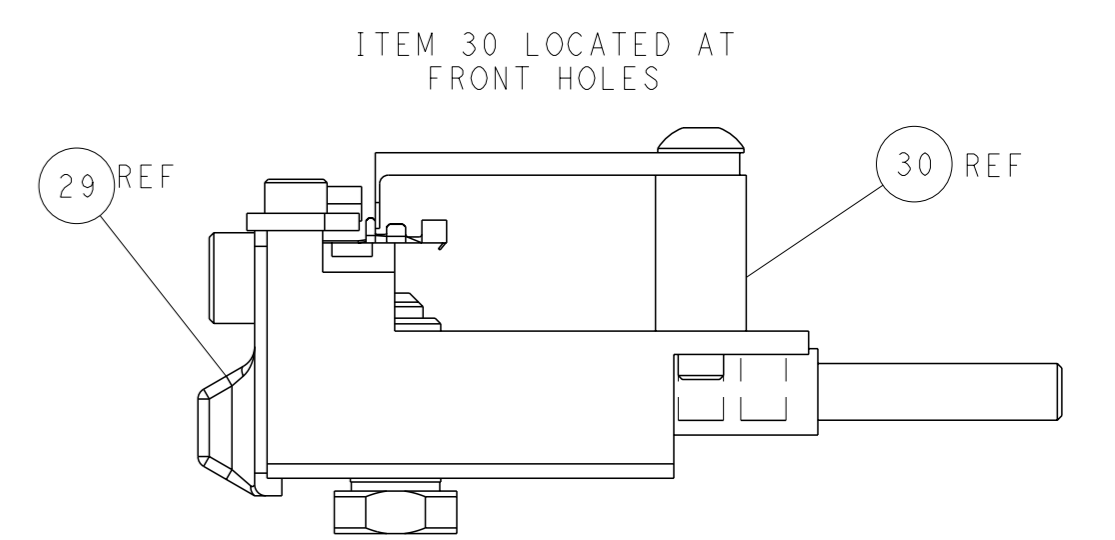
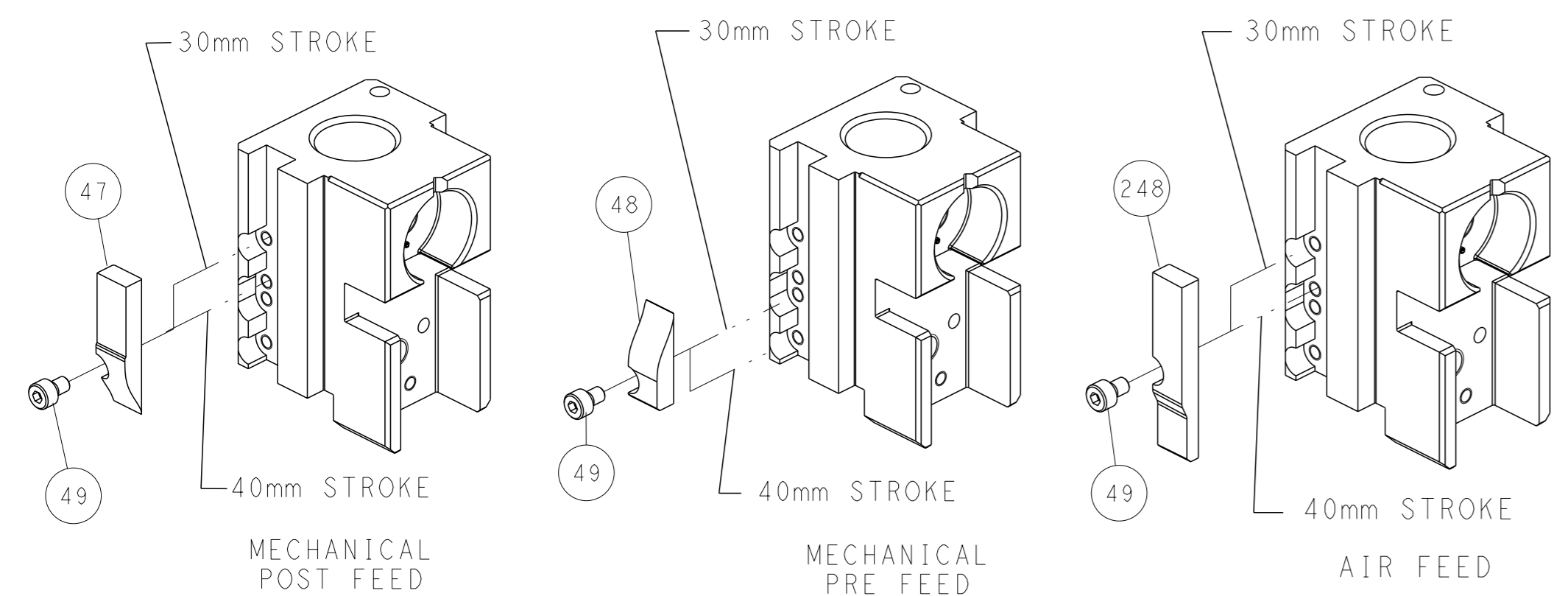

FEED TRACK POSITION GUIDE BY INSULATION BARREL

ATLANTIC VERSION
 Shown on sheets 1 of 4 & 2 of 4
 (Pacific version shown on sheets 3 of 4 & 4 of 4)

DIMENSIONS: mm TOLERANCES UNLESS OTHERWISE SPECIFIED: 0 PLC ± 1 PLC ± 2 PLC ± 3 PLC ± 4 PLC ± ANGLES FINISH ±		OWN: X.ZHAO 21FEB2014 CHK: L.ZHANG 21FEB2014 APVD: J.ELBIN 21FEB2014 PRODUCT SPEC APPLICATION SPEC WEIGHT: - SCALE: 1:2	NAME: Ocean Side Feed Applicator SIZE: A1 CAGE CODE: 00779 DRAWING NO: C=2266218 SHEET: 2 of 4 REV: C
--	--	---	--

PART NUMBER	REVISION	DESCRIPTION	FEED TYPE
2-2266218-1	C	FINE CRIMP HEIGHT ADJUST	MECHANICAL
2-2266218-2	C	FINE CRIMP HEIGHT ADJUST	PNEUMATIC
7-2266218-7	B	CRIMP TOOLING KIT	-

PACIFIC VERSION TERMINATOR
 INTERFACE ADAPTER

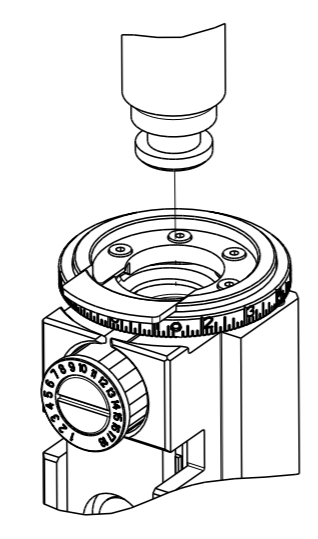

APPLICATOR DATA		
CRIMP	SIZE	TYPE
WIRE	1.40 mm (.055)	F
INSUL	1.90 mm (.075)	F
APPLICATOR INSTRUCTIONS 408-35042		

TERMINAL DATA: MOLEX TERMINAL MOLEX CRIMP SPECIFICATION			
TERMINAL NAME: 2.5 LOW PROFILE CRIMP RECEPTACLE			
WIRE STRIP LENGTH		INSULATION DIAMETER RANGE	
2.40-2.90 mm [.094-.114 IN]		Ø1.40-1.60 mm [.055-.063 IN]	
TERMINAL APPLICATION SPECIFICATION ATS 639023100 Rev C			
TERMINALS APPLIED			
TE TERMINAL	MOLEX TERMINAL	TE TERMINAL	MOLEX TERMINAL
1572313-1	08701039	1572313-4	98000242
1572313-2	08701045	1572313-7	08701047
1572313-3	39000160		

TERMINAL DATA: MOLEX TERMINAL MOLEX CRIMP SPECIFICATION			
TERMINAL NAME: 2.5 LOW PROFILE CRIMP RECEPTACLE			
WIRE STRIP LENGTH		INSULATION DIAMETER RANGE	
2.40-2.90 mm [.094-.114 IN]		Ø1.40-1.60 mm [.055-.063 IN]	
TERMINAL APPLICATION SPECIFICATION ATS 639023100 Rev C			
TERMINALS APPLIED			
TE TERMINAL	MOLEX TERMINAL	TE TERMINAL	MOLEX TERMINAL
1572313-5	456270002	1572313-6	456271002

WIRE SIZE	CRIMP HEIGHT mm [INCH]	CRIMP HEIGHT REFERENCE SETTING
22 AWG OR 0.35mm2	0.73+/-0.035 [.029+/-0.011]	6.2
24 AWG OR 0.20mm2	0.67+/-0.035 [.026+/-0.011]	6.9
26 AWG OR 0.12mm2	0.62+/-0.03 [.024+/-0.011]	7.4
28 AWG OR 0.08mm2	0.60+/-0.03 [.024+/-0.011]	7.7

WIRE SIZE	CRIMP HEIGHT mm [INCH]	CRIMP HEIGHT REFERENCE SETTING
22 AWG OR 0.35mm2	0.73+/-0.035 [.029+/-0.011]	6.2
24 AWG OR 0.20mm2	0.67+/-0.035 [.026+/-0.011]	6.9



- 1 RECOMMENDED SPARE PARTS
- 2 REFER TO SUPPLIED INSTRUCTION SHEET FOR CLEANING, LUBRICATION AND STORAGE OF APPLICATOR.
- 3 APPLY PART NUMBER 2-23419-6 LOCTITE TO THREADS OF ITE 242.
- 4 CRIMP HEIGHT REFERENCE SETTING WAS THE SETTING USED WHEN THE APPLICATOR WAS QUALIFIED AT THE FACTORY. ADJUSTMENT MAY BE NECESSARY WHEN RUNNING APPLICATOR IN THE FIELD.
- 5. UNLESS SPECIFIED OTHERWISE TORQUE VALUES SHALL BE USED PER DOCUMENT, 101-35000.
- 6 TERMINAL LUBRICANT IS RECOMMENDED.

***WARNING**
 ON INSTALLATION, SET WIRE DISC TO CRIMP HEIGHT REFERENCE SETTING FOR LARGEST WIRE SIZE. CRIMP HEIGHT REFERENCE SETTINGS GREATER THAN THE VALUE SHOWN MAY CAUSE DAMAGE TO THE CRIMP TOOLING. REFER TO THE INSTRUCTION SHEET FOR PROPER SETUP AND ADJUSTMENTS.

PACIFIC VERSION
 Shown on sheets 3 of 4 & 4 of 4
 (Atlantic version shown on sheets 1 of 4 & 2 of 4)

LOC	DIST	REV	DATE	BY	APPV
A	66	-	-	-	-

REV	DATE	BY	APPV	DESCRIPTION	ITEM NO
-	1	1	1-1803945-3	TONKER	300
-	1	1	22278-9	SPRING, COMPRESSION	299
-	2	2	4-18032-3	SCR, SET, FLT PNT, M3 X 6.0	298
-	1	1	1803944-1	SPACER, TONKER	297
-	1	1	2-2119791-2	DEPRESSOR, WIRE	286
-	1	1	2119082-4	CAM, SNAIL, INSULATION ADJUSTMENT	244
-	1	1	2079764-1	WASHER, WAVE SPRING, CREST-TO-CREST	243
-	1	1	2119083-1	RETAINER, INSULATION DIAL	242
-	1	1	7-18023-7	SCR, SKT HD CAP M3 X 4.0	241
-	-	1	2119580-1	MECHANICAL FEED ASSEMBLY	239
-	1	-	2844940-1	AIR FEED MODULE	238
-	REF	REF	994970-2	COUNTER, MAGNETIC	164
-	1	-	2119641-2	FEED CAM, AIR FEED	151
-	1	1	2168083-8	SCR, SKT HD CAP, RoHS, M4 X 16	144
-	4	4	2168083-9	SCR, SKT HD CAP, RoHS, M4 X 20	143
-	-	1	2119653-2	FEED CAM, POST FEED	142
-	1	1	1-1803583-0	APPLICATOR BASIC ASSEMBLY, SF	141
-	1	1	1803516-1	RAM ASSEMBLY, SF PACIFIC	140
-	1	1	2119955-1	ASSY, LUBRICATOR, SIDE FEED	113
-	1	1	2844908-1	SCREW, LOCKING	99
-	1	1	2844907-1	POST, LOCKING	98
-	1	1	1-455888-2	SPACER, CRIMPER	82
-	1	1	1803607-3	DOCUMENTATION PACKAGE	71
-	1	1	2-2119791-2	DEPRESSOR, WIRE	70
-	1	1	2119740-1	TAG, IDENTIFICATION	67
-	2	2	2168078-1	SCREW, DRIVE, RH, RoHS, 2 x .188	66
-	1	1	5-18022-5	SCR, HEX HD CAP, M4 X 6.0	59
-	1	1	1338685-1	PAWL, FEED	56
-	2	2	2168083-3	SCR, SKT HD CAP, RoHS, M4 X 12.0	53
-	1	2	18023-9	SCR, SKT HD CAP M4 X 6.0	49
-	-	1	2119652-1	FEED CAM, PRE FEED	48
-	1	1	1803602-1	SCR, BHSC, RoHS (M8 X 25)	41
-	1	1	2-1752356-6	SUPPORT, TERMINAL	34
-	2	2	2079383-5	SCR, BHSC, RoHS (M4 X 20)	33
-	2	2	2-2844962-4	SPACER, CYLINDRICAL, STRIP GUIDE	30
-	1	1	2844992-1	ASSEMBLY, STRIP GUIDE	29
-	1	1	1320928-2	STRIP GUIDE	24
-	1	1	2168083-2	SCR, SKT HD CAP, RoHS, M4 X 8.0	21
-	2	2	1-18028-2	WASHER, FLAT, REG M4	20
-	1	1	2119533-3	STRIPPER, SIDE FEED	19
-	1	1	2119806-1	INSERT, SHEAR	13
-	1	1	3-22280-3	SPRING, COMPRESSION	12
-	1	1	1-356885-4	STOP, SHEAR	11
-	1	1	2119805-1	SHEAR HOLDER, FRONT	10
-	1	1	1803095-6	FLOATING SHEAR, FRONT	9
-	1	1	1-1633139-9	ANVIL, COMBINATION	8
-	-	-	-	-	7
-	-	-	-	-	6
-	1	1	2119757-3	DEPRESSOR, SHEAR	5
-	1	1	2-238011-0	BLOCK, CRIMPER SPACER	4
-	1	1	1-1633962-9	CRIMPER, INSULATION F PREMIUM	3
-	1	1	8-456402-3	CRIMPER, WIRE PREMIUM	1
-	77	22	21	PART NO	
-	-	-	-	DESCRIPTION	
-	-	-	-	ITEM NO	

DIMENSIONS:		TOLERANCES UNLESS OTHERWISE SPECIFIED:		OWN X ZHAO 21FEB2014		NAME	
mm	0 PLC ±	1 PLC ±	2 PLC ±	3 PLC ±	4 PLC ±	APV L ZHANG 21FEB2014	TE Connectivity Harrisburg, PA 17105-3608
		FINISH		APV L ZHANG 21FEB2014		Ocean Side Feed Applicator	
MATERIAL		WEIGHT		SIZE	CAGE CODE	DRAWING NO	RESTRICTED TO
				A1	00779	2266218	
Customer Accessible Production Drawing				SCALE	1:2	SHEET	3 of 4

LOC		DIST		REVISIONS			
A	66	P	LYR	DESCRIPTION	DATE	OWN	APVD
		-		SEE SHEET 1			

FEED TYPE MECHANICAL

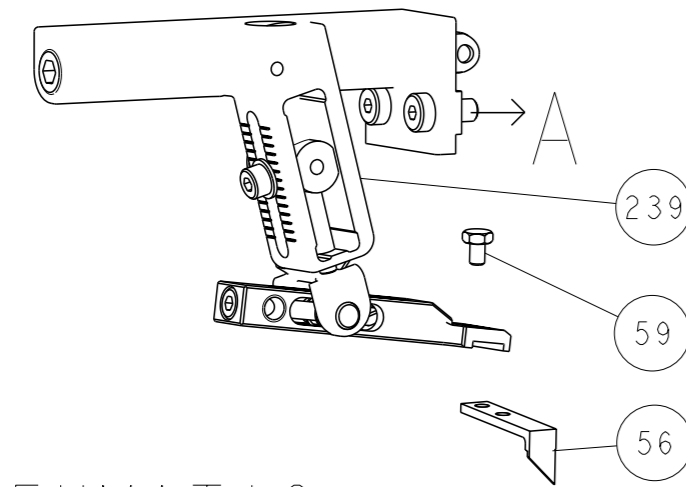

PNEUMATIC

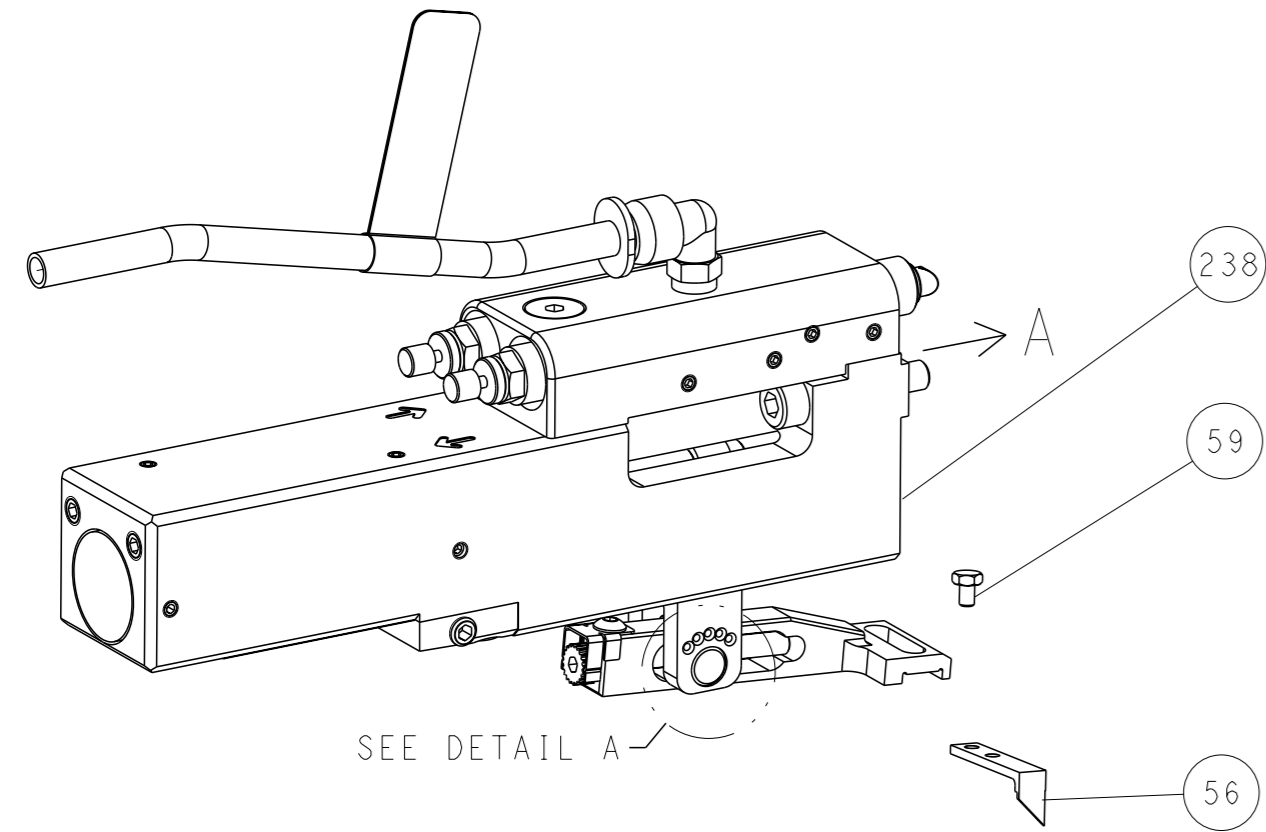

FEED SPRING SETTING POSITION (SHOWN FROM REAR SIDE)

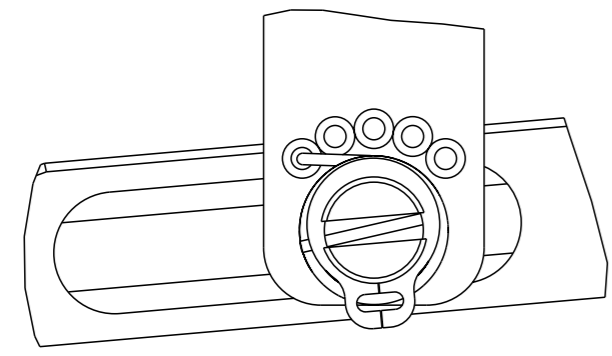

DETAIL A

CAM POSITIONS

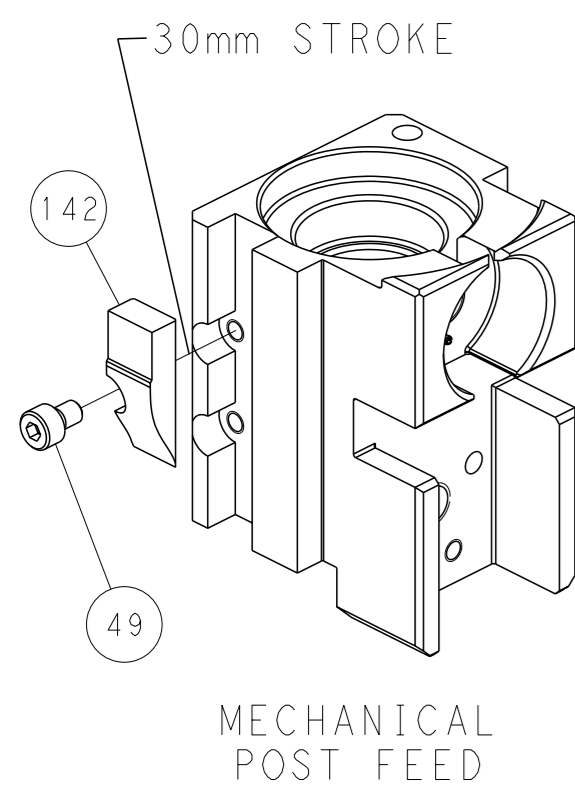

MECHANICAL
POST FEED

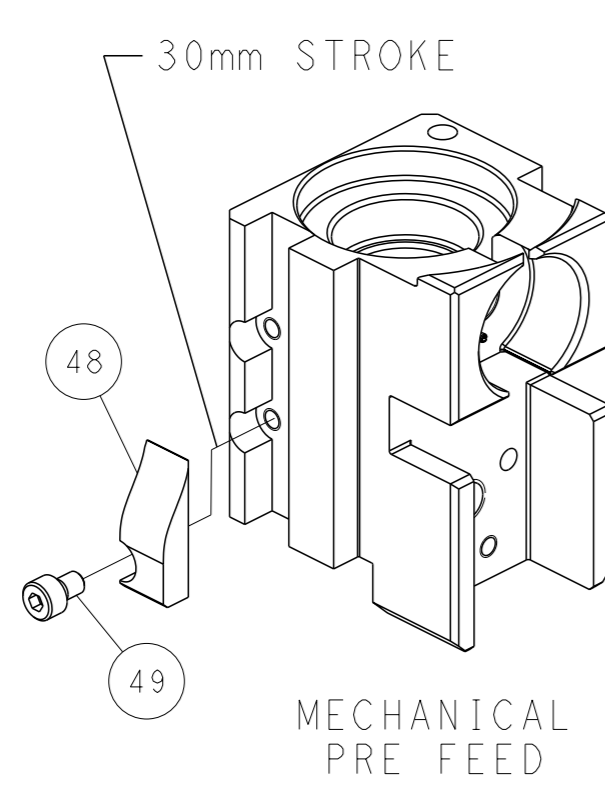

MECHANICAL
PRE FEED

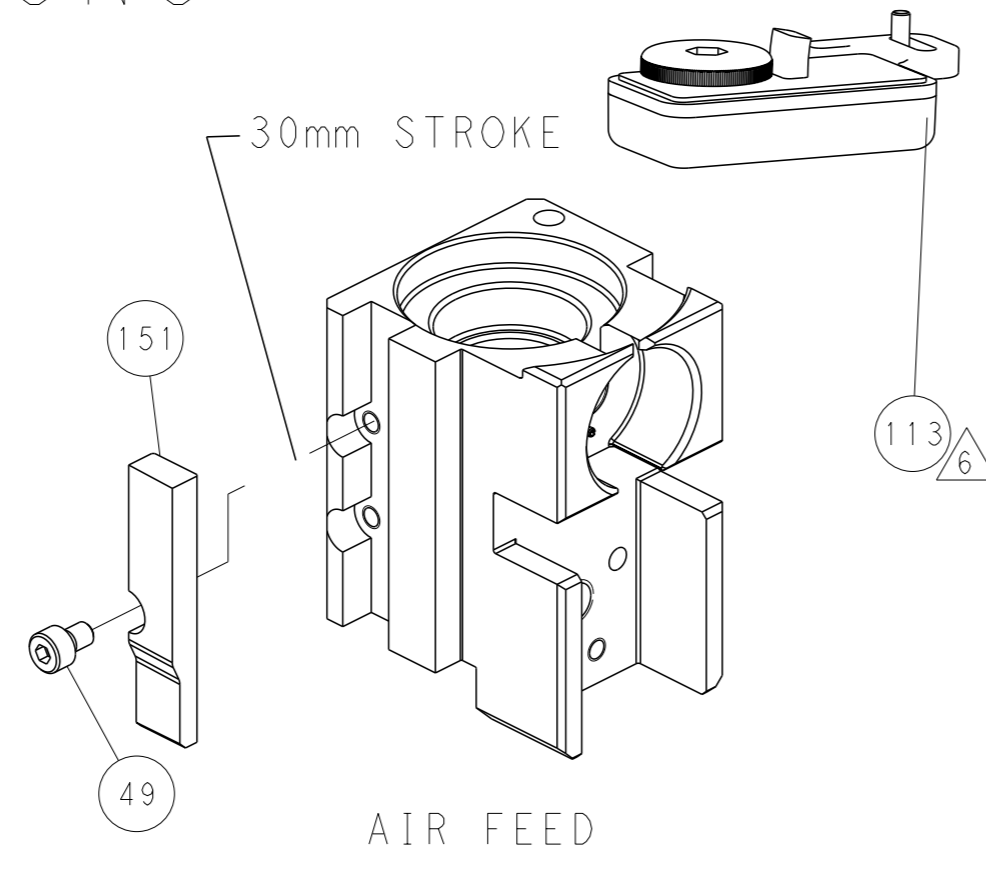

AIR FEED

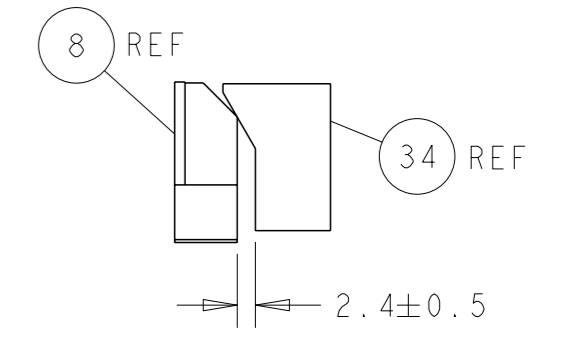
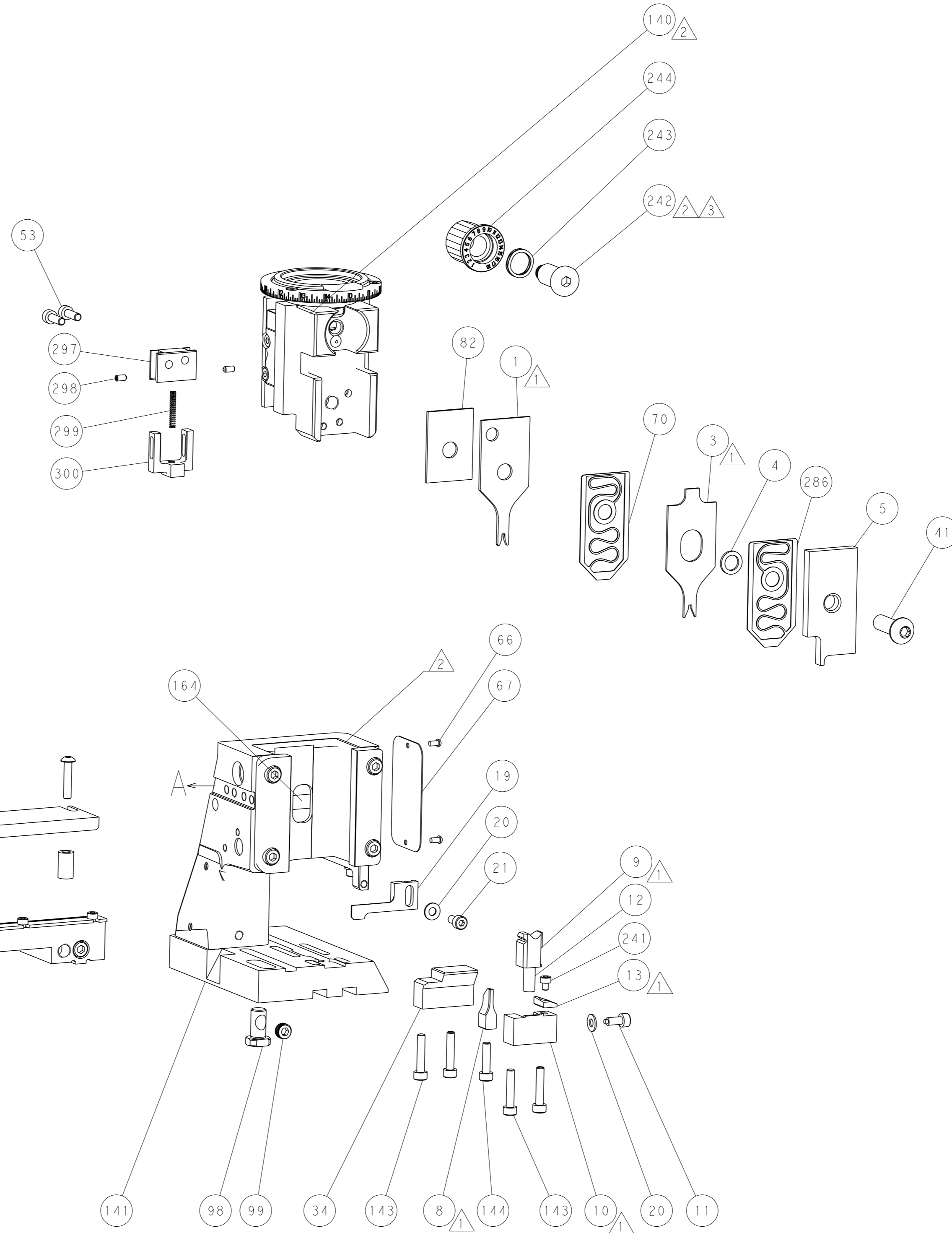

TERMINAL SUPPORT LOCATION

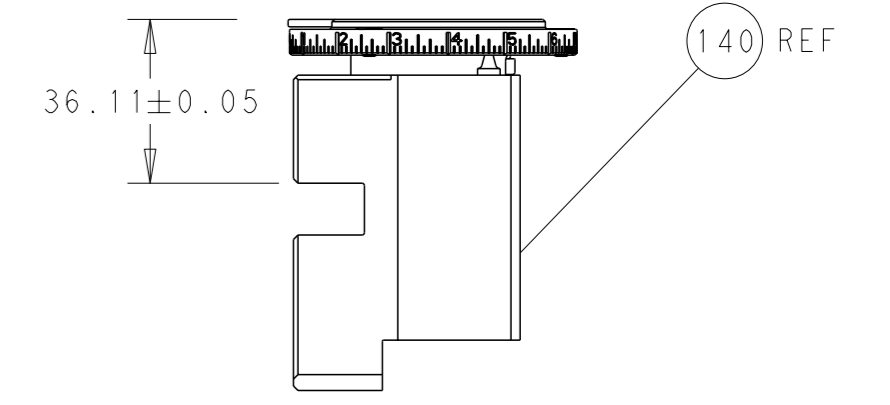

RAM SET-UP

ITEM 30 LOCATED AT
FRONT HOLES

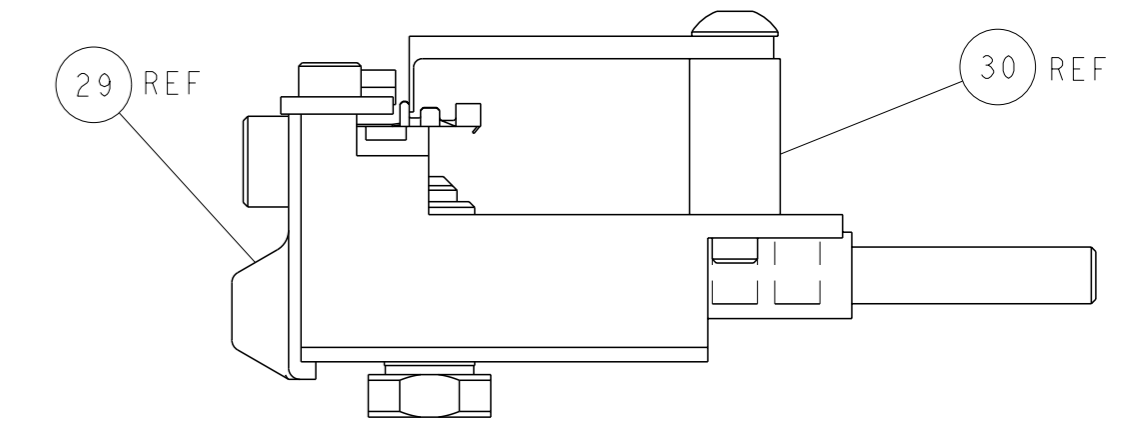

FEED TRACK POSITION
GUIDE BY INSULATION BARREL

PACIFIC VERSION
 Shown on sheets 3 of 4 & 4 of 4
 (Atlantic version shown on sheets 1 of 4 & 2 of 4)

<small>THIS DRAWING IS A CONTROLLED DOCUMENT FOR TYCO ELECTRONICS CORPORATION. IT IS SUBJECT TO CHANGE AND THE USER'S RESPONSIBILITY TO OBTAIN THE LATEST REVISION SHOULD BE CONTACTED FOR THE LATEST REVISION.</small>		OWN: X. ZHAO CHK: L. ZHANG APVD: J. ELBIN	21FEB2014 21FEB2014 21FEB2014	NAME: TE Connectivity Harrisburg, PA 17105-3608
DIMENSIONS: mm TOLERANCES UNLESS OTHERWISE SPECIFIED: 0 PLC ± 1 PLC ± 2 PLC ± 3 PLC ± 4 PLC ± ANGLES FINISH ±	APPLICATION SPEC WEIGHT SCALE: 1:2	SIZE: A1 CAGE CODE: 00779 DRAWING NO: C=2266218	RESTRICTED TO: - SHEET 4 OF 4 REV C	CUSTOMER ACCESSIBLE PRODUCTION DRAWING