

DRA3P SERIES

DIN RAIL MOUNT



Features

- 2.4 & 4.2 Amp rated Solid State Contactor
- Load voltage range of 48-510 VAC, 3-Phase
- Fits standard 35mm DIN-RAIL
- LED input status indicator
- AC or DC control
- Zero-crossing (resistive loads) or instantaneous turn-on (inductive loads) output
- cUL Recognized, IEC Rated, CE, CCC & RoHS Compliant, Horsepower Rated
- Built in Overvoltage Protection

PRODUCT SELECTION

Control Voltage	2.4A	4.2A
4 - 6 VDC Control	DRA3P48D2	DRA3P48D4
18 - 28 VDC Control	DRA3P48E2	DRA3P48E4
36 - 60 VAC Control	DRA3P48C2	DRA3P48C4
90 - 140 VAC Control	DRA3P48B2	DRA3P48B4
200 - 265 VAC Control	DRA3P48A2	DRA3P48A4

SPECIFICATIONS

AC Output ⁽¹⁾

Description	2.4A	4.2A
Operating Voltage (47-63Hz) [Vrms]	48 - 510	48 - 510
Rated Operating Voltage (Vrms)	480	480
Transient Overvoltage [Vpk] ⁽²⁾	1200	1200
Maximum Resistive Load Current UL/AC51 [Arms] ^{(3) (8)}	2.4 / 2.4	4.2 / 2.4
Maximum Motor Load Current UL/AC53 [Arms] ^{(3) (4)}	2.1 / 2.1	3.4 / 2.1

Description	2.4A	4.2A
Maximum Load Current [Arms]	0.15	0.15
Maximum Off-State Leakage Current @ Rated Voltage [mArms]	1.0	1.0
Maximum Off-State dv/dt @ Rated Voltage [V/μsec]	500	500
Maximum On-State Voltage Drop @ Rated Current [Vrms]	1.15 per Channel	1.15 per Channel
Maximum Surge Current (50/60 Hz, 1 cycle) [Apk]	410 / 375	410 / 375
HP/IEC 60947 Rating @ 240V, 40°C [HP/KW] ⁽⁵⁾	0.5 / 0.37	0.75 / 0.37
HP/IEC 60947 Rating @ 380V, 40°C [HP/KW] ⁽⁶⁾	1.0 / 0.75	1.5 / 0.75
HP/IEC 60947 Rating @ 480V, 40°C [HP/KW] ⁽⁷⁾	1.0 / 0.75	2.0 / 0.75
Minimum Power Factor (with Maximum Load)	0.5	0.5
Min/Max Stranded/Solid Wire [AWG]	24 / 10	24 / 10
Min/Max Stranded/Solid Wire [IEC mm ²]	0.5 - 4.0	0.5 - 4.0
Load Terminal Screw Torque Range	12.0 in lb (1.36 Nm)	12.0 in lb (1.36 Nm)

Input ⁽¹⁾

Description	DRA3P48Dx	DRA3P48Ex	DRA3P48Cx	DRA3P48Bx	DRA3P48Ax
Control Voltage Range	4 - 6 VDC	18 - 28 VDC	36 - 60 VAC	90 - 140 VAC	200 - 265 VAC
Rated Input Control Voltage	5 VDC	24 VDC	48 VAC	120 VAC	230 VAC
Minimum Turn-On Voltage	4 VDC	18 VDC	36 VAC	90 VAC	200 VAC
Minimum Turn-Off Voltage	2 VDC	4 VDC	10 VAC	20 VAC	60 VAC
Minimum Input Current [mA]	17	15	7.5	5	4.5
Maximum Input Current [mA]	35	25	13.5	8	5.7
Nominal Input Impedance [Ohms]	120	1.2K	4.2K	16K	46K
Maximum Turn-on Time ⁽⁹⁾	½ Cycle	½ Cycle	20 ms	20 ms	20 ms
Maximum Turn-Off Time	½ Cycle	½ Cycle	30 ms	30 ms	30 ms
Min / Max Stranded/Solid Wire [AWG]	24 / 12	24 / 12	24 / 12	24 / 12	24 / 12
Min / Max Stranded/Solid Wire [IEC mm ²]	0.5 - 2.5	0.5 - 2.5	0.5 - 2.5	0.5 - 2.5	0.5 - 2.5
Control Terminal Screw Torque Range	4.3 in lb (0.485 Nm)	4.3 in lb (0.485 Nm)	4.3 in lb (0.485 Nm)	4.3 in lb (0.485 Nm)	4.3 in lb (0.485 Nm)

General ⁽¹⁾

Description	Parameters
Dielectric Strength, Input to Output (50/60 Hz)	3750 Vrms
Minimum Insulation Resistance (@ 500 V DC)	10 ⁹ Ohm
Maximum Capacitance, Input/Output	20 pF
Ambient Operating Temperature Range	-20 to 60°C
Ambient Storage Temperature Range	-40 to 85°C
LED Status Indicator for Control Input	On: Green
Weight (Typical)	4.75 oz (135 g)
Housing Material (Bottom Cover)	PVC Class V0 (UL94)
Housing Material (End Pieces)	Polyamide Class V0 (UL94)

DIAGRAMS

Wiring Diagram

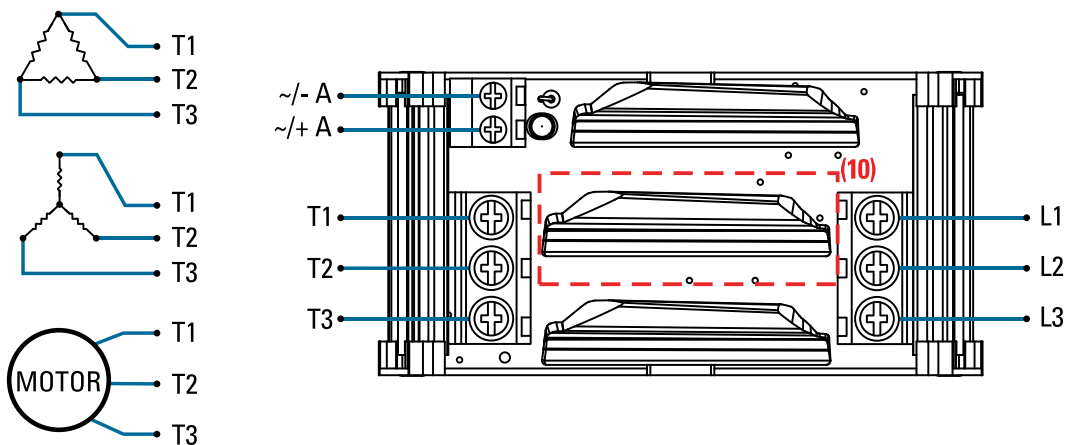

Block Diagram

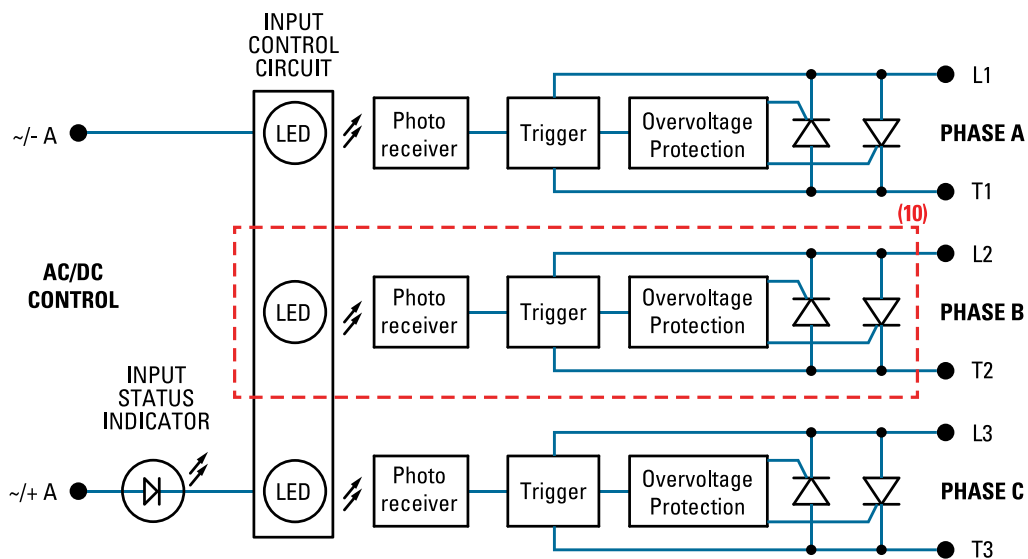



MECHANICAL SPECIFICATIONS

Tolerances: ± 0.02 in / 0.5 mm
All dimensions are in inches [millimeters]

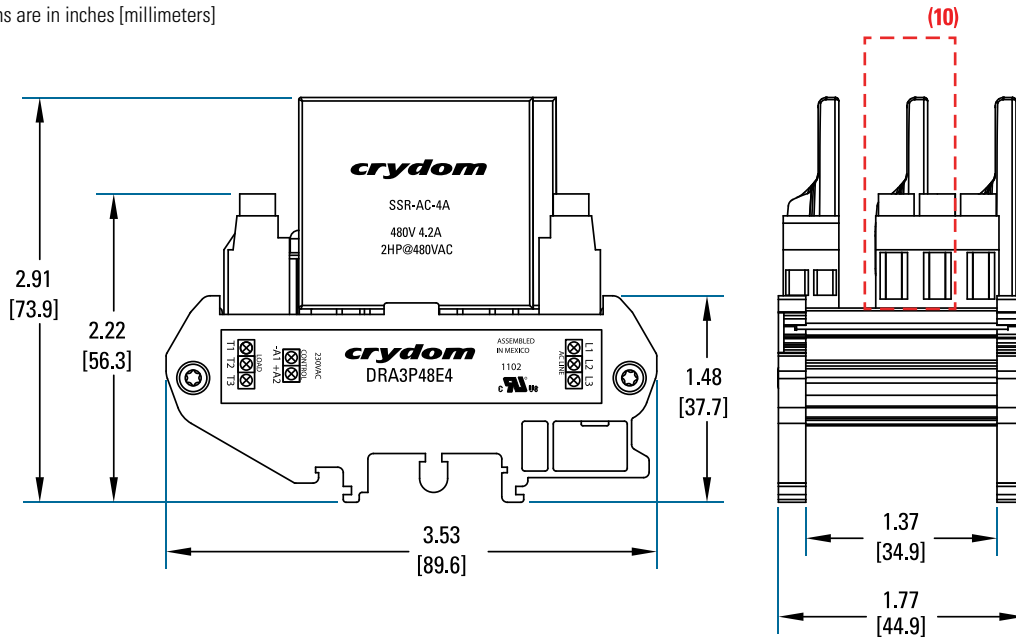

THERMAL DERATE INFORMATION

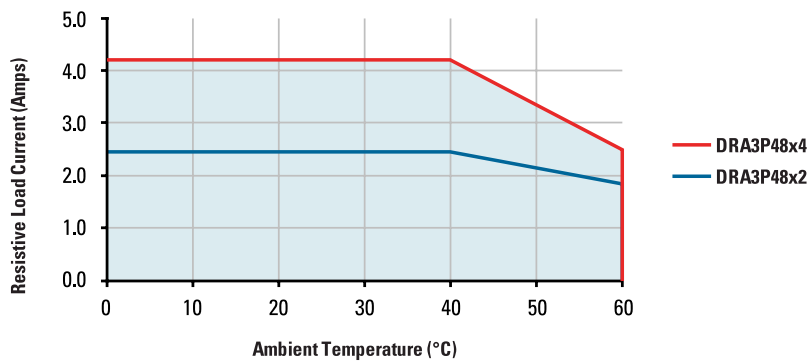

Ratings based on single or multiple relays and no spacing between units except AC control which is 3.4 A rating 45mm spacing must be used.



ORDERING OPTIONS

Example : DRA3P48D4R2

3 Phase Function, 48-510 VAC Operating Voltage, 4-6 VDC Control Voltage, 4.2 Amp/ 2HP @ 480 VAC Rated Load Current, Instantaneous Turn-On Switching Type, 2 Controlled Legs

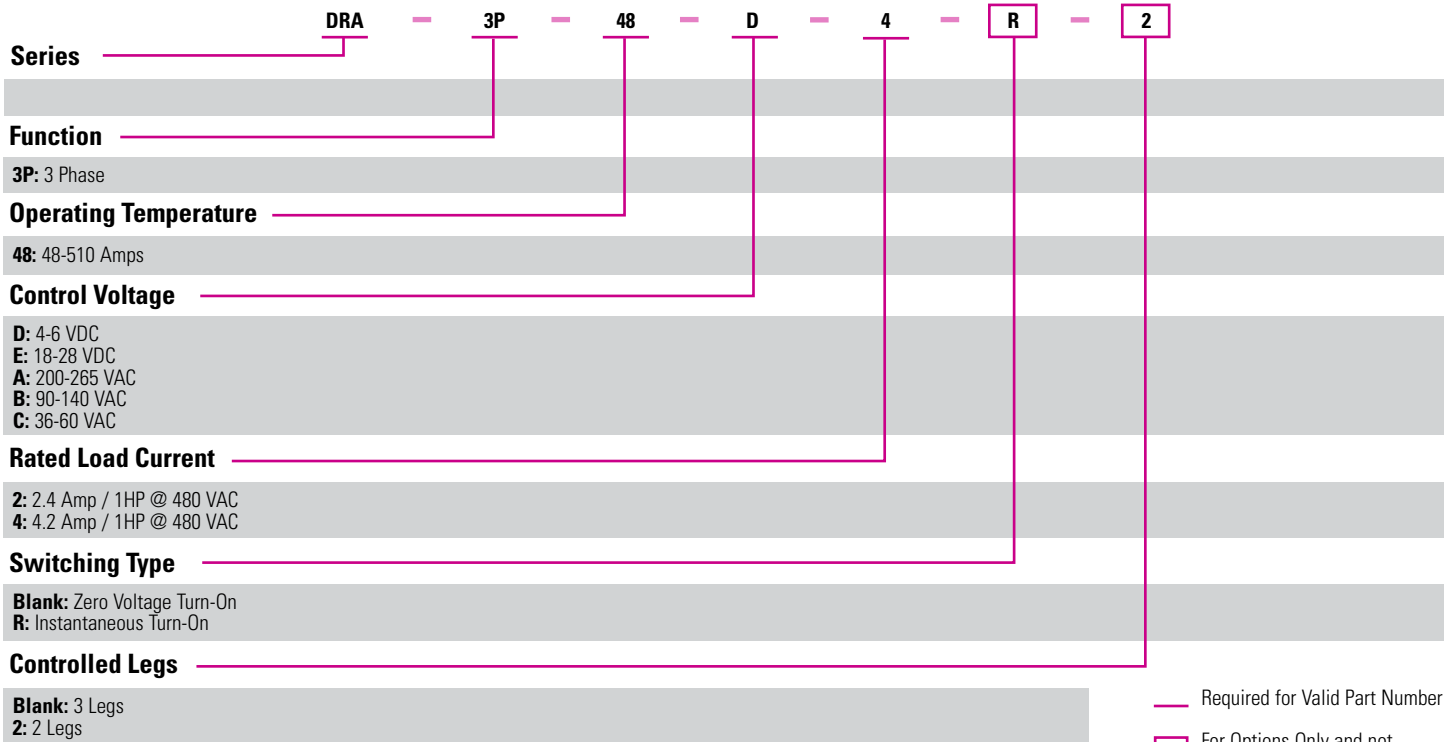

GENERAL NOTES

- (1) All parameters at 25 °C unless otherwise specified.
- (2) Relay will self trigger between 900-1200 Vpk. Not suitable for capacitive loads.
- (3) For AC control AC53 maximum current is 1.6A
- (4) Mounted in the vertical position (Din Rail in horizontal position).
- (5) For AC control, rating is ½ HP / 0.25 KW
- (6) For AC control, rating is 1 HP / 0.37 KW
- (7) For AC control, rating is 1 HP / 0.55 KW
- (8) Resistive Load Current rating for DRA3P48x4 (A,B & C suffix only) is 3.4 A
- (9) Turn-on time for DC control instantaneous turn-on versions is 0.1 msec.
- (10) Three Controlled legs versions only. Otherwise L2-T2 are connected internally.

For additional information or specific questions, contact Sensata Technical Support.



AGENCY APPROVALS & CERTIFICATIONS



- UL: E116950
- CCC: Except DRA3P48xxx2)



WARNINGS



RISK OF MATERIAL DAMAGE AND HOT ENCLOSURE

- The product's side panels may be hot, allow the product to cool before touching
- Follow proper mounting instructions including torque values
- Do not allow liquids or foreign objects to enter this product

Failure to follow these instructions can result in serious injury, or equipment damage.



HAZARD OF ELECTRIC SHOCK, EXPLOSION OR ARC FLASH

- Disconnect all power before installing or working with this equipment
- Verify all connections and replace all covers before turning on power

Failure to follow these instructions will result in death or serious injury.

Sensata Technologies, Inc. ("Sensata") data sheets are solely intended to assist designers ("Buyers") who are developing systems that incorporate Sensata products (also referred to herein as "components"). Buyer understands and agrees that Buyer remains responsible for using its independent analysis, evaluation and judgment in designing Buyer's systems and products. Sensata data sheets have been created using standard laboratory conditions and engineering practices. Sensata has not conducted any testing other than that specifically described in the published documentation for a particular data sheet. Sensata may make corrections, enhancements, improvements and other changes to its data sheets or components without notice.

Buyers are authorized to use Sensata data sheets with the Sensata component(s) identified in each particular data sheet. HOWEVER, NO OTHER LICENSE, EXPRESS OR IMPLIED, BY ESTOPPEL OR OTHERWISE TO ANY OTHER SENSATA INTELLECTUAL PROPERTY RIGHT, AND NO LICENSE TO ANY THIRD PARTY TECHNOLOGY OR INTELLECTUAL PROPERTY RIGHT, IS GRANTED HEREIN. SENSATA DATA SHEETS ARE PROVIDED "AS IS". SENSATA MAKES NO WARRANTIES OR REPRESENTATIONS WITH REGARD TO THE DATA SHEETS OR USE OF THE DATA SHEETS, EXPRESS, IMPLIED OR STATUTORY, INCLUDING ACCURACY OR COMPLETENESS. SENSATA DISCLAIMS ANY WARRANTY OF TITLE AND ANY IMPLIED WARRANTIES OF MERCHANTABILITY, FITNESS FOR A PARTICULAR PURPOSE, QUIET ENJOYMENT, QUIET POSSESSION, AND NON-INFRINGEMENT OF ANY THIRD PARTY INTELLECTUAL PROPERTY RIGHTS WITH REGARD TO SENSATA DATA SHEETS OR USE THEREOF.

All products are sold subject to Sensata's terms and conditions of sale supplied at www.sensata.com SENSATA ASSUMES NO LIABILITY FOR APPLICATIONS ASSISTANCE OR THE DESIGN OF BUYERS' PRODUCTS. BUYER ACKNOWLEDGES AND AGREES THAT IT IS SOLELY RESPONSIBLE FOR COMPLIANCE WITH ALL LEGAL, REGULATORY AND SAFETY-RELATED REQUIREMENTS CONCERNING ITS PRODUCTS, AND ANY USE OF SENSATA COMPONENTS IN ITS APPLICATIONS, NOTWITHSTANDING ANY APPLICATIONS-RELATED INFORMATION OR SUPPORT THAT MAY BE PROVIDED BY SENSATA.

Mailing Address: Sensata Technologies, Inc., 529 Pleasant Street, Attleboro, MA 02703, USA.

CONTACT US

Americas

+1 (877) 502 5500 – Option 2

sales.crydom@sensata.com

Europe, Middle East & Africa

+44 (1202) 416170

ssr-info.eu@sensata.com

Asia Pacific

sales.isasia@list.sensata.com

China +86 (21) 2306 1500

Japan +81 (45) 277 7117

Korea +82 (31) 601 2004

India +91 (80) 67920890

Rest of Asia +886 (2) 27602006

ext 2808