

ATLANTIC VERSION TERMINATOR INTERFACE ADAPTER	PART NUMBER	REVISION	DESCRIPTION	FEED TYPE	
	2266248-1	B	FINE CRIMP HEIGHT ADJUST	MECHANICAL	SUPERSEDED BY 5-2151030-1
	2266248-2	B	FINE CRIMP HEIGHT ADJUST	PNEUMATIC	SUPERSEDED BY 5-2151030-2
	2266248-5	B	FINE CRIMP HEIGHT ADJUST	SERVO LATCH PLATE ⁴	OBSOLETE
	2266248-6	B	NON CRIMP HEIGHT ADJUST	SERVO LATCH PLATE ⁴	OBSOLETE
	2266248-7	B	FINE CRIMP HEIGHT ADJUST	NONE	OBSOLETE
	7-2266248-7	A	CRIMP TOOLING KIT	-	

APPLICATOR DATA		
CRIMP	SIZE	TYPE
WIRE	1.57 mm [.062]	F
INSUL	2.79 mm [.110]	F
APPLICATOR INSTRUCTIONS 408-10389		

TERMINAL DATA: TE TERMINAL		TE CRIMP SPECIFICATION	
TERMINAL NAME: MINI UNIVERSAL MATE-N-LOK			
WIRE STRIP LENGTH	INSULATION DIAMETER RANGE		
3.20-3.70 mm [.126-.146 IN]	Ø		
TERMINAL APPLICATION SPECIFICATION	(A)114-16017	(A)114-13089	
	(B)114-5050		
TERMINALS APPLIED			
TE TERMINAL	TE TERMINAL	TE TERMINAL	TE TERMINAL
(A) 770903-1	(A) 770904-1	(A) 794137-1	(B) 170360-6
(A) 770903-2	(A) 770904-2	(A) 794137-2	(B) 170362-1
(A) 770903-3	(A) 770904-3	(A) 794137-3	(B) 170362-2
(A) 770903-4	(A) 770904-4	(A) 1-794137-0	(B) 170362-3
(A) 770903-5	(A) 770904-5	(B) 170360-1	(B) 170362-4
(A) 770903-6	(A) 770904-6	(B) 170360-2	(B) 170362-6
(A) 1-770903-0	(A) 1-770904-0	(B) 170360-3	(B) 1-170362-3
(A) 1-770903-1	(A) 1-770904-1	(B) 170360-4	

WIRE SIZE	CRIMP HEIGHT mm [INCH]	CRIMP HEIGHT REFERENCE SETTING
18 AWG	1.07+/-0.05 [.042+/-0.002]	6.7
0.75mm2	1.04+/-0.05 [.041+/-0.002]	7.0
20 AWG OR 0.50mm2	0.91+/-0.05 [.036+/-0.002]	8.5
2 X 22 AWG	0.91+/-0.05 [.036+/-0.002]	8.5
22 AWG OR 0.35mm2	0.81+/-0.05 [.032+/-0.002]	9.5

- RECOMMENDED SPARE PARTS
- GREASE BEARING SURFACES LIGHTLY
- LUBRICATE DAILY PER THE APPLICATOR INSTRUCTION SHEET SUPPLIED WITH THE APPLICATOR.
- APPLICATOR SPECIFIC DATA TO BE ENTERED INTO BLANK MEMORY CHIP AT ASSEMBLY. SEE BELOW FOR PART NUMBER:
MECHANICAL FEED WITH "SMART APPLICATOR" CONVERSION: 8-2266248-4
PNEUMATIC FEED WITH "SMART APPLICATOR" CONVERSION: 8-2266248-4
SERVO FEED WITH "FINE CRIMP HEIGHT ADJUST": 8-2266248-5
SERVO FEED WITH "NON-CRIMP HEIGHT ADJUST": 8-2266248-6
- ADJUSTMENT OF THE STRIPPER MAY BE REQUIRED WHEN MOVING THE APPLICATOR BETWEEN BENCH AND LEADMAKER APPLICATIONS.
- APPLY PART NUMBER 1-23419-5 LOCTITE TO THREADS OF ITEMS 62 & 180. APPLY PART NUMBER 2-23419-6 LOCTITE TO THREADS OF ITEM 242. FOR -6 ONLY APPLY PART NUMBER 1-23419-5 LOCTITE TO THREADS OF ITEMS 37 & 180.
- GREASE THREADS, GROOVE AND O-RING ON ITEMS 35 & 252.
- MAGNET, ITEM 166 MUST BE ORIENTED CORRECTLY IN ORDER TO PROPERLY ACTUATE THE COUNTER.
- CRIMP HEIGHT REFERENCE SETTING WAS THE SETTING USED WHEN THE APPLICATOR WAS QUALIFIED AT THE FACTORY. ADJUSTMENT MAY BE NECESSARY WHEN RUNNING APPLICATOR IN THE FIELD.
- SPARE FEED CAM STORAGE LOCATION REFER TO INSTRUCTION SHEET FOR ADDITIONAL INFORMATION.
- TO CONVERT THE APPLICATOR TO A NON-CARRIER CUTTING STYLE, REMOVE ITEM 13 AND ATTACH TO THE LOCATION ON THE BACK SIDE OF THE HOUSING. REFER TO INSTRUCTION SHEET FOR ADDITIONAL INFORMATION.
- WHEN ASSEMBLING A NON CRIMP HEIGHT ADJUST APPLICATOR (-6) USE SHIMS FROM ITEM 260 TO ACHIEVE A NOMINAL SHIM HEIGHT OF 4.73.

TERMINAL PART NUMBER	INSULATION RANGE
770903	1.5-2.4mm
770904	
170362	
170360	
794137	1.5-2.8mm

- THIS APPLICATOR IS SPECIFIC FOR USE IN A STRIPPER CRIMPER TERMINATING UNIT.
- 114-13089 IS FOR SEAL APPLICATION ONLY. "F" TYPE INSULATION CRIMP IS USED AT A REDUCED INSULATION PAD SETTING FOR SEAL APPLICATIONS.
- TERMINAL LUBRICANT IS RECOMMENDED.

***WARNING**
ON INSTALLATION, SET WIRE DISC, ITEM 40 TO LARGEST WIRE SIZE SETTING. USE OF SETTINGS BELOW MINIMUM REQUIRED CRIMP HEIGHT SETTING WILL CAUSE DAMAGE TO CRIMP TOOLING.

-	-	1	-	-	-	2119957-2	APPLICATOR SHIM PACK	260
-	1	-	1	1	1	8-21084-0	O-RING, .676 ID, .070 DIA. MAT.	252
-	-	-	-	1	-	2119640-1	PUSH ROD, AIR FEED	250
-	-	-	-	1	-	2079988-1	BUSHING, LCH5-12, MISUMI	249
-	-	-	-	1	-	2119641-1	FEED CAM, AIR FEED	248
-	1	-	1	1	1	2119798-1	DETENT PIN	247
-	1	-	1	1	1	1-22279-3	SPRING, COMPRESSION	246
-77	-7	-6	-5	-2	-1	PART NO	DESCRIPTION	ITEM NO

ATLANTIC VERSION
Shown on sheets 1 of 4 & 2 of 4
(Pacific version shown on sheets 3 of 4 & 4 of 4)

SET UP GAUGE	LOC	DIST	REVISIONS					
2119599-1	A	66	#	LYR	DESCRIPTION	DATE	OWN	APVD
			A		RELEASED	19MAR2015	LG	GB
			B		ECR-16-010528	21JUL2016	KH	CT
			B1		ECR-18-005797	20APR2018	JAH	JDG

-	-	1	-	-	-	2119758-1	RAM, AMP STYLE, SIDE FEED, NON-ADJ.	245
-	1	1	1	1	1	2119082-9	CAM, SNAIL, INSULATION ADJUSTMENT	244
-	1	1	1	1	1	2079764-1	WASHER, WAVE SPRING, CREST-TO-CREST	243
-	1	1	1	1	1	2119083-1	RETAINER, INSULATION DIAL	242
-	1	1	1	1	1	7-18023-7	SCR, SKT HD CAP M3 X 4.0	241
-	-	2	2	-	-	2168400-6	SHCS, LOW HEAD, RoHS, M5 X 16	240
-	-	-	-	-	1	2119580-1	MECHANICAL FEED ASSEMBLY	239
-	-	-	-	1	-	2063440-1	AIR FEED MODULE	238
-	-	1	1	-	-	2119740-2	TAG, IDENTIFICATION	213
-	-	1	1	-	-	1901094-3	SPACER, FEEDER	198
-	1	1	1	1	1	4-1722335-3	STRIPPER, SIDE FEED	182
-	1	1	1	1	1	1-5018030-0	NUT, HEX, REG, RoHS, M3.5	181
-	1	1	1	1	1	1-1752354-9	STANDOFF, HOLD-DOWN	180
-	1	1	1	1	1	9931111-1	PIN, SLOTTED SPRING 3.0 X 20.0	177
-	1	1	1	1	1	5-22280-0	SPRING, COMPRESSION	176
-	1	1	1	1	1	1752353-3	GUIDE PIN, HOLDDOWN	175
-	1	1	1	1	1	1901680-2	GUIDE PIN, HOLDDOWN	174
-	-	-	-	2	-	21045-3	RING, RETAIN, EXTERN, 3/16 CRESCENT	172
-	1	1	1	1	1	994969-1	MAGNET, RARE EARTH HIGH ENERGY	166
-	REF	REF	REF	REF	REF	994970-2	COUNTER, MAGNETIC	164
-	-	-	-	1	-	240638-1	SPRING, FEED FINGER	163
-	-	-	-	1	-	3-23627-7	PIN, RETAIN, GRVD, 3/16 X .854	137
-	-	-	-	1	-	2119799-1	HOLDER, FEED FINGER, AF	136
-	-	REF	REF	-	-	SEE NOTE 4	MEMORY CHIP, PROGRAMMED	135
-	-	1	1	-	-	1633743-1	SERVO FEED LATCH ASM	133
-	-	REF	REF	-	-	2119944-1	FEED FINGER ASSEMBLY, SF	117
-	1	1	1	1	1	2119955-1	ASSY, LUBRICATOR, SIDE FEED	113
-	1	1	1	1	1	455888-5	SPACER, CRIMPER	82
-	1	1	1	1	1	2119956-1	DOCUMENTATION PACKAGE	71
-	1	-	-	1	1	2119740-1	TAG, IDENTIFICATION	67
-	2	2	2	2	2	2168078-1	SCREW, DRIVE, RH, RoHS, 2 x .188	66
-	1	-	1	1	1	2119793-1	LIMITER, ADJUSTMENT BOLT	63
-	3	-	3	3	3	992763-5	SCR, SET, SOC, CONE PNT, M3 x 4.0	62
-	1	1	1	1	1	2079383-4	SCR, BHSC, RoHS (M4 X 8)	60
-	-	-	-	1	1	5-18022-5	SCR, HEX HD CAP, M4 X 6.0	59
-	-	-	-	1	1	1338685-1	PAWL, FEED	56
-	4	4	4	4	4	2168400-1	SHCS, LOW HEAD, RoHS, M4 X 12	54
-	2	2	2	2	2	2168083-3	SCR, SKT HD CAP, RoHS, M4 X 12.0	53
-	1	1	1	1	1	5018030-1	NUT, HEX, REG, RoHS, M3	52
-	1	1	1	1	1	811242-5	BUMPER, HOLD DOWN	51
-	1	1	1	1	1	690753-2	SPACER, TONKER	50
-	-	-	-	1	2	18023-9	SCR, SKT HD CAP M4 X 6.0	49
-	-	-	-	-	1	2119652-1	FEED CAM, PRE FEED	48
-	-	-	-	-	1	2119653-1	FEED CAM, POST FEED	47
-	1	1	1	1	1	2-2119656-1	APPLICATOR BASIC ASSEMBLY, SF	46
-	1	-	1	1	1	2119370-1	RAM, AMP STYLE, SIDE FEED	44
-	1	1	1	1	1	2079383-7	SCR, BHSC, RoHS (M8 X 25)	41
-	1	-	1	1	1	2119645-1	DISC, NUMBERED FA WIRE ADJUSTMENT	40
-	1	-	1	1	1	2119957-1	APPLICATOR SHIM PACK	39
-	1	1	1	1	1	2119644-1	RAM WASHER, PRECISION	38
-	1	1	1	1	1	2119085-1	FA HEAD, ATLANTIC STYLE	37
-	1	-	1	1	1	2119092-1	BOLT, ADJUSTMENT	35
-	1	1	1	1	1	1752356-6	SUPPORT, TERMINAL	34
-	2	2	2	2	2	2079383-5	SCR, BHSC, RoHS (M4 X 20)	33
-	1	1	1	1	1	2161328-1	HEX HEAD, FLANGED, M5 x 8mm LONG	32
-	1	1	1	1	1	1320908-6	SPACER, STRIP GUIDE	30
-	1	1	1	1	1	2119959-2	ASSEMBLY, STRIP GUIDE	29
-	1	1	1	1	1	1-455888-0	SPACER, CRIMPER	28
-	1	1	1	1	1	1320928-2	STRIP GUIDE	24
-	1	1	1	1	1	1-18028-2	WASHER, FLAT, REG M4	20
-	1	1	1	1	1	2119806-1	INSERT, SHEAR	13
-	1	1	1	1	1	3-22280-3	SPRING, COMPRESSION	12
-	1	1	1	1	1	1-356885-4	STOP, SHEAR	11
-	1	1	1	1	1	2119805-1	SHEAR HOLDER, FRONT	10
-	1	1	1	1	1	1803095-1	FLOATING SHEAR, FRONT	9
-	1	1	1	1	1	1338691-1	ANVIL, COMBINATION .062	8
-	1	1	1	1	1	3-240641-3	SPACER	7
-	-	-	-	-	-	-	-	6
-	1	1	1	1	1	2119757-2	DEPRESSOR, SHEAR	5
-	1	1	1	1	1	2-238011-2	BLOCK, CRIMPER SPACER	4
-	1	1	1	1	1	2-2119582-1	CRIMPER, INSULATION F PREMIUM	3
-	1	1	1	1	1	455888-1	SPACER, CRIMPER	2
-	1	1	1	1	1	1-456403-6	CRIMPER, WIRE PREMIUM	1
-77	-7	-6	-5	-2	-1	PART NO	DESCRIPTION	ITEM NO

DIMENSIONS:		TOLERANCES UNLESS OTHERWISE SPECIFIED:		OWN		TE Connectivity	
mm	0 PLC ±	1 PLC ±	2 PLC ±	3 PLC ±	4 PLC ±	5 PLC ±	ANGLES FINISH
MATERIAL				WEIGHT	SIZE	CAGE CODE	DRAWING NO
					A1	00779	2266248
Customer Accessible Production Drawing				SCALE	1:2	SHEET	1 of 4

LOC		DIST		REVISIONS			
A	66	P	LYR	DESCRIPTION	DATE	OWN	APVD
		-		SEE SHEET 1			

FEED TYPE MECHANICAL

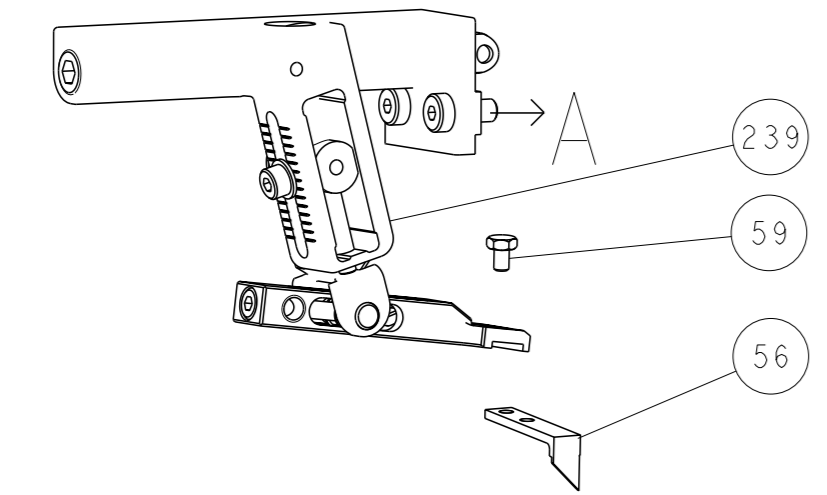

PNEUMATIC

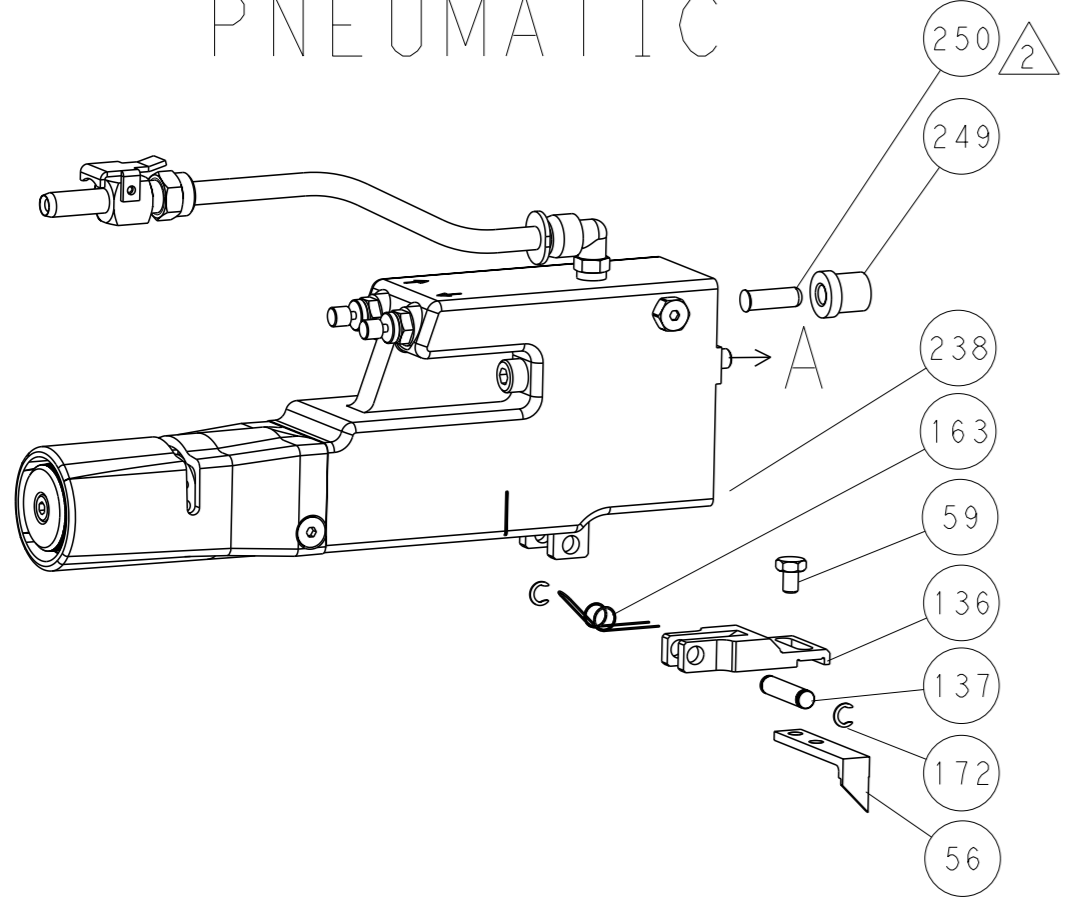

SERVO LATCH PLATE

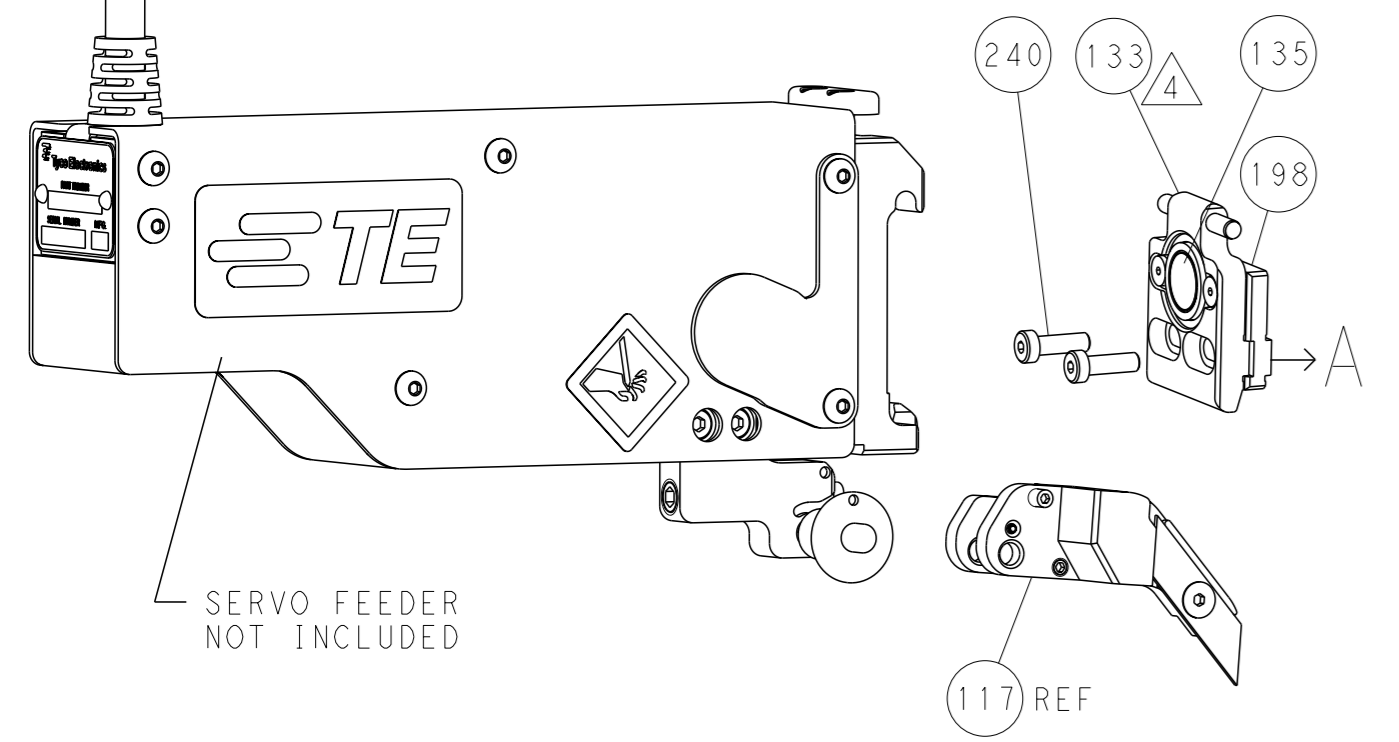

CAM POSITIONS

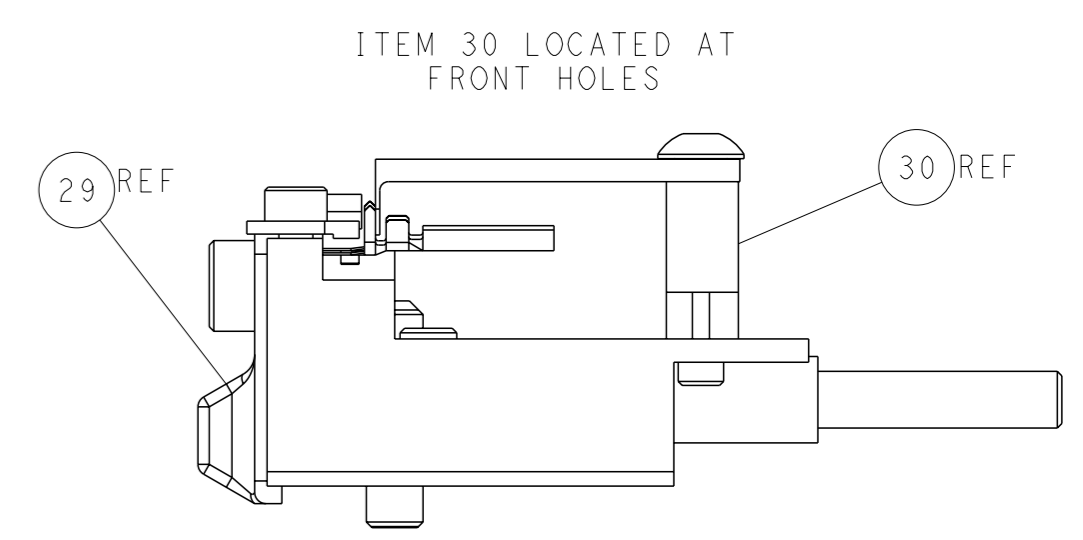
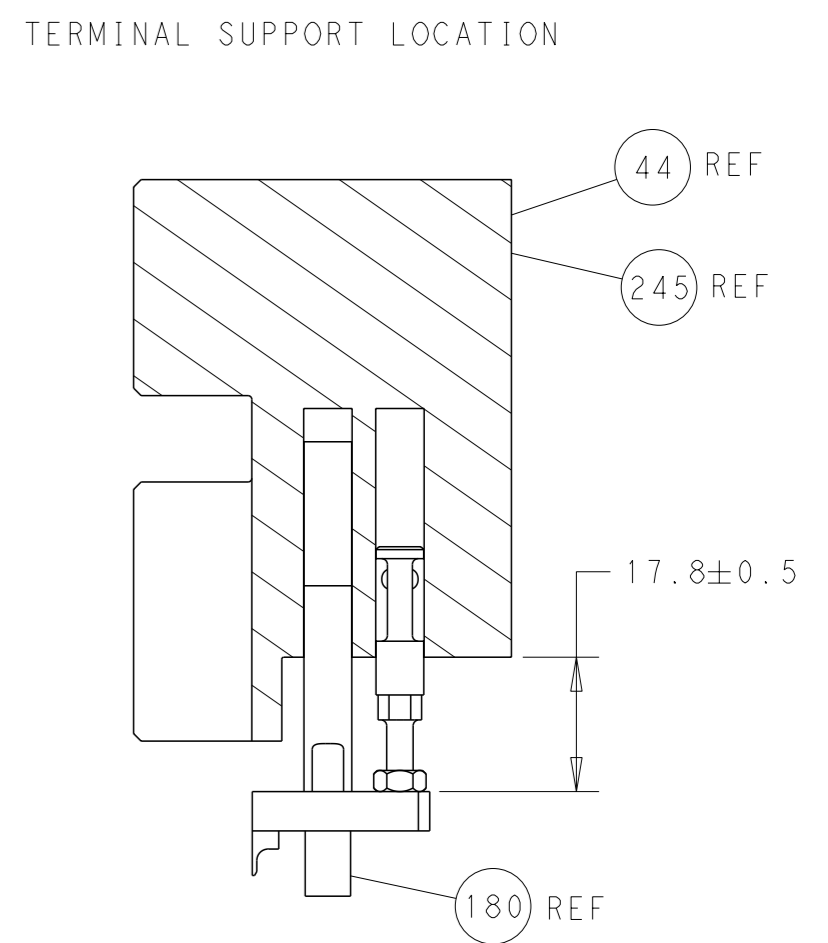
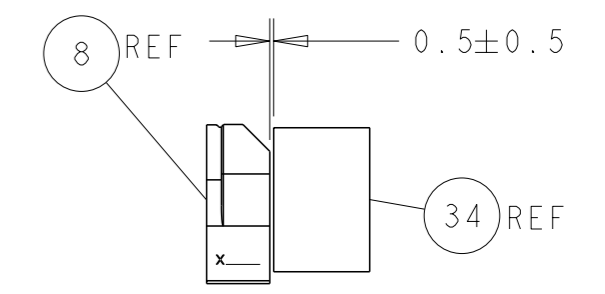
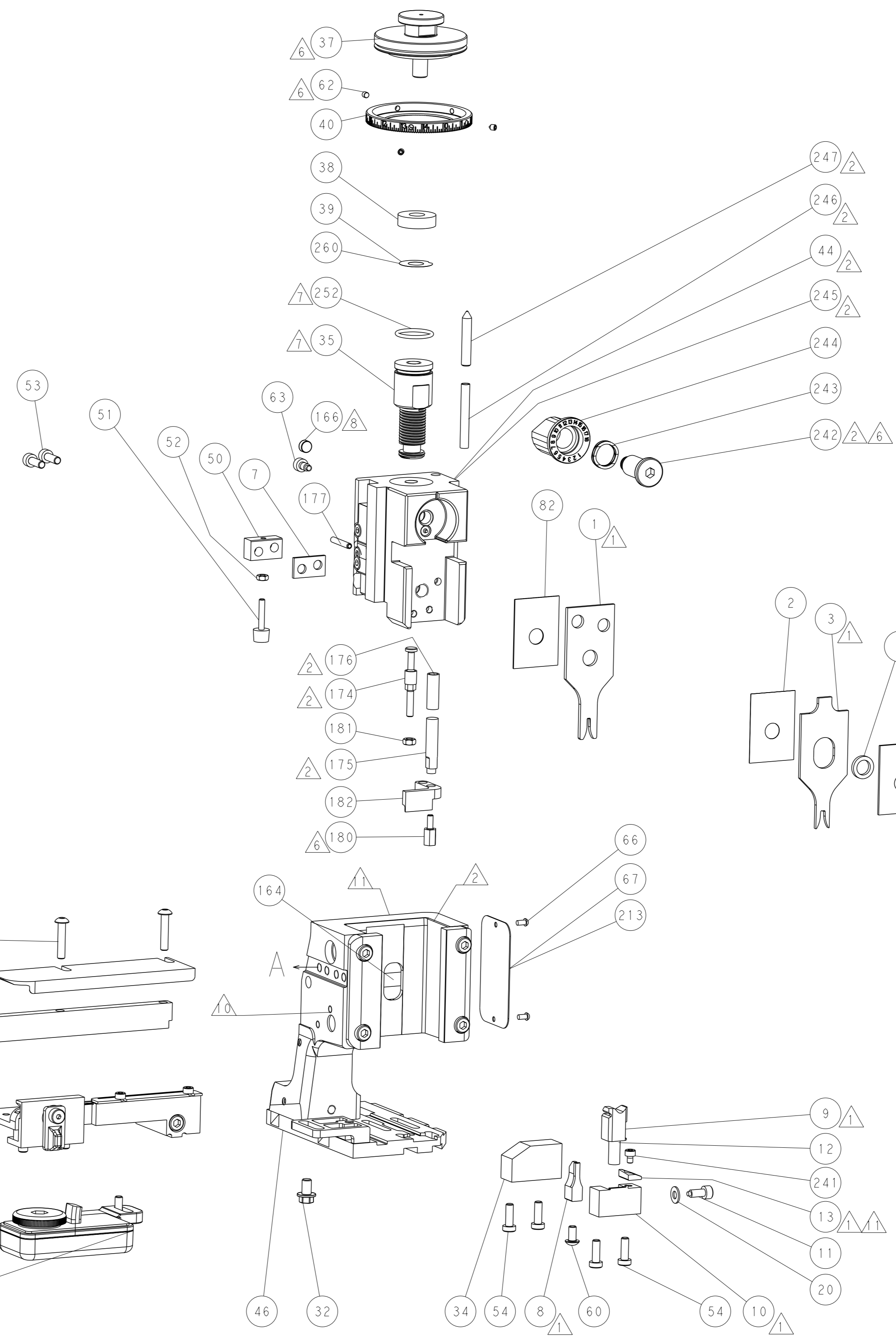
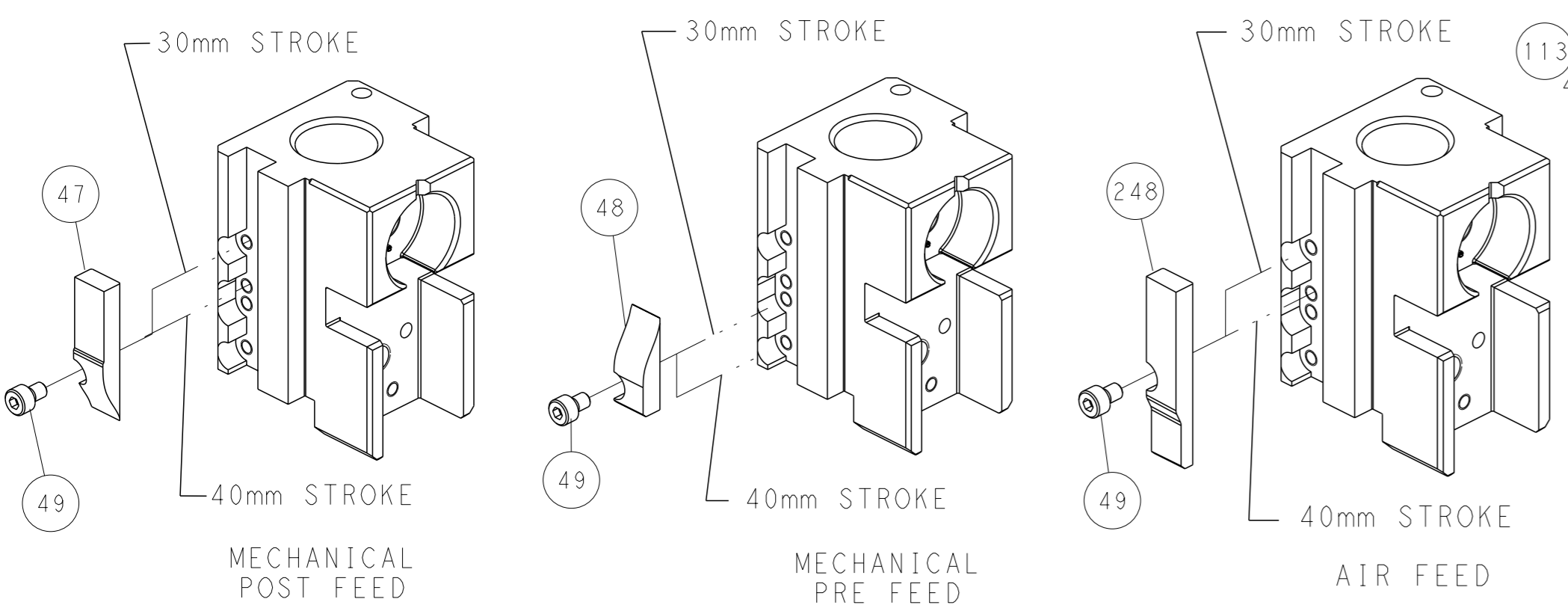

ATLANTIC VERSION
 Shown on sheets 1 of 4 & 2 of 4
 (Pacific version shown on sheets 3 of 4 & 4 of 4)

<small>THE DRAWING IS A CONTROLLED DOCUMENT FOR TYCO ELECTRONICS CORPORATION. IT IS SUBJECT TO CHANGE AND THE CONTROL AND REVISIONS DISPOSITION SHOULD BE CONTACTED FOR THE LATEST REVISION.</small>		OWN: 31MAR2014 CDR: T. ELBIN APVD: D. STOUGH PRODUCT SPEC: - APPLICATION SPEC: - WEIGHT: - MATERIAL: -	SIZE: A1 CAGE CODE: 00779 DRAWING NO: C=2266248 SCALE: 1:2 SHEET: 2 of 4 REV: B1	NAME: Ocean Side Feed Applicator RESTRICTED TO: -
DIMENSIONS: mm TOLERANCES UNLESS OTHERWISE SPECIFIED: 0 PLC ± 1 PLC ± 2 PLC ± 3 PLC ± 4 PLC ± ANGLES ° ±		TE Connectivity Harrisburg, PA 17105-3608 Customer Accessible Production Drawing		

PACIFIC VERSION TERMINATOR INTERFACE ADAPTER	PART NUMBER	REVISION	DESCRIPTION	FEED TYPE	
	2-2266248-1	B	FINE CRIMP HEIGHT ADJUST	MECHANICAL	OBSOLETE
	2-2266248-2	B	FINE CRIMP HEIGHT ADJUST	PNEUMATIC	OBSOLETE
	2-2266248-5	B	FINE CRIMP HEIGHT ADJUST	SERVO LATCH PLATE	OBSOLETE
	2-2266248-7	B	FINE CRIMP HEIGHT ADJUST	NONE	OBSOLETE
	7-2266248-7	A	CRIMP TOOLING KIT	-	

APPLICATOR DATA		
CRIMP	SIZE	TYPE
WIRE	1.57 mm (.062)	F
INSUL	2.79 mm (.110)	F
APPLICATOR INSTRUCTIONS 408-10389		

TERMINAL DATA: TE TERMINAL		TE CRIMP SPECIFICATION	
TERMINAL NAME: MINI UNIVERSAL MATE-N-LOK			
WIRE STRIP LENGTH		INSULATION DIAMETER RANGE	
3.20-3.70 mm (.126-.146 IN)			
TERMINAL APPLICATION SPECIFICATION	(A)114-16017	(A)114-13089	
	(B)114-5050		
TERMINALS APPLIED			
TE TERMINAL	TE TERMINAL	TE TERMINAL	TE TERMINAL
(A) 770903-1	(A) 770904-1	(A) 794137-1	(B) 170360-6
(A) 770903-2	(A) 770904-2	(A) 794137-2	(B) 170362-1
(A) 770903-3	(A) 770904-3	(A) 794137-3	(B) 170362-2
(A) 770903-4	(A) 770904-4	(A) 1-794137-0	(B) 170362-3
(A) 770903-5	(A) 770904-5	(B) 170360-1	(B) 170362-4
(A) 770903-6	(A) 770904-6	(B) 170360-2	(B) 170362-6
(A) 1-770903-0	(A) 1-770904-0	(B) 170360-3	(B) 1-170362-3
(A) 1-770903-1	(A) 1-770904-1	(B) 170360-4	

WIRE SIZE	CRIMP HEIGHT mm [INCH]	CRIMP HEIGHT REFERENCE SETTING
18 AWG	1.07 +/- 0.05 [0.042 +/- .002]	6.7
0.75mm ²	1.04 +/- 0.05 [0.041 +/- .002]	7.0
20 AWG OR 0.50mm ²	0.91 +/- 0.05 [0.036 +/- .002]	8.5
2 X 22 AWG	0.91 +/- 0.05 [0.036 +/- .002]	8.5
22 AWG OR 0.35mm ²	0.81 +/- 0.05 [0.032 +/- .002]	9.5

- 1. RECOMMENDED SPARE PARTS
- 2. GREASE BEARING SURFACES LIGHTLY
- 3. LUBRICATE DAILY PER THE APPLICATOR INSTRUCTION SHEET SUPPLIED WITH THE APPLICATOR.
- 4. APPLICATOR SPECIFIC DATA TO BE ENTERED INTO BLANK MEMORY CHIP AT ASSEMBLY. SEE BELOW FOR PART NUMBER:
MECHANICAL FEED WITH "SMART APPLICATOR" CONVERSION: 8-2266248-4
PNEUMATIC FEED WITH "SMART APPLICATOR" CONVERSION: 8-2266248-4
SERVO FEED WITH "FINE CRIMP HEIGHT ADJUST": 8-2266248-5
- 5. ADJUSTMENT OF THE STRIPPER MAY BE REQUIRED WHEN MOVING THE APPLICATOR BETWEEN BENCH AND LEADMAKER APPLICATIONS.
- 6. APPLY PART NUMBER 1-23419-5 LOCTITE TO THREADS OF ITEMS 62 & 180. APPLY PART NUMBER 2-23419-6 LOCTITE TO THREADS OF ITEM 242.
- 7. GREASE THREADS, GROOVE AND O-RING ON ITEMS 139 & 152.
- 8. MAGNET MUST BE ORIENTED CORRECTLY IN ORDER TO PROPERLY ACTUATE THE COUNTER.
- 9. CRIMP HEIGHT REFERENCE SETTING WAS THE SETTING USED WHEN THE APPLICATOR WAS QUALIFIED AT THE FACTORY. ADJUSTMENT MAY BE NECESSARY WHEN RUNNING APPLICATOR IN THE FIELD.
- 10. SPARE FEED CAM STORAGE LOCATION REFER TO INSTRUCTION SHEET FOR ADDITIONAL INFORMATION.
- 11. TO CONVERT THE APPLICATOR TO A NON-CARRIER CUTTING STYLE, REMOVE ITEM 13 AND ATTACH TO THE LOCATION ON BACK SIDE OF THE HOUSING. REFER TO INSTRUCTION SHEET FOR ADDITIONAL INFORMATION.

TERMINAL PART NUMBER	INSULATION RANGE
770903	1.5-2.4mm
770904	
170362	
170360	
794137	1.5-2.8mm

- 13. THIS APPLICATOR IS SPECIFIC FOR USE IN A STRIPPER CRIMPER TERMINATING UNIT.
- 14. 114-13089 IS FOR SEAL APPLICATION ONLY. "F" TYPE INSULATION CRIMP IS USED AT A REDUCED INSULATION PAD SETTING FOR SEAL APPLICATIONS.
- 15. TERMINAL LUBRICANT IS RECOMMENDED.

-	1	1	1	1	2119782-1	FINE ADJUST HEAD ASM, PACIFIC STYLE	251
-	-	-	1	-	2119640-1	PUSH ROD, AIR FEED	250
-	-	-	1	-	2079988-1	BUSHING, LCH5-12, MISUMI	249
-	1	1	1	1	1-22279-3	SPRING, COMPRESSION	246
-	1	1	1	1	2119082-9	CAM, SNAIL, INSULATION ADJUSTMENT	244
-77	-27	-25	-22	-21	PART NO	DESCRIPTION	ITEM NO

PACIFIC VERSION
Shown on sheets 3 of 4 & 4 of 4
(Atlantic version shown on sheets 1 of 4 & 2 of 4)

SET UP GAUGE	LOC	DIST	REVISIONS					
2119599-1	A	66	P	LYR	DESCRIPTION	DATE	OWN	APVD
			-	-	SEE SHEET 1	-	-	-

6	-	1	1	1	1	2079764-1	WASHER, WAVE SPRING, CREST-TO-CREST	243
	-	1	1	1	1	2119083-1	RETAINER, INSULATION DIAL	242
	-	1	1	1	1	7-18023-7	SCR, SKT HD CAP M3 X 4.0	241
	-	-	2	-	-	2168400-6	SHCS, LOW HEAD, RoHS, M5 X 16	240
	-	-	-	-	1	2119580-1	MECHANICAL FEED ASSEMBLY	239
	-	-	-	1	-	2063440-1	AIR FEED MODULE	238
	-	-	1	-	-	2119740-2	TAG, IDENTIFICATION	213
	-	-	1	-	-	1901094-3	SPACER, FEEDER	198
	-	1	1	1	1	4-1722335-3	STRIPPER, SIDE FEED	182
6	-	1	1	1	1	1-5018030-0	NUT, HEX, REG, RoHS, M3.5	181
	-	1	1	1	1	1-1752354-9	STANDOFF, HOLD-DOWN	180
	-	1	1	1	1	993111-1	PIN, SLOTTED SPRING 3.0 X 20.0	177
	-	1	1	1	1	5-22280-0	SPRING, COMPRESSION	176
	-	1	1	1	1	1752353-3	GUIDE PIN, HOLDDOWN	175
	-	1	1	1	1	1901680-2	GUIDE PIN, HOLDDOWN	174
	-	-	-	2	-	21045-3	RING, RETAIN, EXTERN, 3/16 CRESCENT	172
	-	1	1	1	1	994969-1	MAGNET, RARE EARTH HIGH ENERGY	166
	-	REF	REF	REF	REF	994970-2	COUNTER, MAGNETIC	164
	-	-	-	1	-	240638-1	SPRING, FEED FINGER	163
	-	1	1	1	1	8-21084-1	O-RING, .801 ID, .070 DIA. MAT.	152
	-	-	-	1	-	2119641-2	FEED CAM, AIR FEED	151
	-	1	1	1	1	2119798-2	DETENT PIN	145
	-	1	1	1	1	2079383-8	SCR, BHSC, RoHS (M4 X 16)	144
	-	4	4	4	4	2168400-5	SHCS, LOW HEAD, RoHS, M4 X 20	143
	-	-	-	-	1	2119653-2	FEED CAM, POST FEED	142
	-	1	1	1	1	2-2119656-2	APPLICATOR BASIC ASSEMBLY, SF	141
	-	1	1	1	1	2119650-1	RAM, ASIAN STYLE, SIDE FEED	140
	-	1	1	1	1	2119092-2	BOLT, ADJUSTMENT	139
	-	-	-	1	-	3-23627-7	PIN, RETAIN, GRVD, 3/16 X .854	137
	-	-	-	1	-	2119799-1	HOLDER, FEED FINGER, AF	136
	-	-	REF	-	-	SEE NOTE 4	MEMORY CHIP, PROGRAMMED	135
	-	-	1	-	-	1633743-1	SERVO FEED LATCH ASM	133
	-	-	REF	-	-	2119944-1	FEED FINGER ASSEMBLY, SF	117
15	-	1	1	1	1	2119955-1	ASSY, LUBRICATOR, SIDE FEED	113
	-	1	1	1	1	455888-5	SPACER, CRIMPER	82
	-	1	1	1	1	2119956-1	DOCUMENTATION PACKAGE	71
	-	1	-	1	1	2119740-1	TAG, IDENTIFICATION	67
	-	2	2	2	2	2168078-1	SCREW, DRIVE, RH, RoHS, 2 x .188	66
	-	1	1	1	1	2119793-1	LIMITER, ADJUSTMENT BOLT	63
6	-	3	3	3	3	992763-5	SCR, SET, SOC, CONE PNT, M3 X 4.0	62
	-	-	-	1	1	5-18022-5	SCR, HEX HD CAP, M4 X 6.0	59
	-	-	-	1	1	1338685-1	PAWL, FEED	56
	-	2	2	2	2	2168083-3	SCR, SKT HD CAP, RoHS, M4 X 12.0	53
	-	1	1	1	1	5018030-1	NUT, HEX, REG, RoHS, M3	52
	-	1	1	1	1	811242-5	BUMPER, HOLD DOWN	51
	-	1	1	1	1	690753-2	SPACER, TONKER	50
	-	-	-	1	2	18023-9	SCR, SKT HD CAP M4 X 6.0	49
	-	-	-	-	1	2119652-1	FEED CAM, PRE FEED	48
	-	1	1	1	1	2079383-7	SCR, BHSC, RoHS (M8 X 25)	41
	-	1	1	1	1	2119645-1	DISC, NUMBERED FA WIRE ADJUSTMENT	40
	-	1	1	1	1	2119957-1	APPLICATOR SHIM PACK	39
	-	1	1	1	1	2119644-1	RAM WASHER, PRECISION	38
	-	1	1	1	1	1752356-6	SUPPORT, TERMINAL	34
	-	2	2	2	2	2079383-5	SCR, BHSC, RoHS (M4 X 20)	33
	-	1	1	1	1	2161328-1	HEX HEAD, FLANGED, M5 X 8mm LONG	32
	-	1	1	1	1	1320908-6	SPACER, STRIP GUIDE	30
	-	1	1	1	1	2119959-2	ASSEMBLY, STRIP GUIDE	29
	-	1	1	1	1	1-455888-0	SPACER, CRIMPER	28
	-	1	1	1	1	1320928-2	STRIP GUIDE	24
	-	1	1	1	1	1-18028-2	WASHER, FLAT, REG M4	20
1	-	1	1	1	1	2119806-1	INSERT, SHEAR	13
	-	1	1	1	1	3-22280-3	SPRING, COMPRESSION	12
	-	1	1	1	1	1-356885-4	STOP, SHEAR	11
1	-	1	1	1	1	2119805-1	SHEAR HOLDER, FRONT	10
1	-	1	1	1	1	1803095-1	FLOATING SHEAR, FRONT	9
1	1	1	1	1	1	1338691-1	ANVIL, COMBINATION .062	8
	-	1	1	1	1	3-240641-3	SPACER	7
	-	-	-	-	-	-	-	6
	-	1	1	1	1	2119757-2	DEPRESSOR, SHEAR	5
	-	1	1	1	1	2-238011-2	BLOCK, CRIMPER SPACER	4
1	1	1	1	1	1	2-2119582-1	CRIMPER, INSULATION F PREMIUM	3
	-	1	1	1	1	455888-1	SPACER, CRIMPER	2
1	1	1	1	1	1	1-456403-6	CRIMPER, WIRE PREMIUM	1
	-77	-27	-25	-22	-21	PART NO	DESCRIPTION	ITEM NO

DIMENSIONS:		TOLERANCES UNLESS OTHERWISE SPECIFIED:		OWN		DATE	
mm		0 PLC ±		31MAR2014		31MAR2014	
		1 PLC ±		T. ELBIN		NAME	
		2 PLC ±		D. STOUGH		Ocean Side Feed	
		3 PLC ±		PRODUCT SPEC		Applicator	
		4 PLC ±		APPLICATION SPEC		SIZE	
		5 PLC ±		WEIGHT		CAGE CODE	
		ANGLES FINISH		A1		DRAWING NO	
				Customer Accessible Production Drawing		00779	
				SCALE		3 of 4	
				1:2		REV B1	

