

2008/05/02 02:29:36 CAROL TRIBBLE

DRAWING FOR REFERENCE: This is subject to change without notice

TO  
Q

COUNT	DESCRIPTION OF REVISIONS	BY	CHKD	DATE	COUNT	DESCRIPTION OF REVISIONS	BY	CHKD	DATE
△					△				
△					△				
APPLICABLE STANDARD		EIAJ RC-5240							
RATING	OPERATING TEMPERATURE RANGE	-40 °C TO +85 °C			STORAGE TEMPERATURE RANGE	-40 °C TO +85 °C			
	VOLTAGE	AC 50V			OPERATING HUMIDITY RANGE	5 % TO 85 %			
	CURRENT	0.3 A			APPLICABLE CABLE	-			
<b>SPECIFICATIONS</b>									
ITEM		TEST METHOD			REQUIREMENTS			QT	AT
<b>CONSTRUCTION</b>									
GENERAL EXAMINATION		VISUALLY AND BY MEASURING INSTRUMENT.			ACCORDING TO DRAWING.			X	X
MARKING		CONFIRMED VISUALLY.						X	X
<b>ELECTRIC CHARACTERISTICS</b>									
CONTACT RESISTANCE		100 mA (DC OR 1000 Hz).			50 mΩ MAX.			X	-
INSULATION RESISTANCE		250 V DC.			100 MΩ MIN.			X	-
VOLTAGE PROOF		250 V AC FOR 1 min.			NO FLASHOVER OR BREAKDOWN.			X	X
<b>MECHANICAL CHARACTERISTICS</b>									
INSERTION AND WITHDRAWAL FORCES		MEASURED BY APPLICABLE CONNECTOR.			INSERTION FORCE 24.5 N MAX. WITHDRAWAL FORCE 2.5 N MIN.			X	-
MECHANICAL OPERATION		10000 TIMES INSERTIONS AND EXTRACTIONS.			① CONTACT RESISTANCE : 100 mΩ MAX. ② INSERTION FORCE 24.5 N MAX. WITHDRAWAL FORCE 1.9 N MIN. ③ NO DAMAGE, CRACK AND LOOSENESS, OF PARTS.			X	-
VIBRATION		FREQUENCY 10 TO 55 Hz, SINGLE AMPLITUDE 0.75 mm, AT 2 h, FOR 3 DIRECTIONS, TOTAL 6 h.			① NO ELECTRICAL DISCONTINUITY OF 1 μs. ② NO DAMAGE, CRACK AND LOOSENESS, OF PARTS.			X	-
SHOCK		490 m/s <sup>2</sup> DIRECTIONS OF PULSE 11 ms AT 3 TIMES FOR 6 DIRECTIONS, TOTAL 18 TIMES.						X	-
<b>ENVIRONMENTAL CHARACTERISTICS</b>									
RAPID CHANGE OF TEMPERATURE		TEMPERATURE -40 → 25 → 85 → 25 °C TIME 30 → 2 TO 3 → 30 → 2 TO 3 min UNDER 10 CYCLES.			① CONTACT RESISTANCE : 100 mΩ MAX. ② NO DAMAGE, CRACK AND LOOSENESS, OF PARTS.			X	-
DAMP HEAT (STEADY STATE)		EXPOSED AT 40±3 °C, 90~95 %, 96 h (FOR 4 DAYS).			① CONTACT RESISTANCE : 100 mΩ MAX. ② INSULATION RESISTANCE : 10 MΩ MIN. ③ NO FLASHOVER OR BREAKDOWN. ④ NO DAMAGE, CRACK AND LOOSENESS, OF PARTS.			X	-
DRY HEAT		EXPOSED AT +85±2 °C, 96±4 h.			① CONTACT RESISTANCE : 100 mΩ MAX. ② NO DAMAGE, CRACK AND LOOSENESS, OF PARTS.			X	-
COLD		EXPOSED AT -40±3 °C, 96±4 h.			① CONTACT RESISTANCE : 100 mΩ MAX. ② NO DAMAGE, CRACK AND LOOSENESS, OF PARTS.			X	-
CORROSION SALT MIST		EXPOSED IN 5±1% SALT WATER, 35±3 °C FOR 48 ±4 h.			① CONTACT RESISTANCE : 100 mΩ MAX. ② NO HEAVY CORROSION.			X	-
REMARKS					DRAWN	DESIGNED	CHECKED	APPROVED	RELEASED
Unless otherwise specified, refer to JIS C 5402.					M. Shingama 05.9.1	M. Shingama 05.9.1	K. Schikawa 05.9.2	 05.9.2	
Note QT:Qualification Test AT:Assurance Test X:Applicable Test									
<b>HRS</b> HIROSE ELECTRIC CO., LTD.					SPECIFICATION SHEET			PART NO. MQ212B-10P	
CODE NO.(OLD)		DRAWING NO.			CODE NO.			1/2	
CL		ELC4-125478			CL206-2506-5				

TO
Q

SPECIFICATIONS				
ITEM	TEST METHOD	REQUIREMENTS	QT	AT
SOLDERABILITY	SOLERRING POINT OF CONTACTS IMMERSION IN SOLDER BATH OF 235±10°C, 2±0.5 sec.	SOLDERING POINT OF CONTACTS IMMERSION IN SOLDER, 90% MIN.	×	—
RESISTANCE TO SOLDERING HEAT	MOLTEN-SDDER TEMPERATURE: 260±5°C. IMMERSION FURABILITY PER LOCATION: 2± 1 sec.	NO DAMAGE, CRACK AND LOOSENESS, OF PARTS.	×	—

REMARKS	DRAWN	DESIGNED	CHECKED	APPROVED	RELEASED
	<i>M. Shimegama</i> 05.9.1	<i>M. Shimegama</i> 05.9.1	<i>J. Chikawa</i> 05.9.2	<i>[Signature]</i> 05.9.2	

Note QT:Qualification Test AT:Assurance Test ×:Applicable Test

<b>HRS</b> HIROSE ELECTRIC CO., LTD.	SPECIFICATION SHEET	PART NO. MQ212B-10P
CODE NO.(OLD) CL	DRAWING NO. ELC4-125478	CODE NO. CL206-2506-5
		2/2

TO
Q

COUNT	DESCRIPTION OF REVISIONS	BY	CHKD	DATE	COUNT	DESCRIPTION OF REVISIONS	BY	CHKD	DATE

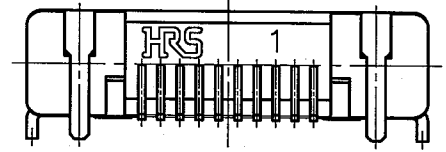
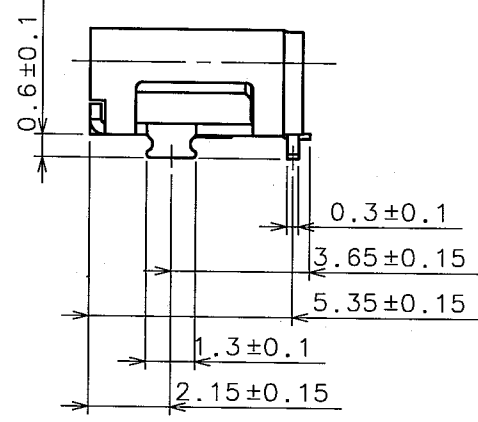
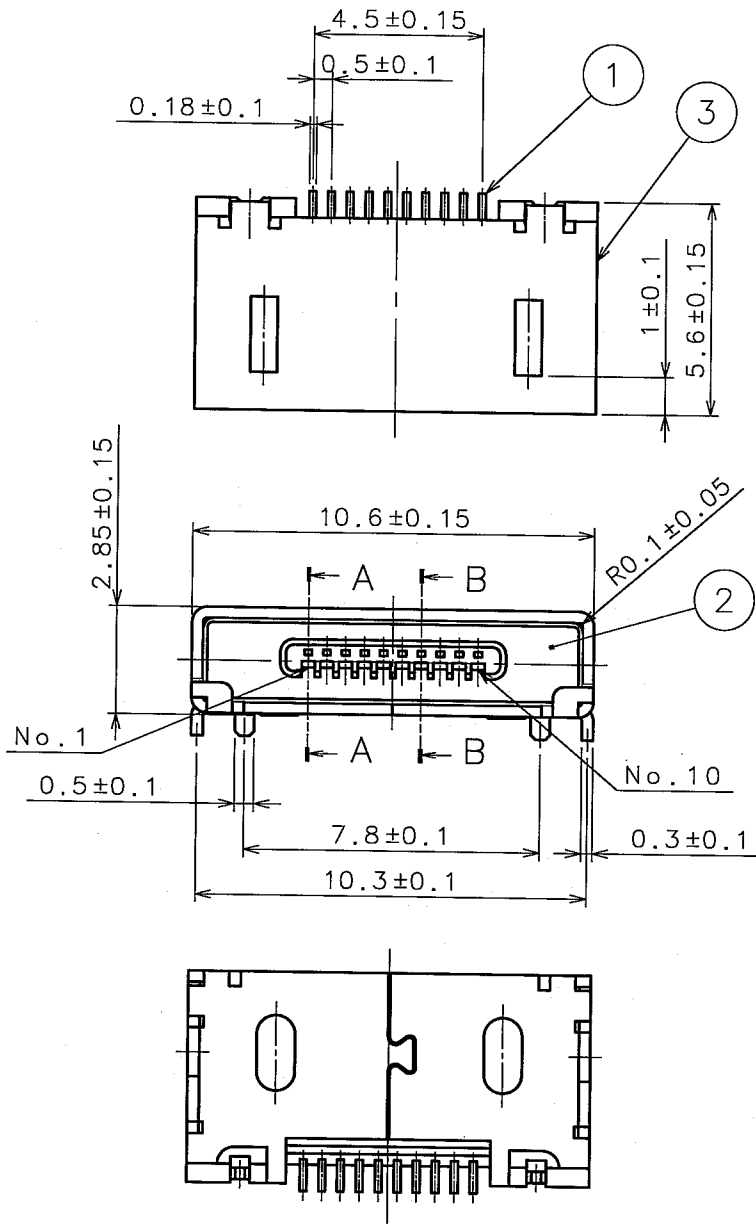

RECOMMENDED PC BOARD PATTERN

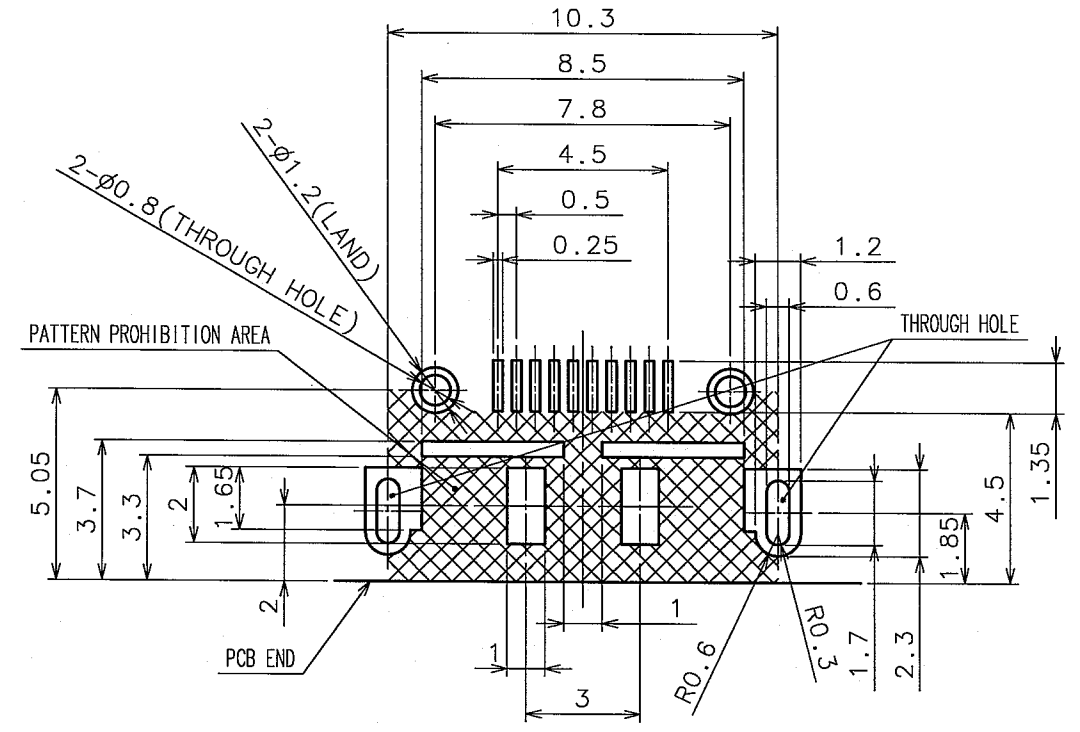

A-A (10:1)  
(CONTACT No. 1, 10)

B-B (10:1)  
(CONTACT No. 2~9)

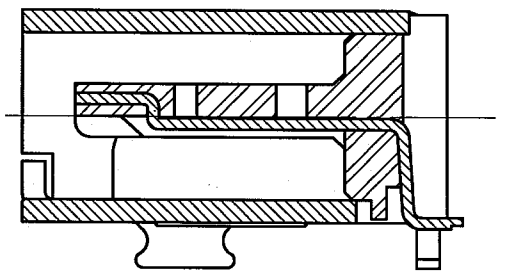
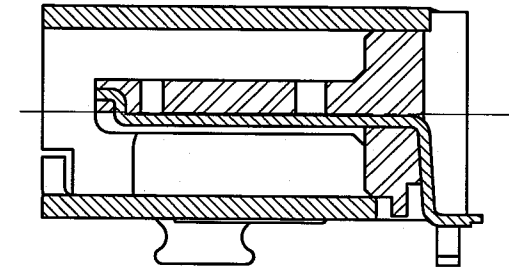

NOTE 1 PER REL: 1500 PIECES.  
2 CO-PLANARITY TO BE 0.1mm MAX.

UNEINDING DIRECTION

FIGURE FOR PACKING

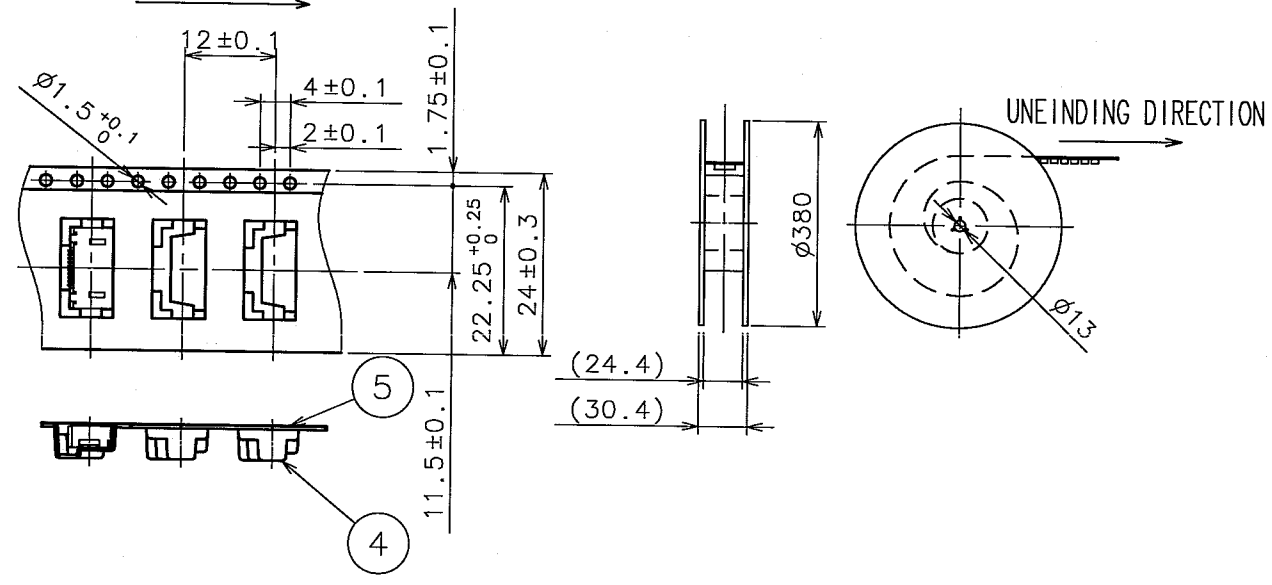

2	LCP	UL94V-0 (BLACK)	5	PS	
1	PHOSPHOR BRONZE	UNDER PLATING: NICKEL 2μm MIN CONTACT AREA: GOLD 0.2μm MIN LEAD AREA: GOLD FLASH	4	PS	
NO.	MATERIAL	FINISH, REMARKS	NO.	MATERIAL	FINISH, REMARKS
3	PHOSPHOR BRONZE	UNDER PLATING: NICKEL 1μm MIN MOUNTING AREA: TIN 1μm MIN			

CODE NO. (OLD)	DRAWN	DESIGNED	CHECKED	APPROVED	RELEASED
	<i>M. Shimoyama</i>	<i>M. Shimoyama</i>	<i>K. Shihara</i>	<i>[Signature]</i>	
	05.9.1	05.9.1	05.9.2	05.9.2	
SCALE	DRAWING NO.		PART NO.		
5 : 1	EDC3-125478		MQ212B-10P		
UNITS	CODE NO.				
mm	HRS HIROSE ELECTRIC CO., LTD		CL206-2506-5		