

DATE	REV	ECN	APP'D. BY
09/30/22	AO	12050	GWL
11/9/2022	A1	12071	GWL

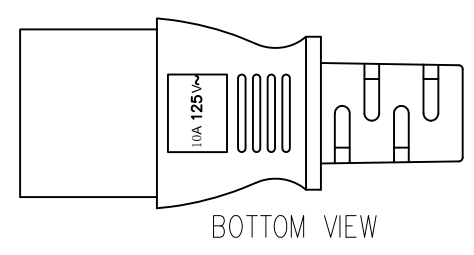

P1: cULus E520671-VN
350-172

P2: cULus E520671-VN
350-181

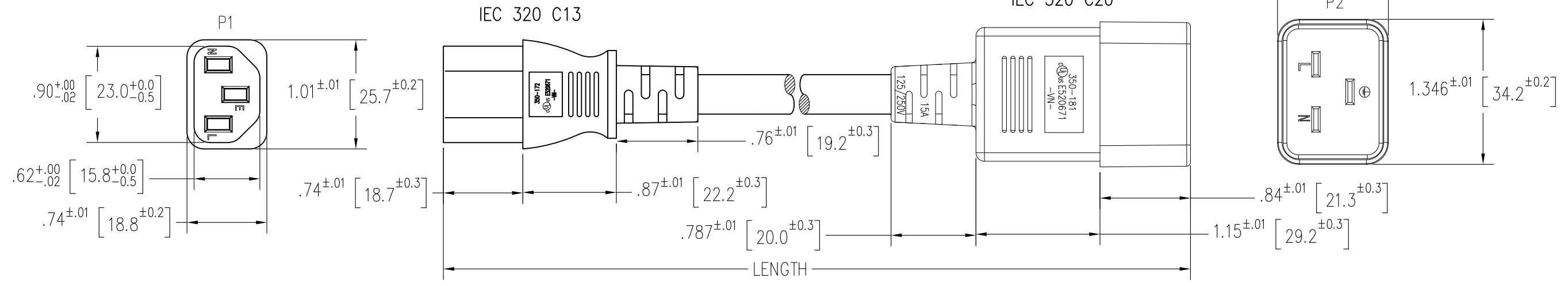
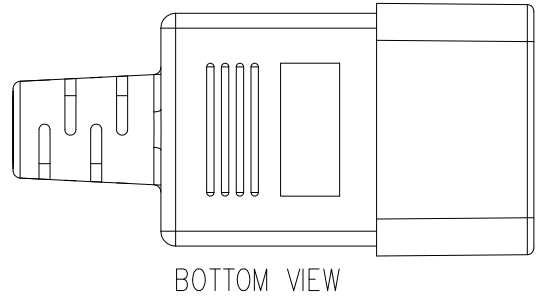

- NOTES:
- SPECIFICATIONS:
RATING: 15A 250V AC
CABLE TYPE: UL SJT 14AWG 3C, OD 9.3mm COLOR (SEE P/N KEY)
CABLE MARKING:
(UL) SJT 3/C 14AWG (2.084MM) ² VW-1 105°C 300V E204978
C(UL) SJT 2.08MM ²(14 AWG) FT2 105°C 300V E204978
 - END "P1": IEC 320 C13, MOLDED PVC 35P, COLOR (SEE P/N KEY)
END "P2": IEC 320 C20, MOLDED PVC 35P, COLOR (SEE P/N KEY)
 - ALL RELEVANT MATERIALS ARE COMPLIANT WITH RoHS DIRECTIVE.
 - APPROVALS: UL cUL
 - TESTING:
 - 100% CONTINUITY/SHORT
 - HIPOT INTERNAL 2KV LASTING 1 SEC;
EXTERNAL 2.5 KV. LASTING 1 SEC
 - OPERATING TEMPERATURE: -4° F (-20° C) TO 140° F (60° C)
 - HUMIDITY RANGE 10-85% RH

P/N Key:

PC-BC K XXX X

Length

002 F = 2 Ft
003 F = 3 Ft
005 F = 5 Ft
006 F = 6 Ft
010 F = 10 Ft

Color

K = Black
R = Red
N = Green
E = Blue

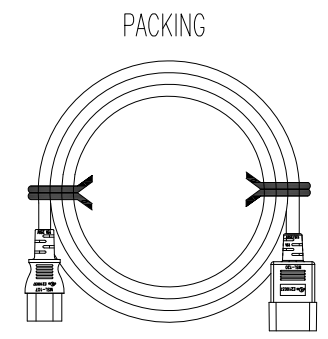

THIRD ANGLE PROJECTION

DRAWING IS SUBJECT TO CHANGE WITHOUT NOTICE

Cable Length Unless Other Spec.
Tolerances:
0 ~ 3.3 Ft [1M] ± .79 IN [20mm]
3.4 Ft [1.1M] ~ 5 Ft [1.5M] ± .98 IN [25mm]
5.1 Ft [1.6M] ~ 6.9 Ft [2M] ± 1.2 IN [30mm]
7.0 Ft [2.1M] ~ † ± 1.6 IN [40mm]
DO NOT SCALE DRAWING

SHEET NO. 1 OF 1



11118 Susquehanna Trail South
Glen Rock, PA 17327-9199
(717) 235-7512
<http://www.stewartconnector.com>

TITLE: POWER SUPPLY CORDS IEC 320 C13 TO IEC 320 C20

DRN BY: GWL	DATE: 09/08/2022
APPD BY: JME	DATE: 09/30/2022
DWG NO: CT999277	REV: A1

THIS DRAWING AND THE SUBJECT MATTER SHOWN THEREON ARE CONFIDENTIAL AND THE PROPRIETARY PROPERTY OF STEWART CONNECTOR AND SHALL NOT BE REPRODUCED, COPIED, OR USED IN ANY MANNER WITHOUT PRIOR WRITTEN CONSENT OF STEWART CONNECTOR. ONE OR MORE U.S. PATENTS MAY APPLY TO THIS PRODUCT. FOR DETAILS, PLEASE VISIT: [HTTP://BELFUSE.COM/STEWART/STEWART_PATENTS/](http://BELFUSE.COM/STEWART/STEWART_PATENTS/)