

LT3980EMSE  
2A, 58V Step-Down Switching Regulator with 75uA  
Quiescent Current

## DESCRIPTION

Demonstration circuit 1476A is a 2A, 58V Step-Down Switching Regulator with 75uA Quiescent Current featuring the LT3980EMSE. The demo board is designed for 5V output from a 6.8V to 58V input with transient up to 80V. The wide input range of the LT3980EMSE allows a variety of input sources. The typical sources are automotive batteries, wall adaptors and industrial supplies. The switching frequency can be programmed either via oscillator resistor or external clock. The modes of operation (Burst Mode or synchronization) are jumper selectable. The Burst Mode operation increases the efficiency at light loads.

The LT3980EMSE current mode control scheme creates fast transient response and good loop stability. The gate drive of the internal switch is boosted to a voltage that is higher than  $V_{in}$  to ensure saturation of the switch. The LT3980EMSE's integrated boost diode reduces the parts

count. The RUN/SS pin can be used to set the part in micropower shutdown mode, reducing the supply current to less than 1uA. The RUN/SS pin can also be used to program soft start. In this mode, the RUN/SS pin is driven through an external RC filter to create a voltage ramp on this pin. The soft start function reduces the input current surge during start-up.

The LT3980EMSE datasheet gives a complete description of the part, operation and application information. The datasheet must be read in conjunction with this quick start guide for demo circuit 1476A.

**Design files for this circuit board are available. Call the LTC factory.**

 LTM, LTC, LT and  $\mu$ Module are registered trademarks of Linear Technology Corporation. All other trademarks are the property of their respective owners.

## PERFORMANCE SUMMARY

 Specifications are at  $T_A = 25^\circ\text{C}$ 

PARAMETER FOR BUCK REGULATOR	CONDITION	VALUE
Minimum Input Voltage		6.8V
Maximum Input Voltage		58V
Output Voltage $V_{OUT}$		5V +/- 5%
Maximum Output Current		2A
Typical Switching Frequency		650kHz

## QUICK START PROCEDURE

Demonstration circuit 1476A is easy to set up to evaluate the performance of the LT3980EMSE. Refer to Figure 1 for proper measurement equipment setup and follow the procedure below:

**NOTE.** When measuring the input or output voltage ripple, care must be taken to avoid a long ground lead on the oscilloscope probe. Measure the input or output voltage ripple by touching the probe tip directly across the  $V_{in}$  or  $V_{out}$  and GND terminals. See Figure 2 for proper scope probe technique.

# LT3980EMSE

- Place  
JP1 = ON  
JP2 = BURST MODE
- With power off, connect the input power supply to Vin and GND.
- Turn on the power at the input.
- Check for the proper output voltage.
- Once the proper output voltage is established, adjust the load within the operating range and observe the output voltage regulation, ripple voltage, efficiency and other parameters.
- An external clock can be added to the SYNC pin when SYNC function is used (JP2=SYNC). See synchronization section in the datasheet for details.

**NOTE.** If there is no output, temporarily disconnect the load to make sure that the load is not set too high.

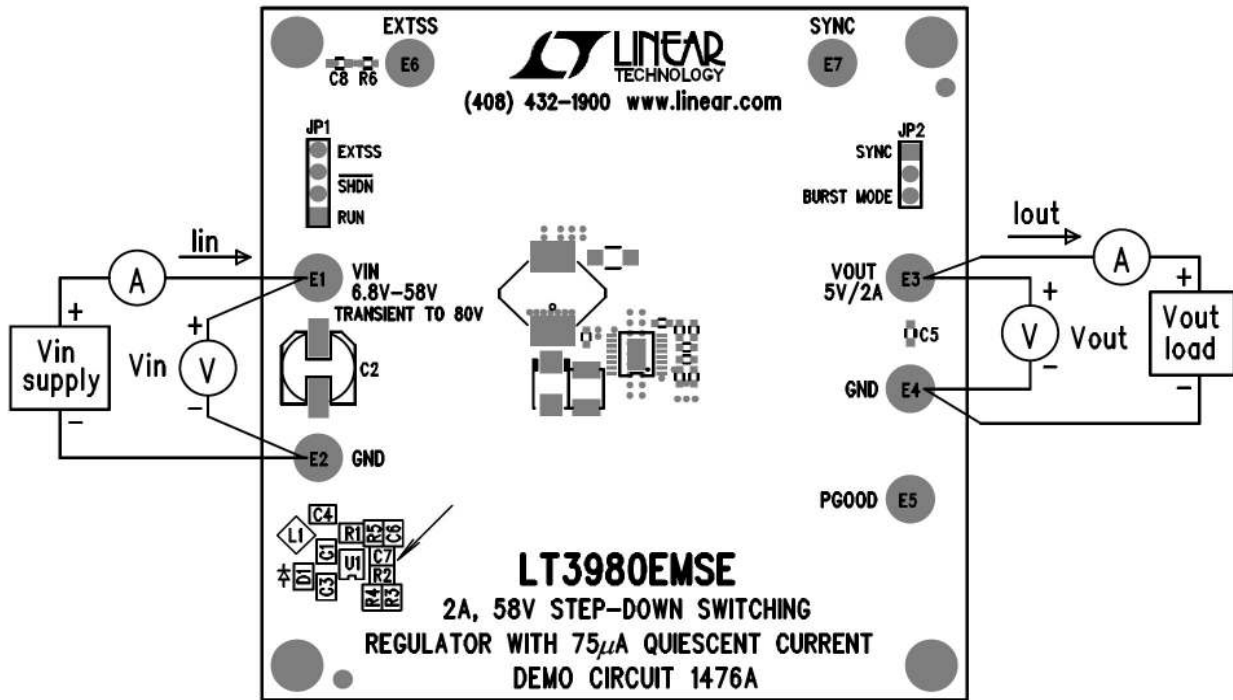

Figure 1. Proper Measurement Equipment Setup

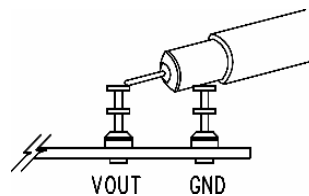
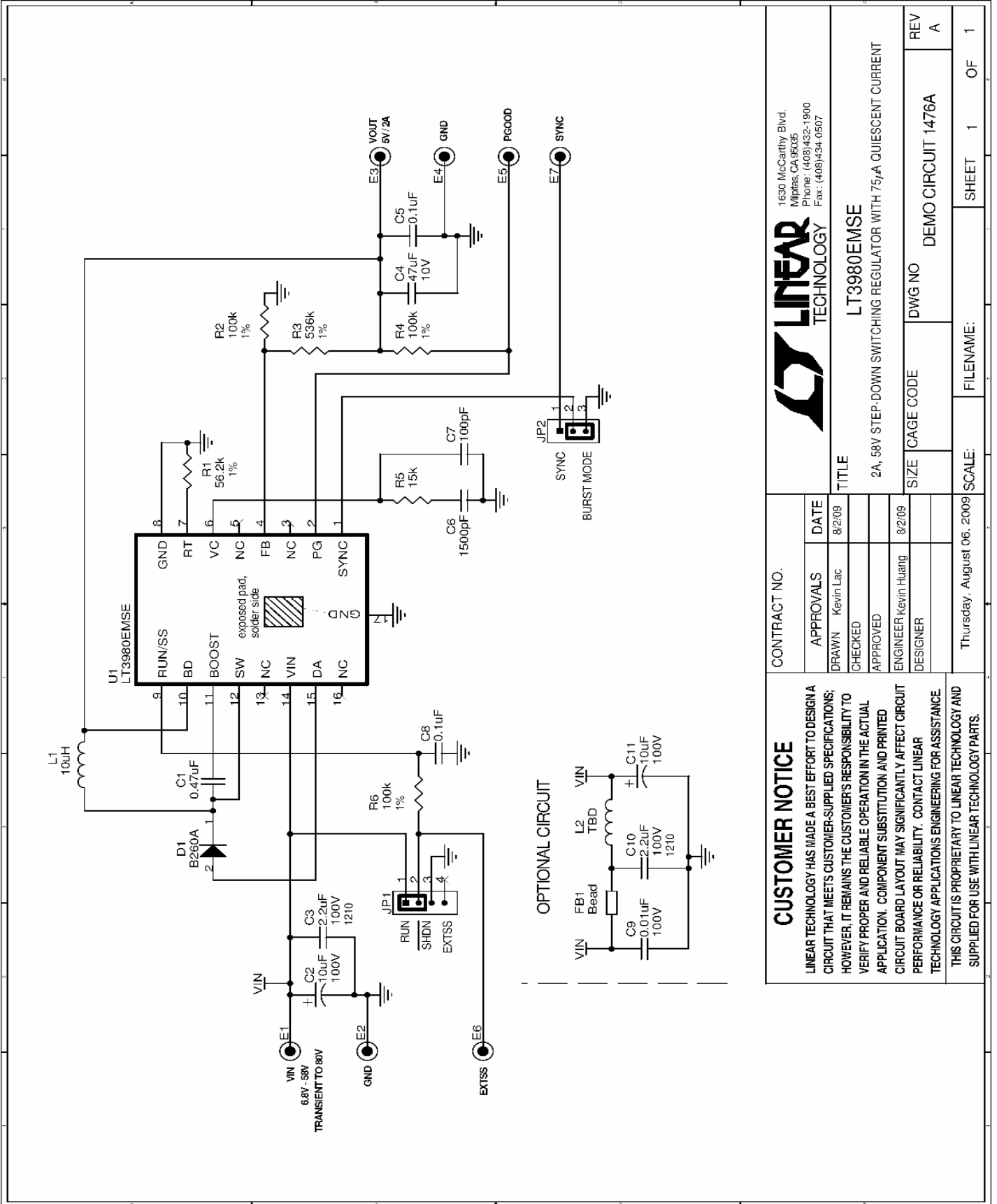

Figure 2. Measuring Input or Output Ripple



<b>CONTRACT NO.</b>		<b>APPROVALS</b>		<b>DATE</b>	
		DRAWN Kevin Lac		8/2/09	
		CHECKED			
		APPROVED			
		ENGINEER Kevin Huang		8/2/09	
		DESIGNER			
		Thursday, August 06, 2009		SCALE:	
		FILENAME:		SHEET 1 OF 1	
<b>CUSTOMER NOTICE</b>		<p>LINEAR TECHNOLOGY HAS MADE A BEST EFFORT TO DESIGN A CIRCUIT THAT MEETS CUSTOMER-SUPPLIED SPECIFICATIONS; HOWEVER, IT REMAINS THE CUSTOMER'S RESPONSIBILITY TO VERIFY PROPER AND RELIABLE OPERATION IN THE ACTUAL APPLICATION. COMPONENT SUBSTITUTION AND PRINTED CIRCUIT BOARD LAYOUT MAY SIGNIFICANTLY AFFECT CIRCUIT PERFORMANCE OR RELIABILITY. CONTACT LINEAR TECHNOLOGY APPLICATIONS ENGINEERING FOR ASSISTANCE.</p> <p>THIS CIRCUIT IS PROPRIETARY TO LINEAR TECHNOLOGY AND SUPPLIED FOR USE WITH LINEAR TECHNOLOGY PARTS.</p>			
<b>LINEAR TECHNOLOGY</b>		1630 McCarthy Blvd. Milpitas, CA 95035 Phone: (408)432-1900 Fax: (408)434-0507		<b>LT3980EMSE</b>	
<b>TITLE</b>		2A, 58V STEP-DOWN SWITCHING REGULATOR WITH 75µA QUIESCENT CURRENT			
<b>SIZE</b>		<b>CAGE CODE</b>		<b>DWG NO</b>	
				DEMO CIRCUIT 1476A	
				<b>REV</b>	
				A	