

Taz 6 Enclosure



This work is licensed under a Creative Commons Attribution-ShareAlike 4.0 International License. Created by David Randolph and printedsolid.com



What's Included?

2	Part A: Front and rear panel	1	Part M: Front Middle
2	Part B: Top mount with holes	1	Part N: Front Shelf
1	Part C: Rear Left Stiffener	1	Part O: Front Bottom
2	Part D: Front Stiffener	1	Part P: Spool Top
2	Part E: Top Stiffener	1	Part Q: Machine Side
1	Part F: Rear Middle	1	Part R: Rear Right Stiffener
1	Part G: Rear Shelf	1	Part S: Spool Top Support
1	Part H: Rear Bottom	70	M3-10mm bolts
1	Part I: Rear Right	70	M3 square nuts
1	Part J: Rear Left	4	M4-8mm bolts
1	Part K: Front Left	4	M4 square nuts
1	Part L: Front Right	8	M5-20mm bolts

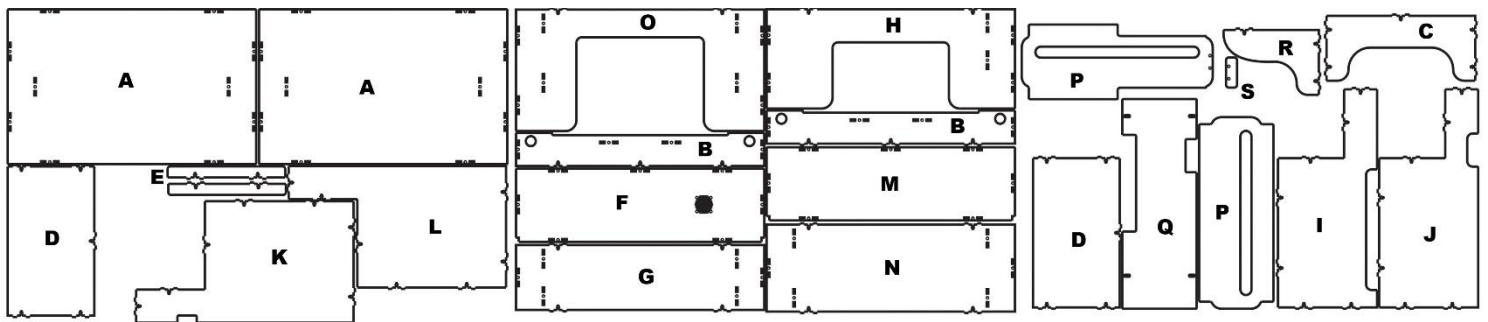

Tools Needed

- 3mm hex driver
- 4mm hex driver
- Optional: Painters tape
- Optional: Flat razor
- Optional: Zip Tie

Time Required

2-3 hours based on skill level

WARNINGS

Do not over tighten the screws in the hood. Tighten them just enough to hold without moving around.

You can crack the acrylic very easily by over tightening.

If you do crack a panel please contact printedsolid.com for replacements at a discounted rate.

The enclosure is made from extruded acrylic for optical clarity that helps reduce visual distortions. Do not use household cleaners to clean the Acrylic. Use dish soap or hand wash and do not scrub or use any abrasives.



Step 1:

Print out 2 left brackets, 1 right bracket and one left cable bracket located at <http://www.printedsolid.com/enclosures> for a total of 4 pieces. The left cable bracket allows for clearance of the extruder cable bundle. PLA filament with a layer height of at least .2 with 4 or more shells and at least 20% infill is recommended. Supports are needed for this print however they are minimal.

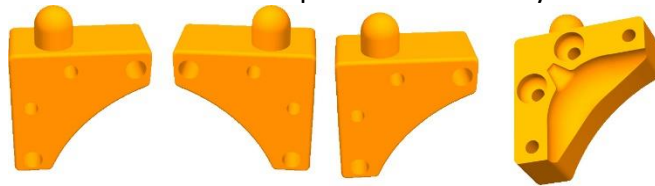

Step 2:

Install the brackets on the front and rear of the printer. Using a 3mm hex driver to remove the existing screws and install the brackets using the included M5-20mm bolts and a 4mm hex driver. While there is still support for the top of the printer with the screws removed it is recommended to do one bracket at a time. Note that the original nut in the extrusion will fall down once you remove the screw. Don't worry if this happens, you will need to move the screw back into place. A great way to prevent this is to fold over a zip tie and slide it into the slot to hold the nut in place.

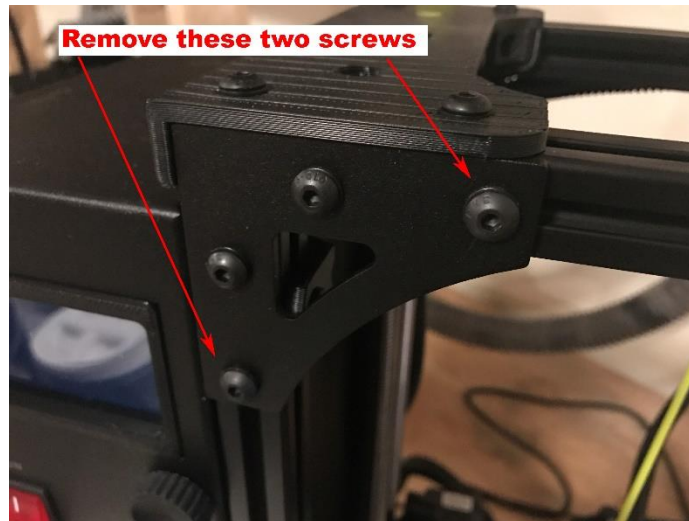

Step 3:

Note the letters on the individual acrylic pieces and then remove the protective covering from both sides of the pieces. While the front and back covers share similar pieces there are some differences. The sides, top and bottom are thicker for the front than for the back. This is to accommodate the build plate while keeping the enclosure total size at the tightest dimensions. It may be easier to remove the protective coverings as you do each part if you feel more comfortable working that way but it is important that the protective covering be removed before assembly of each part since they interlock into one another preventing you from removing it later. Use either your finger nail or a flat razor to pull up on the the edge of the protective covering. Take your time and pull slowly to get any additional stray pieces.

Step 4:

Warning!!! Remove the SD card from the printer before continuing. Gently set the printer on its side with the control box flat on the work surface. It is a good idea to lay down a towel or something soft to prevent scratching the side of the printer. Install Part Q on the side using the 4 M4-8mm bolts and M4 square nuts. Slide 2 square nuts in from the bottom of the machine into the extrusion on each side. Tighten down the bolts just enough to prevent slippage. The cut outs on the sides allow for the arm and filament guide to completely fold up or down.

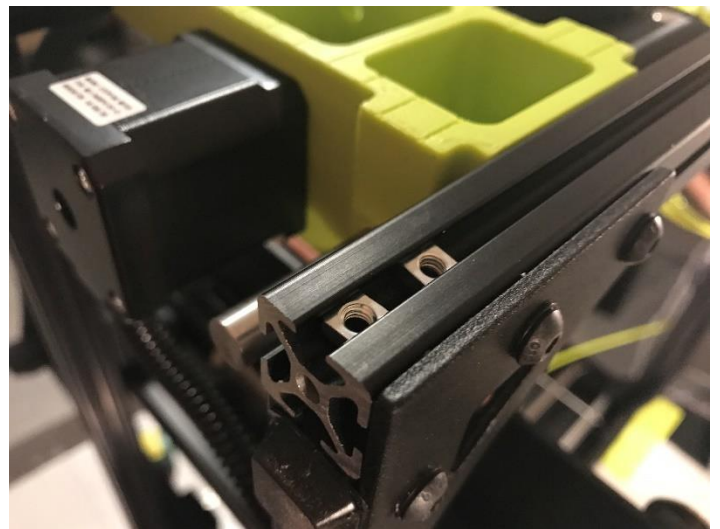

Step 5:

We have included two different versions of part P. One version has 2 screw holes and is joined with Part S using 2 M3-10 bolts and 2 M3 square nuts. This version is for users who prefer to use a top mounted spool option. The other version is for those who prefer the side spool mounted option. Either option sits onto of the machine and can be lifted off for easy access.

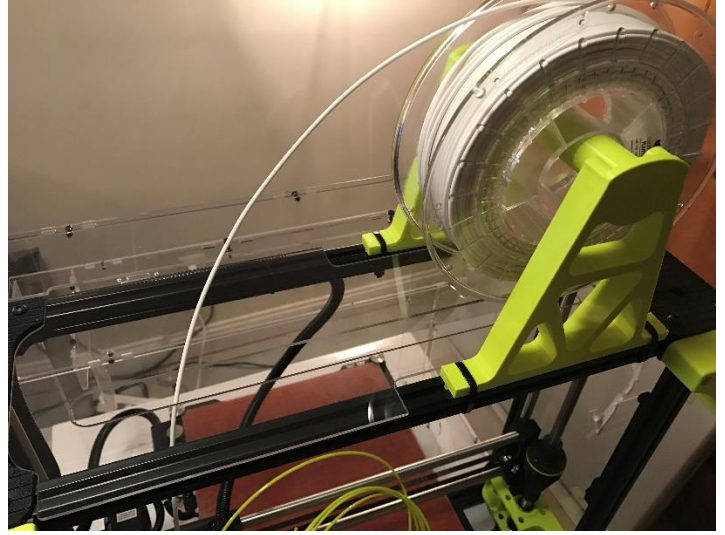
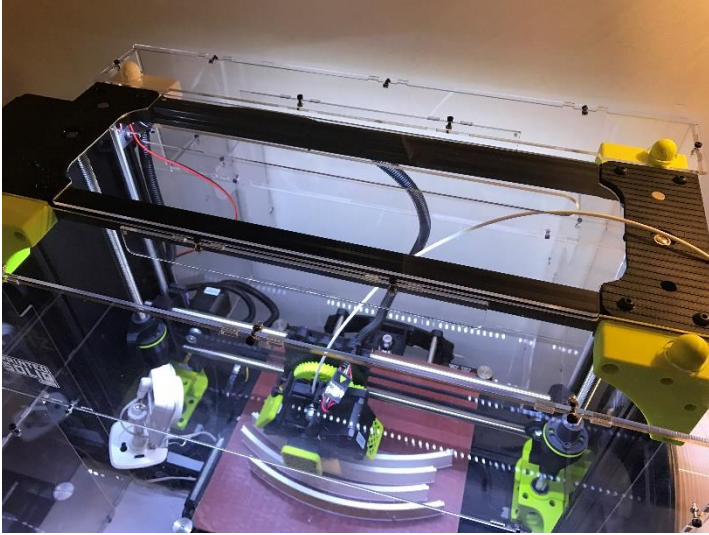

Part P option for side mounted spool

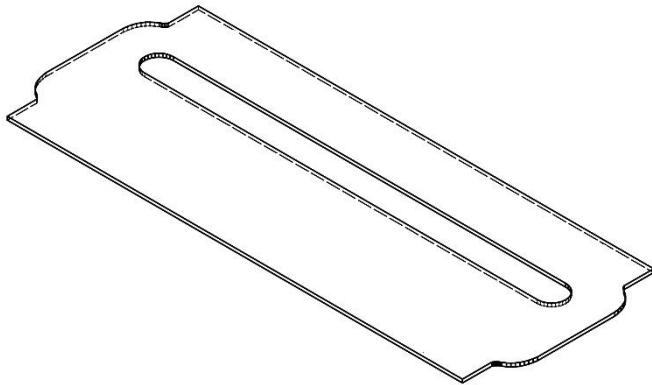

Part P option for top mounted spool

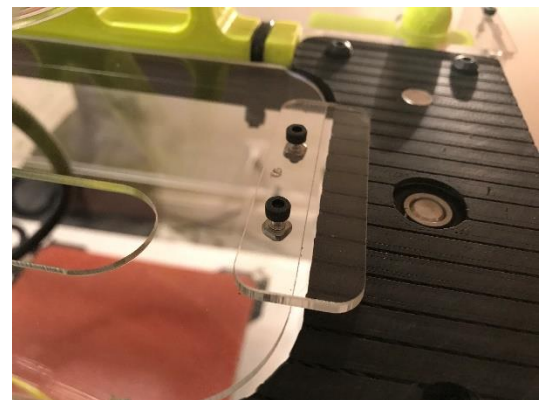
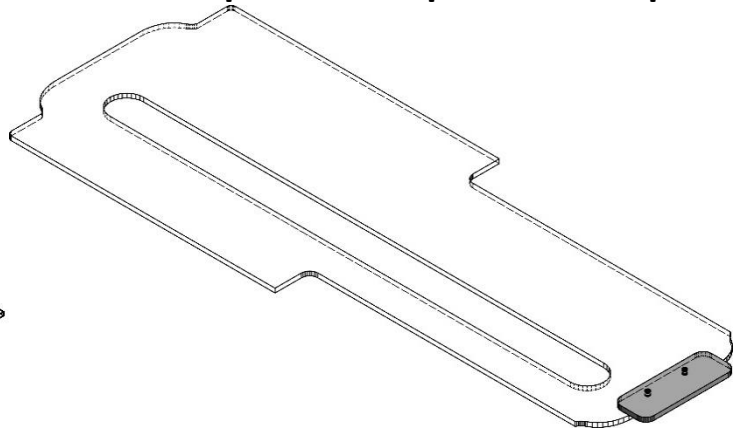

Step 6:

Attach the front bottom (Part O) to the front panel (Part A). The square nut sits in the slot and the 2 M3-10mm bolt goes through the front panel into the square nut. If you find it difficult to keep the nut in place while you insert the bolt you can use some painters tape to hold the nut in place for assembly. **DO NOT OVER TIGHTEN THE BOLTS.** Tighten them by hand and slightly more than 1/8th of a turn with a hex driver is enough to hold everything together.

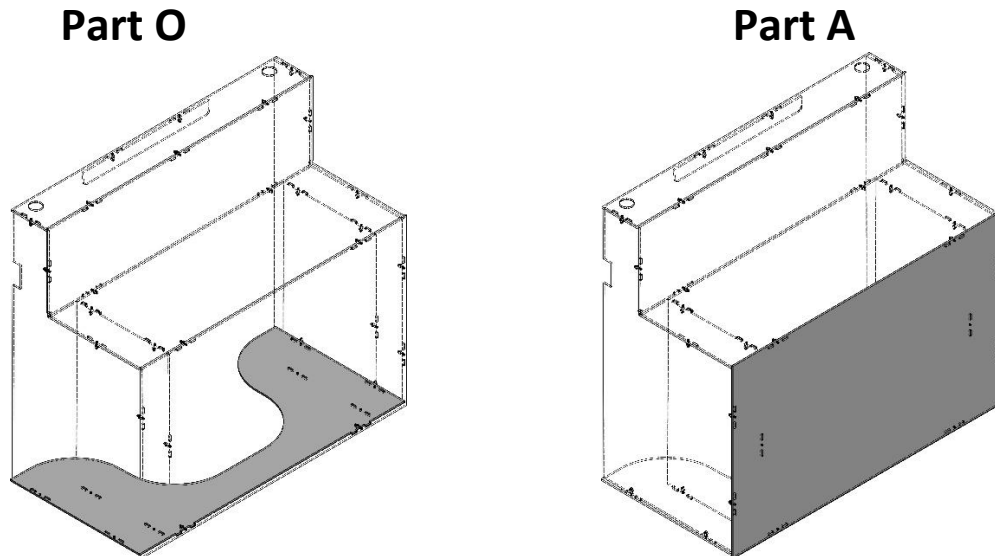

Step 7:

Attach the front left (Part K) to the front panel (Part A) and front bottom (Part O). Then attach the front right (Part L) in the same manor. The square nuts sits in the slot and the M3-10mm bolts goes through the hole and into the square nut. If you find it difficult to keep the nut in place while you insert the bolt you can use some painters tape to hold the nut in place for assembly. **DO NOT OVER TIGHTEN THE BOLTS.** Tighten them by hand and slightly more than 1/8th of a turn with a hex driver is enough to hold everything together.

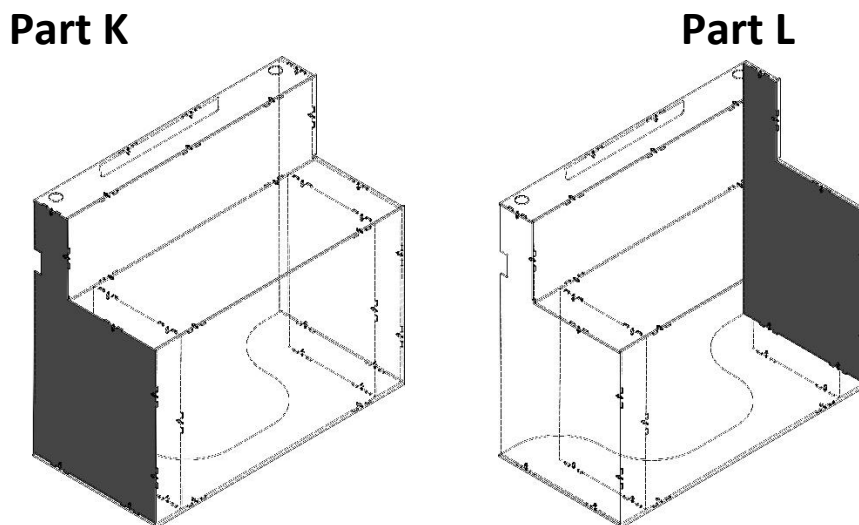

Step 8:

Attach the 2 front stiffeners (Part D) to the front panel (Part A) and front bottom (Part O). The square nuts sits in the slot and the M3-10mm bolts goes through the hole and into the square nut. If you find it difficult to keep the nut in place while you insert the bolt you can use some painters tape to hold the nut in place for assembly. **DO NOT OVER TIGHTEN THE BOLTS.** Tighten them by hand and slightly more than 1/8th of a turn with a hex driver is enough to hold everything together.

Part D

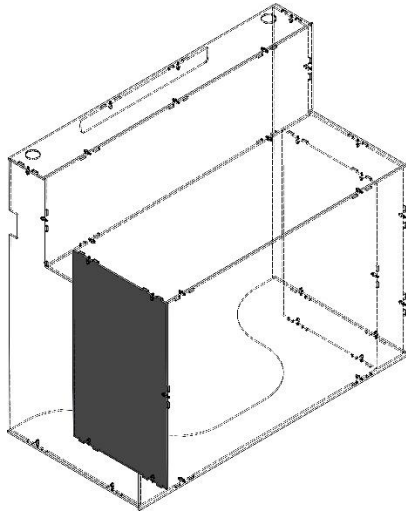

Part D

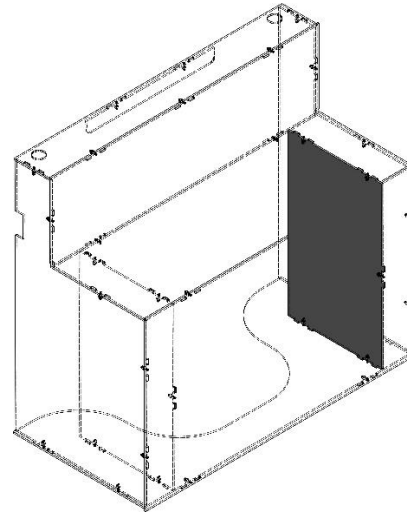

Step 9:

Attach the front shelf (Part N) to the front panel (Part A) and front sides (Part K&L). Then attach the front middle (Part M) to the front sides (Part K&L) and front shelf (Part N). Note how the front middle (Part M) tucks in behind the front shelf (Part N). Then bolt the 2 front stiffeners (Part D). The square nuts sits in the slot and the M3-10mm bolts goes through the hole and into the square nut. If you find it difficult to keep the nut in place while you insert the bolt you can use some painters tape to hold the nut in place for assembly. **DO NOT OVER TIGHTEN THE BOLTS.** Tighten them by hand and slightly more than 1/8th of a turn with a hex driver is enough to hold everything together.

Part N

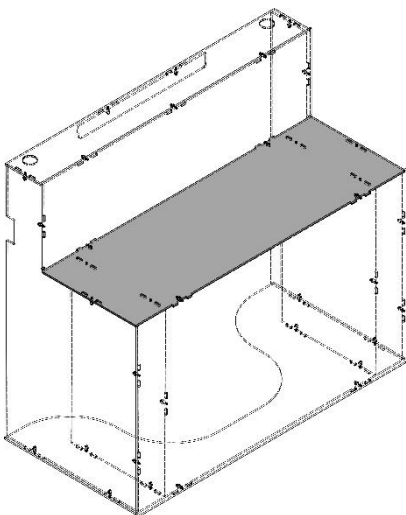

Part M

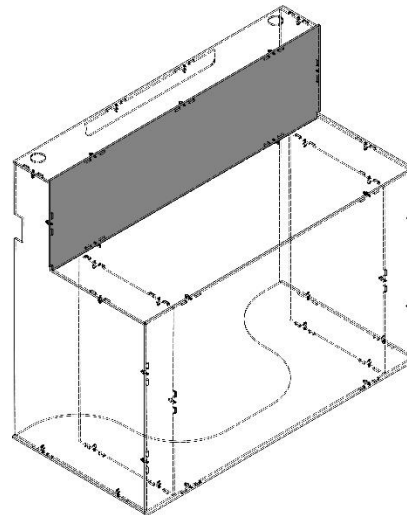

Step 10:

Attach the top mount with holes (Part B) to the front middle (Part M) and front sides (Part K&L). Then attach the top stiffener (Part E) The square nuts sits in the slot and the M3-10mm bolts goes through the hole and into the square nut. If you find it difficult to keep the nut in place while you insert the bolt you can use some painters tape to hold the nut in place for assembly. **DO NOT OVER TIGHTEN THE BOLTS.** Tighten them by hand and slightly more than $1/8^{\text{th}}$ of a turn with a hex driver is enough to hold everything together.

Part B

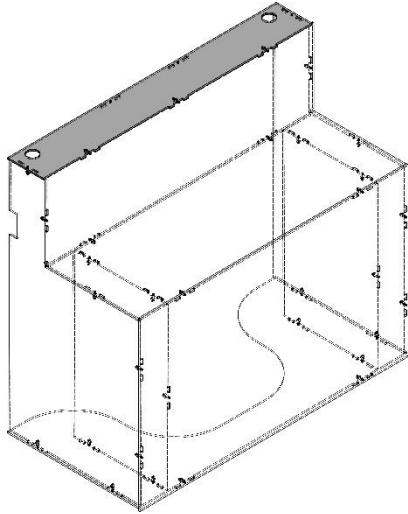

Part E

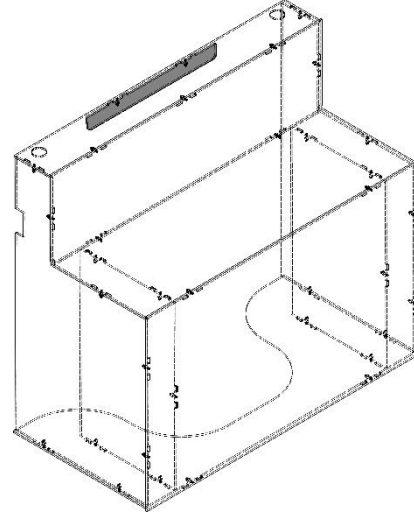

Step 11:

Attach the rear bottom (Part H) to the rear panel (Part A). Note on the rear bottom the set of holes on the inside on just the left side of the picture for orientation. This is needed for the next step. The square nut sits in the slot and the 2 M3-10mm bolt goes through the rear panel into the square nut. If you find it difficult to keep the nut in place while you insert the bolt you can use some painters tape to hold the nut in place for assembly. **DO NOT OVER TIGHTEN THE BOLTS.** Tighten them by hand and slightly more than $1/8^{\text{th}}$ of a turn with a hex driver is enough to hold everything together.

Part H

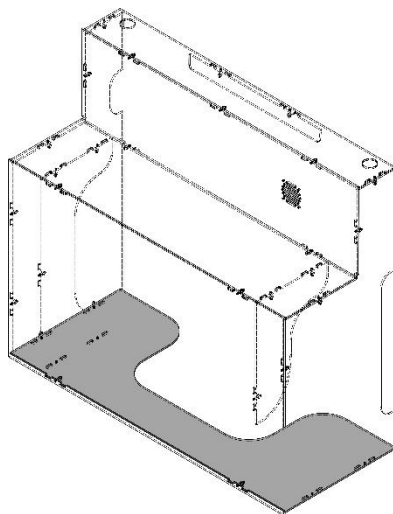

Part A

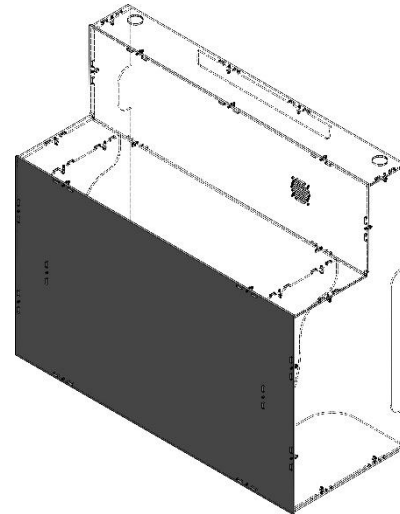

Step 12:

Attach the rear left (Part J) to the rear panel (Part A) and rear bottom (Part H). Then attach the rear right (Part I) in the same manor. The square nuts sits in the slot and the M3-10mm bolts goes through the hole and into the square nut. If you find it difficult to keep the nut in place while you insert the bolt you can use some painters tape to hold the nut in place for assembly. **DO NOT OVER TIGHTEN THE BOLTS.** Tighten them by hand and slightly more than 1/8th of a turn with a hex driver is enough to hold everything together.

Part J

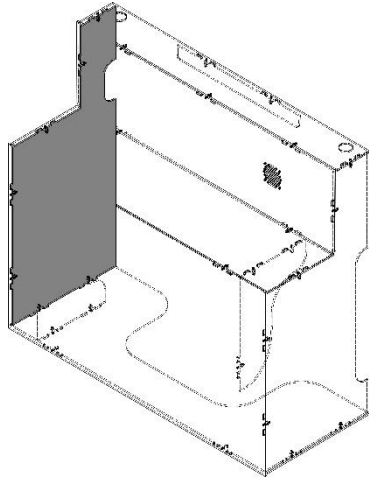

Part I

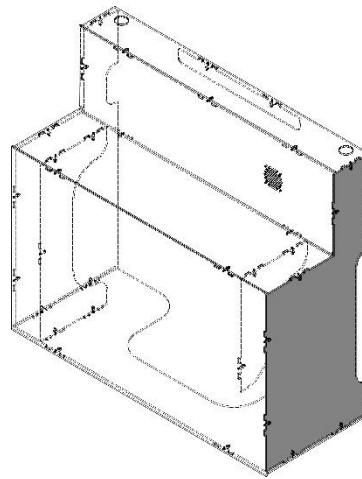

Step 13:

Attach the rear left stiffener (Part C) to the rear panel (Part A) and rear bottom (Part H). Then attach the rear right stiffener (Part R) to the rear panel (Part A). The square nuts sits in the slot and the M3-10mm bolts goes through the hole and into the square nut. If you find it difficult to keep the nut in place while you insert the bolt you can use some painters tape to hold the nut in place for assembly. **DO NOT OVER TIGHTEN THE BOLTS.** Tighten them by hand and slightly more than 1/8th of a turn with a hex driver is enough to hold everything together.

Part C

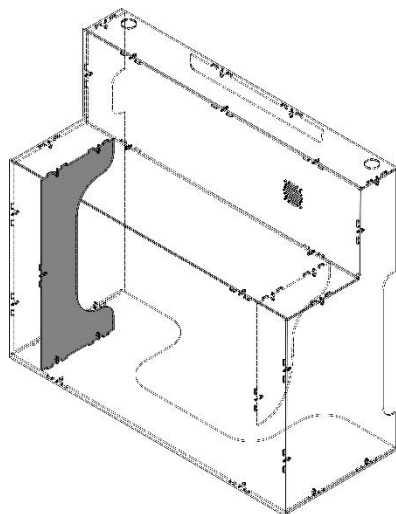

Part D

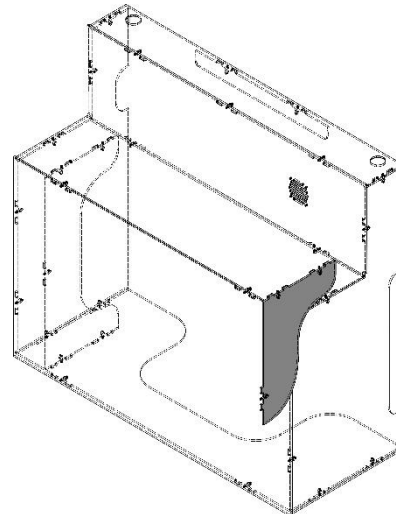

Step 14:

Attach the rear shelf (Part G) to the rear panel (Part A) and rear sides (Part I&J). Then attach the rear middle (Part F) to the rear sides (Part I&J) and rear shelf (Part G). Note how the rear middle (Part F) tucks in behind the rear shelf (Part G). Then bolt the rear left stiffener (Part C) and rear right stiffener (Part R). The vent on Part F is reversible depending on what side you would like it on. The square nuts sits in the slot and the M3-10mm bolts goes through the hole and into the square nut. If you find it difficult to keep the nut in place while you insert the bolt you can use some painters tape to hold the nut in place for assembly. **DO NOT OVER TIGHTEN THE BOLTS.** Tighten them by hand and slightly more than 1/8th of a turn with a hex driver is enough to hold everything together.

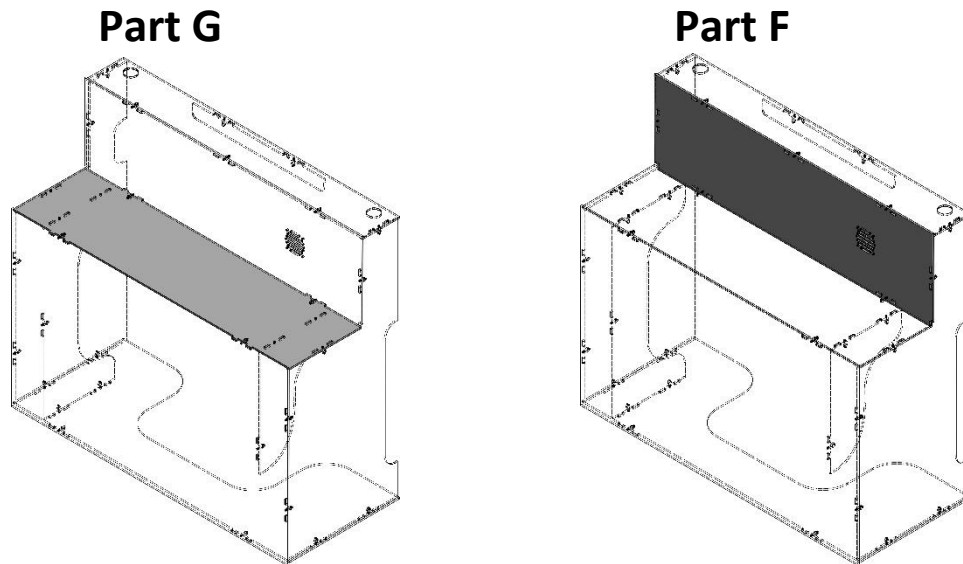

Step 15:

Attach the top mount with holes (Part B) to the rear middle (Part F) and rear sides (Part I&J). Then attach the top stiffener (Part E). The square nuts sits in the slot and the M3-10mm bolts goes through the hole and into the square nut. If you find it difficult to keep the nut in place while you insert the bolt you can use some painters tape to hold the nut in place for assembly. **DO NOT OVER TIGHTEN THE BOLTS.** Tighten them by hand and slightly more than 1/8th of a turn with a hex driver is enough to hold everything together.

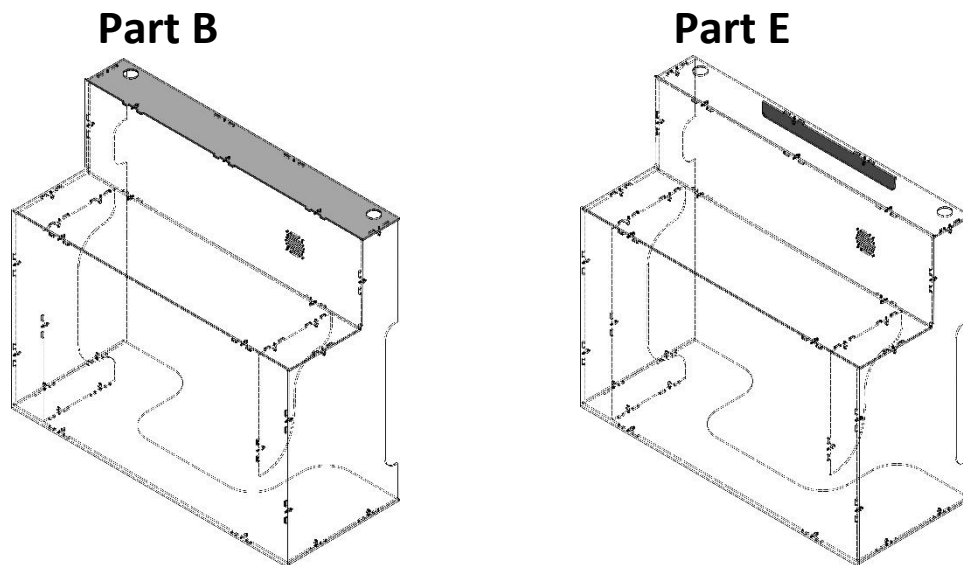

Proper Usage:

You can lift the front or back up and off the 3D printed post. The cutout on the bottom helps to clear the arms on the bed of the printer. It is normal for the cover to sit on the table and is part of the design to help reduce the risk of accidental breakage of the top plates. You will also notice the post holes are slightly enlarged and the front/back covers are slightly larger than the top and side covers. This is intentional to help prevent accidental snags or breakage after repeated use.

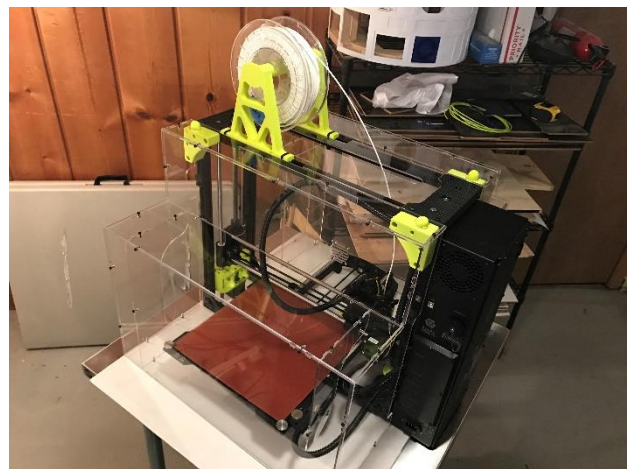
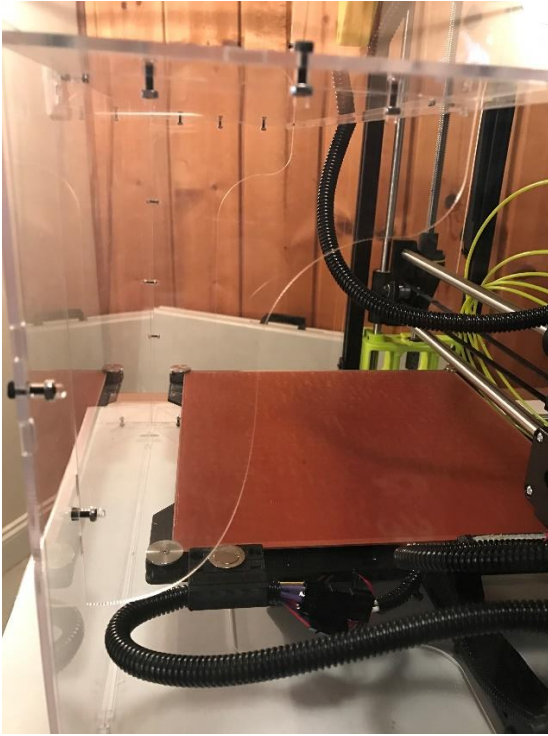



Congratulations on a job well done!

