

OSRAM SFH 7771

Datasheet

Discontinued

Published by ams-OSRAM AG

Tobelbader Strasse 30, 8141 Premstaetten, Austria

Phone +43 3136 500-0

ams-osram.com

© All rights reserved



Chip on board

SFH 7771

Ambient Light and Proximity Sensor



Applications

- 3D Sensing

Features

- ESD: 2 kV acc. to ANSI/ESDA/JEDEC JS-001 (HBM, Class 2)
- Miniature package
- I²C interface (max. 400kHz)

Ordering Information

Type
SFH 7771

Ordering Code
Q65111A4189

Application diagram 1

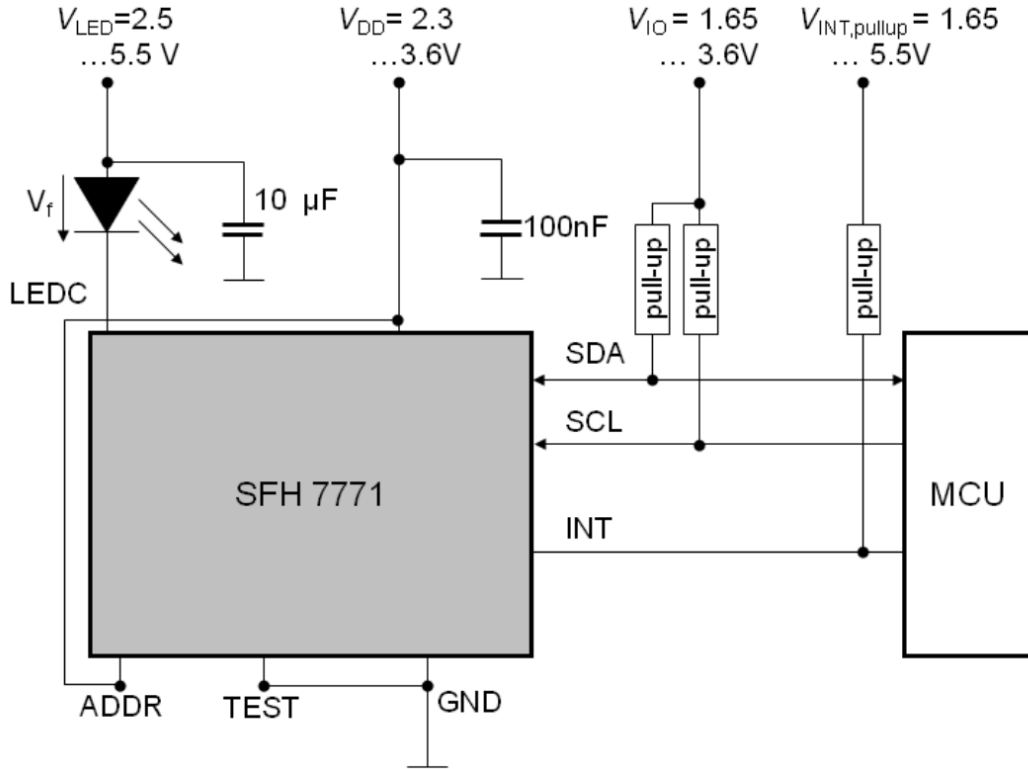

- Cathode of the emitter is directly connected to the sensor ($I_f \text{ max} = 200 \text{ mA}$)
- Bypass capacitors for V_{DD} and V_{LED} are required for proper operation of the device.
- This example shows ADDR-Pin connected to VDD. Therefore, the I²C-Address is 0111001 binary.
- Proposed size for the pull-up resistors are 10kOhm.

Application diagram 2

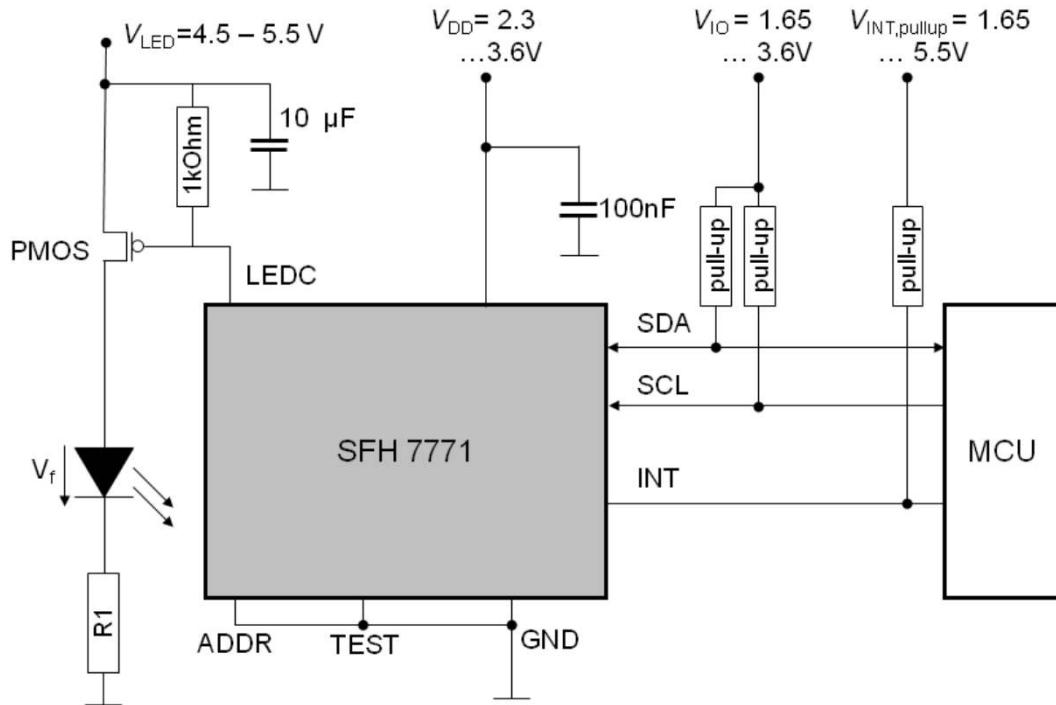

- Emitter is driven externally over a PMOS transistor
- Bypass capacitors for VDD and VLED are required for proper operation of the device.
- This example shows ADDR-Pin connected to VDD. Therefore the I2C-Address is 0111000 binary.
- Proposed size for the pull-up resistors are 10kOhm.

Pin configuration

Pin	Name	Function
1	ADDR	I2C address pin; connect to GND for 0x38 (7 bit-address) V _{DD} for 0x39 (7 bit-address)
2	V _{DD}	Power supply pin
3	GND	Ground pin
4	TEST	Test pin; connected to GND
5	SCL	I2C bus serial clock pin
6	SDA	I2C bus serial data pin
7	INT	Interrupt pin; open drain output; configured via I2C bus
8	LEDC	LED cathode pin; current and interval is defined via I2C bus

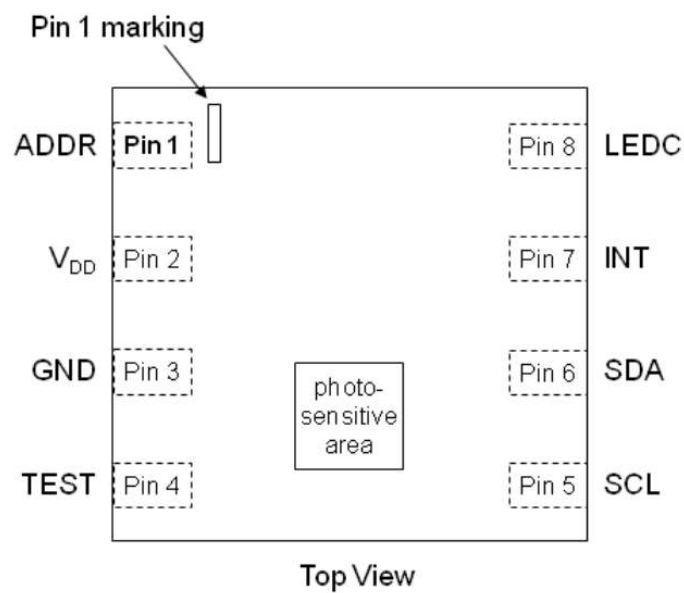

Short Evaluation program

Register	Command	Action
0x42	0x3F	set LED pulse current to 200mA and ALS gain to 0128
0x41	0x06	activate ALS & PS with a measurement repetition time of 100ms
Wait 100ms		
0x44	read data	read LSB of proximity measurement data
0x45	read data	read MSB of proximity measurement data
0x46	read data	read LSB of ambient light measurement of VIS diode
0x47	read data	read MSB of ambient light measurement of VIS diode
0x48	read data	read LSB of ambient light measurement of IR diode
0x49	read data	read MSB of ambient light measurement of IR diode

I²C Interface

- I/O-pins are open drain type and logic high level is set with external pull-up resistors
- SFH 7771 operates in slave mode. Slave address is 0111000 (0x38) when ADDR-Pin is connected to GND or 0111001 (0x39) if ADDR-Pin is connected to V_{DD}
- Designed for the I2C Fast mode (400 kb/s)
- Interrupt pin (INT): open-drain output (like SDA and SCL)

Block diagram

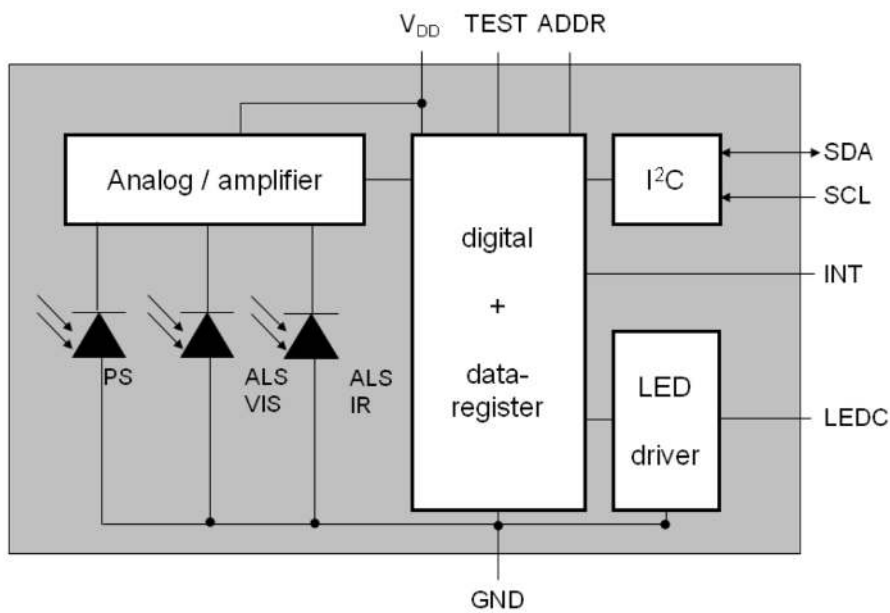

Discontinued

Characteristics

$T_A = 25\text{ °C}$

Parameter	Symbol		Values
Red Emitter			
Peak wavelength $I_F = 20\text{ mA}; t_p = 20\text{ ms}$	λ_{peak}	typ.	660 nm
Centroid Wavelength ⁶⁾ $I_F = 20\text{ mA}; t_p = 20\text{ ms}$	$\lambda_{\text{centroid}}$	min.	652 nm
		typ.	655 nm
		max.	658 nm
Spectral bandwidth at 50% Irel,max (FWHM) $I_F = 20\text{ mA}; t_p = 20\text{ ms}$	$\Delta\lambda$	typ.	17 nm
Half angle	φ	typ.	$\pm 60\text{ °}$
Rise time (10%/ 90%) $I_F = 100\text{ mA}; R_L = 50\ \Omega$	t_r	typ.	24 ns
Fall time (10%/ 90%) $I_F = 100\text{ mA}; R_L = 50\ \Omega$	t_f	typ.	24 ns
Forward voltage ⁷⁾ $I_F = 20\text{ mA}; t_p = 20\text{ ms}$	V_F	min.	1.7 V
		typ.	1.9 V
		max.	2.2 V
Reverse current $V_R = 12\text{ V}$	I_R		not designed for reverse operation
Radiant intensity ⁸⁾ $I_F = 20\text{ mA}; t_p = 20\text{ ms}$	I_e	min.	3.6 mW / sr
		typ.	4.6 mW / sr
		max.	6.9 mW / sr
Total radiant flux $I_F = 20\text{ mA}; t_p = 20\text{ ms}$	Φ_e	typ.	13.5 mW
Temperature coefficient of brightness $I_F = 20\text{ mA}; t_p = 20\text{ ms}$	TC_I	typ.	-0.7 % / K
Temperature coefficient of wavelength $I_F = 20\text{ mA}; t_p = 20\text{ ms}$	TC_λ	typ.	0.18 nm / K
Temperature coefficient of voltage $I_F = 20\text{ mA}; t_p = 20\text{ ms}$	TC_V	typ.	-1.7 mV / K
Thermal resistance junction solder point real	R_{thJS}	max.	265 K / W

Measurement modes

Mode	Description
OFF	The device is inactive. Other units may use the I2C bus without any restrictions; I/O pins and INT are in high Z state. There is no sink current through the LED
STAND-BY	This is the initial mode after power-up. IDD is typ. 0.8µA. No measurement is performed. Device can be activated by I2C bus communication. Data registers can be read and written.
ALS / PS free running	Measurements are triggered internally by the SFH 7771. Stand-by / active mode for ALS and PS measurement time, interrupt options and LED current can be adjusted via I2C register. Measurement results can be read from the data register, the status from the interrupt register

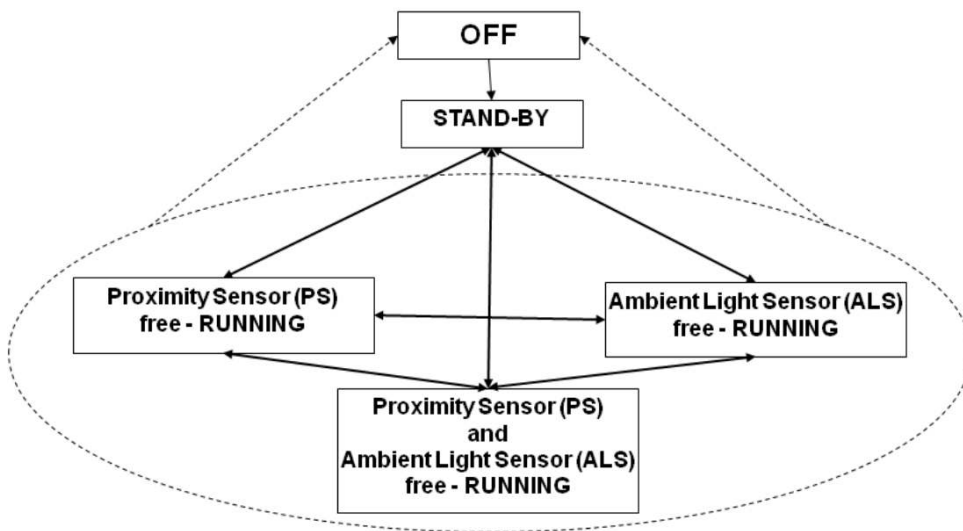

If VDD exceeds the threshold voltage, the sensor will switch from OFF mode to STAND-BY mode. As shown in the transition-diagram above it is possible to switch between all modes without any restriction.

Maximum Ratings

$T_A = 25\text{ °C}$

Parameter	Symbol		Values
Operating temperature range	T_{op}	min.	-40 °C
		max.	85 °C
Storage temperature range	T_{stg}	min.	-40 °C
		max.	100 °C
Maximum supply voltage between V_{DD} and GND	V_{DD}	max.	4.5 V
Maximum voltage of SDA, SCL to GND	V_{SDA}/V_{SCL}	max.	4.5 V
Maximum voltage of INT to GND	V_{INT}	max.	7 V
Maximum voltage of VLED to GND	V_{LEDC}	max.	7 V
Maximum Current of INT and SDA	I_{INT} / I_{SDA}	max.	7 mA
ESD withstand voltage acc. to ANSI/ESDA/JEDEC JS-001 (HBM, Class 2)	ESD	max.	2 kV

Operating conditions

Parameter	Symbol		Values
Supply voltage	V_{DD}	min.	2.3 V
		typ.	2.5 V
		max.	3.6 V
Ripple on supply voltage	$V_{DD,rip}$	max.	200 mV
V_{DDmin} and V_{DDmax} must stay in the V_{DD} range, DC ... 100 MHz			
V_{DD} threshold voltage voltage to initiate the start-up procedure	$V_{DD,th}$	typ.	1.7 V
		max.	2.3 V
Pull-up Voltage for INT	$V_{INT,pullup}$	max.	5.5 V
Pull-up Voltage for SCL and SDA	V_{IO}	min.	1.65 V
		max:	3.6 V
SDA and SCL input low level voltage	$V_{SDA,low}$	max.	0.54 V
	$V_{SCL,low}$		
SDA and SCL input high level voltage	$V_{SDA,high}$	min.	1.26 V
	$V_{SCL,high}$		
SDA and SCL input current	$ISDA_{low}$	min.	-10 μ A
	$ISCL_{low}$	max.	10 μ A
INT output low level voltage ($I_{INT} = 3$ mA)	$V_{INT,low}$	max.	0.4 V
When INT is active $V_{INT} = low$.			
When INT is inactive $V_{INT} = high$			
LEDC Terminal Voltage	V_{LED}	min.	0.7 V
		typ.	2.5 V
		max.	5.5 V
Ripple V_{LED}	$V_{LED,rip}$	max.	200mV

Characteristics

T_A = 25 °C

Parameter	Symbol		Values
Conditions for OFF mode	V _{DD,off}	typ.	0.5 V
Current consumption in OFF mode V _{DD} < 0.5 V	I _{DD,off}	typ.	0 µA
STAND-BY mode current consumption Mode_control(0x41) = 0x00; V _{DD} = 2.5 V	I _{DD,stby}	typ. max.	0.8 µA 1.5 µA
Proximity Sensor (PS)			
Wavelength of maximum sensitivity	λ _{S,max}	typ.	850 nm
Sensitivity range λ = 850nm	E _e	typ.	1 ... 5000 µW/cm ²
Proximity sensor output E _e = 324 µW/cm ² ; Ambient irradiance = 0 µW/cm ²	PS _{out}	min. typ. max.	187 counts 234 counts 281 counts
LED on time for one measurement	t _{LED ON}	min. typ. max.	80 µs 200 µs 300 µs
LED current, programmable	I _{LED}	min. max.	25 mA 200 mA
Accuracy of LED current source ALS_PS_CONTROL: LED Current (0b00)	I _{LED}	min. typ. max.	22.5 mA 25 mA 27.5 mA
Mean current consumption in PS mode current consumption of the pulsed LED is not included; MODE_CONTROL(0x41) = 0x03; all other registers are default; V _{DD} = 2.5 V	I _{DD}	typ. max.	90 µA 150 µA
Mean current consumption in PS mode during the 200 µs LED pulse (t _{LED ON}) current consumption of the pulsed LED is not included	I _{DD}	typ. max.	6.5 mA 8.5 mA
Temperature coefficient of proximity sensor	TC _{PS}	typ.	0.15 % / K

Example of Proximity Setup

When proximity sensing is performed, it is desirable that only light from a reflecting object reaches the SFH 7771. Depending on the optical setup, additional and unintended light paths from the IR-Emitter to the detector may exist, which is referred to as '(optical) crosstalk'. One measure to avoid such crosstalk is to add a separator between emitter and detector as drafted in the picture below. For details please refer to our SFH 7771 application note.

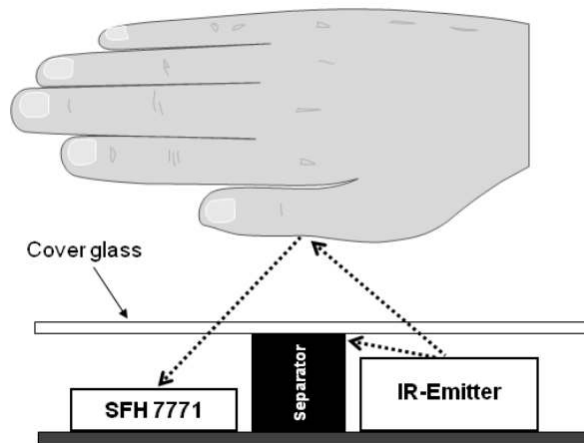

Characteristics

T_A = 25 °C

Parameter	Symbol		Values
Ambient Light Sensor: ALS_VIS and ALS_IR diode			
Wavelength of max. sensitivity for ALS_VIS	λ_{Smax}	typ.	520 nm
Spectral range of sensitivity (10 % of S _{max}) of ALS VIS	$\lambda_{S10\%}$	min.	380 nm
		max.	950 nm
Wavelength of max. sensitivity of ALS_IR	λ_{Smax}	typ.	880 nm
Spectral range of sensitivity (10 % of S _{max}) of ALS IR	$\lambda_{S10\%}$	min.	800 nm
		max.	1070 nm
Illuminance measurement range is programmable (MODE_CONTROL (0x41) = 0x0A or 0x0B)		min.	0.001 lx
		max.	43000 lx
ALS_VIS sensor output 1000lx; white LED; VDD = 2.5V MODE_CONTROL (0x41) = 0x08 ALS_PS_CONTROL (0x42): Gain X1	ALS _{VIS_out}	min.	1275 counts
		typ.	1500 counts
		max.	1725 counts
ALS_IR sensor output 324µW/cm ² ; IRED 850nm; VDD = 2.5V MODE_CONTROL (0x41) = 0x08 ALS_PS_CONTROL (0x42): Gain = X1	ALS _{IR_out}	min.	516 counts
		typ.	608 counts
		max.	700 counts
ALS_VIS sensor output at darkness MODE_CONTROL (0x41) 0x08 ALS_PS_CONTROL (0x42): Gain = X1	ALS _{VIS_out}	min.	0 counts
		typ.	0 counts
		max.	2 counts
ALS_IR sensor output at darkness MODE_CONTROL (0x41) = 0x08 ALS_PS_CONTROL (0x42): Gain = X1	ALS _{IR_out}	min.	0 counts
		typ.	0 counts
		max.	2 counts
Resolution of the digital output signal based on gain settings for ALS_VIS: MODE_CONTROL (0x41) = 0x08; t _{int ALS} = 100ms	ALS _{VIS_out}		
Gain X1		typ.	0.68 lx/count
Gain X2		typ.	0.34 lx/count
Gain X64		typ.	0.01 lx/count
Gain X128		typ.	0.005 lx/count
High sensitive mode: MODE_CONTROL (0x41) = 0x08; t _{int ALS} = 400ms			
Gain X128	typ.	0.001 lx/count	

Characteristics (continued)

T_A = 25 °C

Parameter	Symbol		Values
Ambient Light Sensor: ALS_VIS and ALS_IR diode			
Typical temperature coefficient for ALS measurement 1000lx; white LED; V _{DD} = 2.5V	TC _{EV}	typ.	0.2 % / K
Mean current consumption MODE_CONTROL (0x41) = 0x08 other registers are default	I _{DD}	typ. max.	90 µA 150 µA
Typical error by Flicker noise caused by bulbs (f=50 or 60 Hz) or fluorescent lamps		max.	3 %

Relative Spectral Sensitivity ^{1), 2)}

ALS_VIS

$$S_{rel_VIS} = f(\lambda)$$

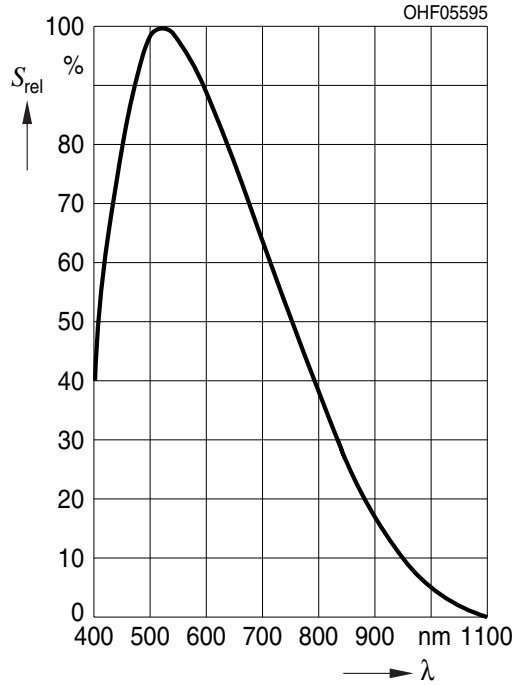

Relative Spectral Sensitivity ^{1), 2)}

ALS_IR

$$S_{rel_IR} = f(\lambda); 100\% = \text{maximum sensitivity of ALS_VIS diode}$$

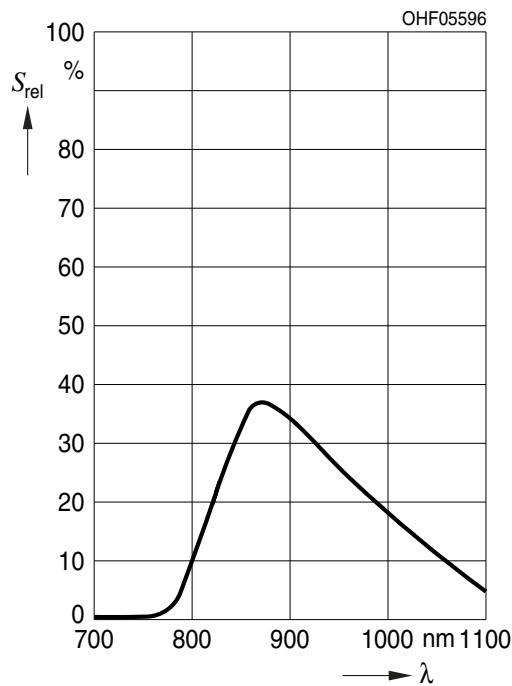

Discontinued

Directional Characteristics 1), 2)

ALS_VIS diode

$S_{rel} = f(\varphi)$

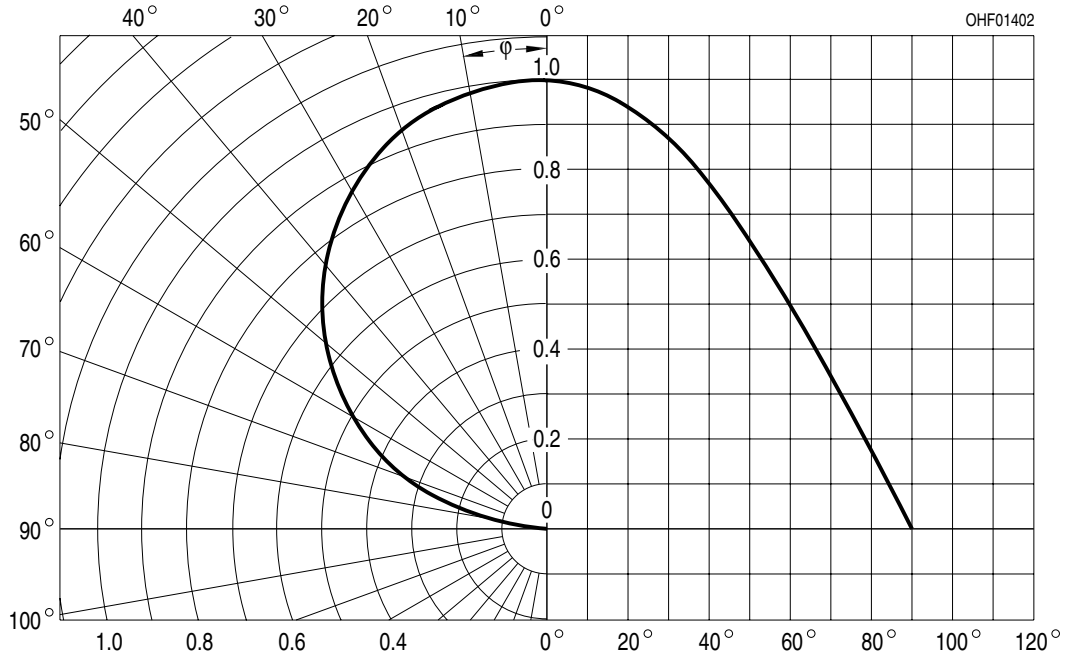

Current Consumption 1), 2)

standby mode

$I_{DD} = f(V_{DD}); \text{Register } 0x41 = 0x00$

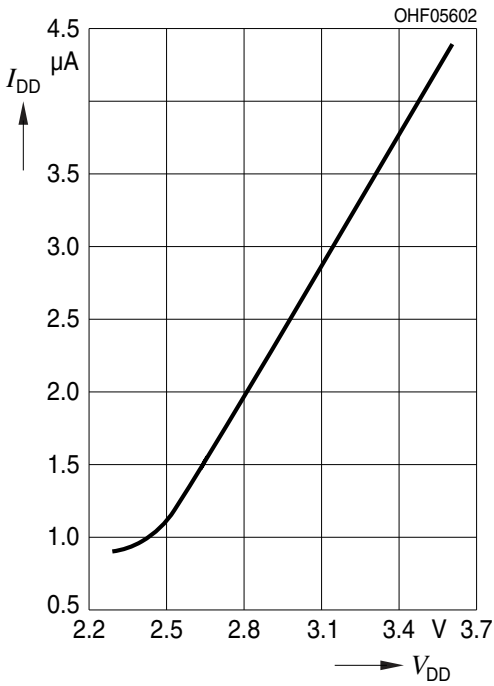

Current Consumption 1), 2)

PS mode

$I_{DD} = f(V_{DD}); \text{Register } 0x41=0x03$

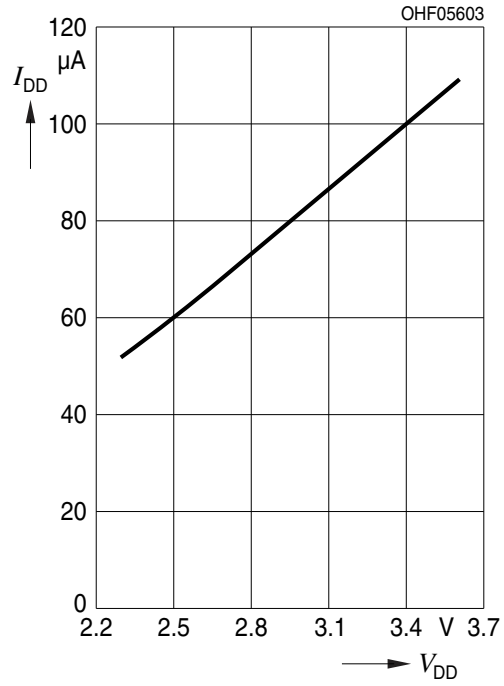

Discontinued

Current Consumption ^{1), 2)}

ALS mode

$I_{DD} = f(V_{DD})$; Register 0x41=0x08

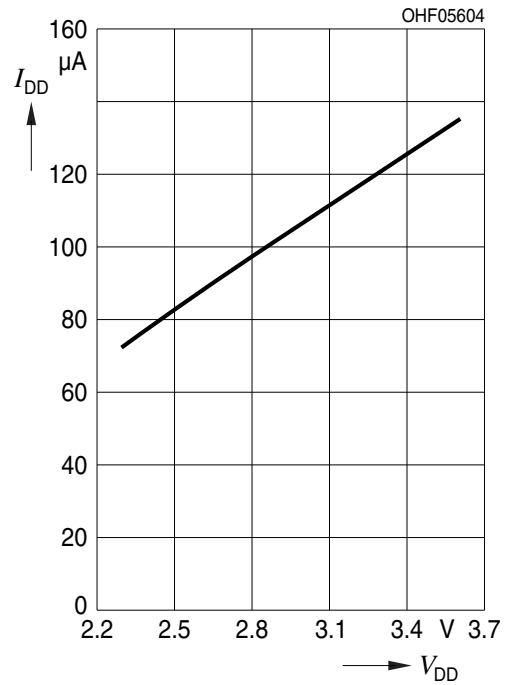

ALS_VIS sensitivity ranges

ALS_VIS output $f(E_v)$; white LED; $f(\text{sensitivity settings})$

T_{int} : integration time (register 0x41); X: gain settings (register 0x42)

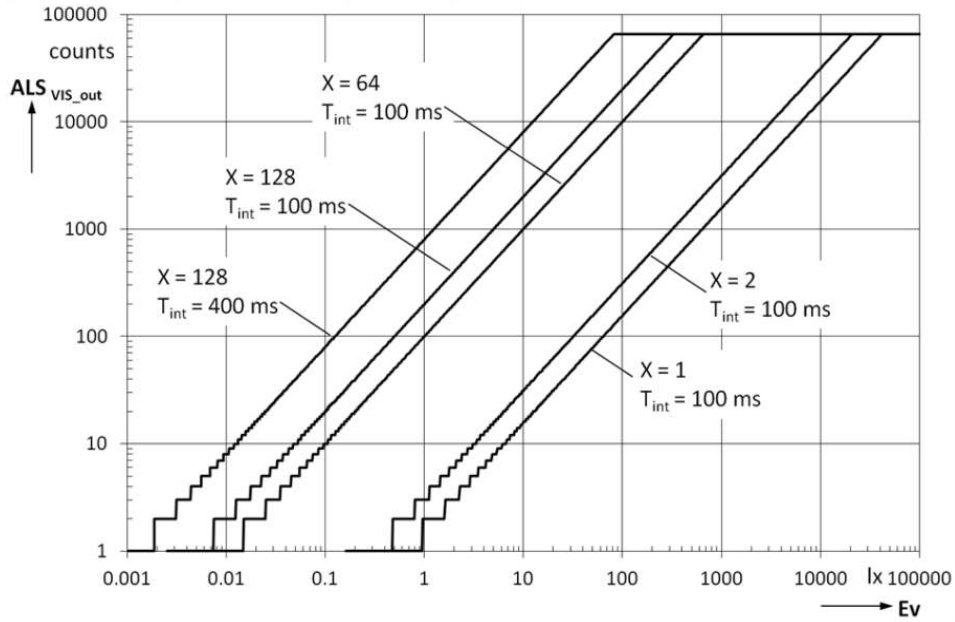

PS sensitivity $f(E_e = \text{irradiance})$

$V_{DD} = 2.5\text{V}; \lambda = 850\text{nm}$

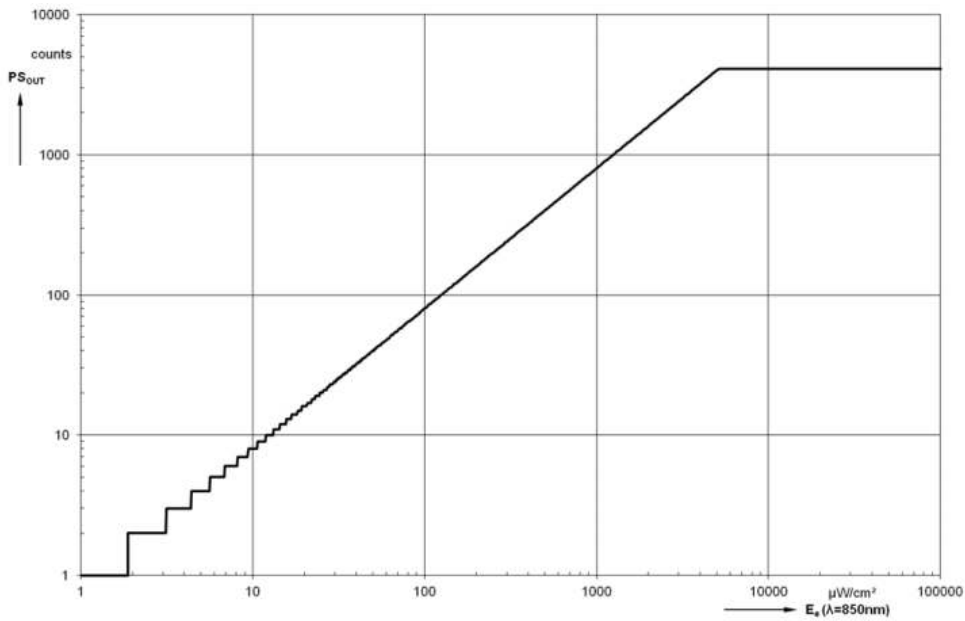

Registers Overview

Register	Type	Name	Function
0x40	R/W	SYSTEM_CONTROL	System Control
0x41	R/W	MODE_CONTROL	ALS and PS General Control
0x42	R/W	ALS_PS_CONTROL	ALS Gain and PS current Control
0x43	R/W	PERSISTENCE	PS Interrupt Persistence Control
0x44	R	PS_DATA_LSB	Output data of PS measurement, LSB
0x45	R	PS_DATA_MSB	Output data of PS measurement, MSB
0x46	R	ALS_VIS_DATA_LSB	Output data of ALS_VIS measurement, LSB
0x47	R	ALS_VIS_DATA_MSB	Output data of ALS_VIS measurement, MSB
0x48	R	ALS_IR_DATA_LSB	Output data of ALS_IR measurement, LSB
0x49	R	ALS_IR_DATA_MSB	Output data of ALS_IR measurement, MSB
0x4A	R/W	INTERRUPT_CONTROL	Interrupt Control
0x4B	R/W	PS_TH_LSB	PS interrupt upper threshold level, LSB
0x4C	R/W	PS_TH_MSB	PS interrupt upper threshold level, MSB
0x4D	R/W	PS_TL_LSB	PS interrupt lower threshold level, LSB
0x4E	R/W	PS_TL_MSB	PS interrupt lower threshold level, MSB
0x4F	R/W	ALS_VIS_TH_LSB	ALS_VIS interrupt upper threshold level, LSB
0x50	R/W	ALS_VIS_TH_MSB	ALS_VIS interrupt upper threshold level, MSB
0x51	R/W	ALS_VIS_TL_LSB	ALS_VIS interrupt lower threshold level, LSB
0x52	R/W	ALS_VIS_TL_MSB	ALS_VIS interrupt lower threshold level, MSB

SYSTEM_CONTROL register (0x40)

The SYSTEM_CONTROL register is used to control the software (SW) reset and the interrupt function (INT). Manufacturer ID and Part ID can be read.

R/W-Register 0x40

Bit	7	6	5	4	3	2	1	0
	SW reset	INT reset	Manufacturer ID (Read only)			Part ID (Read only)		
default	0 Initial reset is not started	0 INT pin status is not initialized	001			001		
	0 Initial reset is not started	0 INT pin status is not initialized						
	1 Initial reset started	1 INT pin become inactive (high impedance)						

MODE_CONTROL register (0x41)

CONTROL of PS and ALS operating modes and time settings.

Repetition time is the time between two separate measurements. Integration time is the duration for one measurement. ALS high sensitivity modes are 1010 and 1011 with an increased integration time of 400ms. In PS operating mode: “normal mode” only one PS measurement is performed during one PS repetition time. In PS operating mode: “twice mode” two independent PS measurement are performed within one PS repetition time. Both measurements are independent and can trigger the interrupt. This feature can be used to decrease the interrupt update time if the persistence function (register 0x43) is used.

R/W-Register 0x41

Bit	7	6	5	4	3	2	1	0	Repetition / Integration time	Repetition time
	Reserved			PS operating mode					ALS	PS
default				0 normal mode	0000				standby	standby
				0 normal mode	0000				standby	standby
				1 twice mode	0001				standby	10ms
					0010				standby	40ms
					0011				standby	100ms
					0100				standby	400ms
					0101				100ms / 100ms	standby
					0110				100ms / 100ms	100ms
					0111				100ms / 100ms	400ms
					1000				400ms / 100ms	standby
					1001				400ms / 100ms	100ms
					1010				400ms / 400ms	standby
					1011				400ms / 400ms	400ms
					1100				50ms / 50 ms	50ms
				Rest forbidden						

ALS_PS_CONTROL register (0x42)

ALS and PS Control of set the PS output mode, the ALS gain and the LED current. In the “Infrared DC level output” PS mode (bit <6> = 1) the sensor measures the infrared DC ambient level. The proximity value of the reflected signal is not available in this mode.

R/W-Register 0x42

Bit	7	6	5	4	3	2	1	0
	Reserved (read only)	PS output	ALS Gain for ALS_VIS and ALS_IR			LED current		
default	write 0	0 proximity output	0000	X1	X1	11 200mA		
		0 proximity output	0000	X1	X1	00 25 mA		
		1 Infrared DC level output	0100	X2	X1	01 50 mA		
			0101	X2	X2	10 100 mA		
			1010	X64	X64	11 200 mA		
			1110	X128	X64			
			1111	X128	X128			
			rest forbidden					

PERSISTENCE Register (0x43)

Setting of persistence interrupt function. Persistence function is only valid for the PS interrupt.

R/W-Register 0x43

Bit	7	6	5	4	3	2	1	0
	Reserved (read only)				Persistence			
default	0000				0001 Interrupt status is updated after each measurement			
					0000 Interrupt becomes active after each measurement (The mode indicates that a PS or ALS measurement has been finished and can be read via the register. It is independent of the ALS & PS measurement value and threshold settings)			
					0001 Interrupt status is updated after each measurement (The interrupt status is updated independently after each measurement. Active or Inactive status of the interrupt is depending on the values of the last measurement in combination with the interrupt settings: "interrupt mode" (register 0x4A) and "thresholds" register 0x4C and following.)			
					0010 Interrupt status is updated if two consecutive threshold judgement are the same (The interrupt status only changes if the interrupt judgement of 2 consecutive measurement results are the same and different to the current interrupt status.)			
					0011 ... 1111 Interrupt status is updated if threshold judgement are the same over consecutive set times (3 ... 15) (This is the same procedure like in the 0010 persistence mode, but instead of 2 consecutive threshold judgments more are needed (3 to 15 depending on the setting) to change the interrupt status.) e.g.: 1010: 10 measurement results in a row need to fulfill the interrupt judgement to update the interrupt status			

PS_DATA_LSBs Register (0x44)

LSB of the PS output.

R-Register 0x44

Bit	7	6	5	4	3	2	1	0
	2^7	2^6	2^5	2^4	2^3	2^2	2^1	2^0
default	0	0	0	0	0	0	0	0

PS_DATA_MSBs Register (0x45)

MSB of the PS output.

R-Register 0x45

Bit	7	6	5	4	3	2	1	0
	not used	not used	not used	not used	2^{11}	2^{10}	2^9	2^8
default	0	0	0	0	0	0	0	0

ALS_VIS_DATA_LSBs Register (0x46)

LSB of the ALS_VIS output.

R-Register 0x46

Bit	7	6	5	4	3	2	1	0
	2^7	2^6	2^5	2^4	2^3	2^2	2^1	2^0
default	0	0	0	0	0	0	0	0

ALS_VIS_DATA_MSBs Register (0x47)

MSB of the ALS_VIS output.

R-Register 0x47

Bit	7	6	5	4	3	2	1	0
	2^{15}	2^{14}	2^{13}	2^{12}	2^{11}	2^{10}	2^9	2^8
default	0	0	0	0	0	0	0	0

ALS_IR_DATA_LSBs Register (0x48)

LSB of the ALS_IR output.

R-Register 0x48

Bit	7	6	5	4	3	2	1	0
	2^7	2^6	2^5	2^4	2^3	2^2	2^1	2^0
default	0	0	0	0	0	0	0	0

ALS_IR_DATA_MSBs Register (0x49)

MSB of the ALS_IR output.

R-Register 0x49

Bit	7	6	5	4	3	2	1	0
	2^{15}	2^{14}	2^{13}	2^{12}	2^{11}	2^{10}	2^9	2^8
default	0	0	0	0	0	0	0	0

INTERRUPT_CONTROL register (0x4A)

Setting of the interrupt functions.

R/W-Register 0x4A

Bit	7	6	5	4	3	2	1	0
	PS INT status (read only)	ALS INT status (read only)	PS INT mode		INT assert	INT latch	INT trigger	
default	0 inactive	0 inactive	00 PS_TH is only active		0 INT "L" is stable	0 INT is latched	00 inactive	
	0 inactive	0 inactive	00 PS_TH (PS high threshold 0x4B & 0x4C) is only active		0 INT "L" is stable if newer measurement results is also interrupt active	0 INT is latched until INT registers is read or initialize	00 INT pin is inactive	
	1 active	1 active	01 PS_TH & PS_TL (PS high & low threshold) are active as hysteresis		1 INT "L" is de-assert and re-assert if newer measurement results is also interrupt active	1 INT is updated after each measurement	01 is triggered by PS only	
			10 PS_TH & PS_TL (PS high & low threshold) are active as outside detection				10 triggered by ALS only	
			11 forbidden				11 triggered by PS or ALS	

PS INT and ALS INT status (bit <7;6>): Directly after reading the register the interrupt status for PS and ALS and the INT Pin of the sensor is automatically set back to inactive status independent on the measurement results.

PS INT mode (bit <5;4>): The INT modes are only valid for the PS interrupt function. For description please see extra chapter "PS INT Modes" (at the end of the register chapter).

INT assert (bit <3>): Is used to adjust the sensor behavior to the used micro controller trigger settings. In case a repeated trigger in low state is needed the INT assert can be set to 1.

INT trigger (bit <2>): defines the source / sources for the interrupt.

INT latched (bit <1>): In latched mode the interrupt status stays active after the first activation. It is only released by reading the status are performing an interrupt reset.

PS_TH_LSBs register (0x4B)

LSB for the PS threshold “HIGH”.

R/W-Register 0x4B

Bit	7	6	5	4	3	2	1	0
	2^7	2^6	2^5	2^4	2^3	2^2	2^1	2^0
default	1	1	1	1	1	1	1	1

PS_TH_MSBs register (0x4C)

MSB for the PS threshold “HIGH”.

R/W-Register 0x4C

Bit	7	6	5	4	3	2	1	0
					2^{11}	2^{10}	2^9	2^8
default	0	0	0	0	1	1	1	1

PS_TL_LSBs register (0x4D)

LSB for the PS threshold “LOW”.

R/W-Register 0x4D

Bit	7	6	5	4	3	2	1	0
	2^7	2^6	2^5	2^4	2^3	2^2	2^1	2^0
default	0	0	0	0	0	0	0	0

PS_TL_MSBs register (0x4E)

MSB for the PS threshold “LOW”.

R/W-Register 0x4E

Bit	7	6	5	4	3	2	1	0
					2^{11}	2^{10}	2^9	2^8
default	0	0	0	0	0	0	0	0

ALS_VIS_TH_LSBs register (0x4F)

LSB for the ALS_VIS threshold "HIGH".

R/W-Register 0x4F

Bit	7	6	5	4	3	2	1	0
	2^7	2^6	2^5	2^4	2^3	2^2	2^1	2^0
default	1	1	1	1	1	1	1	1

ALS_VIS_TH_MSBs register (0x50)

MSB for the ALS_VIS threshold "HIGH".

R/W-Register 0x50

Bit	7	6	5	4	3	2	1	0
	2^{15}	2^{14}	2^{13}	2^{12}	2^{11}	2^{10}	2^9	2^8
default	1	1	1	1	1	1	1	1

ALS_VIS_TL_LSBs register (0x51)

LSB for the ALS_VIS threshold "LOW".

R/W-Register 0x51

Bit	7	6	5	4	3	2	1	0
	2^7	2^6	2^5	2^4	2^3	2^2	2^1	2^0
default	0	0	0	0	0	0	0	0

ALS_VIS_TL_MSBs register (0x52)

MSB for the ALS_VIS threshold "LOW".

R/W-Register 0x52

Bit	7	6	5	4	3	2	1	0
	2^{15}	2^{14}	2^{13}	2^{12}	2^{11}	2^{10}	2^9	2^8
default	0	0	0	0	0	0	0	0

INT modes

The Interrupt function compares ALS and PS measurement values with the current interrupt threshold level. PS and ALS_VIS Interrupt status is readable via register 0x4A or at the INT pin of the sensor.

The Interrupt persistence function is only valid for PS measurements and is defined in register (0x43). The INT pin of the SFH 7771 is open drain output and should be pulled up to $V_{INT,pullup}$ by an external resistor. When V_{DD} is supplied the INT pin is high impedance (inactive). The INT status becomes inactive by writing INT reset command, reading the INT status register or performing a software reset. The INT status stays in its last state when the sensor is set to the standby mode. In the INT active state "low" the sensor consumes $\sim 25\mu A$ extra current. Therefore OSRAM recommends to set the INT state to high impedance before setting the sensor in standby mode.

Following ALS and PS INT modes are described for the unlatched mode. In latched mode the switching back to the "inactive" INT state is depending on a interrupt reset or the read of the INT status register.

ALS INT mode:

The ALS_VIS threshold levels high (register 0x4F & 0x50) and low (register 0x4F & 0x50) are only valid for the ALS_VIS measurement values. The ALS_VIS INT mode is fixed and can not be adapted via register. The thresholds define a window with following functionality:

ALS INT is active, if the ALS_VIS measurement values are outside the window.

ALS INT is inactive, if the ALS_VIS measurement results are inside the window.

PS INT Modes: Bit <5;4> of INTERRUPT_CONTROL register (0x4A)

00 PS_TH is only active:

The INT state is active if the PS measurement result is equal or higher than the set PS_TH high threshold.

The INT state is inactive, if the PS measurement result is lower than the set PS_TH high threshold.

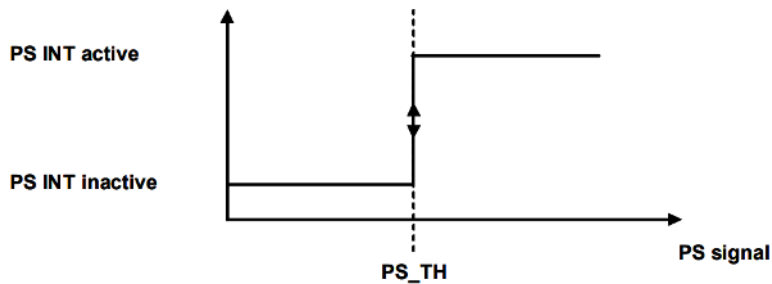

01 PS_TH & PS_TL (PS high & low threshold) are active as hysteresis:

PS_TH and PS_TL are working as a hysteresis. If the PS measurement signal is higher than the PS high threshold (PS_TH) the INT state is switched to active. If the PS measurement signal is lower than the PS low threshold (PS_TL) the INT state is inactive. If once interrupt signal becomes active, INT status is kept active until measurement result becomes less than PS_TL register value.

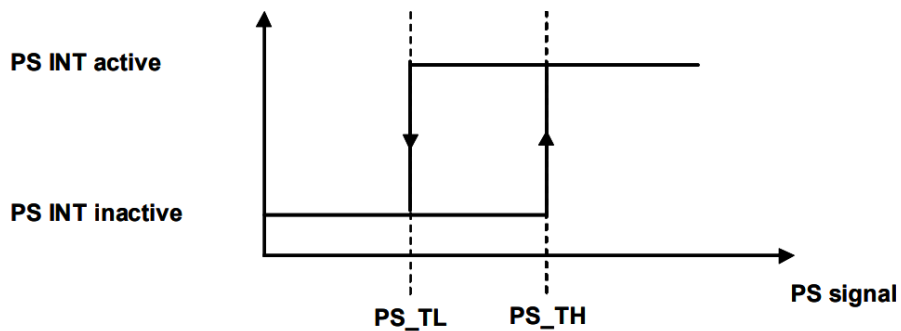

10 PS_TH & PS_TL (PS high & low threshold) are active as outside detection:

In case of "PS outside detection" mode interrupt signal inactive means that measurement result is within registered threshold level and interrupt signal active means measurement result is out of registered threshold level.

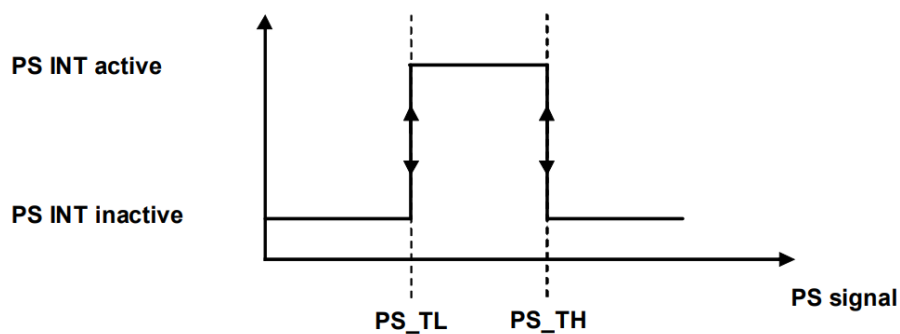

Dimensional Drawing ³⁾

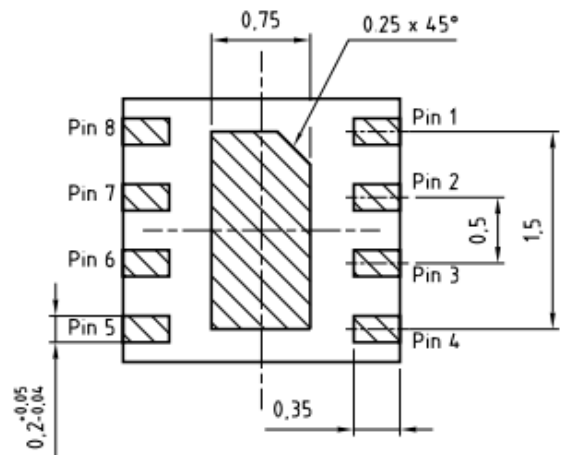
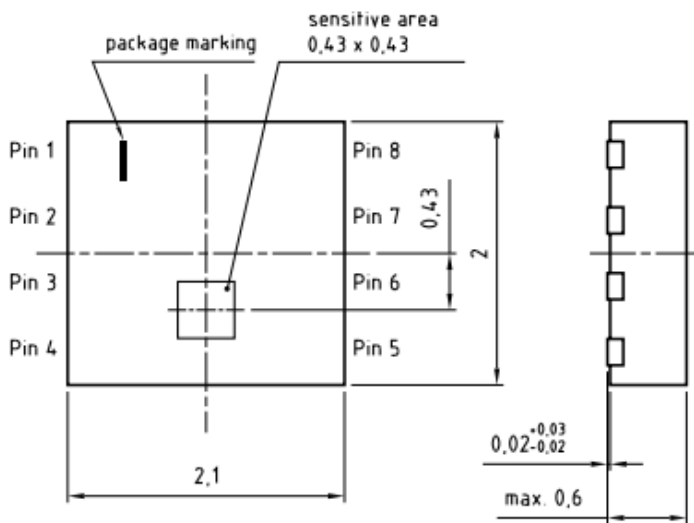

general tolerance $\pm 0,1$
lead finish Au

C63062-A4201-A1-03

Further Information:

Approximate Weight: 6.0 mg

Recommended Solder Pad ³⁾

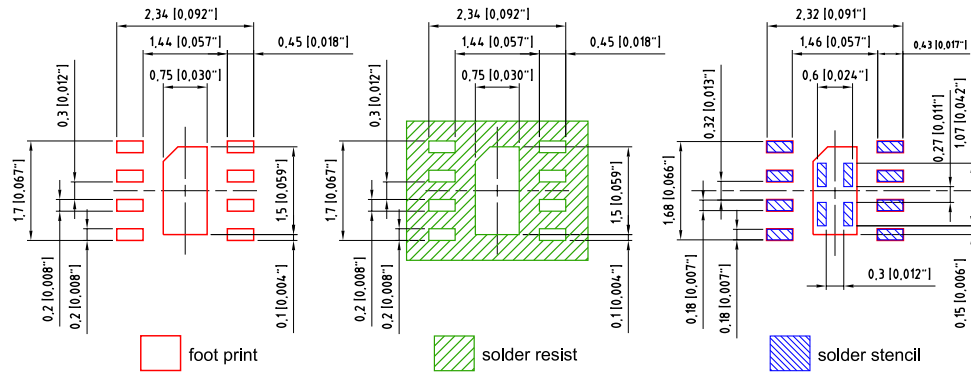

Component Location on Pad

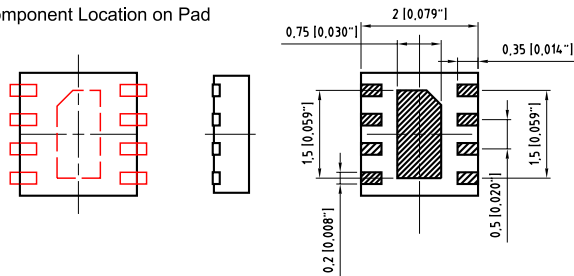

E062.3010.139 -01

Reflow Soldering Profile

Product complies to MSL Level 3 acc. to JEDEC J-STD-020E

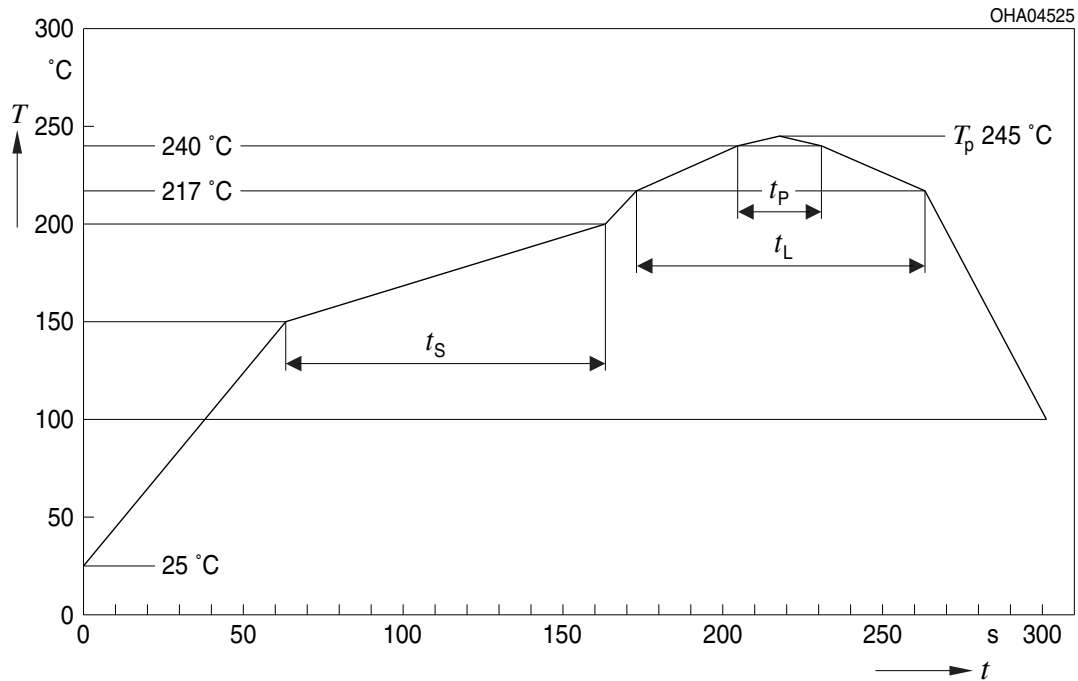

Profile Feature	Symbol	Pb-Free (SnAgCu) Assembly			Unit
		Minimum	Recommendation	Maximum	
Ramp-up rate to preheat ^{*)} 25 °C to 150 °C			2	3	K/s
Time t_s T_{Smin} to T_{Smax}	t_s	60	100	120	s
Ramp-up rate to peak ^{*)} T_{Smax} to T_p			2	3	K/s
Liquidus temperature	T_L		217		°C
Time above liquidus temperature	t_L		80	100	s
Peak temperature	T_p		245	260	°C
Time within 5 °C of the specified peak temperature $T_p - 5$ K	t_p	10	20	30	s
Ramp-down rate* T_p to 100 °C			3	6	K/s
Time 25 °C to T_p				480	s

All temperatures refer to the center of the package, measured on the top of the component
^{*)} slope calculation DT/Dt : Dt max. 5 s; fulfillment for the whole T-range

Discontinued

Taping ³⁾

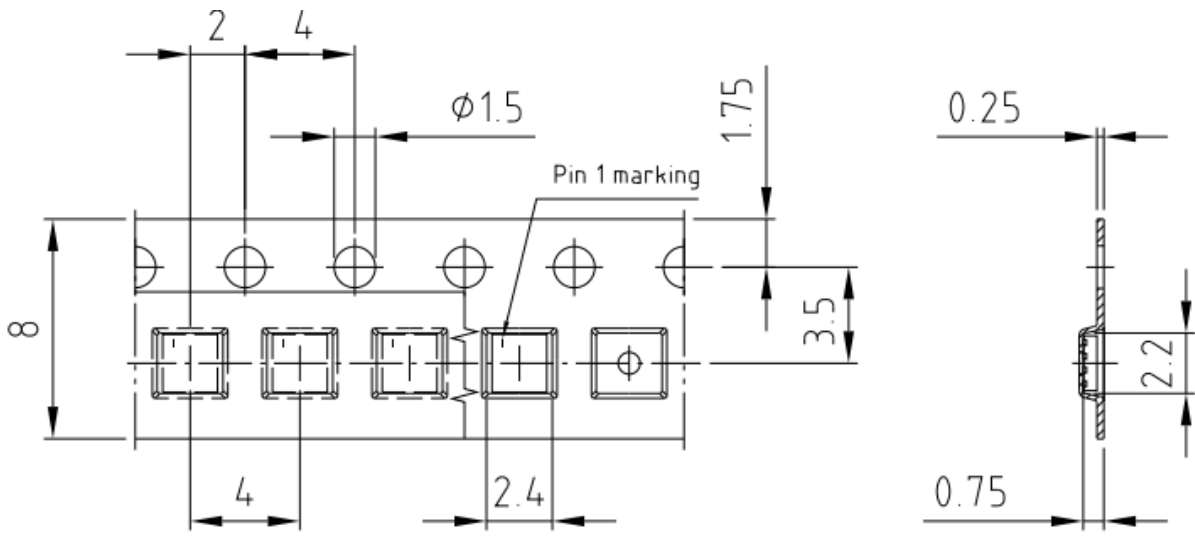

C63062-A4201-B6 -03

Tape and Reel ⁴⁾

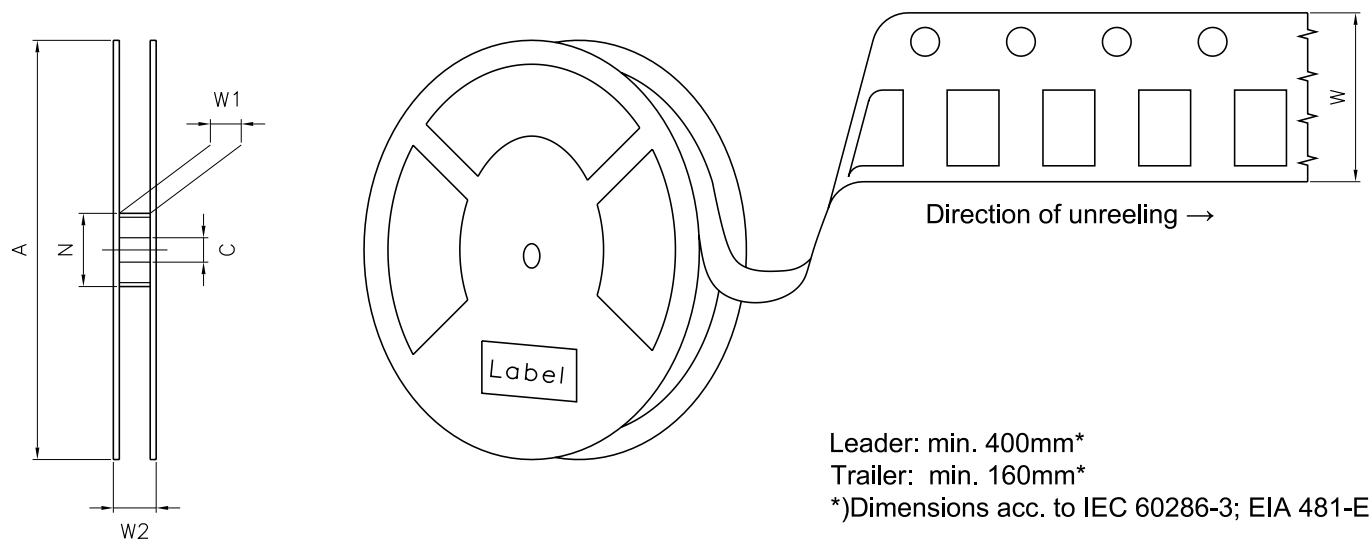

Reel Dimensions

A	W	N_{\min}	W_1	$W_{2\max}$	Pieces per PU
180 mm	$8 + 0.3 / - 0.1$ mm	60 mm	$8.4 + 2$ mm	14.4 mm	4000

Barcode-Product-Label (BPL)

OSRAM Opto Semiconductors LX XXXX BIN1: XX-XX-X-XXX-X

RoHS Compliant

(6P) BATCH NO: 1234567890

(1T) LOT NO: 1234567890 (9D) D/C: 1234

(X) PROD NO: 123456789 (Q) QTY: 9999 (G) GROUP: XX-XX-X-X

ML Temp ST
X XXX °C X

Pack: RXX
DEMY XXX
X_X123_1234.1234 X

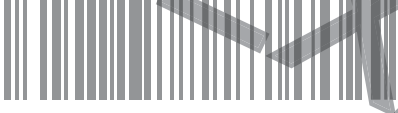

OHA04563

Dry Packing Process and Materials ³⁾

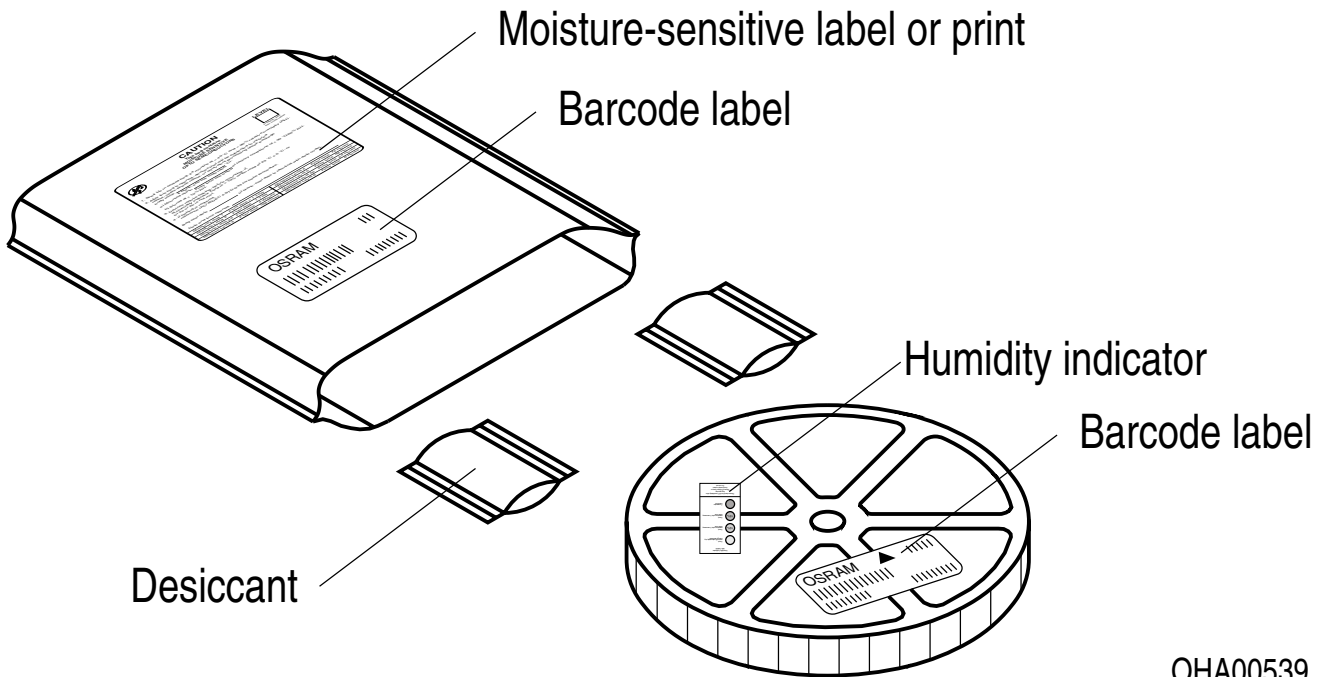

OHA00539

Discontinued

Notes

Subcomponents of this device contain, in addition to other substances, metal filled materials including silver. Metal filled materials can be affected by environments that contain traces of aggressive substances. Therefore, we recommend that customers minimize device exposure to aggressive substances during storage, production, and use. Devices that showed visible discoloration when tested using the described tests above did show no performance deviations within failure limits during the stated test duration. Respective failure limits are described in the IEC60810.

For further application related information please visit www.osram-os.com/appnotes

Disclaimer

Attention please!

The information describes the type of component and shall not be considered as assured characteristics. Terms of delivery and rights to change design reserved. Due to technical requirements components may contain dangerous substances.

For information on the types in question please contact our Sales Organization.

If printed or downloaded, please find the latest version on our website.

Packing

Please use the recycling operators known to you. We can also help you – get in touch with your nearest sales office. By agreement we will take packing material back, if it is sorted. You must bear the costs of transport. For packing material that is returned to us unsorted or which we are not obliged to accept, we shall have to invoice you for any costs incurred.

Product and functional safety devices/applications or medical devices/applications

Our components are not developed, constructed or tested for the application as safety relevant component or for the application in medical devices.

Our products are not qualified at module and system level for such application.

In case buyer – or customer supplied by buyer – considers using our components in product safety devices/ applications or medical devices/applications, buyer and/or customer has to inform our local sales partner immediately and we and buyer and /or customer will analyze and coordinate the customer-specific request between us and buyer and/or customer.

Glossary

- 1) **Typical Values:** Due to the special conditions of the manufacturing processes of semiconductor devices, the typical data or calculated correlations of technical parameters can only reflect statistical figures. These do not necessarily correspond to the actual parameters of each single product, which could differ from the typical data and calculated correlations or the typical characteristic line. If requested, e.g. because of technical improvements, these typ. data will be changed without any further notice.
- 2) **Testing temperature:** TA = 25°C (unless otherwise specified)
- 3) **Tolerance of Measure:** Unless otherwise noted in drawing, tolerances are specified with ± 0.1 and dimensions are specified in mm.
- 4) **Tape and Reel:** All dimensions and tolerances are specified acc. IEC 60286-3 and specified in mm.

Revision History

Version	Date	Change
1.2	2022-11-17	New Layout Discontinued

Discontinued



EU RoHS and China RoHS compliant product

此产品符合欧盟 RoHS 指令的要求；
按照中国的相关法规和标准，
不含有毒有害物质或元素。

Published by ams-OSRAM AG

Tobelbader Strasse 30, 8141 Premstaetten, Austria

Phone +43 3136 500-0

ams-osram.com

© All rights reserved

am 

OSRAM