

ILC6363

Step-Up DC-DC Converter for One-Cell Lithium-Ion Batteries

Features

- ILC6363CIR-50: Fixed 5.0V output; custom voltages are available upon request
- ILC6363CIR-ADJ: Adjustable output to 6V maximum
- Capable of 500mA output current
- Peak efficiency: > 90% at $V_{OUT} = 3.6V$, $I_{OUT} = 300mA$, $V_{IN} = 3.6V$
- No external diode is required (synchronous rectification)
- Battery input current of 300 μ A at no load
- True load disconnect from battery input in shutdown (1 μ A)
- Oscillator frequency: 300kHz \pm 15%
- Low battery detector with 100ms transient rejection delay
- Power good output flag when V_{OUT} is in regulation
- MSOP-8 package

Applications

- Cellular phones
- Palmtops, PDAs and portable electronics
- Equipment using single Lithium-Ion batteries

Description

The ILC6363 step-up/step-down DC-DC converter is a switch mode converter, capable of supplying up to 500mA output current, at a fixed or user selectable output voltage. The range of input, and output voltage options makes the ILC6363 ideal for Lithium-ion (Li-ion), or any other battery application, where the input voltage range spans above and below the regulated output voltage. When ILC6363's input

voltage exceeds the output voltage by more than 800mV, the output will begin to track the input linearly.

The ILC6363 is a direct replacement for ILC6360, in applications where SYNC pin is not used. The PFM or PWM operating mode is user selectable through SEL pin connected to ground or left open, respectively. The choice should be dependent upon the current to be delivered to the load: PFM is recommended for better efficiency at light load, while PWM is recommended for more than 50mA load current. In shutdown mode, the device allows true load disconnect from battery input.

Configured as a 300kHz, fixed frequency PWM/PFM boost converter, the ILC6363 can perform a limited buck operation in PFM mode, when the input voltage is up to 0.8V higher than the output voltage.

The ILC6363 is unconditionally stable with no external compensation; the sizes of the input and output capacitors influence input and output ripple voltages, respectively. Since the ILC6363 has an internal synchronous rectifier, the standard fixed voltage version requires minimal external components: an inductor, an input capacitor, and an output capacitor. If a tantalum output capacitor is used, then an additional 10 μ F ceramic output capacitor will help reduce output ripple voltage.

Other features include a low battery input detector with a built-in 100ms transient rejection delay and a power good indicator useful as a system power on reset.

Typical Circuit

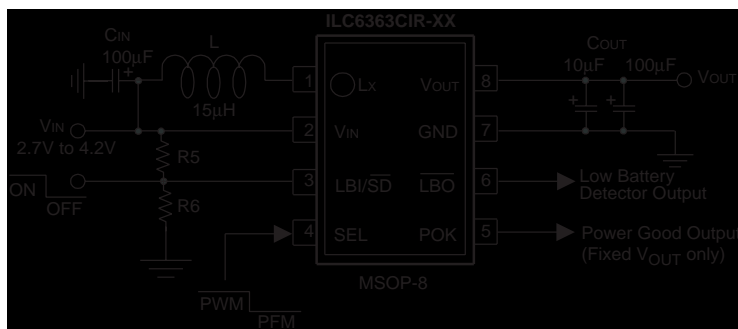
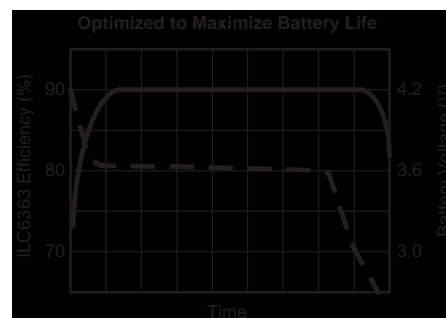

Figure 1.



Pin Assignments



Pin Definitions

Pin Number	Pin Name	Pin Function Description
1	L _X	Inductor input. Inductor L connected between this pin and the battery
2	V _{IN}	Input Voltage. Connect directly to battery
3	LBI/ $\overline{\text{SD}}$	Low battery detect input and shutdown. Low battery detect threshold is set with this pin using a potential divider. If this pin is pulled to logic low then the device will shutdown.
4	SEL	Select Input. A low logic level signal applied to this pin selects PFM operation mode. If the pin is left open or high logic level is applied, PWM mode is selected.
5	POK (ILC6363CIR-XX)	Power Good Output. This open drain output pin will go high when output voltage is within regulation, $0.92 \cdot V_{\text{OUT(NOM)}} \leq V_{\text{threshold}} \leq 0.98 \cdot V_{\text{OUT(NOM)}}$
	V _{FB} (ILC6363CIR-ADJ)	Feedback Input. This pin sets the adjustable output voltage via an external resistor divider network. The formula for choosing the resistors is shown in the “Applications Information” section.
6	LBO	Low Battery Output. This open drain output will go low if the battery voltage is below the low battery threshold set at pin 3.
7	GND	Ground of the IC. Connect this pin to the battery and system ground
8	V _{OUT}	Regulated output voltage.

Absolute Maximum Ratings

Parameter	Symbol	Ratings	Units
Voltage on V _{OUT} pin	V _{OUT}	-0.3 to 7	V
Voltage on LBI, Sync, $\overline{\text{LBO}}$, $\overline{\text{POK}}$, V _{FB} , L _X and V _{IN} pins		-0.3 to 7	V
Peak switch current on L _X pin	I _{LX}	1	A
Current on $\overline{\text{LBO}}$ pin	I _{SINK(LBO)}	5	mA
Continuous total power dissipation at 85°C	P _D	315	mW
Short circuit current	I _{SC}	Internally protected (1 sec. duration)	A
Operating ambient temperature	T _A	-40 to 85	°C
Maximum junction temperature	T _{J(MAX)}	150	°C
Storage temperature	T _{stg}	-40 to 125	°C
Lead temperature (soldering 10 sec.)		300	°C
Package thermal resistance	θ _{JA}	206	°C/W

Electrical Characteristics ILC6363CIR-50 in PFM Mode (SEL in LOW State)

Unless otherwise specified, all limits are at $V_{IN} = V_{LBI} = 3.6V$, $I_{OUT} = 1mA$ and $T_A = 25^{\circ}C$, test circuit Figure 1.

BOLDFACE type indicate limits over the specified operating temperature range. (Note 2)

Parameter	Symbol	Conditions	Min.	Typ.	Max.	Units
Output Voltage	$V_{OUT(nom)}$	$2.7V \leq V_{IN} \leq 4.2V$	4.875 4.825	5.0	5.125 5.175	V
Maximum Output Current	I_{OUT}	$V_{OUT} \geq 0.96V_{OUT(nom)}$, $V_{IN} = 2.7V$		250		mA
Load Regulation	$\frac{\Delta V_{OUT}}{V_{OUT}}$	$1mA \leq I_{OUT} \leq 50mA$		1		%
No Load Battery Input Current	$I_{IN (no load)}$	$I_{OUT} = 0mA$		300		μA
Efficiency	η	$I_{OUT} = 20mA$		85		%

Electrical Characteristics ILC6363CIR-50 in PWM Mode (SEL Open)

Unless otherwise specified, all limits are at $V_{IN} = V_{LBI} = 3.6V$, $I_{OUT} = 100mA$ and $T_A = 25^{\circ}C$, test circuit Figure 1.

BOLDFACE type indicate limits over the full operating temperature range. (Note 2)

Parameter	Symbol	Conditions	Min.	Typ.	Max.	Units
Output Voltage	$V_{OUT(nom)}$	$2.7V \leq V_{IN} \leq 4.2V$	4.850 4.800	5.0	5.150 5.200	V
Maximum Output Current	I_{OUT}	$V_{OUT} \geq 0.92V_{OUT(nom)}$		500		mA
Load Regulation	$\frac{\Delta V_{OUT}}{V_{OUT}}$	$50mA \leq I_{OUT} \leq 200mA$ $50mA \leq I_{OUT} \leq 300mA$		3 4		%
Efficiency	η	$I_{OUT} = 300mA$		92		%

General Electrical Characteristics

$T_A = 25^\circ\text{C}$, $V_{IN} = V_{LBI} = 3.6\text{V}$, $I_{OUT} = 50\text{mA}$, unless otherwise specified.

BOLDFACE indicate limits over the specified operating temperature range. (Note 2).

Parameter	Symbol	Conditions	Min.	Typ.	Max.	Units
LBO output voltage low	$V_{LBO(\text{low})}$	$I_{\text{SINK}} = 2\text{mA}$, open drain output, $V_{LBI} = 1\text{V}$			0.4	V
LBO output leakage current	$I_{LBO(\text{hi})}$	$V_{LBO} = 5\text{V}$		1	2	μA
Shutdown input voltage low	$V_{SD(\text{low})}$				0.4	V
Shutdown input voltage high	$V_{SD(\text{hi})}$		1		6	V
SEL input voltage high	$V_{SEL(\text{hi})}$		1.5			V
SEL input voltage low	$V_{SEL(\text{low})}$				0.4	V
POK output voltage low	$V_{POK(\text{low})}$	$I_{\text{SINK}} = 2\text{mA}$, open drain output			0.4	V
POK output voltage high	$V_{POK(\text{hi})}$				6	V
POK output leakage Current	$I_{L(\text{POK})}$	6V at pin 5			2	μA
POK threshold	$V_{TH(\text{POK})}$		$0.92 \times V_{OUT}$	$0.95 \times V_{OUT}$	$0.98 \times V_{OUT}$	V
POK hysteresis	V_{HYST}			50		mV
Feedback voltage (ILC6363CIR-ADJ only)	V_{FB}		1.225 1.212	1.250	1.275 1.288	V
Output voltage adjustment range (ILC6363CIR-ADJ only)	$V_{OUT(\text{ADJ}) \text{ min}}$ $V_{OUT(\text{ADJ}) \text{ max}}$	$V_{IN} = 0.9\text{V}$, $I_{OUT} = 50\text{mA}$ $V_{IN} = 3\text{V}$, $I_{OUT} = 50\text{mA}$		2.5 6		V
Minimum startup voltage	$V_{IN(\text{start})}$	$I_{OUT} = 10\text{mA}$, PWM mode		0.9	1	V
Input voltage range	V_{IN}	$V_{OUT} = V_{OUT(\text{nominal})} \pm 4\%$ $I_{OUT} = 10\text{mA}$	0.9 1		$V_{OUT(\text{nominal})} + 0.8\text{V}$	V
Battery input current in load disconnect mode	$I_{IN(\text{SD})}$	$V_{LBI/\text{SD}} < 0.4\text{V}$, $V_{OUT} = 0\text{V}$ (short circuit)		1	10	μA
Switch on resistance	$R_{ds(\text{on})}$	N-Channel MOSFET P-Channel MOSFET		400 750		$\text{m}\Omega$
Oscillator frequency	f_{osc}		255	300	345	kHz
LBI input threshold	V_{REF}		1.175 1.150	1.250	1.325 1.350	V
Input leakage current	I_{LEAK}	Pins LB/SD, SEL and VFB, (Note 3)			200	nA
LBI hold time	$t_{\text{HOLD(LBI)}}$	(Note 4)	100	120		mS

Notes:

- Absolute maximum ratings indicate limits which, when exceeded, may result in damage to the component. Electrical specifications do not apply when operating the device outside its rated operating conditions.
- Specified min/max limits are production tested or guaranteed through correlation based on statistical control methods. Measurements are taken at constant junction temperature as close to ambient temperature as possible using low duty cycle pulse testing.
- Guaranteed by design
- In order to get a valid low-battery-output (LBO) signal, the input voltage must be lower than the low-battery-input (LBI) threshold for a duration greater than the low battery hold time (Hold(LBI)). This feature eliminates false triggering due to voltage transients at the battery terminal.

Application Information

The ILC6363 performs boost DC-DC conversion by controlling the switch element as shown in the simplified circuit in Figure 3 below.

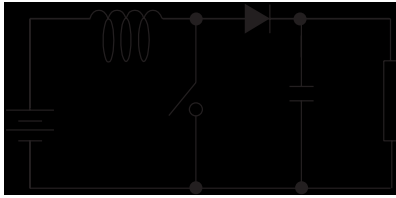

Figure 3. Basic Boost Circuit

When the switch is closed, current is built up through the inductor. When the switch opens, this current is forced through the diode to the output. As this on and off switching continues, the output capacitor voltage builds up due to the charge it is storing from the inductor current. In this way, the output voltage is boosted relative to the input.

In general, the switching characteristic is determined by the output voltage desired and the current required by the load. The energy transfer is determined by the power stored in the coil during each switching cycle.

$$P_L = f(t_{ON}, V_{IN})$$

Synchronous Rectification

The ILC6363 also uses a technique called “synchronous rectification” which removes the need for the external diode used in other circuits. The diode is replaced with a second switch or in the case of the ILC6363, an FET as shown in Figure 4 below.

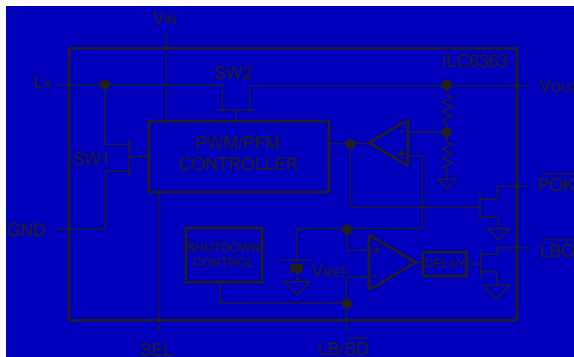

Figure 4. Simplified ILC6383 block diagram

The two switches now open and close in opposition to each other, directing the flow of current to either charge the inductor or to feed the load. The ILC6363 monitors the voltage on the output capacitor to determine how much and how often to drive the switches.

PWM Mode Operation

The ILC6363 uses a PWM or Pulse Width Modulation technique. The switches are constantly driven at typically 300kHz. The control circuitry varies the power being delivered to the load by varying the on-time, or duty cycle, of the switch SW1 (see Figure 5). Since more on-time translates to higher current build-up in the inductor, the maximum duty cycle of the switch determines the maximum load current that the device can support. The minimum value of the duty cycle determines the minimum load current that can maintain the output voltage within specified values.

There are two key advantages of the PWM type controllers. First, because the controller automatically varies the duty cycle of the switch's on-time in response to changing load conditions, the PWM controller will always have an optimized waveform for a steady-state load. This translates to very good efficiency at high currents and minimal ripple on the output. Ripple is due to the output cap constantly accepting and storing the charge received from the inductor, and delivering charge as required by the load. The “pumping” action of the switch produces a sawtooth-shaped voltage as seen by the output.

The other key advantage of the PWM type controllers over pulse frequency modulated (PFM) types is that the radiated noise due to the switching transients will always occur at (fixed) switching frequency. Many applications do not care much about switching noise, but certain types of applications, especially communication equipment, need to minimize the high frequency interference within their system as much as possible. Use of the PWM converter in those cases is desirable.

PFM Mode Operation

For light loads the ILC6363 can be switched to PFM. This technique conserves power by only switching the output if the current drain requires it. As shown in the Figure 5, the waveform actually skips pulses depending on the power needed by the output. This technique is also called “pulse skipping” because of this characteristic.

In the ILC6363, the switchover from PWM to PFM mode is determined by the user to improve efficiency and conserve power.

The Dual PWM/PFM mode architecture was designed specifically for applications such as wireless communications, which need the spectral predictability of a PWM-type DC-DC converter, yet also need the highest efficiencies possible, especially in Standby mode.

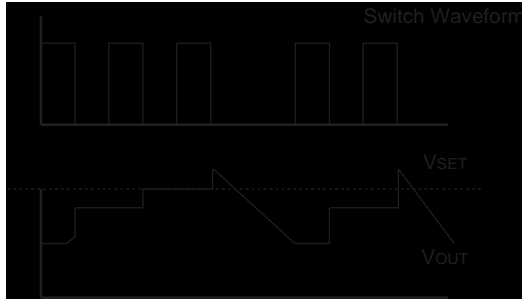

Figure 5. PFM Waveform

Other Considerations

The other limitation of PWM techniques is that, while the fundamental switching frequency is easier to filter out since it's constant, the higher order harmonics of PWM will be present and may have to be filtered out, as well. Any filtering requirements, though, will vary by application and by actual system design and layout, so generalizations in this area are difficult, at best.

However, PWM control for boost DC-DC conversion is widely used, especially in audio-noise sensitive applications or applications requiring strict filtering of the high frequency components.

Low Battery Detector

The ILC6363's low battery detector is based on a CMOS comparator. The negative input of the comparator is tied to an internal 1.25V (nominal) reference, V_{REF} . The positive input is the LBI/SD pin. It uses a simple potential divider arrangement with two resistors to set the LBI threshold as shown in Figure 6. The input bias current of the LBI pin is only 200nA. This means that the resistor values R1 and R2 can be set quite high. The formula for setting the LBI threshold is:

$$V_{LBI} = V_{REF} \times (1 + R5/R6)$$

Since the LBI input current is negligible (<200nA), this equation is derived by applying voltage divider formula across R6. A typical value for R6 is 100kΩ.

$$R5 = 100k\Omega \times [(V_{LBI}/V_{REF}) - 1],$$

where $V_{REF}=1.25V$ (nom.)

The LBI detector has a built in delay of 120ms. In order to get a valid low-battery-output (LBO) signal, the input voltage must be lower than the low-battery-input (LBI) threshold for a duration greater than the low battery hold time ($t_{hold(LBI)}$) of 120msec. This feature eliminates false triggering due to voltage transients at the battery terminal caused by high frequency switching currents.

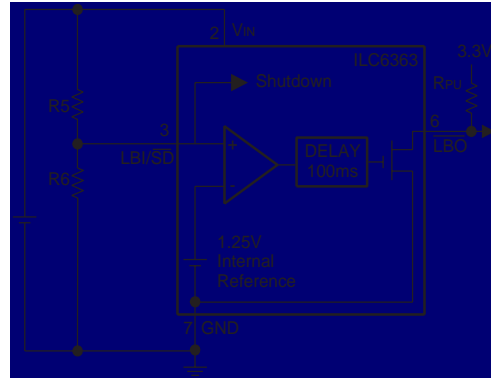

Figure 6. Low Battery Detector

The output of the low battery detector is an open drain capable of sinking 2mA. A 10kΩ pull-up resistor is recommended on this output.

For $V_{LBI} < 1.25V$

The low battery detector can also be configured for voltages <1.25V by bootstrapping the LBI input from V_{OUT} . The circuitry for this is shown in Figure 7.

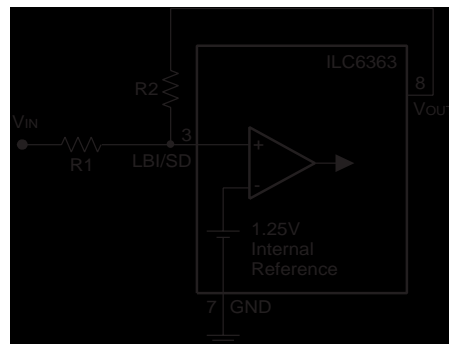

Figure 7. $V_{LBI} < 1.25V$

The following equation is used when V_{IN} is lower than 1.25V:

$$R1 = R2 \times [(V_{REF} - V_{IN}) / (V_{OUT} - V_{REF})],$$

where $V_{REF} = 1.25V$ (nom.)

This equation can also be derived using voltage divider formula across R2. A typical value for R2 is 100kΩ.

Shut Down

The LBI pin is shared with the shutdown pin. A low voltage (<0.4V) will put the ILC6363 into a power down state. The simplest way to implement this is with an FET across R6 as shown in Figure 8. Note that when the device is not in PWM mode or is in shutdown the low battery detector does not operate.

When the ILC6363 is shut down, the synchronous rectifier disconnects the output from the input. This ensures that there is only leakage ($I_{IN} < 1\mu A$ typical) from the input to the output so that the battery is not drained when the ILC6363 is shut down.

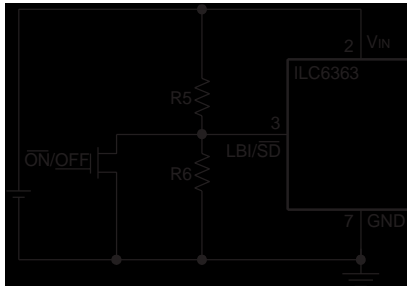

Figure 8. Shut Down Control

Power Good Output (POK)

The \overline{POK} output of the ILC6363 indicates when V_{OUT} is within the regulation tolerance of the set output voltage. \overline{POK} output is an open drain device output capable of sinking 2mA. It will remain pulled low until the output voltage has risen to typically 95% of the specified V_{OUT} . Note that a pull-up resistor must be connected from the \overline{POK} output (pin 5 of ILC6363CIR-XX) to either ILC6363’s output or to some other system voltage source.

Adjustable Output Voltage Selection

The ILC6363-ADJ allows the output voltage to be set using a potential divider. The formula for setting the adjustable output voltage is;

$$V_{OUT} = V_{FB} \times (1 + R1/R2), R1 + R2 \leq 100k\Omega$$

Where V_{FB} is the threshold set which is 1.25V nominal.

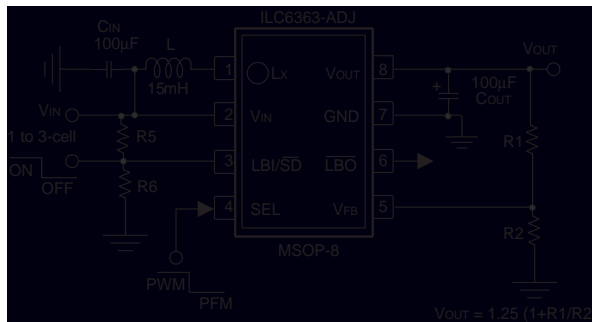

Figure 9. Adjustable Voltage Configuration

Negative Voltage Output

It is possible to generate a negative output voltage as a secondary supply using the ILC6363. This negative voltage may be useful in some applications where a negative bias voltage at low current is required.

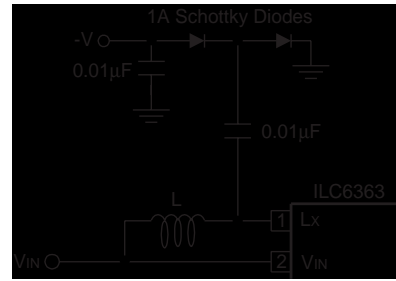

Figure 10. Negative Output Voltage

External Component Selection

Inductors

The ILC6363 is designed to work with a 15µH inductor in most applications. There are several vendors who supply standard surface mount inductors to this value. Suggested suppliers are shown in table 1. Higher values of inductance will improve efficiency, but will reduce peak inductor current and consequently ripple and noise, but will also limit output current.

Vendor	Part Number	Contact
Coilcraft	D03316P-153 D01608C-153	(847) 639-6400
muRata	LQH4N150K LQH3C150K	(814) 237-1431
Sumida	CDR74B-150MC CD43-150 CD54-150	(847) 956-0666
TDK	NLC453232T-150K	(847) 390-4373

Capacitors

Input Capacitor

The input capacitor is necessary to minimize the peak current drawn from the battery. Typically a 100µF tantalum capacitor is recommended. Low equivalent series resistance (ESR) capacitors will help to minimize battery voltage ripple.

Output Capacitor

Low ESR capacitors should be used at the output of the ILC6363 to minimize output ripple. The high switching speeds and fast changes in the output capacitor current, mean that the equivalent series impedance of the capacitor can contribute greatly to the output ripple. In order to minimize these effects choose an output capacitor with less than 10nH of equivalent series inductance (ESL) and less than 100mΩ of equivalent series resistance (ESR). Typically these characteristics are met with ceramic capacitors, but may also be met with certain types of tantalum capacitors. Suitable vendors are shown in the following table.

Description	Vendor	Contact
T495 series tantalum	Kemet	(864) 963-6300
595D series tantalum	Sprague	(603) 224-1961
TAJ, TPS series tantalum	AVX	(803) 946-0690
X5R Ceramic X7R Ceramic	TDK	(847) 390-4373
	AVX	(803) 946-0690
	muRata	www.murata.com

Layout and Grounding Considerations

High frequency switching and large peak currents means PCB design for DC-DC converters requires careful consideration. As a general rule place the DC-DC converter circuitry well away from any sensitive RF or analog components. The layout of the DC-DC converters and its external components are also based on some simple rules to minimize EMI and output voltage ripple.

Layout

1. Place all power components, ILC6363, inductor, input capacitor and output capacitor as close together as possible.
2. Keep the output capacitor as close to the ILC6363 as possible with very short traces to the V_{OUT} and GND pins. Typically it should be within 0.25 inches or 6mm.

3. Keep the traces for the power components wide, typically >50mil or 1.25mm.
4. Place the external networks for LBI and VFB close to the ILC6363, but away from the power components as far as possible.

Grounding

1. Use a star grounding system with separate traces for the power ground and the low power signals such as LBI/ \overline{SD} and VFB. The star should radiate from where the power supply enters the PCB.
2. On multilayer boards use component side copper for grounding around the ILC6363 and connect back to a quiet ground plane using vias.

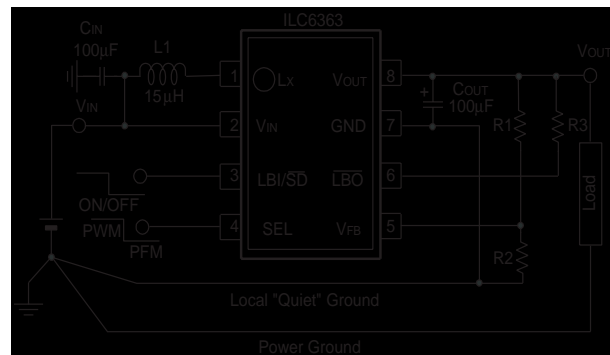
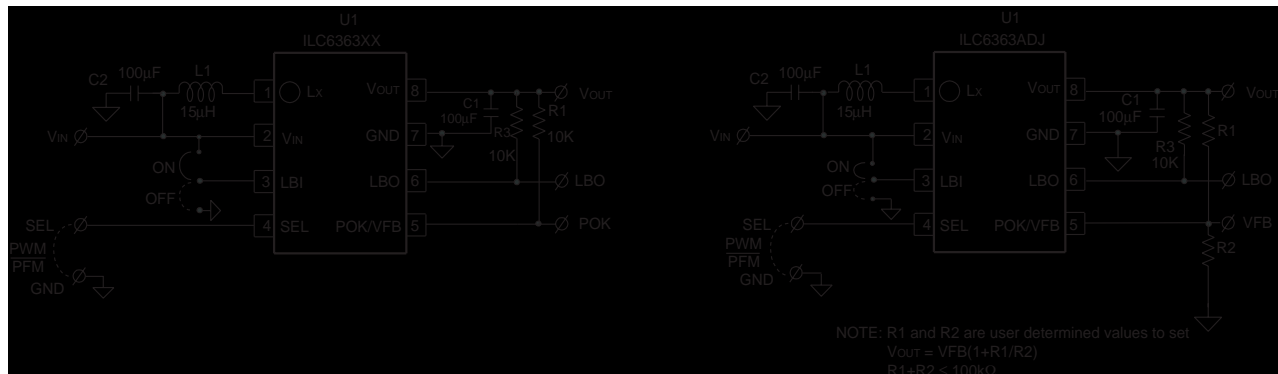
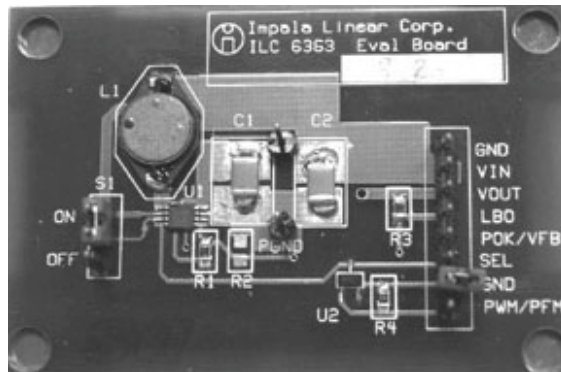

Figure 11. Recommended Application Circuit Schematic for ILC6363CIR-ADJ



Evaluation Board Parts List for Printed Circuit Board Shown on the Previous Page

Label	Part Number	Manufacturer	Description
U1	ILC6363CIR-ADJ	Fairchild Semiconductor	DC-DC converter
C	GRM44-1 X5R 107K 6.3	muRata	100 μ F, ceramic capacitor
L1	LQS66C150M04	muRata	15 μ H, 1.3A
R1 and R2	—	Dale, Panasonic	User determined values
R3	—	Dale, Panasonic	10k Ω , 1/10W, SMT

Label	Part Number	Manufacturer	Description
U1	ILC6363CIR-XX	Fairchild Semiconductor	DC-DC converter
C	GRM44-1 X5R 107K 6.3	muRata	100 μ F, ceramic capacitor
L1	LQS66CA150M04	muRata	15 μ H, 1.3A
R1 and R3	-	Dale, Panasonic	10k Ω , 1/10W, SMT

Typical Performance Characteristics ILC6363CIR-ADJ

Unless otherwise specified: $T_A = 25^\circ\text{C}$, $C_{IN} = 100\mu\text{F}$, $C_{OUT} = 100\mu\text{F}$, $L = 15\mu\text{H}$, $V_{OUT} = 3.6\text{V}$

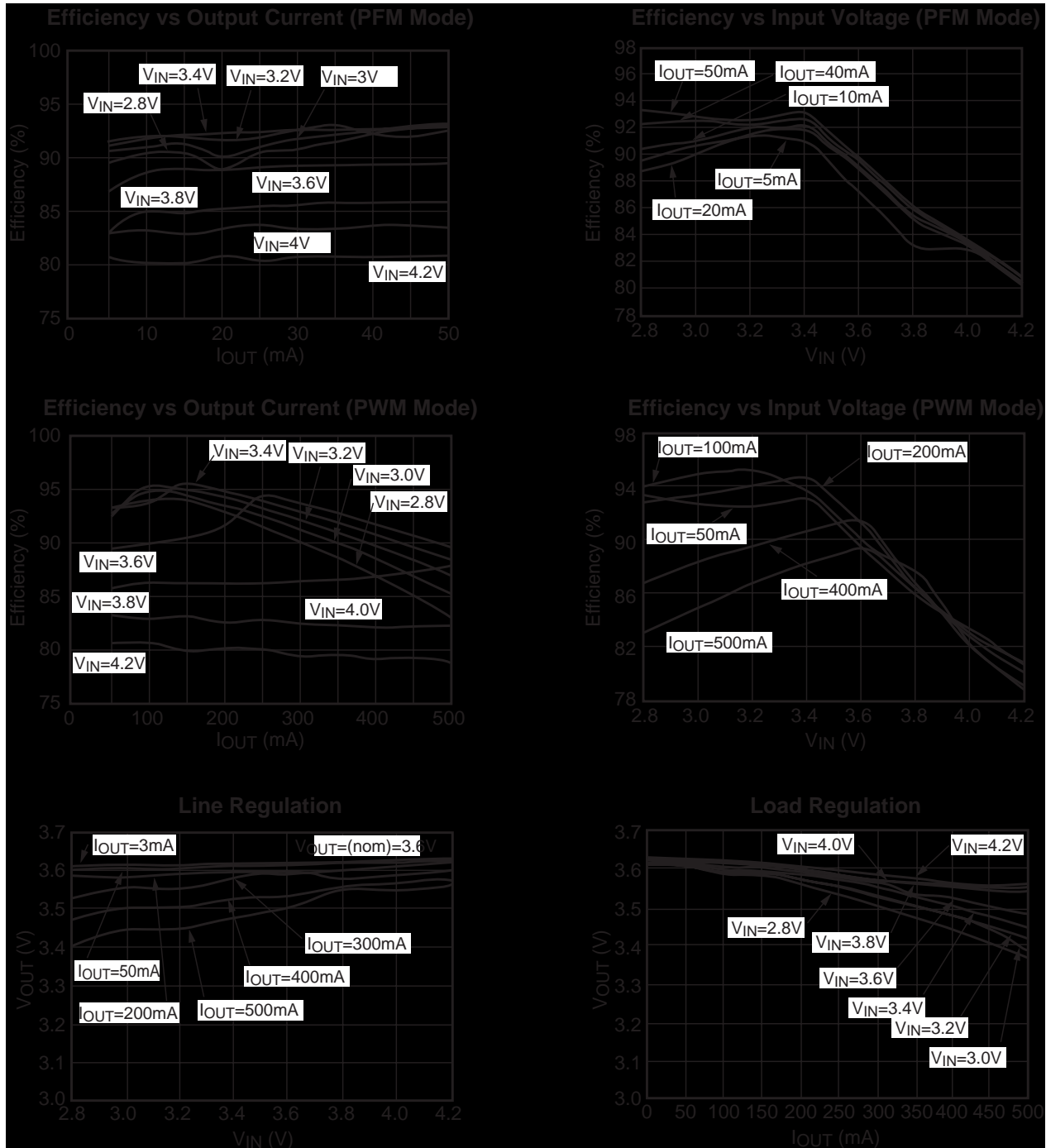

Typical Performance Characteristics ILC6363CIR-ADJ

Unless otherwise specified: $T_A = 25^\circ\text{C}$, $C_{IN} = 100\mu\text{F}$, $C_{OUT} = 100\mu\text{F}$, $L = 15\mu\text{H}$, $V_{OUT} = 3.6\text{V}$

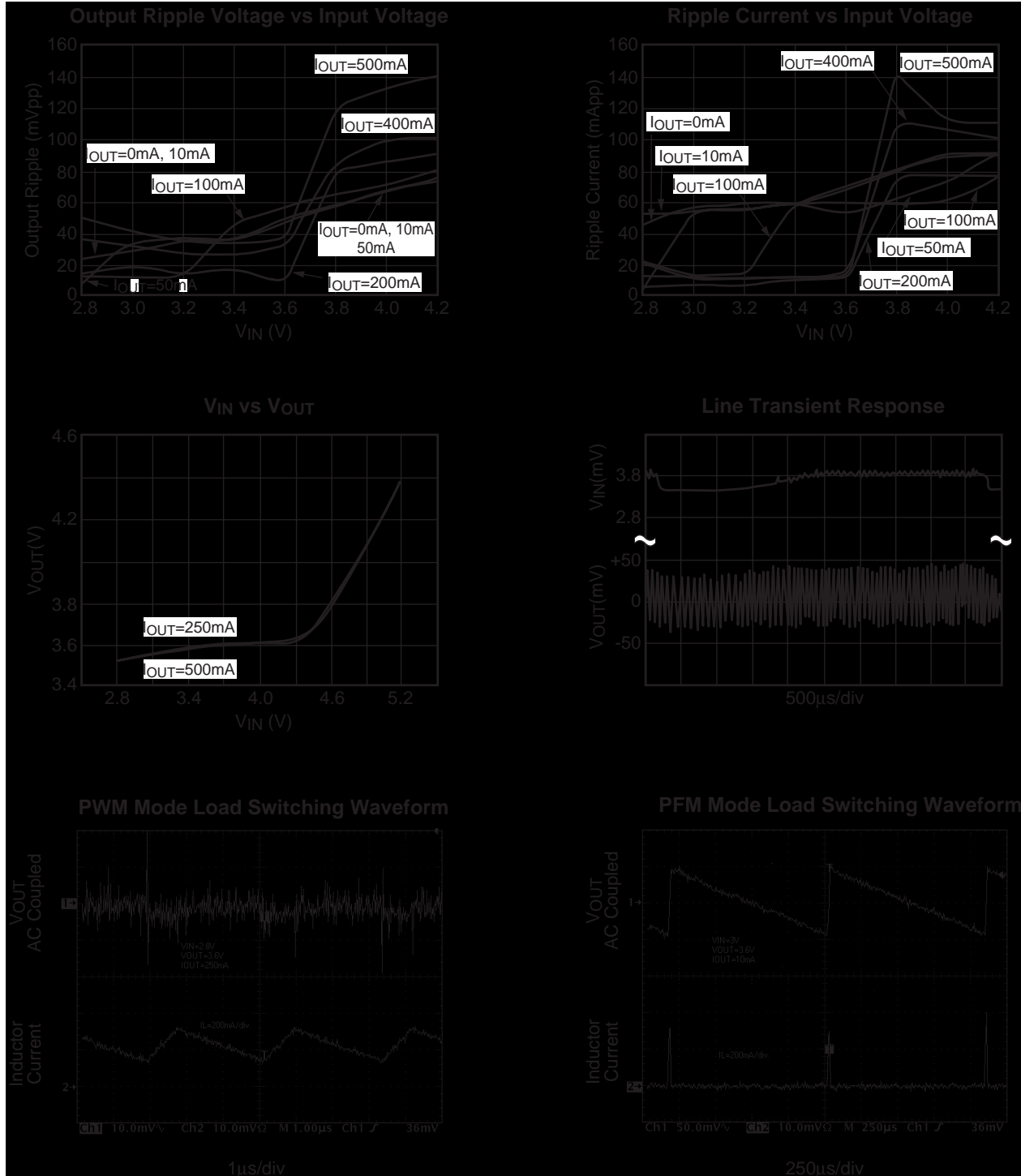

Typical Performance Characteristics ILC6363CIR-ADJ

Unless otherwise specified: $T_A = 25^\circ\text{C}$, $C_{IN} = 100\mu\text{F}$, $C_{OUT} = 100\mu\text{F}$, $L = 15\mu\text{H}$, $V_{OUT} = 3.6\text{V}$ (nominal)

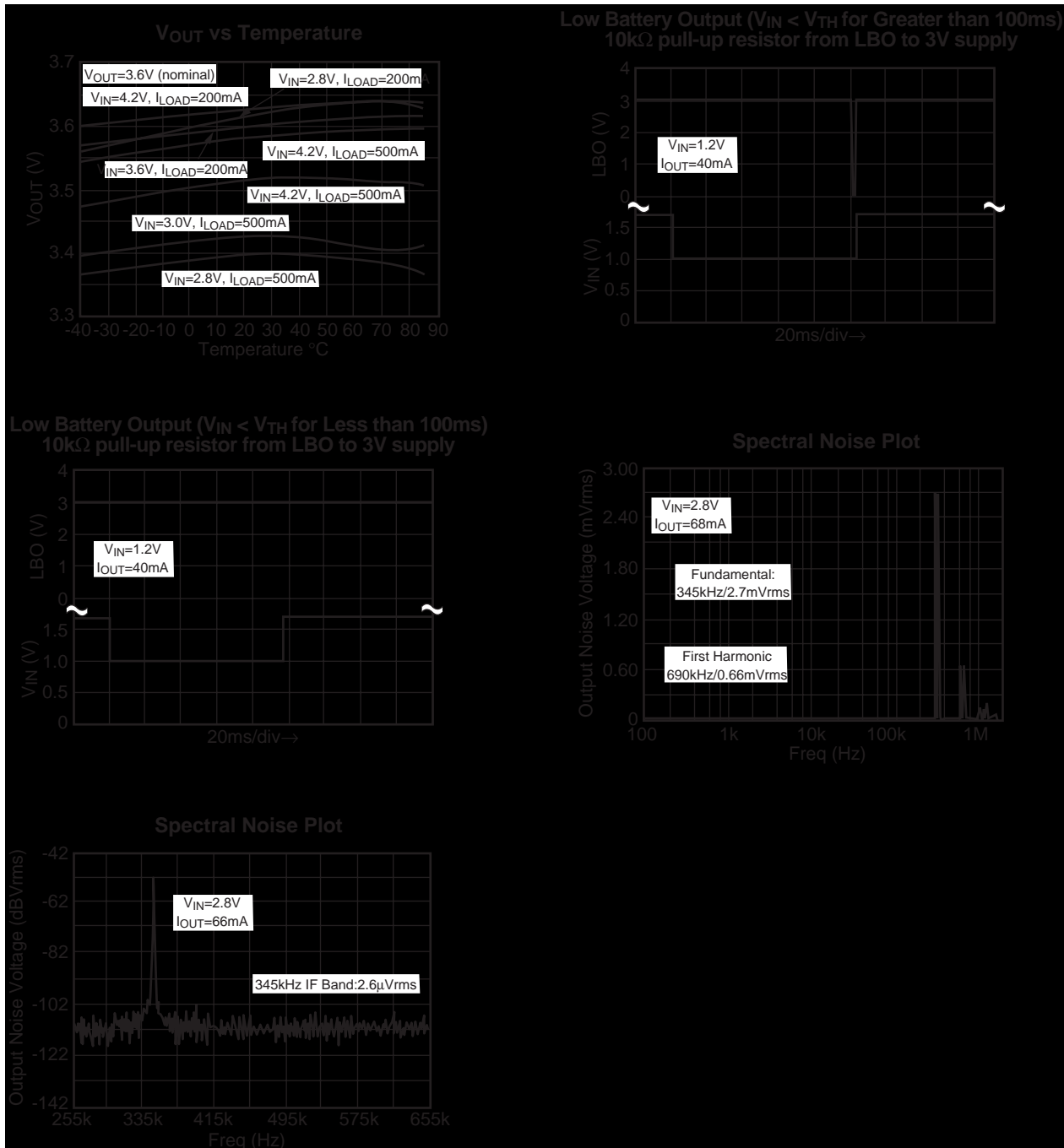

Mechanical Dimensions

8 Lead MSOP

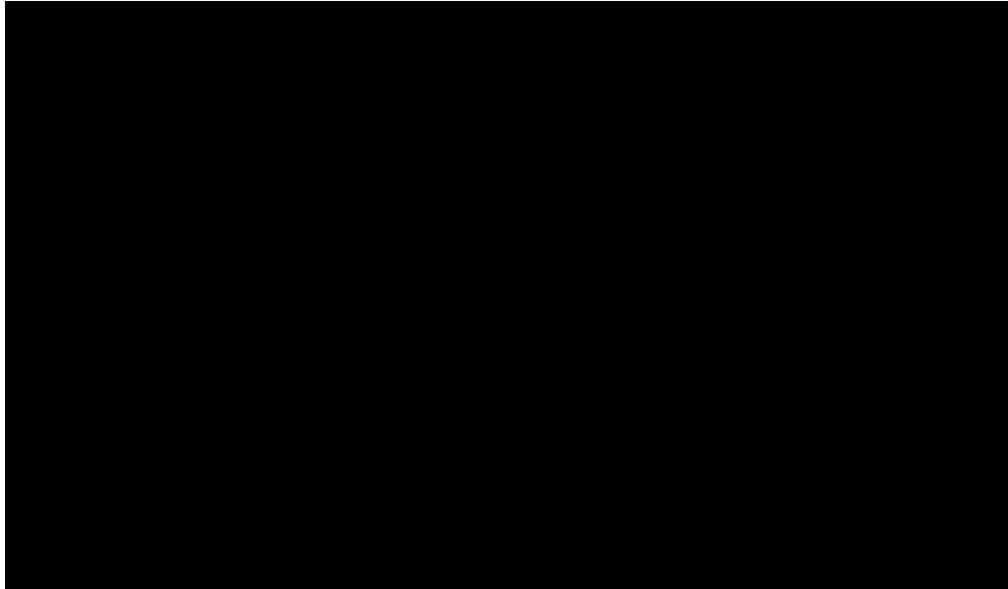

Ordering Information for $T_a = -40^{\circ}\text{C}$ to $+85^{\circ}\text{C}$, MSOP-8 Package

Part Number	Output Voltage
ILC6363CIR50X	5.0
ILC6363CIRADJX	Adjustable

DISCLAIMER

FAIRCHILD SEMICONDUCTOR RESERVES THE RIGHT TO MAKE CHANGES WITHOUT FURTHER NOTICE TO ANY PRODUCTS HEREIN TO IMPROVE RELIABILITY, FUNCTION OR DESIGN. FAIRCHILD DOES NOT ASSUME ANY LIABILITY ARISING OUT OF THE APPLICATION OR USE OF ANY PRODUCT OR CIRCUIT DESCRIBED HEREIN; NEITHER DOES IT CONVEY ANY LICENSE UNDER ITS PATENT RIGHTS, NOR THE RIGHTS OF OTHERS.

LIFE SUPPORT POLICY

FAIRCHILD'S PRODUCTS ARE NOT AUTHORIZED FOR USE AS CRITICAL COMPONENTS IN LIFE SUPPORT DEVICES OR SYSTEMS WITHOUT THE EXPRESS WRITTEN APPROVAL OF THE PRESIDENT OF FAIRCHILD SEMICONDUCTOR CORPORATION. As used herein:

1. Life support devices or systems are devices or systems which, (a) are intended for surgical implant into the body, or (b) support or sustain life, and (c) whose failure to perform when properly used in accordance with instructions for use provided in the labeling, can be reasonably expected to result in a significant injury of the user.
2. A critical component in any component of a life support device or system whose failure to perform can be reasonably expected to cause the failure of the life support device or system, or to affect its safety or effectiveness.

Fairchild Semiconductor

SEARCH | [Parametric](#) | [Cross Reference](#) [Product Folders and](#) [Appliea](#)[find products](#)[Home >> Find products >>](#)[Products groups](#)[Analog and Mixed](#)[Signal](#)[Discrete](#)[Interface](#)[Logic](#)[Microcontrollers](#)[Non-Volatile](#)[Memory](#)[Optoelectronics](#)[Markets and](#)[applications](#)[New products](#)[Product selection and](#)[parametric search](#)[Cross-reference](#)[search](#)[technical information](#)[buy products](#)[technical support](#)[my Fairchild](#)[company](#)

ILC6363CIR33

Product information

Contents

[General description](#) | [Features](#) | [Applications](#) | [Product status/pricing/packaging](#)

General description

The ILC6363 step-up/step-down DC-DC converter is a switch mode converter, capable of supplying up to 500mA output current, at a fixed or user selectable output voltage. The range of input, and output voltage options makes the ILC6363 ideal for Lithium-ion (Li-ion), or any other battery application, where the input voltage range spans above and below the regulated output voltage. When ILC6363's input voltage exceeds the output voltage by more than 800mV, the output will begin to track the input linearly.

The ILC6363 is a direct replacement for ILC6360, in applications where SYNC pin is not used. The PFM or PWM operating mode is user selectable through SEL pin connected to ground or left open, respectively. The choice should be dependent upon the current to be delivered to the load: PFM is recommended for better efficiency at light load, while PWM is recommended for more than 50mA load current. In shutdown mode, the device allows true load disconnect from battery input.

Configured as a 300kHz, fixed frequency PWM/PFM boost converter, the ILC6363 can perform a limited buck operation in PFM mode, when the input voltage is up to 0.8V higher than the output voltage.

The ILC6363 is unconditionally stable with no external compensation; the sizes of the input and output capacitors influence input and output ripple voltages, respectively. Since the ILC6363 has an internal synchronous rectifier,

Datasheet

[Download this datasheet](#)[PDF](#)[e-mail this datasheet](#)[\[E-\]](#)This page [Print version](#)[Related Links](#)[Request samples](#)[Dotted line](#)[How to order products](#)[Dotted line](#)[Product Change Notices](#)[\(PCNs\)](#)[Dotted line](#)[Support](#)[Dotted line](#)[Distributor and field sales](#)[representatives](#)[Dotted line](#)[Quality and reliability](#)[Dotted line](#)[Design tools](#)

the standard fixed voltage version requires minimal external components: an inductor, an input capacitor, and an output capacitor. If a tantalum output capacitor is used, then an additional 10 μ F ceramic output capacitor will help reduce output ripple voltage.

Other features include a low battery input detector with a built-in 100ms transient rejection delay and a power good indicator useful as a system power on reset.

[back to top](#)

Features

- ILC6363CIR-50: Fixed 5.0V output; custom voltages possible
- ILC6363CIR-ADJ: Adjustable output to 6V maximum
- Capable of 500mA output current
- Peak efficiency: > 90% at $V_{OUT} = 3.6V$, $I_{OUT} = 300mA$, $V_{IN} = 3.6V$
- No external diode is required (synchronous rectification)
- Battery input current of 300 μ A at no load
- True load disconnect from battery input in shutdown (1 μ A)
- Oscillator frequency: 300kHz \pm 15%
- Low battery detector with 100ms transient rejection delay
- Power good output flag when V_{OUT} is in regulation
- MSOP-8 package

[back to top](#)

Applications

- Cellular phones
- Palmtops, PDAs and portable electronics
- Equipment using single Lithium-Ion batteries

[back to top](#)

Product status/pricing/packaging

Product	Product status	Pricing*	Package marking	Packing method
ILC6363CIR33X	Full Production	\$1.80	\$Y&Z&2&T 6363C F	TAPE REEL

* 1,000 piece Budgetary Pricing

[back to top](#)

[Home](#) | [Find products](#) | [Technical information](#) | [Buy products](#) |
[Support](#) | [Company](#) | [Contact us](#) | [Site index](#) | [Privacy policy](#)

© Copyright 2002 Fairchild Semiconductor