

PART NUMBER	REVISION	DESCRIPTION	FEED TYPE
2150582-2	D	FINE CRIMP HEIGHT ADJUST	PNEUMATIC
7-2150582-2	D	PNEUMATIC AND CRIMP TOOLING KIT	PNEUMATIC
7-2150582-7	A	CRIMP TOOLING KIT	-

ATLANTIC VERSION TERMINATOR INTERFACE ADAPTER

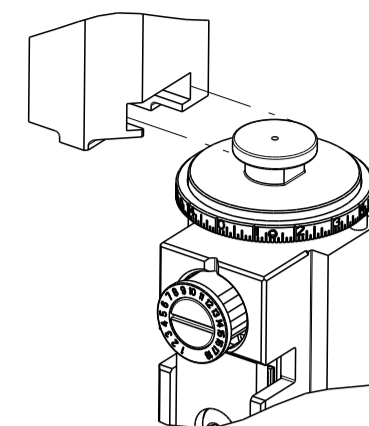

APPLICATOR DATA		
CRIMP	SIZE	TYPE
WIRE	3.81 mm [.150]	F
INSUL	6.35 mm [.250]	F
APPL INSTRUCTIONS 408-35043		

TERMINAL DATA: TE TERMINAL		TE CRIMP SPECIFICATION	
TERMINAL NAME: 250 SERIES AUTOMOTIVE POSITIVE LOCK RECEP.			
WIRE STRIP LENGTH		INSULATION DIAMETER RANGE	
4.20-5.20 mm [.165-.205 IN]		∅3.60-5.00 mm [.142-.197 IN]	
TERMINAL APPLICATION SPECIFICATION	114-5060	-	-
TERMINALS APPLIED			
TE TERMINAL	TE TERMINAL	TE TERMINAL	TE TERMINAL
170456-1	170456-2		

WIRE SIZE	CRIMP HEIGHT mm [INCH]	CRIMP HEIGHT REFERENCE SETTING
10 AWG	2.62 +/- 0.05 [1.103 +/- .002]	5.9
5.00mm2	2.62 +/- 0.05 [1.103 +/- .002]	5.9
12 AWG	2.20 +/- 0.05 [1.087 +/- .002]	10.1
3.00mm2	2.20 +/- 0.05 [1.087 +/- .002]	10.1

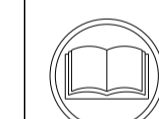

- RECOMMENDED SPARE PARTS
- REFER TO SUPPLIED INSTRUCTION SHEET FOR CLEANING, LUBRICATION AND STORAGE OF APPLICATOR.
- APPLY PART NUMBER 2-23419-6 LOCTITE TO THREADS OF ITEM 242.
- CRIMP HEIGHT REFERENCE SETTING WAS THE SETTING USED WHEN THE APPLICATOR WAS QUALIFIED AT THE FACTORY. ADJUSTMENT MAY BE NECESSARY WHEN RUNNING APPLICATOR IN THE FIELD.
- TERMINAL PITCH NOT COMPATIBLE WITH MECHANICAL FEED.
- 6. UNLESS SPECIFIED OTHERWISE TORQUE VALUES SHALL BE USED PER DOCUMENT, 101-35000.

***WARNING**
ON INSTALLATION, SET WIRE DISC TO CRIMP HEIGHT REFERENCE SETTING FOR LARGEST WIRE SIZE. CRIMP HEIGHT REFERENCE SETTINGS GREATER THAN THE VALUE SHOWN MAY CAUSE DAMAGE TO THE CRIMP TOOLING. REFER TO THE INSTRUCTION SHEET FOR PROPER SETUP AND ADJUSTMENTS.

LOC	DIST	REVISIONS					
A	66	P	LTN	DESCRIPTION	DATE	OWN	APVD
		A		RELEASED	10JUL2015	GH	GB
		B		ECR-17-009277	26JUN2017	TB	GB
		C		ECR-19-005140	30MAR2019	TB	CT
		D		ECR-21-123364	07DEC2021	JWC	TE

-	1	1	2119641-1	FEED CAM, AIR FEED	248
-	1	1	2119082-3	CAM, SNAIL, INSULATION ADJUSTMENT	244
-	1	1	2079764-1	WASHER, WAVE SPRING, CREST-TO-CREST	243
-	1	1	2119083-1	RETAINER, INSULATION DIAL	242
-	1	1	2844940-4	AIR FEED MODULE	238
-	1	1	1-18028-0	WASHER, FLAT, REG M8	192
-	REFREF		994970-2	COUNTER, MAGNETIC	164
-	1	1	455888-4	SPACER, CRIMPER	82
-	1	1	1803607-4	DOCUMENTATION PACKAGE	71
-	2	2	2-18032-2	SCR, SET, FLT PNT, M3 X 10.0	70
-	1	1	2119740-1	TAG, IDENTIFICATION	67
-	2	2	2168078-1	SCREW, DRIVE, RH, RoHS, 2 x .188	66
-	1	1	2168083-2	SCR, SKT HD CAP, RoHS, M4 X 8.0	60
-	1	1	5-18022-5	SCR, HEX HD CAP, M4 X 6.0	59
-	4	4	2168400-4	SHCS, LOW HEAD, RoHS, M4 X 8	57
-	2	2	2168083-8	SCR, SKT HD CAP, RoHS, M4 X 16	56
-	2	2	5018030-1	NUT, HEX, REG, RoHS, M3	54
-	2	2	986965-8	NUT, LOCK, HEX, TORQUE (M4)	53
-	1	1	2063961-1	FEED FINGER	51
-	1	1	18023-9	SCR, SKT HD CAP M4 X 6.0	49
-	1	1	2119655-5	APPLICATOR BASIC ASSEMBLY, EF	46
-	1	1	1803517-1	RAM ASSEMBLY, EF ATLANTIC	44
-	1	1	1803602-1	SCR, BHSC, RoHS (M8 X 25)	41
-	8	8	1-18028-2	WASHER, FLAT, REG M4	33
-	2	2	2168083-9	SCR, SKT HD CAP, RoHS, M4 X 20	31
-	2	2	2168083-2	SCR, SKT HD CAP, RoHS, M4 X 8.0	29
-	1	1	690455-1	STRIPPER, FRONT CASTING	27
-	2	2	1-2168083-5	SCR, SKT HD CAP, RoHS, M4 X 30	25
-	1	1	1752371-5	PLATE, STRIP GUIDE	24
-	2	2	22281-9	SPRING, COMPRESSION	22
-	1	1	1803292-4	DRAG	20
-	2	2	1901259-7	GUIDE, LOWER STRIP	18
-	4	4	1-2079383-1	SCR, BHSC, RoHS (M6 X 12)	17
-	1	1	240644-1	PLATE, REAR SHEAR	11
-	-	-	-	-	10
-	1	1	690482-4	PLATE, FRONT SHEAR	9
-	1	2	1-1803074-4	ANVIL, COMBINATION, END FEED	8
-	1	1	1-2217206-0	BLADE, SLUG	7
-	-	-	-	-	6
-	1	1	5-240641-5	SPACER	5
-	1	1	1-238011-0	BLOCK, CRIMPER SPACER	4
-	1	2	1-1803016-6	CRIMPER, INSULATION F	3
-	1	1	455888-5	SPACER, CRIMPER	2
-	1	2	1-1633609-8	CRIMPER, WIRE	1
-	77	72	-2	PART NO	ITEM NO

ATLANTIC VERSION
Shown on sheets 1 of 4 & 2 of 4
(Pacific version shown on sheets 3 of 4 & 4 of 4)

DIMENSIONS:		TOLERANCES UNLESS OTHERWISE SPECIFIED:		APPROVED:		NAME:	
mm	0 PLC ±	1 PLC ±	2 PLC ±	3 PLC ±	4 PLC ±	APVD	NAME
	ANGLES	FINISH					
MATERIAL		WEIGHT		SIZE	CAGE CODE	DRAWING NO	RESTRICTED TO
				A1	00779	2150582	
Customer Accessible Production Drawing				SCALE	1:1	SHEET	1 of 4
				REV	D		

LOC	DIST	REVISIONS			
P	LTN	DESCRIPTION	DATE	DMN	APVD
A	66	SEE SHEET 1	-	-	-

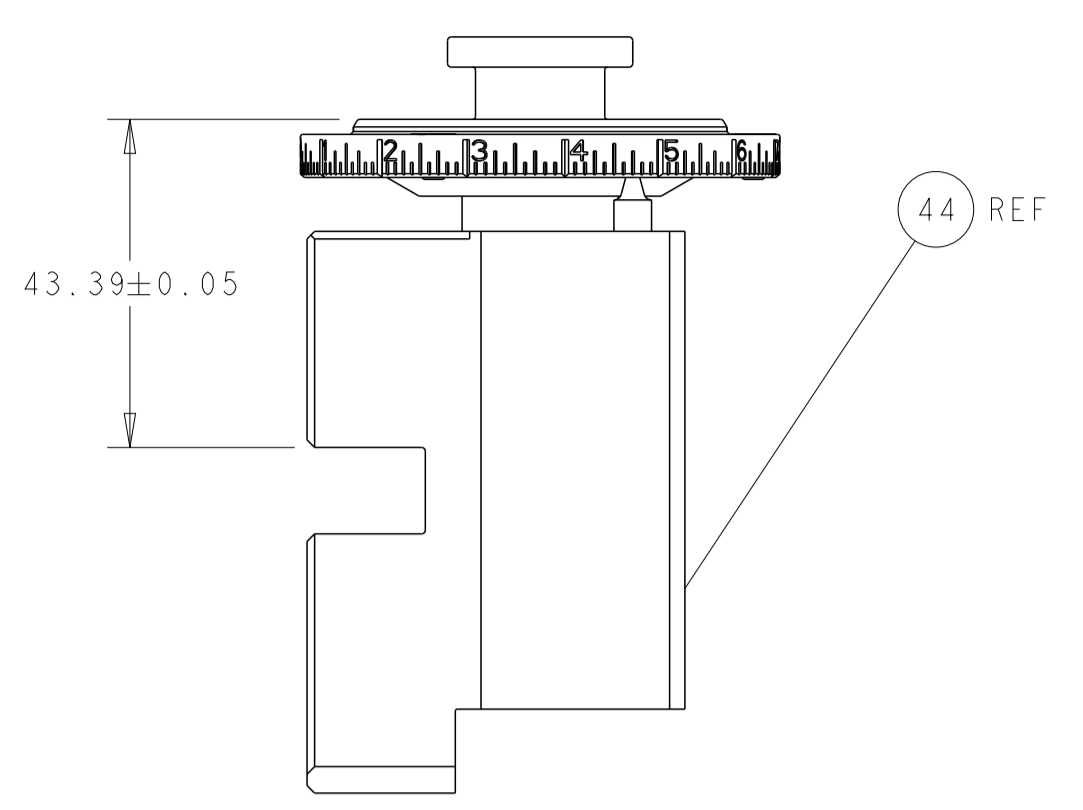

RAM SET-UP

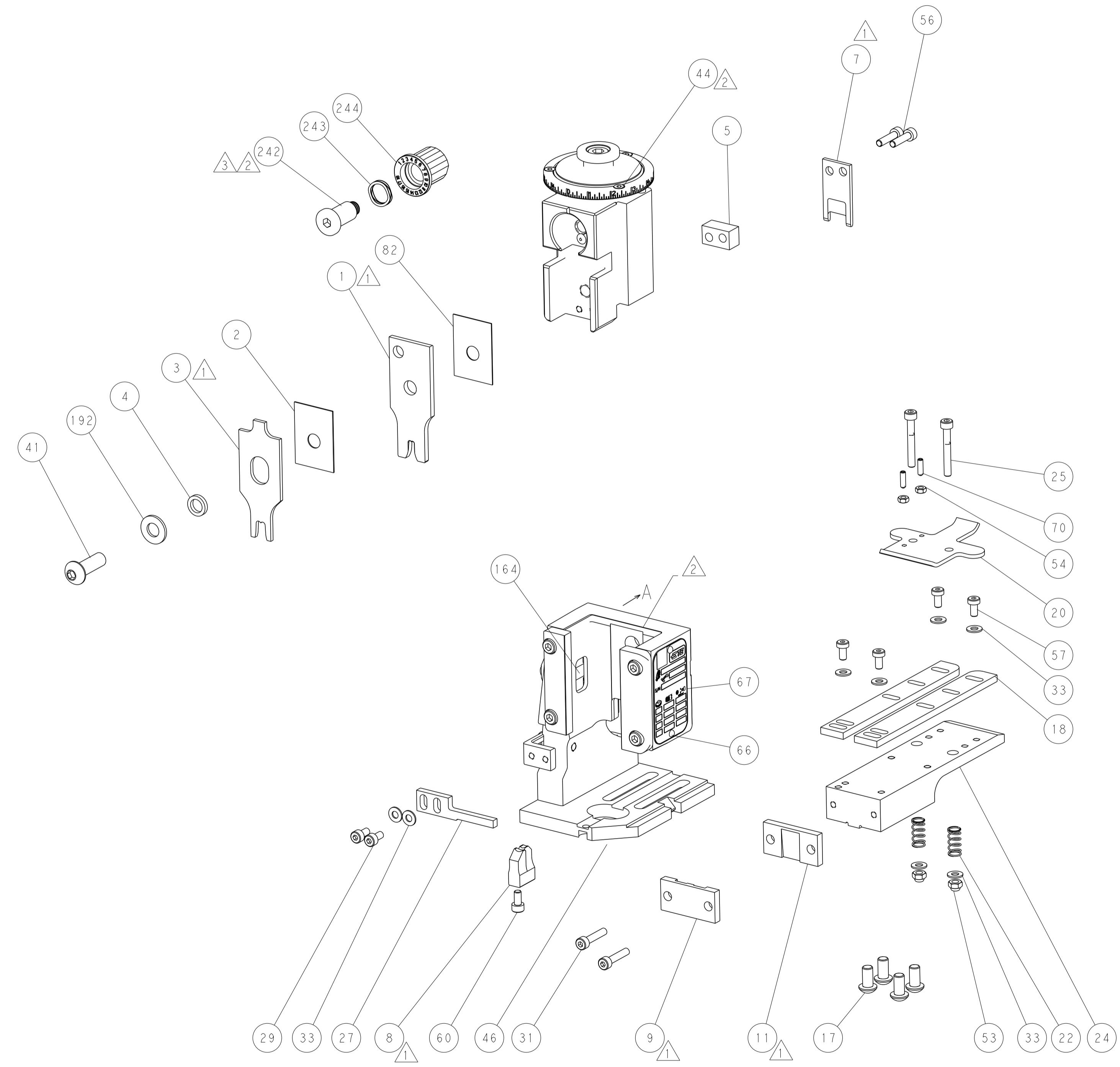

FEED TYPE

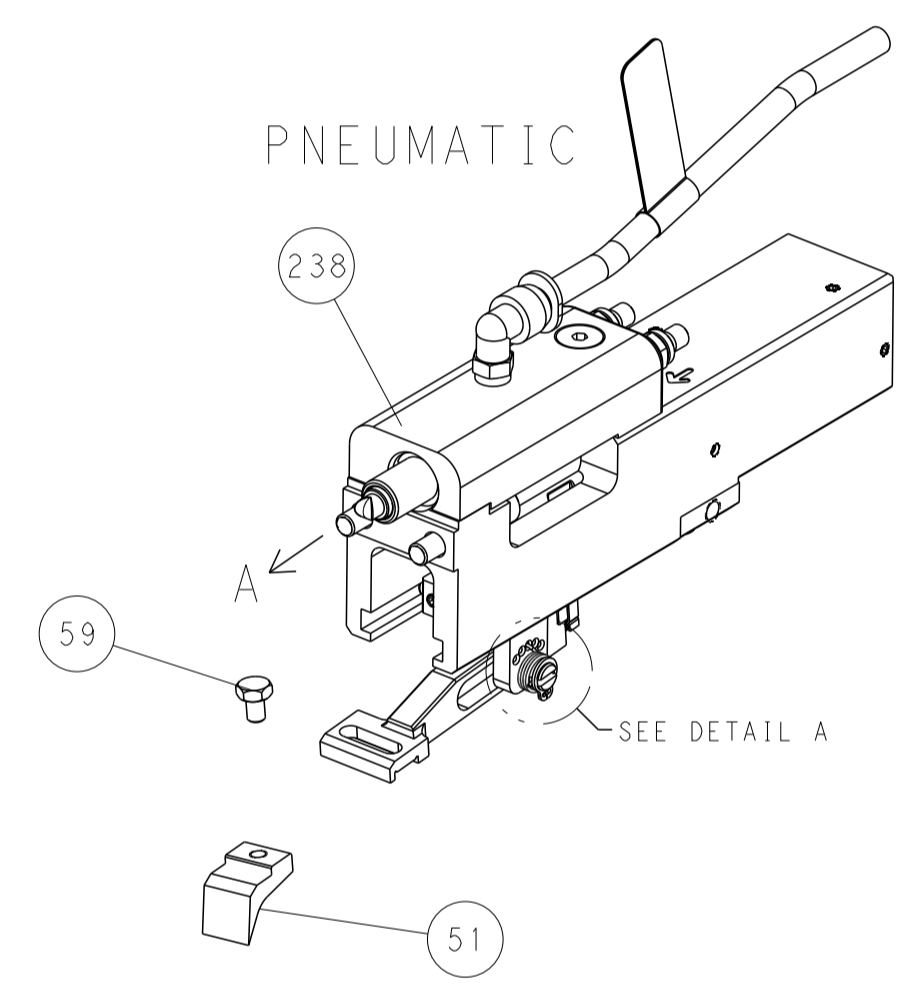

FEED SPRING SETTING POSITION

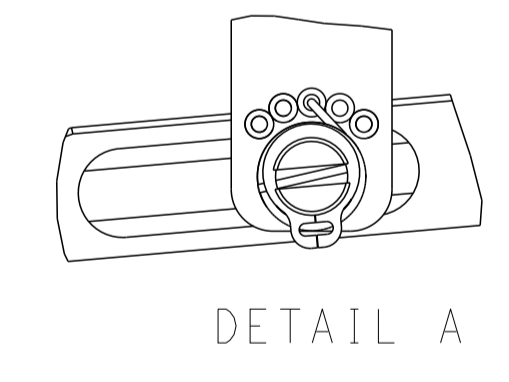

CAM POSITION

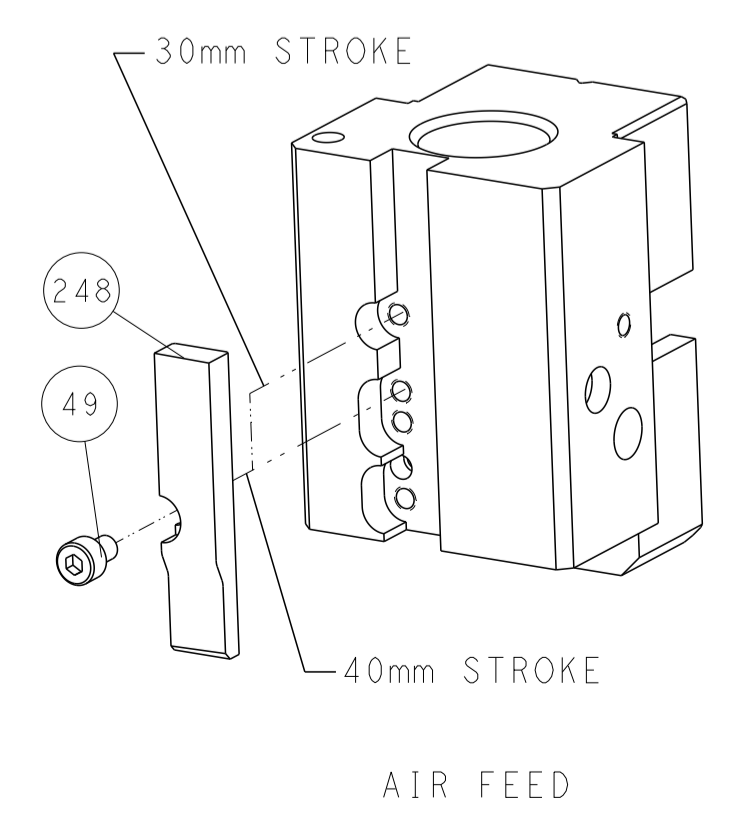

AIR FEED

ATLANTIC VERSION
 Shown on sheets 1 of 4 & 2 of 4
 (Pacific version shown on sheets 3 of 4 & 4 of 4)

<small>THIS DRAWING IS UNPUBLISHED. RELEASED FOR PUBLICATION BY TYCO ELECTRONICS CORPORATION. ALL RIGHTS RESERVED.</small>		DWN: HOFFNER 10JUNE2015 CHK: T.ELBIN 11JUNE2015 APVD: T.ELBIN 11JUNE2015	TE Connectivity Harrisburg, PA 17105-3608
DIMENSIONS: mm 		TOLERANCES UNLESS OTHERWISE SPECIFIED: 0 PLC ± 1 PLC ± 2 PLC ± 3 PLC ± 4 PLC ± ANGLES ± FINISH ±	NAME: Ocean End Feed Applicator SIZE: A1 CAGE CODE: 00779 DRAWING NO: C=2150582 RESTRICTED TO:
MATERIAL:		WEIGHT:	SCALE: 1:1 SHEET: 2 of 4 REV: D

PART NUMBER	REVISION	DESCRIPTION	FEED TYPE
2-2150582-2	D	FINE CRIMP HEIGHT ADJUST	PNEUMATIC
7-2150582-7	A	CRIMP TOOLING KIT	-

PACIFIC VERSION TERMINATOR
 INTERFACE ADAPTER

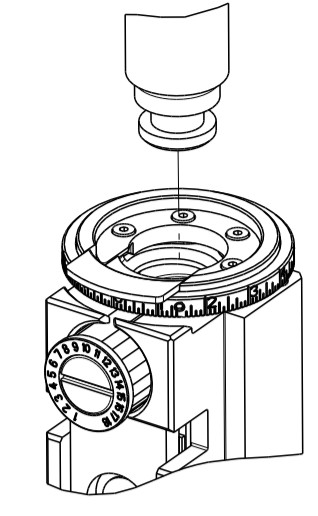

APPLICATOR DATA		
CRIMP	SIZE	TYPE
WIRE	3.81 mm [.150]	F
INSUL	6.35 mm [.250]	F
APPL INSTRUCTIONS 408-35043		

TERMINAL DATA: TE TERMINAL		TE CRIMP SPECIFICATION	
TERMINAL NAME: 250 SERIES AUTOMOTIVE POSITIVE LOCK RECEP.			
WIRE STRIP LENGTH 4.20-5.20 mm [.165-.205 IN]	INSULATION DIAMETER RANGE Ø3.60-5.00 mm [.142-.197 IN]		
TERMINAL APPLICATION SPECIFICATION	114-5060		
TERMINALS APPLIED			
TE TERMINAL	TE TERMINAL	TE TERMINAL	TE TERMINAL
170456-1	170456-2		

WIRE SIZE	CRIMP HEIGHT mm [INCH]	CRIMP HEIGHT REFERENCE SETTING
10 AWG	2.62 +/- 0.05 [.103 +/- .002]	5.9
5.00mm ²	2.62 +/- 0.05 [.103 +/- .002]	5.9
12 AWG	2.20 +/- 0.05 [.087 +/- .002]	10.1
3.00mm ²	2.20 +/- 0.05 [.087 +/- .002]	10.1

- RECOMMENDED SPARE PARTS
- REFER TO SUPPLIED INSTRUCTION SHEET FOR CLEANING, LUBRICATION AND STORAGE OF APPLICATOR.
- APPLY PART NUMBER 2-23419-6 LOCTITE TO THREADS OF ITEM 242.
- CRIMP HEIGHT REFERENCE SETTING WAS THE SETTING USED WHEN THE APPLICATOR WAS QUALIFIED AT THE FACTORY. ADJUSTMENT MAY BE NECESSARY WHEN RUNNING APPLICATOR IN THE FIELD.
- TERMINAL PITCH NOT COMPATIBLE WITH MECHANICAL FEED.
- UNLESS SPECIFIED OTHERWISE TORQUE VALUES SHALL BE USED PER DOCUMENT, 101-35000.

***WARNING**
 ON INSTALLATION, SET WIRE DISC TO CRIMP HEIGHT REFERENCE SETTING FOR LARGEST WIRE SIZE. CRIMP HEIGHT REFERENCE SETTINGS GREATER THAN THE VALUE SHOWN MAY CAUSE DAMAGE TO THE CRIMP TOOLING. REFER TO THE INSTRUCTION SHEET FOR PROPER SETUP AND ADJUSTMENTS.

LOC	DIST	REVISIONS					
A	66	P	LTN	DESCRIPTION	DATE	OWN	APVD
-	-	-	-	SEE SHEET 1	-	-	-

-	1	2119082-3	CAM, SNAIL, INSULATION ADJUSTMENT	244
-	1	2079764-1	WASHER, WAVE SPRING, CREST-TO-CREST	243
-	1	2119083-1	RETAINER, INSULATION DIAL	242
-	1	2844940-4	AIR FEED MODULE	238
-	1	1-18028-0	WASHER, FLAT, REG M8	192
-	4	2079383-9	SCR, BHSC, RoHS (M6 X 20)	186
-	REF	994970-2	COUNTER, MAGNETIC	164
-	1	2119641-2	FEED CAM, AIR FEED	152
-	1	2168083-8	SCR, SKT HD CAP, RoHS, M4 X 16	144
-	1	2119655-6	APPLICATOR BASIC ASSEMBLY, EF	141
-	1	1803518-1	RAM ASSEMBLY, EF PACIFIC	140
-	1	455888-4	SPACER, CRIMPER	82
-	1	1803607-4	DOCUMENTATION PACKAGE	71
-	2	2-18032-2	SCR, SET, FLT PNT, M3 X 10.0	70
-	1	2119740-1	TAG, IDENTIFICATION	67
-	2	2168078-1	SCREW, DRIVE, RH, RoHS, 2 x .188	66
-	1	5-18022-5	SCR, HEX HD CAP, M4 X 6.0	59
-	4	2168400-4	SHCS, LOW HEAD, RoHS, M4 X 8	57
-	2	2168083-8	SCR, SKT HD CAP, RoHS, M4 X 16	56
-	2	5018030-1	NUT, HEX, REG, RoHS, M3	54
-	2	986965-8	NUT, LOCK, HEX, TORQUE (M4)	53
-	1	2063961-1	FEED FINGER	51
-	1	18023-9	SCR, SKT HD CAP M4 X 6.0	49
-	1	1803602-1	SCR, BHSC, RoHS (M8 X 25)	41
-	8	1-18028-2	WASHER, FLAT, REG M4	33
-	2	2168083-9	SCR, SKT HD CAP, RoHS, M4 X 20	31
-	2	2168083-2	SCR, SKT HD CAP, RoHS, M4 X 8.0	29
-	1	690455-1	STRIPPER, FRONT CASTING	27
-	2	1-2168083-5	SCR, SKT HD CAP, RoHS, M4 X 30	25
-	1	1752371-5	PLATE, STRIP GUIDE	24
-	2	22281-9	SPRING, COMPRESSION	22
-	1	1803292-4	DRAG	20
-	2	1901259-7	GUIDE, LOWER STRIP	18
-	1	240644-1	PLATE, REAR SHEAR	11
-	-	-	-	10
-	1	690482-4	PLATE, FRONT SHEAR	9
-	1	1-1803074-4	ANVIL, COMBINATION, END FEED	8
-	1	1-2217206-0	BLADE, SLUG	7
-	-	-	-	6
-	1	5-240641-5	SPACER	5
-	1	1-238011-0	BLOCK, CRIMPER SPACER	4
-	1	6-1803016-6	CRIMPER, INSULATION F	3
-	1	455888-5	SPACER, CRIMPER	2
-	1	3-1633609-8	CRIMPER, WIRE	1
-	77-22	PART NO	DESCRIPTION	ITEM NO

PACIFIC VERSION
 Shown on sheets 3 of 4 & 4 of 4
 (Atlantic version shown on sheets 1 of 4 & 2 of 4)

DIMENSIONS: mm 		TOLERANCES UNLESS OTHERWISE SPECIFIED: 0 PLC ± 1 PLC ± 2 PLC ± 3 PLC ± 4 PLC ± ANGLES ± FINISH ±		DWN: HOFFNER 10 JUNE 2015 CHK: T. ELBIN 11 JUNE 2015 APVD: T. ELBIN 11 JUNE 2015		NAME: TE Connectivity Harrisburg, PA 17105-3608	
MATERIAL:		APPLICATION SPEC:		SIZE: A1 CAGE CODE: 00779 DRAWING NO: ©=2150582		RESTRICTED TO:	
WEIGHT:		SCALE: 1:1		SHEET: 3 OF 4		REV: D	

LOC		DIST		REVISIONS			
A	66	P	LTM	DESCRIPTION	DATE	OWN	APVD
		-		SEE SHEET 1			

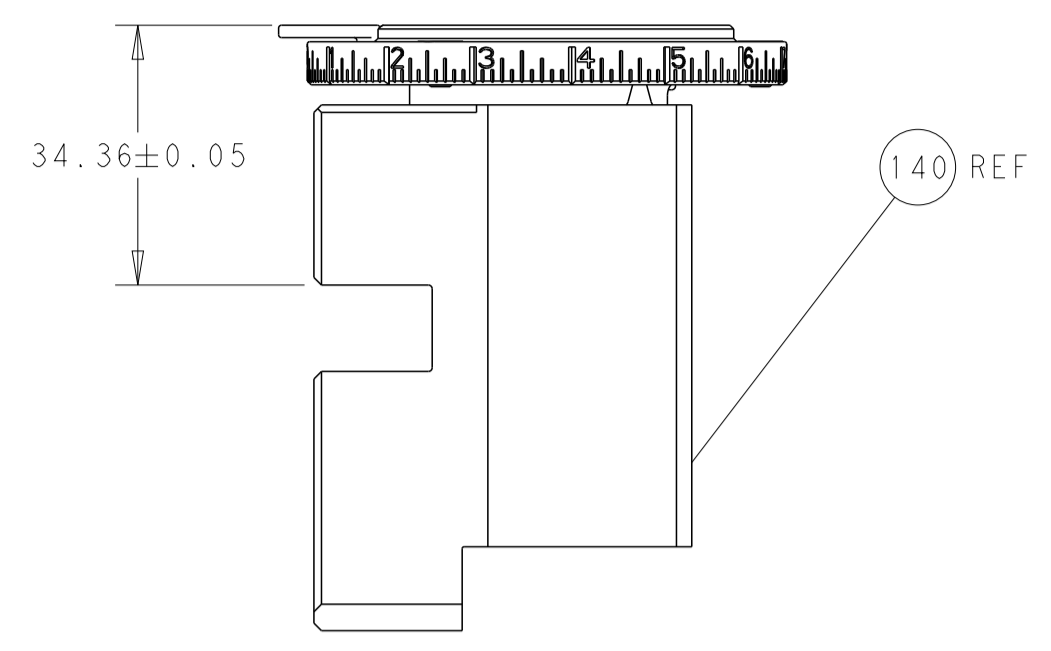

RAM SET-UP

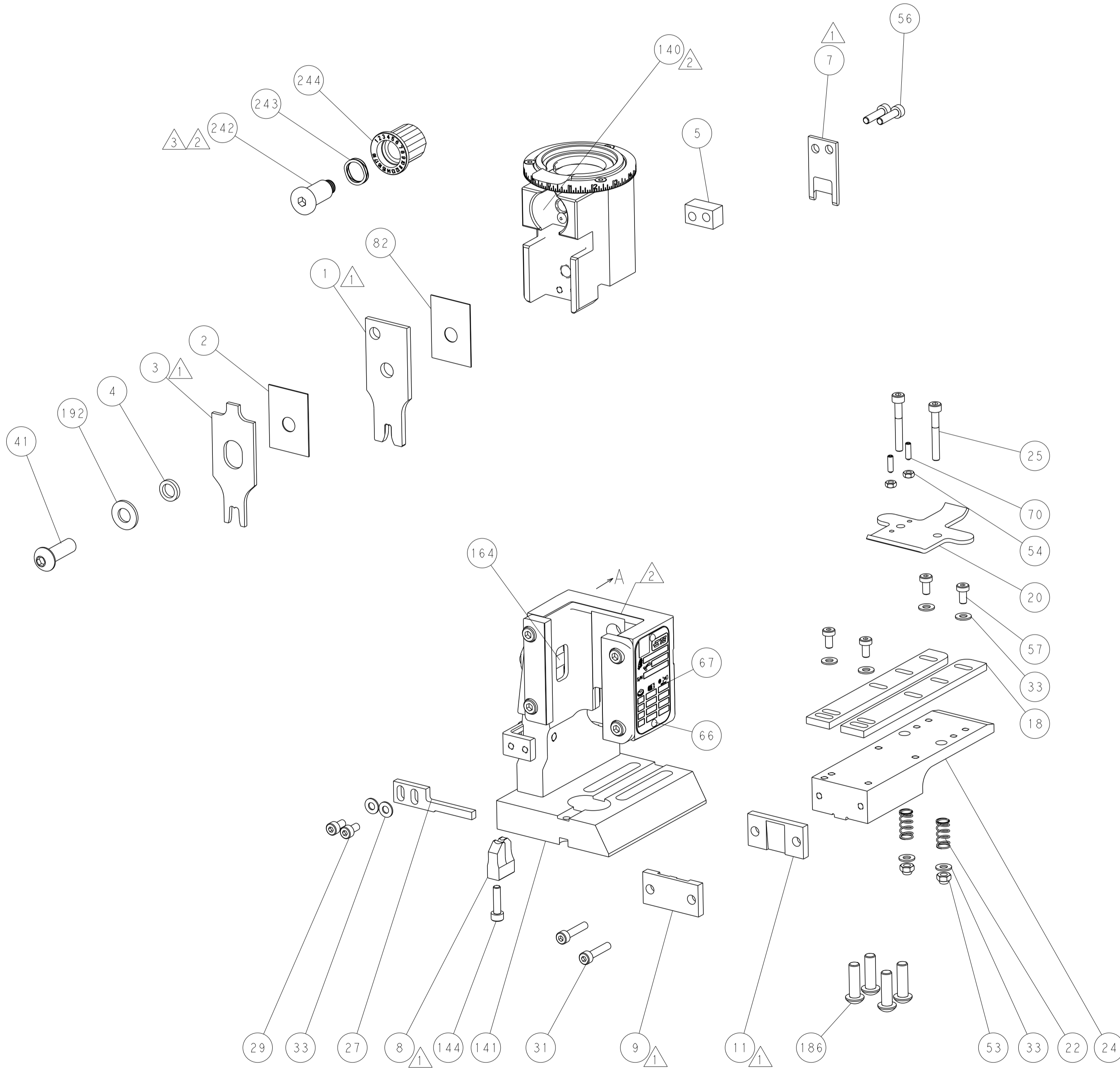

FEED TYPE

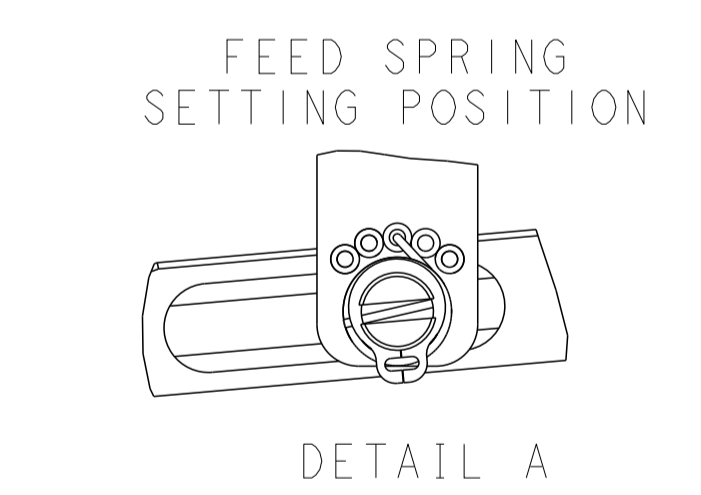
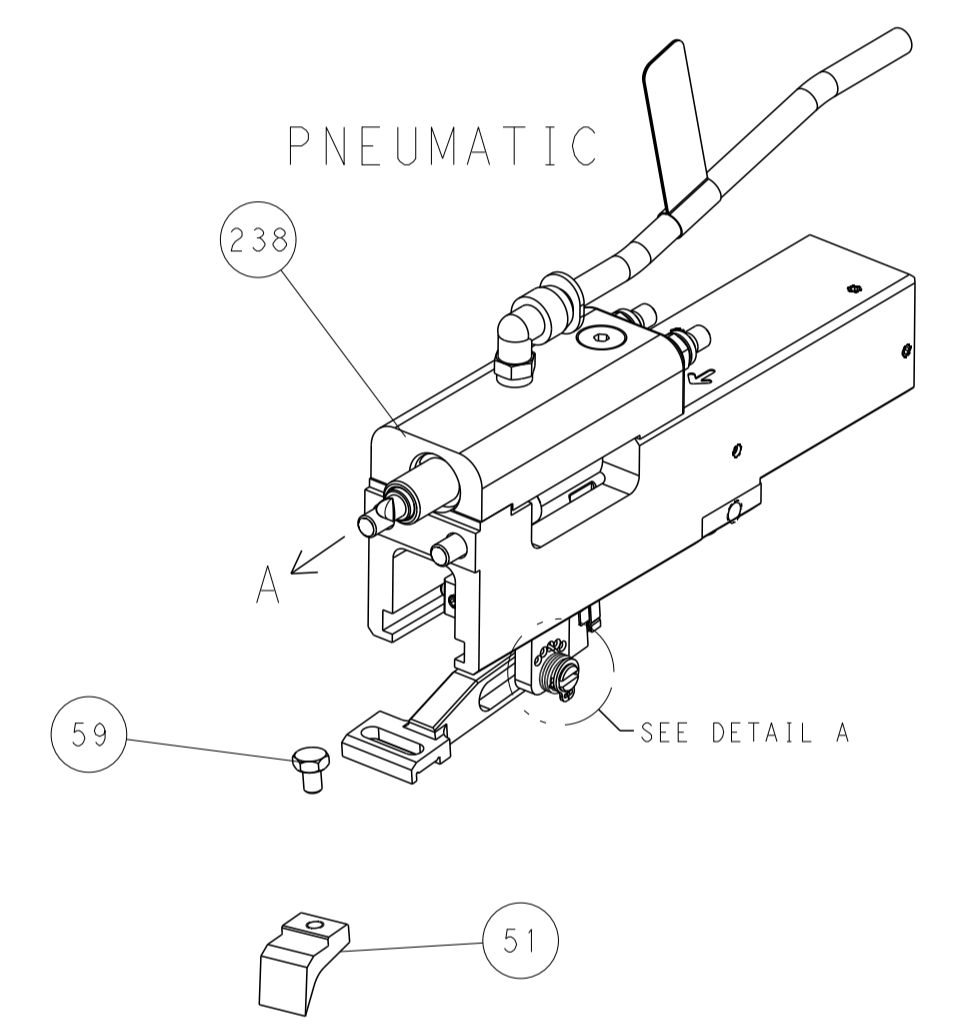

CAM POSITION

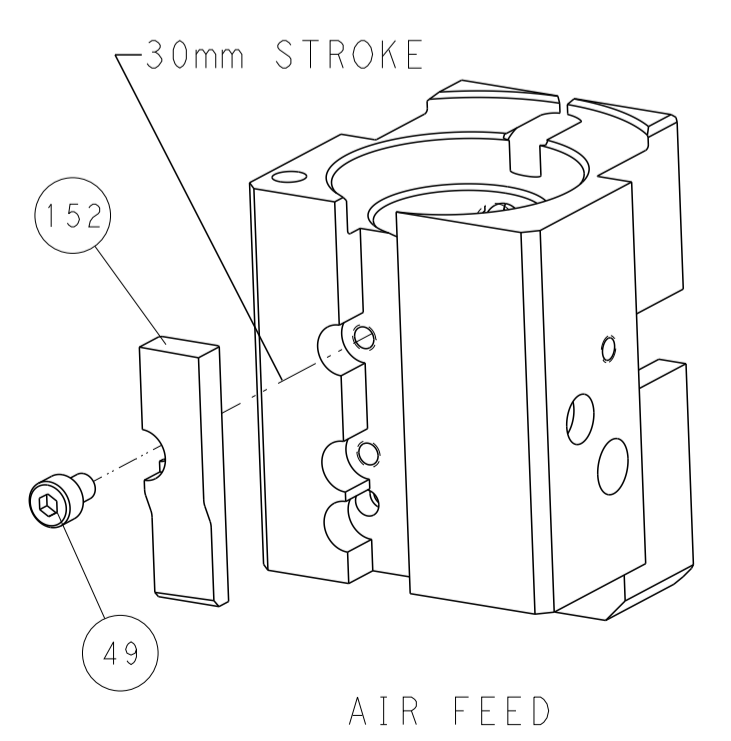

PACIFIC VERSION
 Shown on sheets 3 of 4 & 4 of 4
 (Atlantic version shown on sheets 1 of 4 & 2 of 4)

DIMENSIONS:		TOLERANCES UNLESS OTHERWISE SPECIFIED:		OWN: HOFFNER 10JUNE2015		TE Connectivity	
mm		0 PLC ±		CHK: T. ELBIN 11JUNE2015		Harrisburg, PA 17105-3608	
Ø		1 PLC ±		APVD: T. ELBIN 11JUNE2015		NAME: Ocean End Feed Applicator	
H		2 PLC ±		PRODUCT SPEC		SIZE: CAGE CODE: DRAWING NO:	
D		3 PLC ±		APPLICATION SPEC		RESTRICTED TO:	
R		4 PLC ±		WEIGHT		A 00779 C=2150582	
ANGLES		FINISH		Customer Accessible Production Drawing		SCALE: 1:1 SHEET 4 OF 4 REV D	