

Development Kit

MLX91206

REV004 – February 2013

1 Description

The development kit provides the needed information and components to develop a current sensor based on the MLX91206. The main goal is to show the functionalities and the features of the part in a simple and effective way.

The kit includes:

- 1 sample MLX91206-CAH-001
- 1 sample MLX91206-CAH-002
- 1 sample MLX91206-CAH-003
- 1 sample MLX91206-CAL-001
- 1 sample MLX91206-CAL-002
- 1 sample MLX91206-CAL-003
- 1 separate PCB_EC01
- 1 separate PCB_EC02
- 1 separate PCB_EC03
- 3 shields U_12

The kit does not include a bus bar.

Datasheet and Application Note can be found on www.melexis.com

2 Specification of EC-01

The included PCB utilizes PCB traces for medium current range measurements.

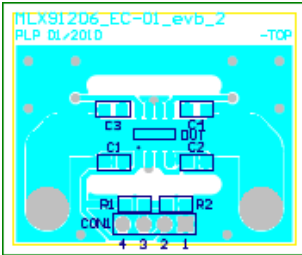
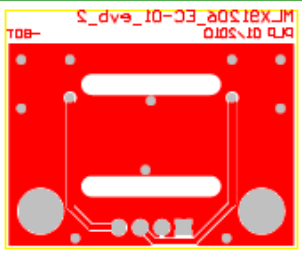
Layer:	Two layer with copper thickness 105µm The top layer is a conductor The bottom layer is an expanded ground layer	
	TOP- layer	Bottom- layer
		
Current:	We recommend ⁽¹⁾ : MAX 30A RMS for PCB application	
Dimension [l/b/h]:	36.8mm x 30.5mm x 1.6mm	

(1): The maximum current is limited by the PCB. For higher currents (> 30A), one can use an external conductor (i.e. a bus bar).

3 Specification of EC-02

The included PCB is based on PCB loops for small current range measurements.

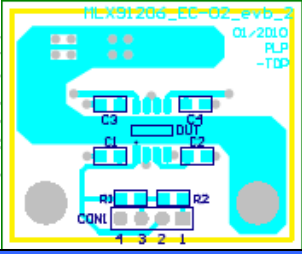
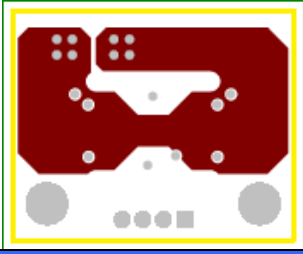
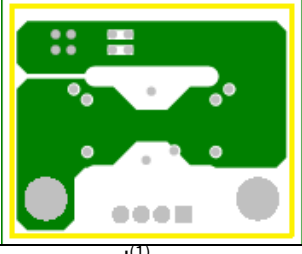
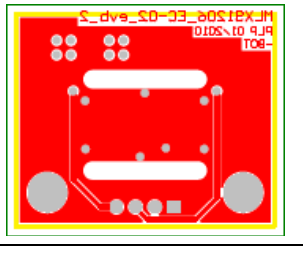
Layer:	Four layers, Top- and Bottom- layer with copper thickness 105µm, Second- and the Third- layer with copper thickness 35µm Three loops are on the PCB	
	Top- layer	Second- layer
		
	Third - layer	Bottom- layer
		
Current:	We recommend ⁽¹⁾ : MAX 30A RMS for PCB application	
Dimension [l/b/h]:	36.8mm x 30.5mm x 2mm	

(1): The maximum current is limited by the PCB. For higher currents (> 30A), one can use an external conductor (i.e. a bus bar).

4 Specification of EC-03

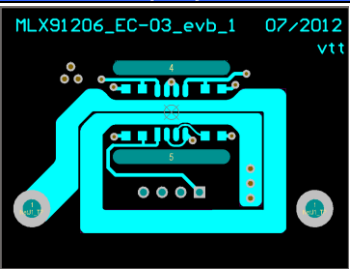
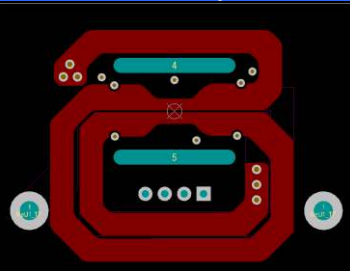
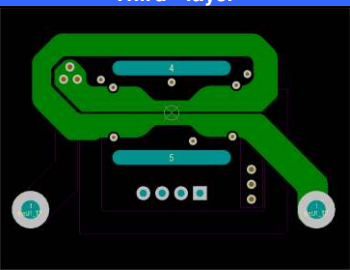
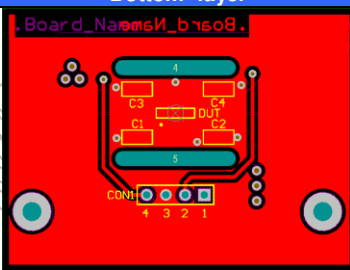
Layer:	Four layers, with copper thickness 105µm, Three loops are on the PCB	
	Top- layer	Second- layer
		
	Third - layer	Bottom- layer
		
Current:	We recommend ⁽¹⁾ : MAX 7A RMS for PCB application	
Dimension [l/b/h]:	42mm x 35mm x 1.5mm	

(1): The maximum current is limited by the PCB. For higher currents (> 10A), one can use EC-01, EC-02 or an external conductor (i.e. a bus bar).

5 Details about the “multi-turn” concept

The purpose of the EC-02 and EC-03 PCBs is to offer a “coil-like” design, which acts as 3 windings (or 6 in the EC-03 case), in order to increase the sensitivity of the sensor. The PCB consists in 3 layers: top, second and third. This design allows the current flowing 3 times (6 times with the EC-03) below the sensor, increasing the field (and the sensitivity) as with a coil.

6 Sensor sensitivity

Product Code	Ordering Option Code	Sensitivity Range (Typ.)
MLX91206	CAL-001	460-700mV/mT (580mV/mT)
MLX91206	CAL-002	300-470mV/mT (380mV/mT)
MLX91206	CAL-003	200-310mV/mT (250mV/mT)
MLX91206	CAH-001	210-330mV/mT (270mV/mT)
MLX91206	CAH-002	130-220mV/mT (170mV/mT)
MLX91206	CAH-003	80-140mV/mT (110mV/mT)
MLX91206	CAH-004	60-110mV/mT (77.5mV/mT)

7 Schematic

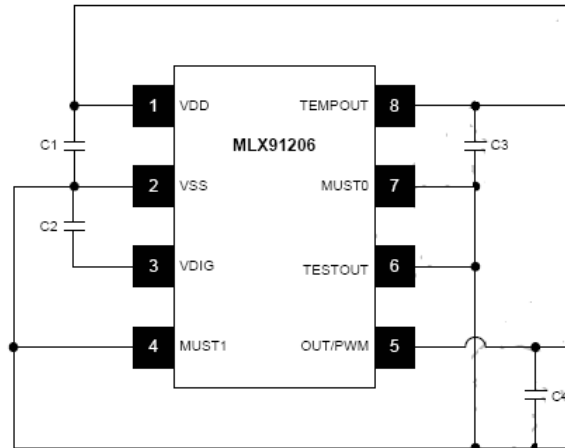

DUT:	MLX91206
C1	100 nF
C2	100 nF
C3	10 nF
C4	10 nF

VDD:	pos. supply voltage
VSS:	supply common
OUT/PWM:	analog sensor output
TEMPOUT:	temperature output

CON1 on the PCB EC-01 and EC-02:

Pin #	Connected to
1	GND/VSS
2	VDD
3	OUT/PWM
4	TEMPOUT

CON1 on the PCB EC-03:

Pin #	Connected to
1	VDD
2	OUT/PWM
3	GND/VSS
4	TEMPOUT

8 U_12 shield description

The shield is made of soft ferromagnetic material (i.e. low cost Fe-Si or Ni-Fe alloys) with a high μ value, this attracts and concentrates the magnetic flux. In order to get a low hysteresis the shields are annealed after shaping. Any applied mechanical stress will deteriorate the performance and should be avoided. The purpose of the shield is to concentrate the wanted signal and to reduce the influence of stray fields. Our shield is usable for both bus bar and PCB applications.

8.1 Geometry

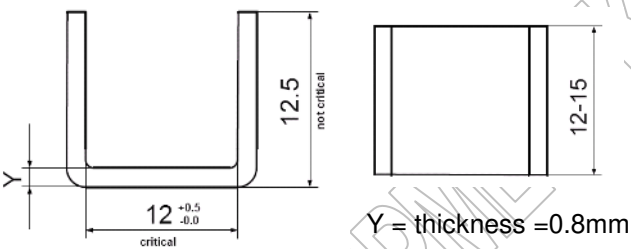
View	Dimension [mm]
	 <p>Y = thickness = 0.8mm</p>

- Material: Mu - Metal with 48%Ni
- Shielding factor is > 50 in the linear range
- Nonlinearity is < 0.05mT in the linear range
- The onset of the saturation starts at about ± 25 mT
- Weight: 3.14g

8.2 Good to know about shield

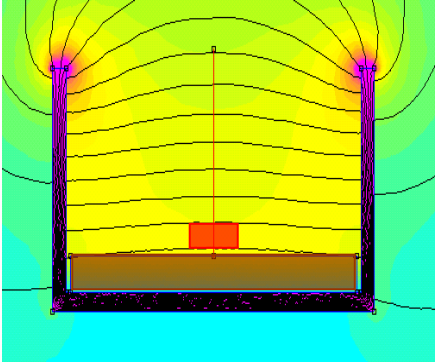
Simulation	Recommendation
	<ul style="list-style-type: none"> • The closer the sensor to the ground plate of the shield, the better the shielding against external stray fields → try to position the sensor as close as possible to the ground plate of the shield • The higher and longer the shield the better the shielding → choose the right dimension for your application • The closer the sensor to the bus bar the better is the signal to noise ratio → try to position the sensor as close as possible to the bus bar

9 Typical output

9.1 Typical output with PCB_EC-01

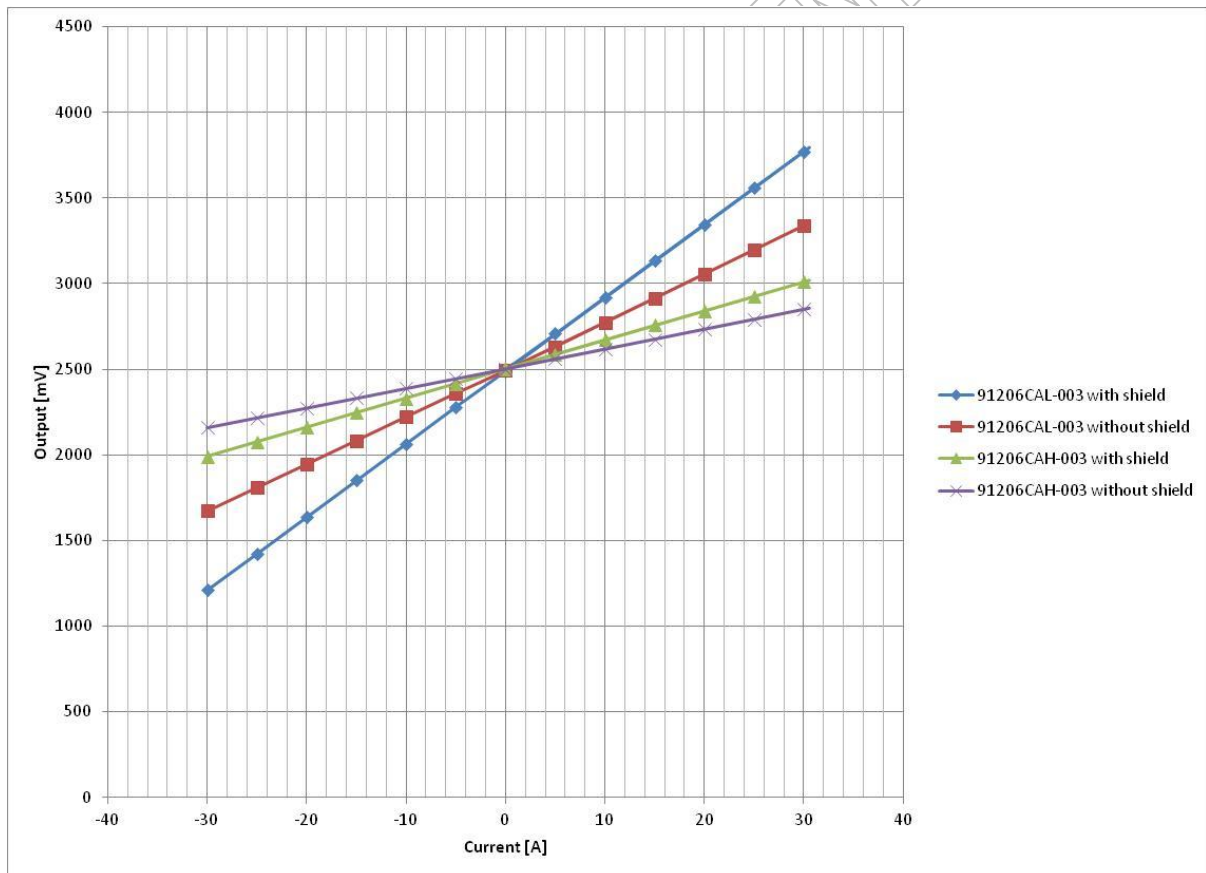
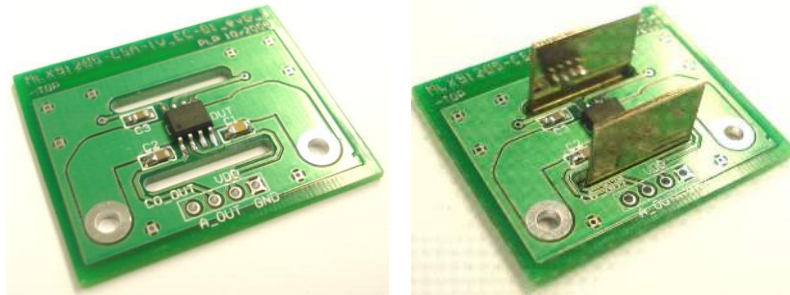

	without shield		with shield	
	91206CAH-003	91206CAL-003	91206CAH-003	91206CAL-003
Sensitivity [mV/A]:	12.7	28	18.7	42.5
Current range [A]:	+/-200	+/-70	+/-135	+/-50

9.2 Typical output with PCB_EC-02

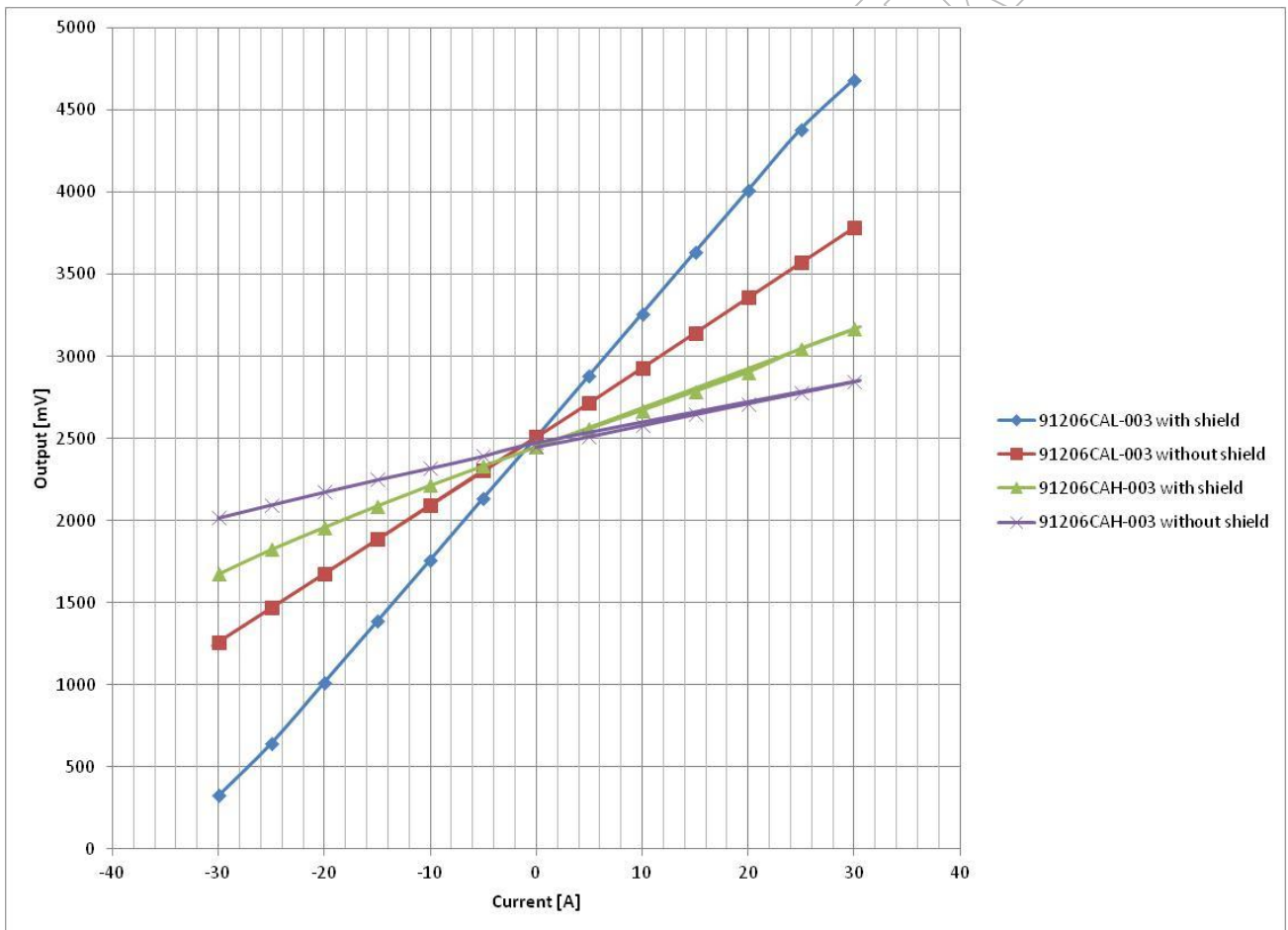
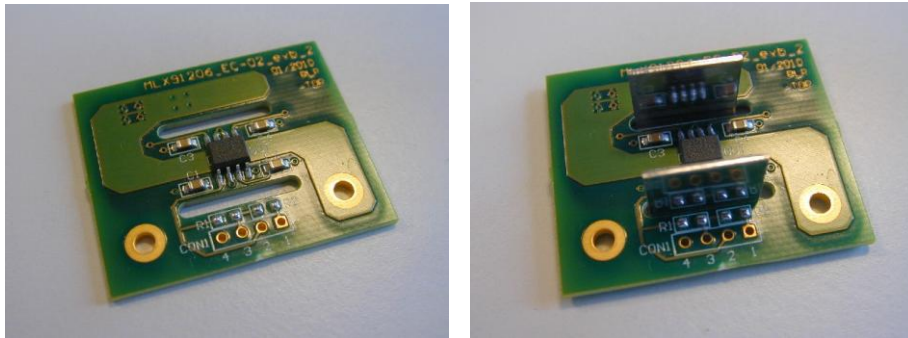

	without shield		with shield	
	91206CAH-003	91206CAL-003	91206CAH-003	91206CAL-003
Sensitivity [mV/A]:	27.5	62	40.7	92.5
Current range [A]:	+/-90	+/-30	+/-50	+/-18

9.3 Typical output with PCB_EC-03

9.3.1 Without shield

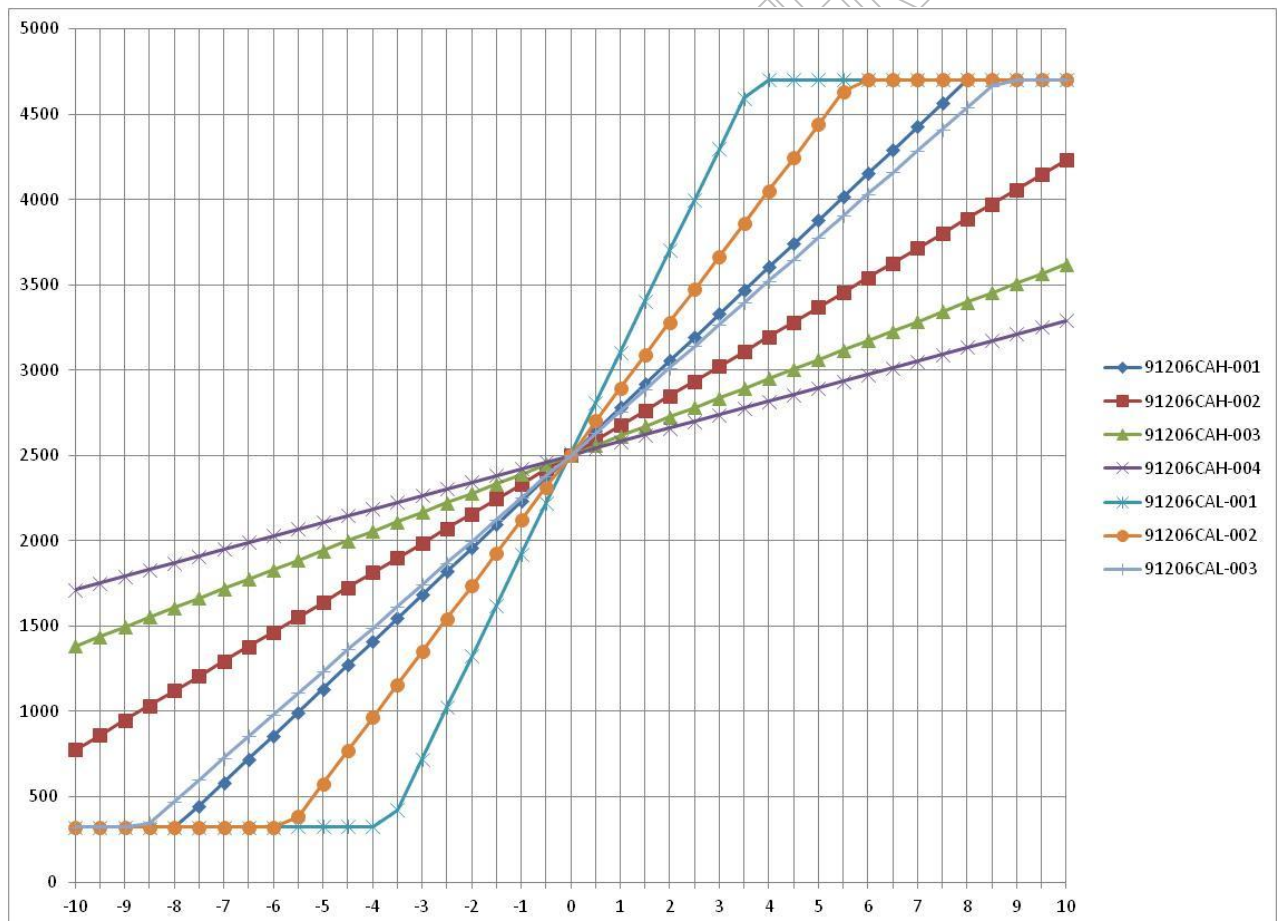
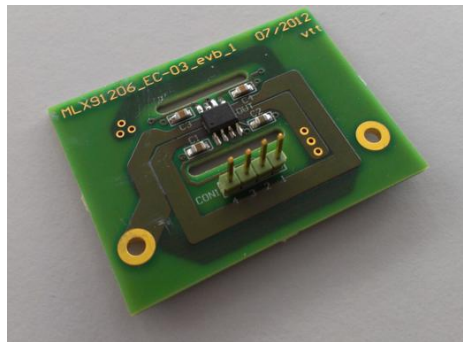

	CAH-001	CAH-002	CAH-003	CAH-004	CAL-001	CAL-002	CAL-003
Sensitivity [mV/A]:	275	170	111	78	595	385	254
Current range [A]:	+/-7	+/-12	+/-18	+/-25	+/-3	+/-5	+/-8

The different sensors are factory programmed. Please refer to the datasheet for more details about sensitivity ranges.

9.3.2 With shield (U_12 and UC_12 shields)

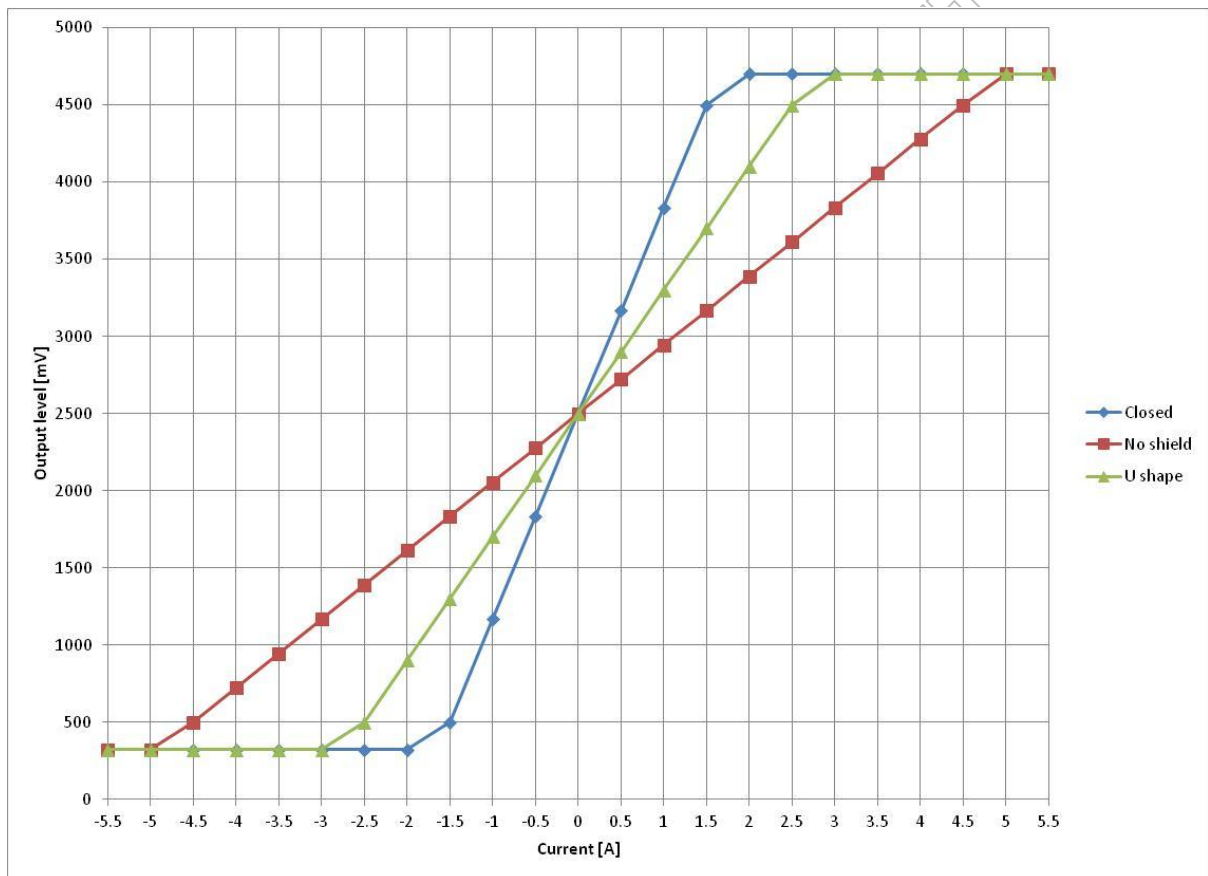
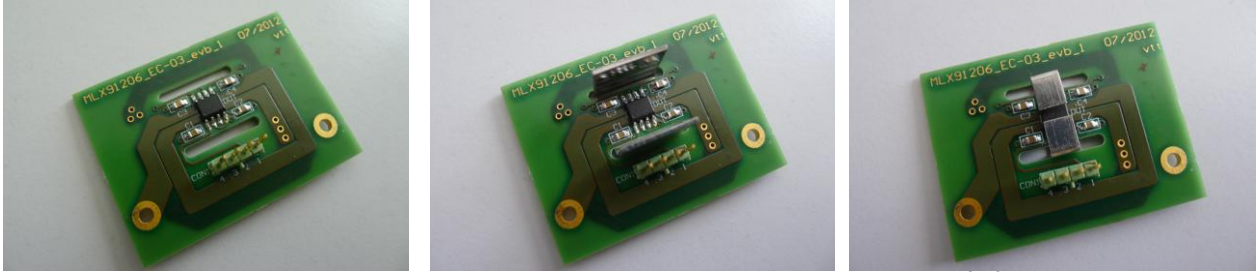

These results are obtained with:

- The PCB EC-03
- The MLX91206CAL-001 calibrated for maximum sensitivity

	CAL-001 Without shield	CAL-001 With U_12 shield	CAL-001 With UC_12 shield
Sensitivity [mV/A]:	444	800	1333
Current range [A]:	+/-5	+/-2.5	+/-1.5

The UC_12 shield is available on request.

9.4 Typical output with bus bar

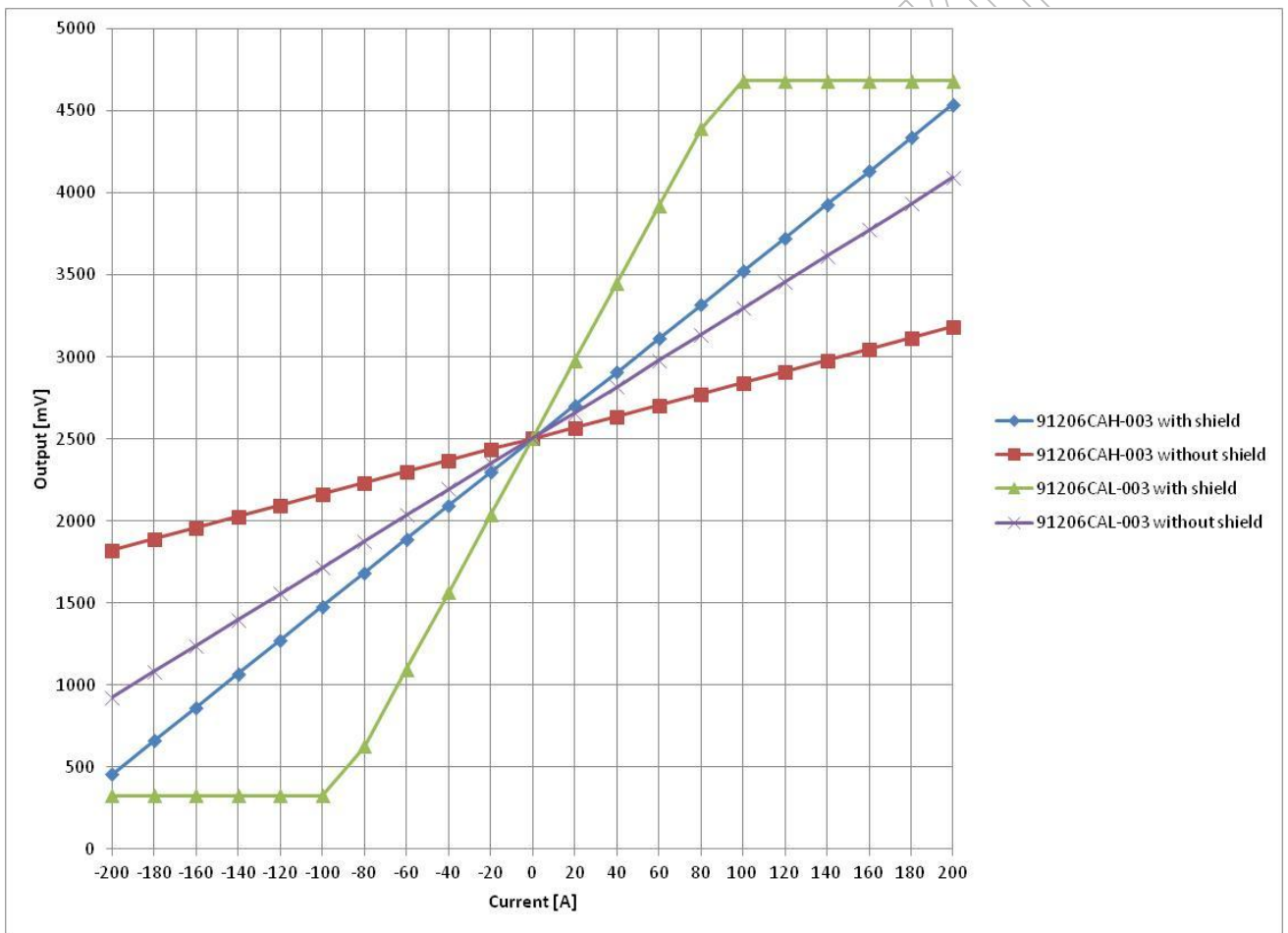
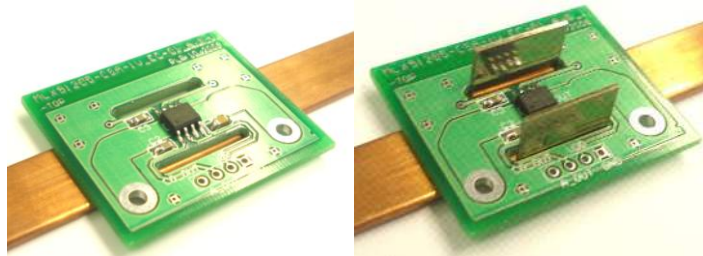

	without shield		with shield	
	91206CAH-003	91206CAL-003	91206CAH-003	91206CAL-003
Sensitivity [mV/A]:	3.6	8	12.2	24
Current range [A]:	+/-555	+/-250	+/-160	+/-80

- The dimension of the used copper bus bar was 12mm x 100mm x 2mm.

10 Possible programming

10.1 OFFSET vs. XA parameter

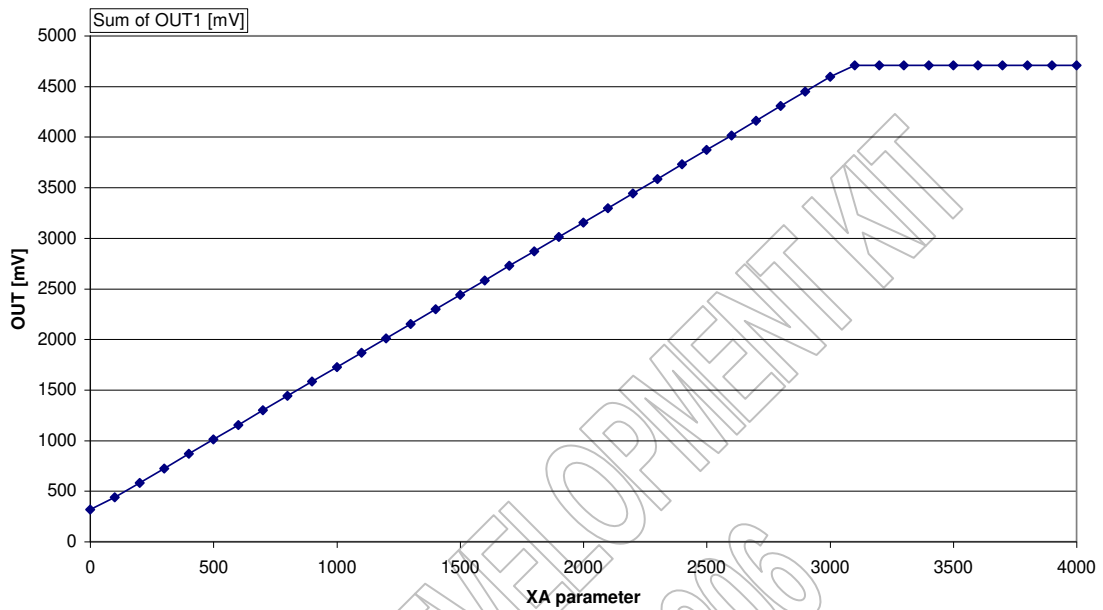

- Possible to set the offset voltage between 300 and 4700 mV

10.2 OUT vs. CURRENT with different ROUGHGAIN and FINEGAIN

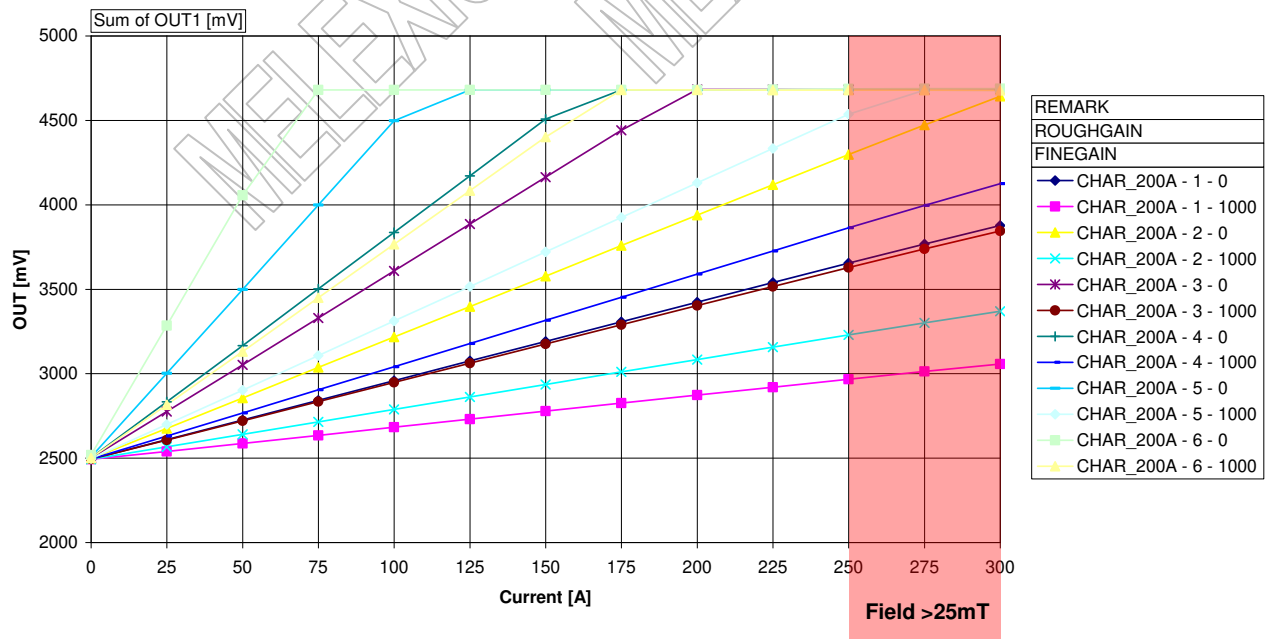

- Measurements based on bus bar 12mm x 100mm x 2mm
- Demonstrators can be build for ranges from $\pm 50A$ to $\pm 250A$

10.3 Sensitivity vs. ROUGHGAIN with different FINEGAIN

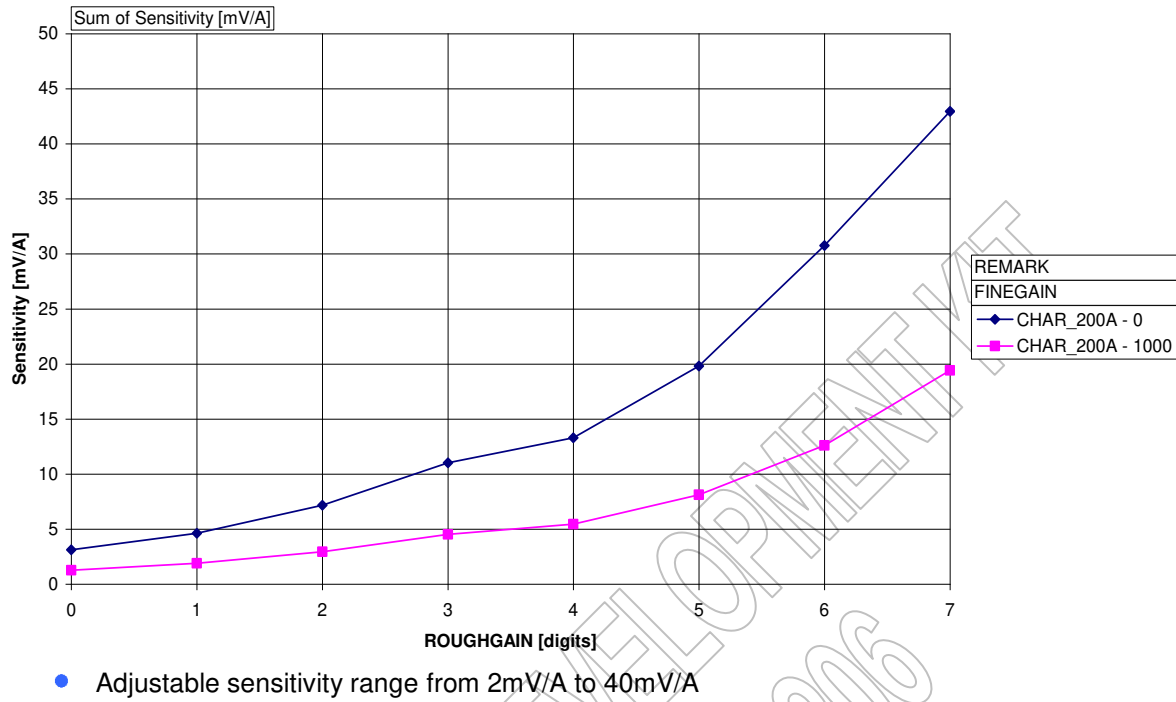

Examples of possible demonstrators with MLX91206:

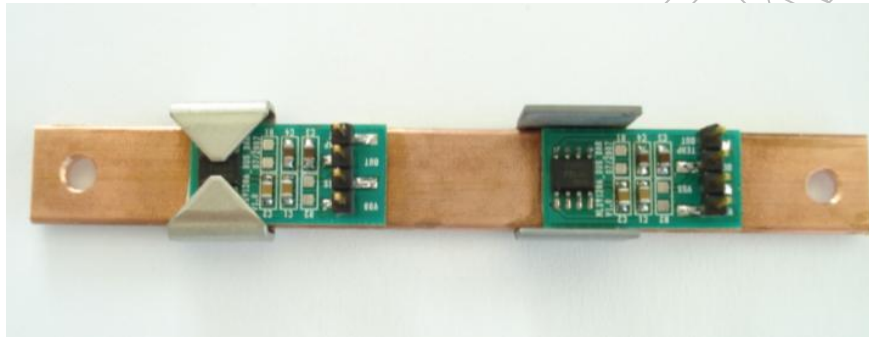
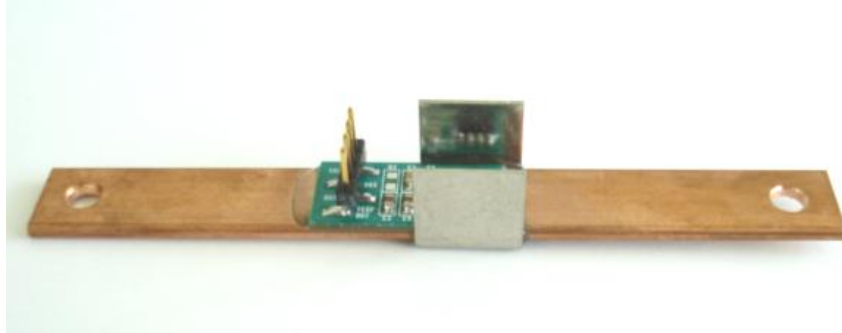

Melexis will be happy to support you design-in. Please feel free to contact us for further questions.

Sebastien Grisot
Application Engineer
sgt@melexis.com