

P	LTR	DESCRIPTION	DATE	DWN	APVD
	A2	NOTE ON OIL RESIDUE ADDED	09DEC2010	PKS	MP
	A3	REVISED PER ECR-19-017980	09DEC2021	SS	EW

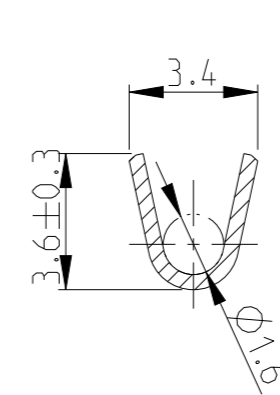

SECTION B-B  
SCALE 5:1

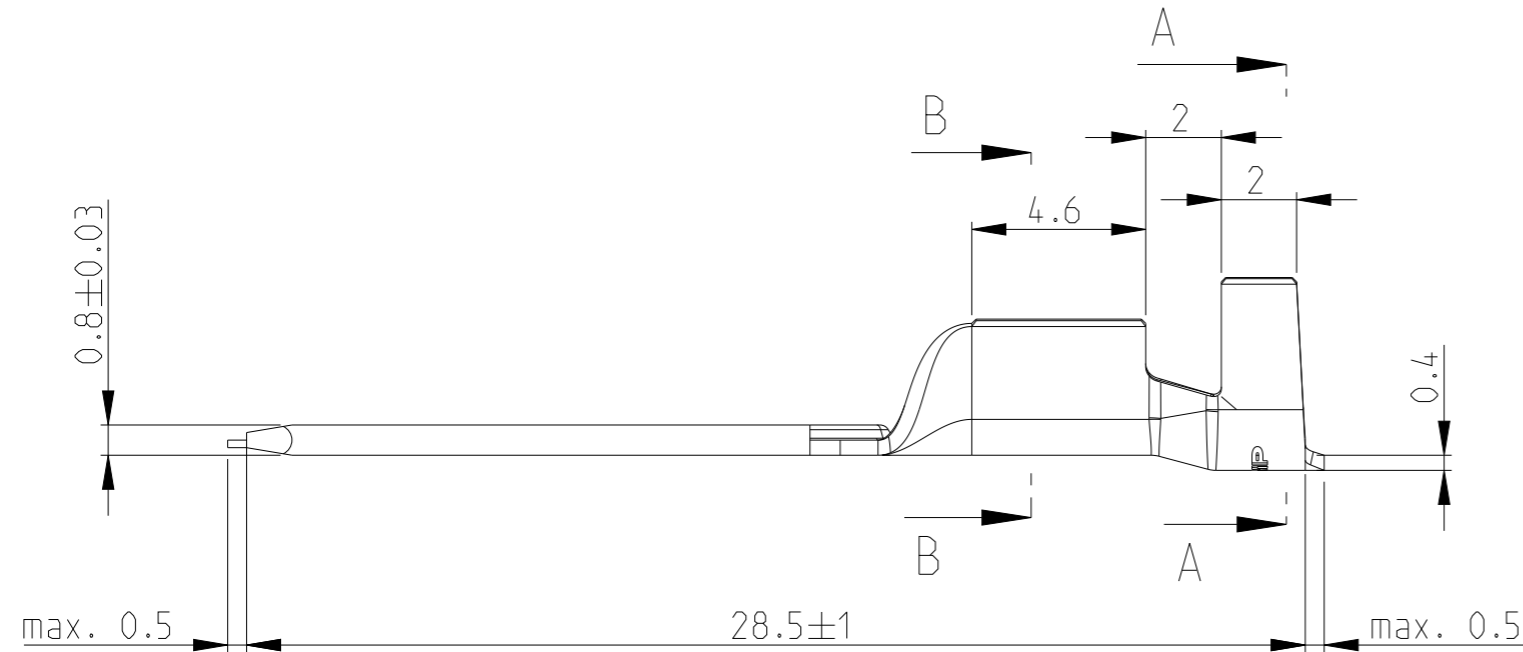
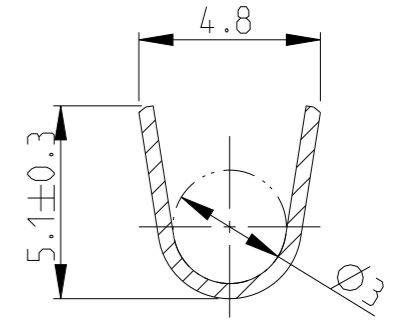

SECTION A-A  
SCALE 5:1

- Kontakt geeignet fuer:
  - Lackdraht  $\varnothing$  0.9...1.6mm (auch bei Verwendung von Backlackdraht)
  - Isolation  $\varnothing$  2.5...3.5mm
- SLOT ACCEPTS:
  - MAGNET WIRE 0.9...1.6mm DIA (THE SAME BY ENAMELED WIRE )
  - ISOLATION 2.5...3.5mm DIA

SPLICE FREE VERSION

4. NO VISIBLE OIL RESIDUES

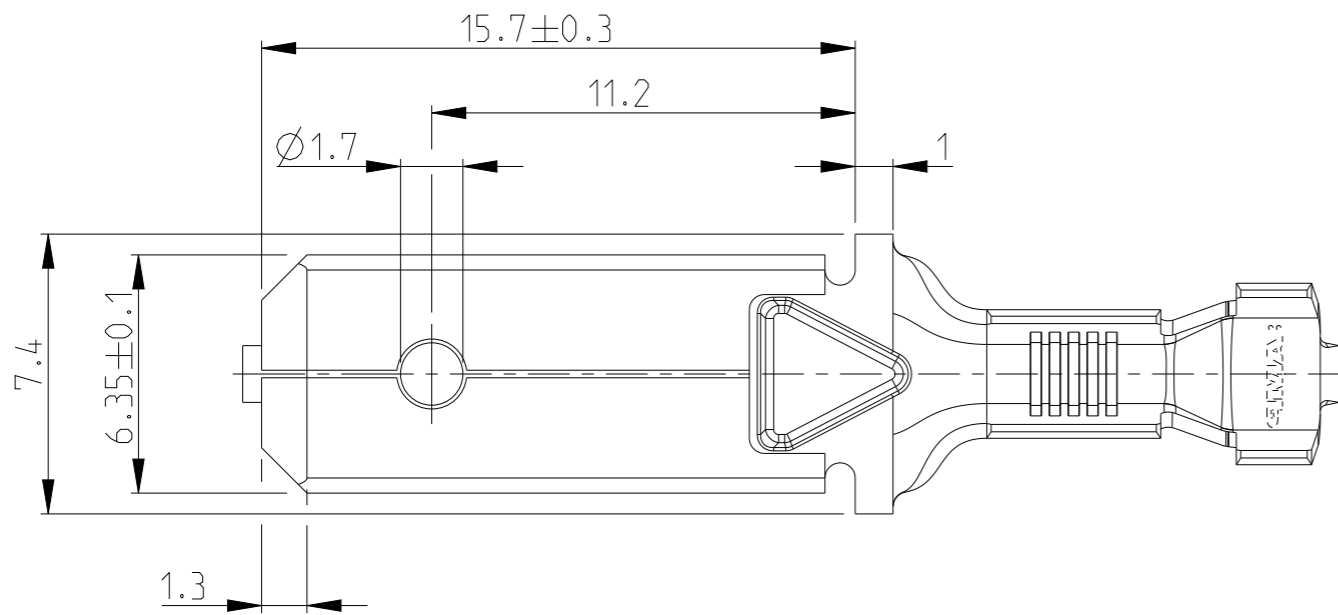

OBSOLETE		BLANK	1-928890-1
		BLANK	928890-1
	NOTE	FINISH	PART NO

THIS DRAWING IS A CONTROLLED DOCUMENT.		DWN Goerke 25SEP1989	TE Connectivity	
		CHK Ploesser 26SEP1989		
DIMENSIONS: mm	TOLERANCES UNLESS OTHERWISE SPECIFIED:	APVD -	NAME FASTON TAB, SIZE 6.3 (AMPLIVAR) WITH INSULATION SUPPORT	
	0 PLC $\pm$ 1 PLC $\pm$ 2 PLC $\pm$ 3 PLC $\pm$ 4 PLC $\pm$ ANGLES $\pm 1^\circ$	PRODUCT SPEC -	SIZE A3	
MATERIAL -	FINISH -	APPLICATION SPEC -	CAGE CODE 00779	DRAWING NO G-928890
		WEIGHT -	RESTRICTED TO -	
		CUSTOMER DRAWING	SCALE 5:1	SHEET 1 OF 1
				REV A3