

THIS DRAWING IS UNPUBLISHED. RELEASED FOR PUBLICATION  
 © COPYRIGHT BY TYCO ELECTRONICS CORPORATION. ALL RIGHTS RESERVED.

LOC	DIST	REVISIONS			
P	LTR	DESCRIPTION	DATE	DWN	APVD
AJ	16	0	RELEASED.	12DEC2005	JGH GM

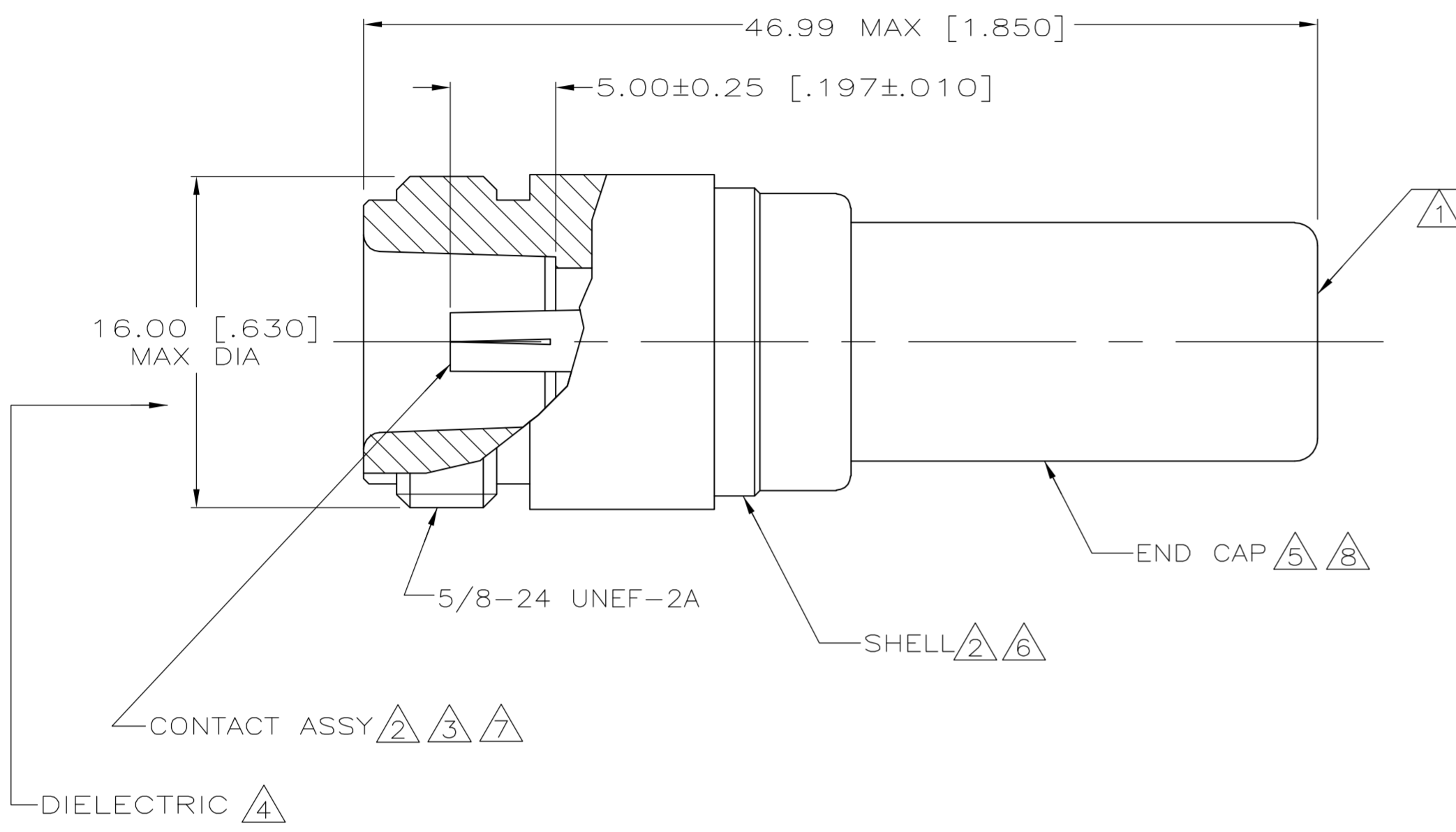

- ① STEEL STAMP "50 Ω, 1W" THIS SURFACE.
- ② BRASS PER ASTM B 16 OR B 36.
- ③ BERYLLIUM COPPER PER ASTM B 196.
- ④ PTFE PER ASTM D 1710.
- ⑤ COPPER PER ASTM B 152.
- ⑥ NICKEL PLATE PER QQ-N-290, 2.54 μm [.000100] MIN THICK.
- ⑦ GOLD PLATE PER ASTM B 488, 2.54 μm [.000100] MIN THICK.
- ⑧ TIN PLATE PER ASTM B 545, 2.54 μm [.000100] MIN THICK.

5227997-1  
 PART NUMBER

THIS DRAWING IS A CONTROLLED DOCUMENT.		DWN J. HAVENER 12DEC2005	Tyco Electronics Corporation Harrisburg, PA 17105-3608																			
DIMENSIONS: mm [INCHES]		CHK G. MICHAEL 12DEC2005																				
TOLERANCES UNLESS OTHERWISE SPECIFIED:		APVD G. MICHAEL 12DEC2005	NAME TERMINATOR, JACK, SERIES N																			
<table border="0"> <tr><td>0 PLC</td><td>±</td><td>-</td></tr> <tr><td>1 PLC</td><td>±</td><td>-</td></tr> <tr><td>2 PLC</td><td>±</td><td>-</td></tr> <tr><td>3 PLC</td><td>±</td><td>-</td></tr> <tr><td>4 PLC</td><td>±</td><td>-</td></tr> <tr><td>ANGLES</td><td>±</td><td>-</td></tr> </table>		0 PLC	±	-	1 PLC	±	-	2 PLC	±	-	3 PLC	±	-	4 PLC	±	-	ANGLES	±	-	PRODUCT SPEC -	APPLICATION SPEC -	RESTRICTED TO -
0 PLC	±	-																				
1 PLC	±	-																				
2 PLC	±	-																				
3 PLC	±	-																				
4 PLC	±	-																				
ANGLES	±	-																				
MATERIAL NOTES 2 THRU 5	FINISH NOTES 6 THRU 8	WEIGHT -	SIZE A2	CAGE CODE 00779																		
CUSTOMER DRAWING		SCALE 4:1	DRAWING NO C=5227997	SHEET 1 of 1																		
				REV 0																		

5227997