

Photologic[®] Slotted Optical Switches

Type OPB916 Series

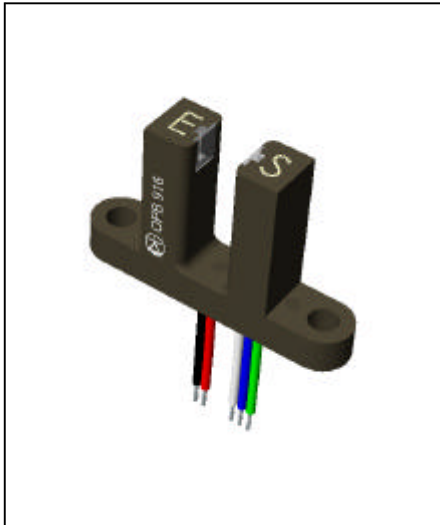

Features

- Choice of output configuration
- 24" min 26 AWG wires
- Low power consumption

Description

The OPB916 consists of an infrared emitting diode and a Photologic[®] photo integrated circuit mounted in an opaque housing with clear windows for dust protection. The deep slot allows for a longer reach of the optical path from the mounting plane, .650" (16.51 mm).

Internal apertures are .010" x 0.06" for the Photologic's "S side" and .050" x 0.06" for the LED, "E side". Two logic states and two electrical output types are available.

Custom electrical, wire or cabling are available. Contact your local representative or Optek for more information.

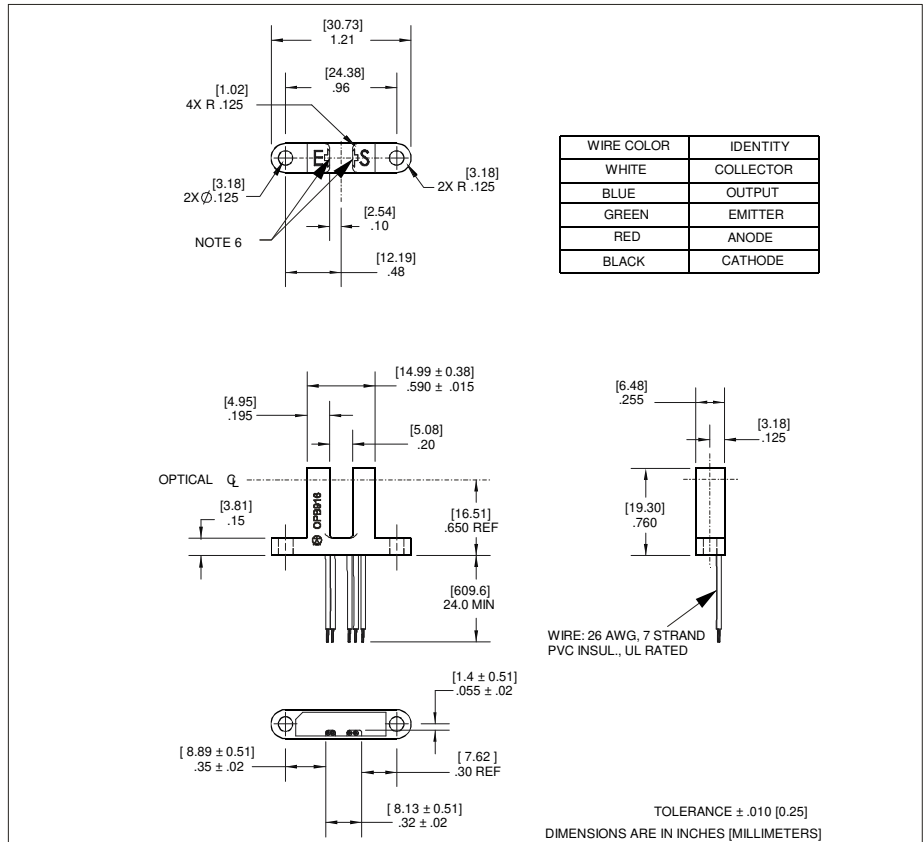

Absolute Maximum Ratings (T_A = 25° C unless otherwise noted)

Supply Voltage V _{CC} (Not to exceed 3 sec.)	18 V
Storage and Operating Temperature Range	-40° C to +80° C
Input Diode Power Dissipation	100 mW ⁽¹⁾
Output Photologic [®] Power Dissipation	90 mW ⁽²⁾
Voltage at Output Lead (Open Collector Output)	35 V
Diode Forward D.C. Current	50 mA
Diode Reverse D.C. Voltage	2 V

NOTES:

- (1) Derate linearly 1.67 mW/° C above 25° C.
- (2) Derate linearly 2.67 mW/° C above 70° C.
- (3) Clear dust protection.
- (4) Normal application would be with light source blocked, simulated by I_F = 0 mA.
- (5) All parameters tested using pulse technique.

PRECAUTIONS: Exposure of the plastic body to chlorinated hydrocarbons and ketones such as thread lock and instant adhesive products will degrade the plastic body. Cleaning agents methanol and isopropanol are recommended. Spray or wipe do not submerge.

Visit our website at www.optekinc.com
 or email us at sensors@optekinc.com



For RoHS compliant devices add "Z" to the end of the part number: OPB916BZ

PART NUMBER GUIDE

OPB916XXX

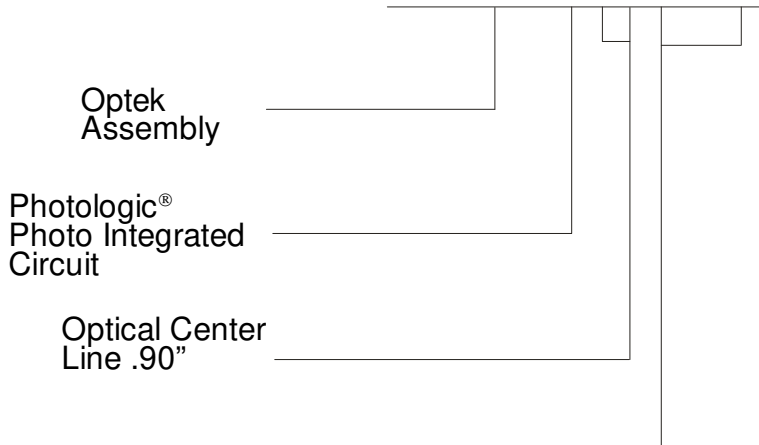

Electrical Specification Variations

B - Buffered with 10K Ω pull-up

BOC - Buffered Open-Collector Output

I - Inverted with 10K Ω pull-up

IOC - Inverted Open-Collector Output

Schematics

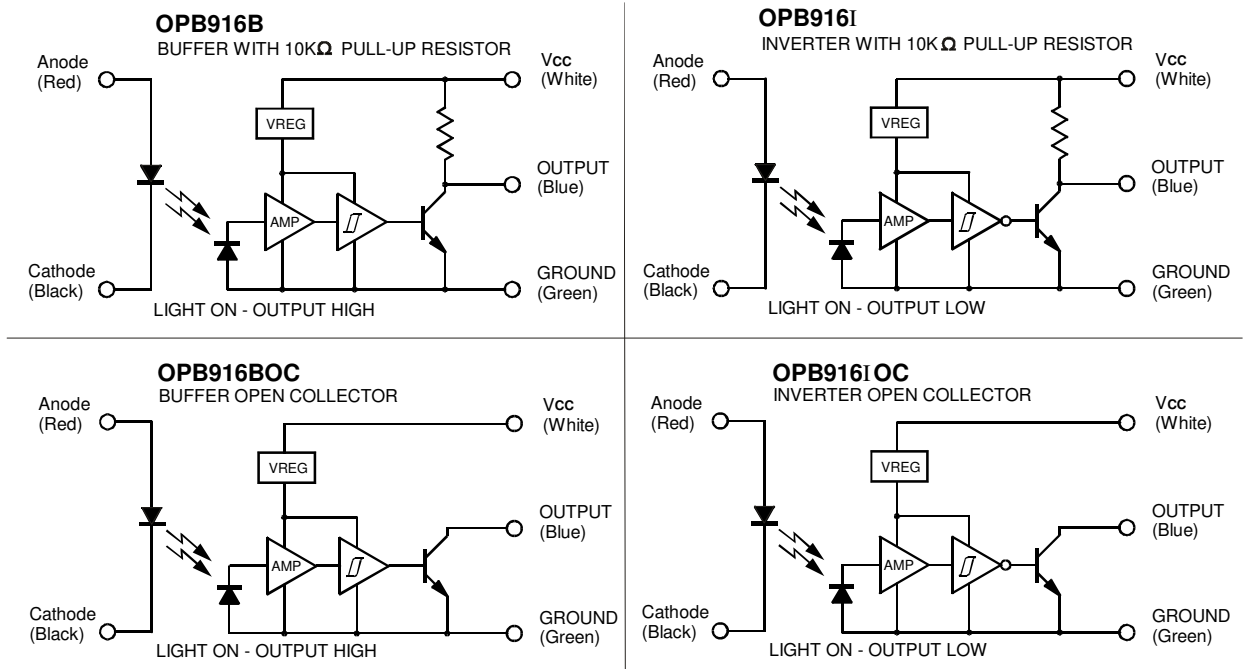

Type OPB916 Series

Electrical Characteristics ($T_A = 25^\circ\text{C}$ unless otherwise noted)

SYMBOL	PARAMETER	MIN	TYP	MAX	UNITS	TEST CONDITIONS
Input Diode						
V_F	Forward Voltage		1.30	1.80	V	$I_F = 20\text{ mA}$
I_R	Reverse Current			100	μA	$V_R = 2\text{ V}$
Phototransistor						
V_{CC}	Operating D.C. Supply Voltage	4.5		16.0	V	
I_{CCL}	Low Level Supply Current: OPB916B and OPB916BOC			7.0	mA	$V_{CC} = 16\text{ V}$, $I_F = 0\text{ mA}^{(4)}$ No Output Load
	OPB916I and OPB916I OC			7.0	mA	$V_{CC} = 16\text{ V}$, $I_F = 10\text{ mA}$ No Output Load
I_{CCH}	High Level Supply Current: OPB916B and OPB916BOC			6.0	mA	$V_{CC} = 16\text{ V}$, $I_F = 10\text{ mA}$ No Output Load
	OPB916I and OPB916I OC			6.0	mA	$V_{CC} = 16\text{ V}$, $I_F = 0\text{ mA}^{(4)}$ No Output Load
V_{OL}	Low Level Output Voltage: OPB916B			0.4	V	$V_{CC} = 4.5\text{ to }16\text{ V}$, $I_F = 0\text{ mA}^{(4)}$ No Output Load
	OPB916BOC			0.4	V	$V_{CC} = 4.5\text{ to }16\text{ V}$, $I_F = 0\text{ mA}^{(4)}$, $I_{OL} = 16\text{ mA}$ No Output Load
	OPB916I			0.4	V	$V_{CC} = 4.5\text{ to }16\text{ V}$, $I_F = 10\text{ mA}$ No Output Load
	OPB916I OC			0.4	V	$V_{CC} = 4.5\text{ to }16\text{ V}$, $I_F = 10\text{ mA}$, $I_{OL} = 16\text{ mA}$ No Output Load
V_{OH}	Low Level Output Voltage: OPB916B	2.4	$V_{CC} - 1.5$		V	$V_{CC} = 4.5\text{ to }16\text{ V}$, $I_F = 10\text{ mA}$ No Output Load
	OPB916I	2.4	$V_{CC} - 1.5$		V	$V_{CC} = 4.5\text{ to }16\text{ V}$, $I_F = 0\text{ mA}^{(4)}$ No Output Load
I_{OH}	High Level Output Current: OPB916BOC		1.0	14	μA	$V_{CC} = 4.5\text{ V}$, $V_{OH} = 30\text{ V}$, $I_F = 10\text{ mA}$
	OPB916I OC		1.0	14	μA	$V_{CC} = 4.5\text{ V}$, $V_{OH} = 30\text{ V}$, $I_F = 0\text{ mA}$
$I_{F(+)}$	LED Positive-Going Threshold Current: OPB916B and OPB916I		5	10	mA	$V_{CC} = 5\text{ V}$ No Output Load
	OPB916BOC and OPB916I OC		5	10	mA	$V_{CC} = 5\text{ V}$, $I_{OL} = 16\text{ mA}$ No Output Load
$I_{F(+)} / I_{F(-)}$	Hysteresis		1.5			
t_r, t_f	Rise Time, Fall Time		50		ns	$V_{CC} = 5\text{ V}$, $I_F = 0\text{ or }10\text{ mA}$
t_{PLH}, t_{PHL}	Propagation Delay Low-High & High-Low		3.0		μs	$R_L = 300\ \Omega\text{ to }5\text{ V}$, $C_L = 50\text{ pF}$

Optek reserves the right to make changes at any time in order to improve design and to supply the best product possible.

Optek Technology, Inc. 1215 W. Crosby Road Carrollton, Texas 75006 (972)323-2200 Fax (972)323-2396